

Designed to provide improved lift assist for Ultrix motors equipped with both a Humminbird® MEGA 360 Imaging™ and MEGA Live Imaging TargetLock™.

Item / Assembly	Part #	Description	Notes	Qty.
2	2298411	GAS SPRING, U1.5	*80/45"	1
	2298415	GAS SPRING, U1.5	*80/52" *112/52"	1
	2298412	GAS SPRING, U1.5	*112/45"	1
A Item 4	2994956	BAG ASM, LIFT ASSIST ACC		1
4	2373434	SCREW-1/4-20 X 3/4 SS PPMS		2

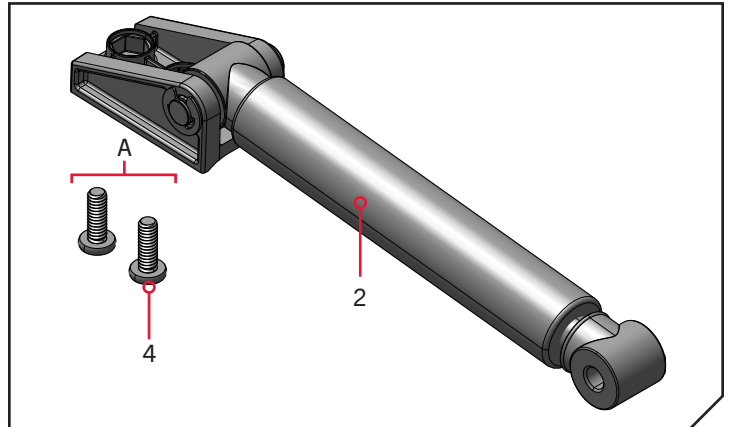

TOOLS AND RESOURCES REQUIRED >

- 1/4" Allen Wrench
- Torque Wrench
- #3 Phillips Screwdriver
- 1/4" Socket Wrench
- A second person to help with the installation
- blue thread locker

MOUNTING CONSIDERATIONS >

The Ultrix Lift Assist Cylinder reduces the effort required for stowing and deploying the trolling motor when both the Humminbird 360 Imaging and MEGA Live Imaging TargetLock accessories are installed. To accomplish the successful installation of the Lift Assist Cylinder, please give consideration to the following:

- Complete the installation of both the Humminbird 360 Imaging and MEGA Live Imaging TargetLock accessories before beginning the installation of the Lift Assist Cylinder. Use the installation instructions provided with the product to complete the installation. Keep the accessories installed to the trolling motor during the installation.
- Ensure that the trolling motor installation is complete. Follow the installation instructions provided with the trolling motor or online at minnkota.johnsonoutdoors.com. The trolling motor installation should be complete before beginning installation on the Lift Assist Cylinder.
- Ensure that the trolling motor is not connected to a power source during the installation to avoid unexpected motor operation.
- During the installation, the load bearing benefits of the Gas Spring and Lift Assist Cylinder are removed. Minn Kota recommends using the help of a second person to hold and secure the Mount during the installation process. Watch for pinch points when working on the installation and do not remove or reinstall the Steering Module until instructed to do so. Use the help of a qualified marine installer if uncomfortable with the installation.
- If using this Lift Assist Cylinder without the use of the Humminbird accessories, Minn Kota recommends installing the original Gas Spring.

⚠ CAUTION

Avoid any unexpected motor operation while performing work on the trolling motor. Disconnect the trolling motor from the battery or power source before beginning any work.

⚠ WARNING

The gas-assist lift mechanism in this unit is under high spring pressure when the motor is in the deployed position. Do not remove the Steering Module assembly from the mount without disconnecting one end of the Gas Spring. Failure to do this can create a condition where accidental pulling of the Pull Grip and Cable may cause the mount to spring open rapidly, striking anyone or anything in the direct path.

> Disconnect the Gas Spring

Disconnect the Gas Spring before removing the Steering Module. The Gas Spring is under high spring pressure. Disconnecting the Gas Spring removes the load-bearing benefits of the Gas Spring. The Gas Spring will be replaced with the new Lift Assist Cylinder when the installation is complete. Ensure that the trolling motor is installed on the Boat Deck before disconnecting the Gas Spring.

1

WARNING

Moving parts can cut or crush. The gas-assist lift mechanism is under pressure. Disconnect the Gas Spring before removing the motor from the mount. Do not engage the Pull Grip and Cable when the motor is removed from the mount until the Gas Spring is disconnected.

- a. In order to remove the Steering Module, the Gas Spring needs to be disconnected. Position the motor so that it is halfway between the stowed and deployed position. Allow the motor to be positioned so that the Lower Unit rests on the Motor Ramp.
- b. To disconnect the Gas Spring, locate the Bracket on the Gas Spring inside the Outer Arm. Two Pan Phillips Machine Screws hold the Bracket for the Gas Spring in place. Using a #3 Phillips Screwdriver, loosen and then remove both screws.
- c. Now it is safe to move the motor into the deployed position to remove the Steering Module.

WARNING

The gas-assist lift mechanism in this unit is under high spring pressure when the motor is in the deployed position. Do not remove the Steering Module assembly from the mount without disconnecting one end of the Gas Spring. Failure to do this can create a condition where accidental pulling of the Pull Grip and Cable may cause the mount to spring open rapidly, striking anyone or anything in the direct path.

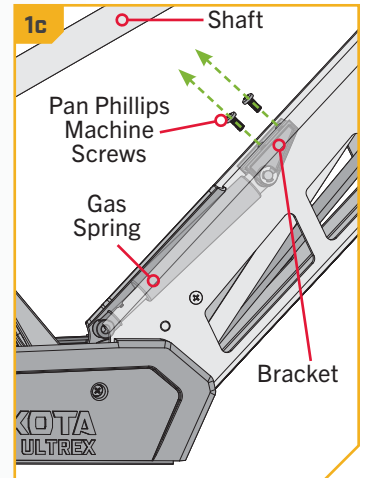
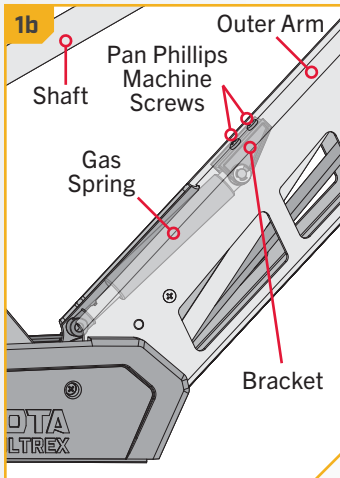
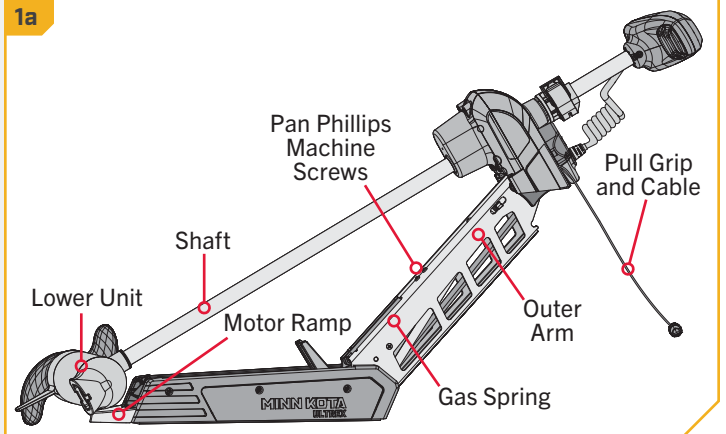

NOTICE: Use a #3 Philips Screwdriver to remove the screws. They have a pre-applied thread locker. Failure to use the recommended tool can cause damage and prevent the screws from being removed.

NOTICE: The Gas Spring can become damaged when moving the Mount, and the damage will prevent the Lift Assist feature from operating correctly. Make sure that the Gas Spring does not get damaged in the Mount.

Remove Steering Module from Mount

Removing the Steering Module removes a large portion of the weight that the Gas Spring displaces. Removal of the Steering Module allows for increased mobility of the Mount to assist in installing the new Lift Assist Cylinder.

1

- a. With the Gas Spring disconnected, place the motor in the deployed position. Carefully lower the trolling motor to the deployed position to avoid damaging the Gas Spring.

WARNING

Moving parts can cut or crush. The gas-assist lift mechanism is under pressure. Disconnect the Gas Spring before removing the motor from the Mount. Do not engage the Pull Grip and Cable until the Gas Spring is disconnected.

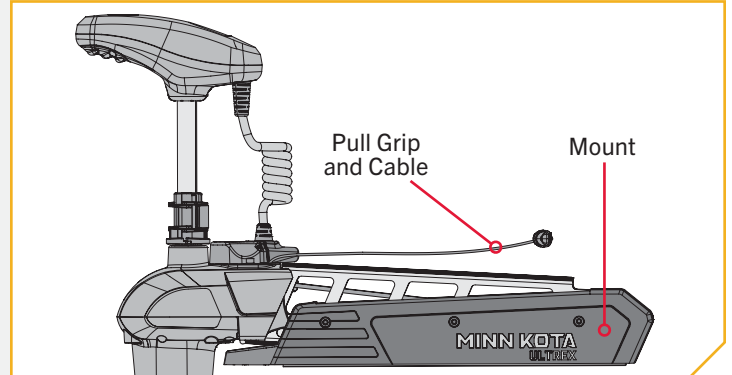

2

- b. Remove the 5/16" Allen Screw with a 1/4" Allen Wrench. The 5/16" Allen Screw is located on the opposite end of the Mount from the hinge that opens and closes when the Mount is stowed and deployed.
- c. Once the Allen Screw and Lock Washer are removed, lift the Steering Module straight up until it is free from the Mount. Set aside for re-installation later in these instructions.

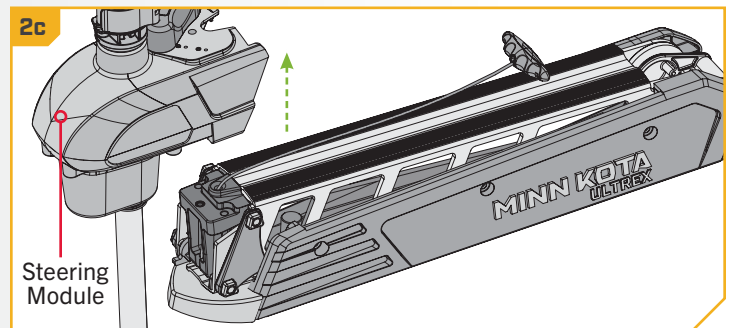
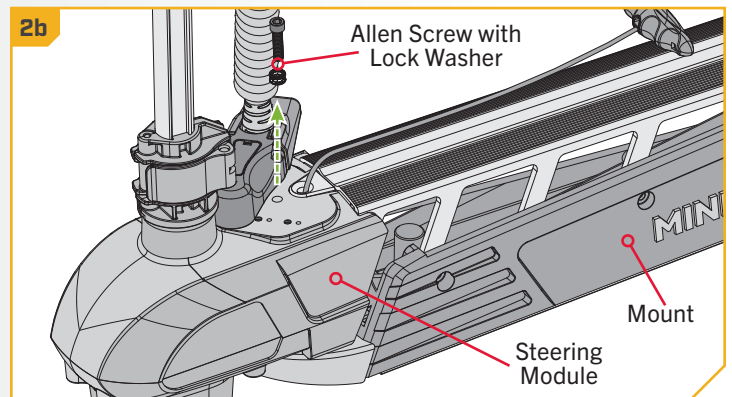

Remove the Gas Spring from the Mount

The Gas Spring should be completely uninstalled to provide access for installing the new Lift Assist Cylinder. Minn Kota recommends having a second person help hold the Mount while the Gas Spring is removed. When the Gas Spring is disconnected, the weight of the Mount is no longer supported. Use the help of a second person to hold and support the Mount while removing the Gas Spring.

1

- a. Reposition the trolling motor by using the Pull Grip and Cable to disengage the Latch Bar on the Mount. Position the motor halfway between the stowed and deployed positions so the Outer Arm is nearly perpendicular to the base of the Mount.

CAUTION

Moving parts can cut or crush. Avoid pinch points when moving and supporting the Mount. Use the help of a second person to support the Mount while working on the installation.

- b. With the two screws removed in the previous step, the end of the Gas Spring previously secured to the Outer Arm can move freely. The Yoke can also move independently when the Gas Spring is detached.

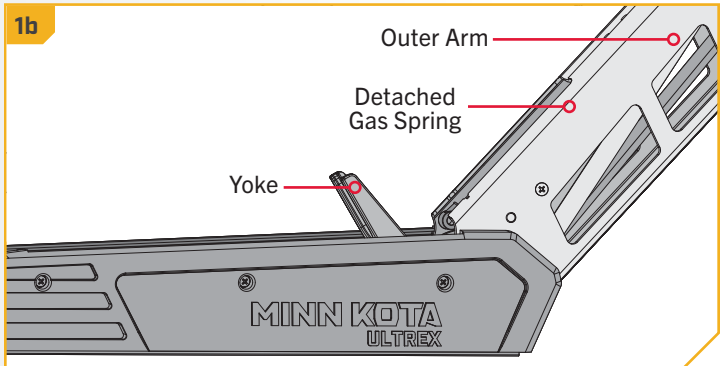
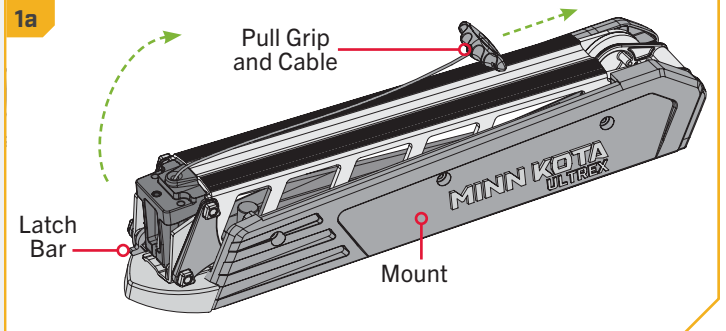

2

- c. Rotate the Yoke upward while guiding the free end of the Gas Spring upward inside the Outer Arm.
- d. The Yoke is rotated far enough upward when the two screws holding the attached Rod End of the Gas Spring to the Yoke are visible above the Sideplate.

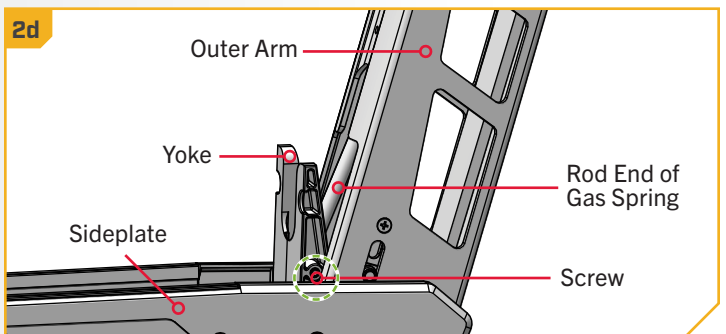
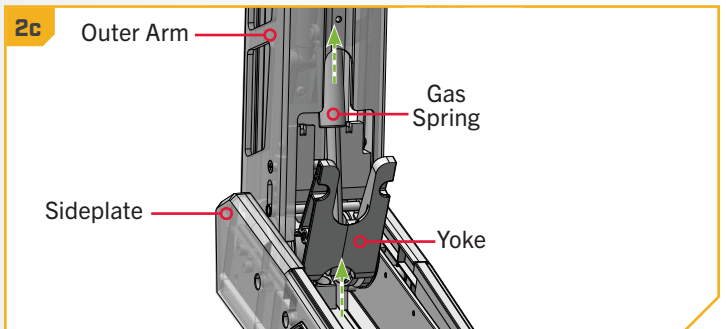

3

- e. With the Yoke rotated, access and remove the two Hex Head Flange Screws holding the Rod End of the Gas Spring to the Yoke. One screw is located on each side of the Yoke. Use a 1/4" Socket Wrench to loosen and remove the Screws. Set the Screws aside for reassembly with the new Lift Assist Cylinder.
- f. With the screws removed, the Gas Spring will be uninstalled from the Yoke and Outer Arm. To remove the Gas Spring from inside the Outer Arm, hold the loose Gas Spring with one hand and rotate the Yoke back toward the Boat Deck with the other hand. Rotating the Yoke clears the opening in the Outer Arm.

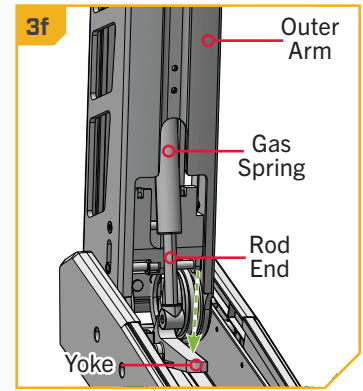
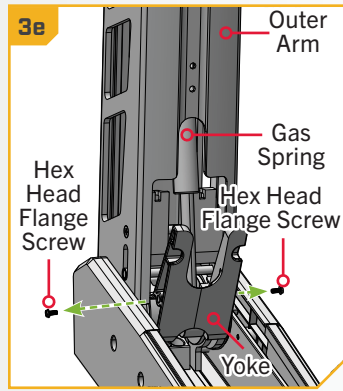

4

- g. Slide the Gas Spring down toward the Boat Deck and out of the Outer Arm. Keep the Mount open. Retain the Gas Spring for re-installation if the Humminbird MEGA 360 Imaging and MEGA Live Imaging TargetLock are removed from the trolling motor. With the original Gas Spring removed, the Mount is ready for the installation of the new Lift Assist Cylinder.

NOTICE: Retain the original Gas Spring. If the Humminbird MEGA 360 Imaging and MEGA Live Imaging TargetLock are removed from the trolling motor, it is necessary to reinstall the original Gas Spring.

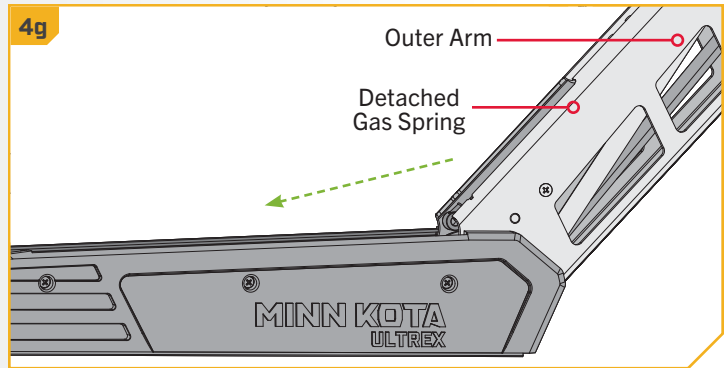

Install the new Lift Assist Cylinder

The Rod End of the Lift Assist Cylinder should be installed before replacing the Steering Module. Installing the Rod End of the Lift Assist Cylinder to the Yoke when the Steering Module is not present allows maximum mobility of the Mount during installation.

1

- a. Use the help of a second person to hold the Mount in place. Ensure the Mount is open and the Outer Arm is nearly perpendicular to the base of the Mount attached to the Boat Deck. The Yoke should be rotated down toward the Boat Deck.
- b. Install the Lift Assist Cylinder by securing the end of the Gas Spring with the Bracket to the inside of the Outer Arm. Secure the opposite Rod End of the Gas Spring to the Yoke. To assemble the Lift Assist Cylinder, feed it into the Outer Arm.
- c. Check the position of the Yoke and rotate it towards the Boat Deck. Rotating the Yoke down provides access to insert the Lift Assist Cylinder into the Outer Arm.

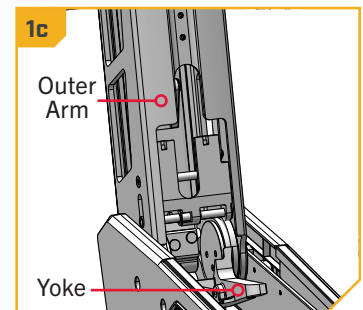
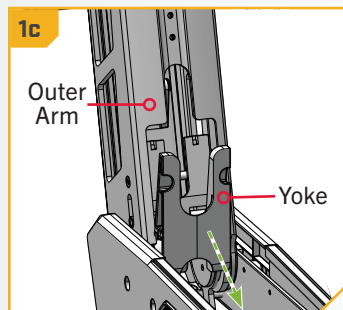
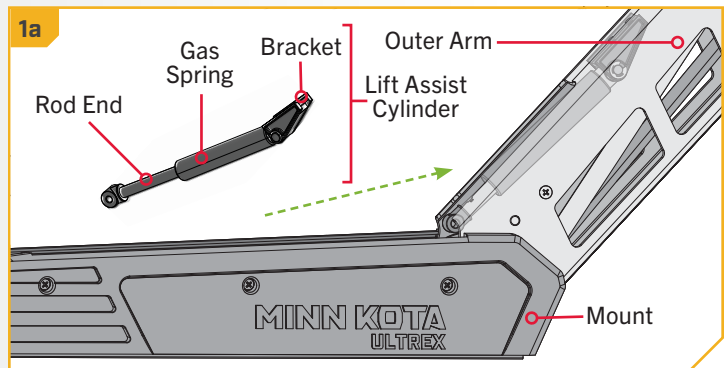

ITEM(S) NEEDED



- d. Take the Lift Assist Cylinder (Item #2) and position it above the open Mount. The Gas Spring should be horizontal to the Boat Deck, with the Bracket pointing toward the Outer Arm between the Sideplates on the Mount. Rotate the Lift Assist Cylinder so that the flat surface of the Bracket is facing upward. The new Lift Assist Cylinder will be fed up into the Outer Arm leading with the Bracket through the same opening in the Outer Arm where the previous Gas Spring was removed.

NOTICE: Ensure the correct Lift Assist Cylinder is installed. The new Lift Assist Cylinder (Item #2) will be labeled with Part #2298411 for 80lb/45" trolling motors, Part #2298403 for 80lb/52" and 112lb/52" trolling motors, or Part #2298412 for 112lb/45" trolling motors.

- e. Insert the Lift Assist Cylinder and raise it until it is almost entirely in the Outer Arm. Confirm it is facing the correct direction with the flat surface of the Bracket against the Outer Arm and that the Mounting Holes are aligned.
- f. Once in the Outer Arm, rotate the Yoke up and align the Holes on each side of the Yoke with the Holes at on the Rod End of the Lift Assist Cylinder.

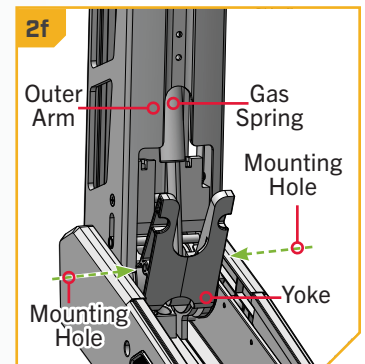
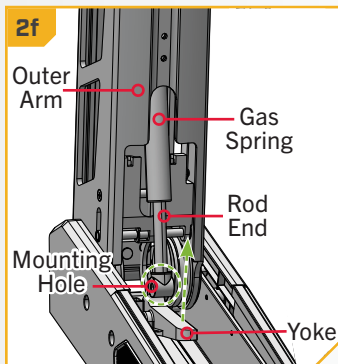
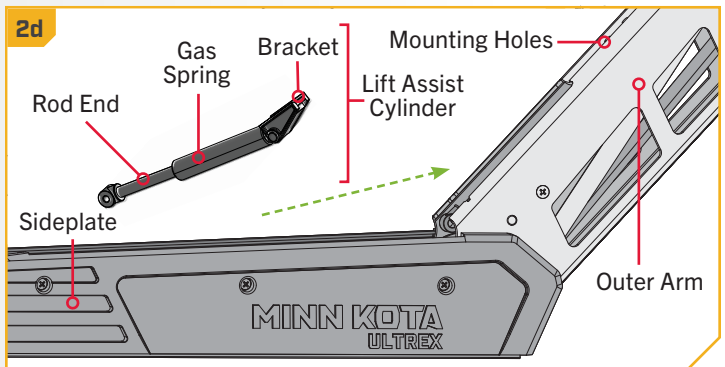
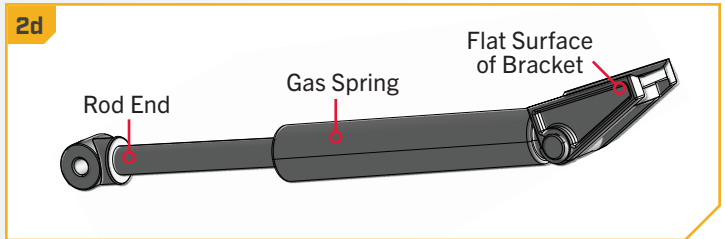

3

- g. Ensure that the Rod End of the Lift Assist Cylinder is aligned correctly. There is one Mounting Hole on each side of the Yoke. Ensure the Yoke is rotated far enough upward so that the Mounting Hole is above the Sideplates.
- h. The Mounting Hole on the Rod End of the Lift Assist Cylinder should sit inside the Yoke. Once aligned, use a 1/4" Socket Wrench to reinstall the two Hex Head Flange Screws that held the previous Gas Spring in place. Tighten to 14 in-lbs. After the Screws are fully installed, the Rod End of the Lift Assist Cylinder is installed to the Yoke.

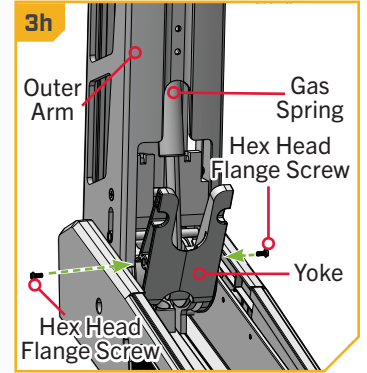
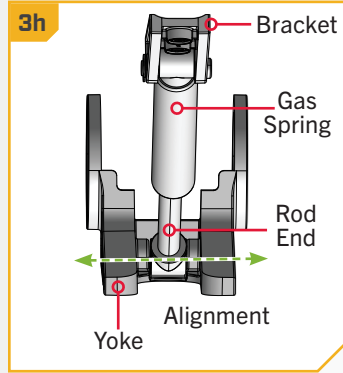
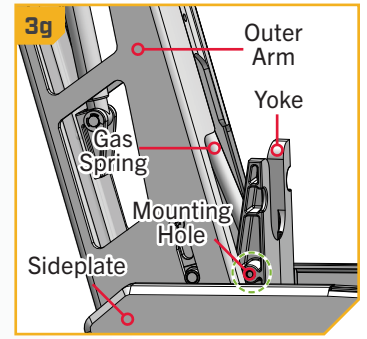
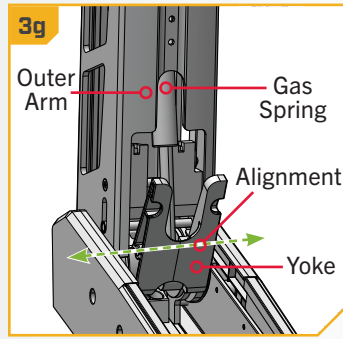

NOTICE: If the Hex Head Flange Screws (Part #2293408) are misplaced, additional screws can be ordered online at minnkota.johnsonoutdoors.com.

NOTICE: Minn Kota recommends applying blue thread locker to the Hex Head Flange Screws before reinstalling.

Reinstall the Steering Module

Replace the Steering Module before connecting the Lift Assist Cylinder to ensure that the weight from the Steering Module and Humminbird accessories is dispersed when the Lift Assist Cylinder installation is complete. The Lift Assist Cylinder can become damaged when moving the Mount, and the damage will prevent the Lift Assist feature from operating correctly. Make sure that the Lift Assist Cylinder does not get damaged when positioning the Mount.

1

- a. To reassemble the Steering Module, start with the Mount in the deployed position. Take care when positioning the Mount into the deployed position so that the Lift Assist Cylinder does not get damaged. A damaged Lift Assist Cylinder will not function properly.
- b. Align the Keyways on the inside of the Steering Module with the End Links on the Mount. Do this by positioning the Steering Module above the End Links on the Mount. Lower the Steering Module straight down until seated.

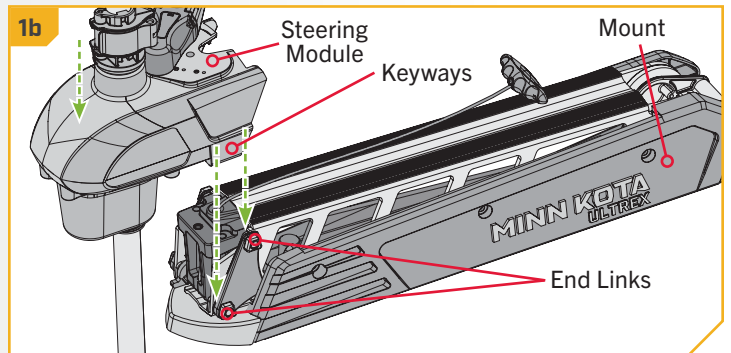

2

- c. Reinstall the 5/16" Allen Screw and Lock Washer with a 1/4" Allen Wrench and tighten to 18 to 20 ft-lbs with a Torque Wrench.

NOTICE: The 5/16" Allen Screws must be tightened when installed and periodically tightened to 18 to 20 ft-lbs. Tighten the Allen Screws when the Mount is in the deployed position.

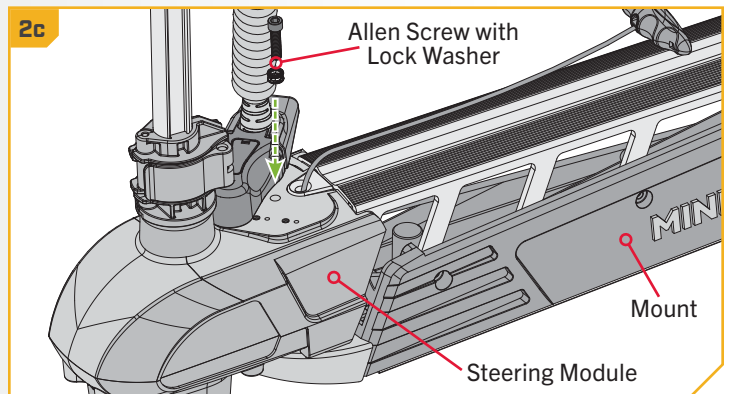

Connect the Lift Assist Cylinder

The final step is installing the new Lift Assist Cylinder to gain the benefits of the new cylinder is to secure it to the Outer Arm. Take care to stow and position the motor to connect the List Assist Cylinder to prevent damage to the Gas Spring. Minn Kota recommends using the help of a second person to position and secure the Mount during this final step of the installation.

1

- Use the Pull Grip and Cable to disengage the Latch Bar on the Mount.
- Position the motor so that it is halfway between the stowed and deployed position. Allow the motor to be positioned so that the Lower Unit rests on the Motor Ramp.

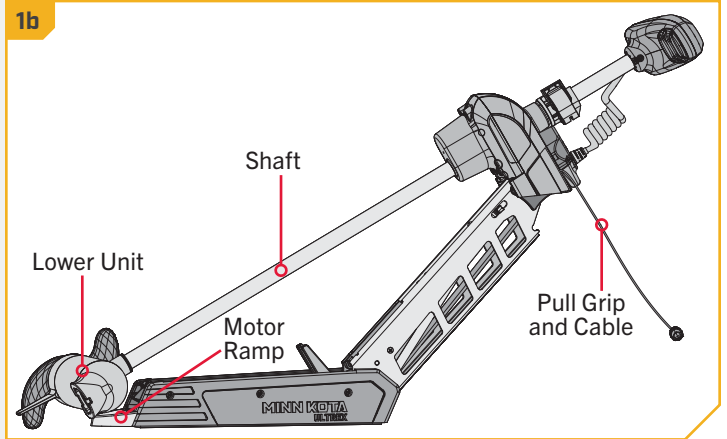
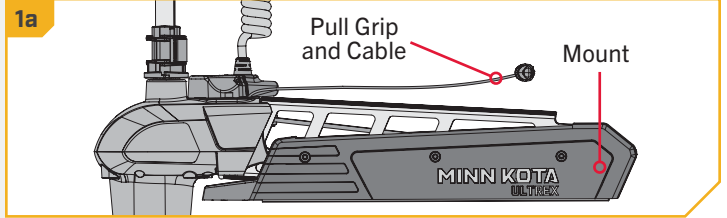

CAUTION

Moving parts can cut or crush. Avoid pinch points when moving and supporting the Mount. Use the help of a second person to support the Mount while working on the installation.

NOTICE: The Lift Assist Cylinder can become damaged when moving the Mount, and the damage will prevent the Lift Assist feature from operating correctly. Make sure that the Lift Assist Cylinder does not get damaged in the Mount.

2

ITEM(S) NEEDED



- Carefully rotate the Yoke back towards the Boat Deck with one hand and guide the Gas Spring inside the Outer Arm. Align the Bracket with the two holes in the Outer Arm. Adjust the motor as needed to align the Bracket.
- Take two Pan Head Phillips Machine Screws (Item #4) and install them through the holes in the Outer Arm and into the Bracket at the end of the Lift Assist Cylinder using a #3 Screwdriver. Tighten to 35 in-lbs.
- Once reinstalled, stow and deploy the trolling motor to ensure proper operation.

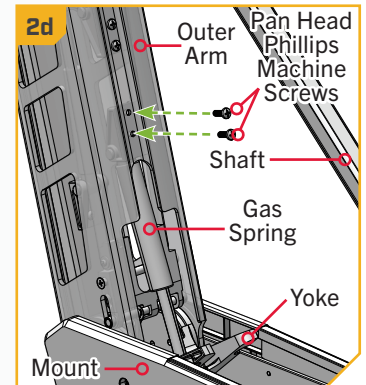
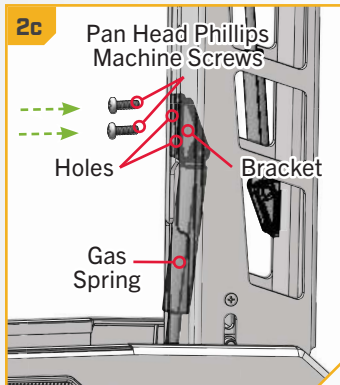

NOTICE: To order additional Phillips Head Machine Screws (Part #2373434) visit the Online Parts Ordering Portal at minnkota.johnsonoutdoors.com.

For warranty information, please visit minnkota.johnsonoutdoors.com.



Minn Kota Consumer & Technical Service
Johnson Outdoors Marine Electronics, Inc.
PO Box 8129
Mankato, MN 56001

121 Power Drive
Mankato, MN 56001
Phone (800) 227-6433
Fax (800) 527-4464



©2023 Johnson Outdoors Marine Electronics, Inc.
All rights reserved.