

# STOWING AND DEPLOYING IN SHALLOW WATER

## STOWING AND DEPLOYING IN SHALLOW WATER

For trolling motors with a 72" shaft, the Stow Lock Collar will be required to secure the Shaft when deployed in shallow water. Due to the position of the Coil Cord Slider, the Depth Collar cannot be placed beyond the midpoint of the Shaft to hold the depth of the lower unit when deploying in shallow water. The Stow Lock Collar should be used instead to perform this function.

**NOTICE:** Straining against the Coil Cord Slider to place the Depth Collar too low on the Shaft may cause stress or excessive force on trolling motor components.

### › Deploying in Shallow Water (72" Shafts)

- 1**
  - a. Power on the trolling motor.
  - b. Ensure that the Depth Collar is secured on the Shaft and will not slide around while deploying.
  - c. Unlock the Stow Lock Collar by flipping the Lock Arm to the unlocked  position.

### **WARNING**

When stowing or deploying the motor, keep fingers clear of all hinge and pivot points and all moving parts.

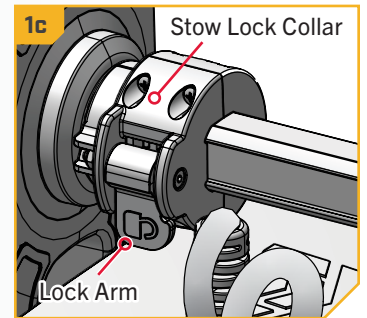
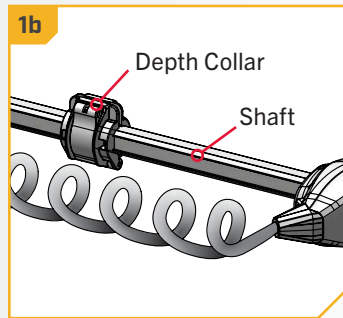

# STOWING AND DEPLOYING IN SHALLOW WATER

2

## WARNING

The spaces between the Depth Collar, Coil Cord Slider, and Stow Lock Collar can create pinch points. Do not come into contact with an area that may cause a pinch point when it is moving in any direction to avoid risk.

The Control Head will create a pinch point if the Control Head slides to the top of the Depth Collar. Grasp the Shaft to prevent it from sliding all the way down and creating a pinch point.

Practice proper ergonomics when stowing and deploying the motor to prevent injury.

## CAUTION

If the Keel Offset has been configured, and Straight On Deploy is toggled "on," the motor will automatically rotate into the Keel Offset position when the Shaft is fully vertical and the Steering Housing locks into the deployed position. Be aware of this motion to avoid suddenly releasing the Shaft and to avoid contacting pinch points.

- d. Firmly grasp the Shaft or Control Head, then press the Stow Deploy Lever at the base of the mount to release the Fall Away Ramps.
- e. Guide the Lower Unit out and away from the Fall Away Ramps. Maintain a secure hold while guiding the motor to the deployed position. Allow the Lower Unit to drop and tilt so that the Shaft is vertical.
- f. Lower the motor to the desired depth.
- g. While holding the motor at the proper depth, lock the Stow Lock Collar  to secure the motor. Be sure to press the Lock Arm so that it is fully seated against the Stow Lock Collar.

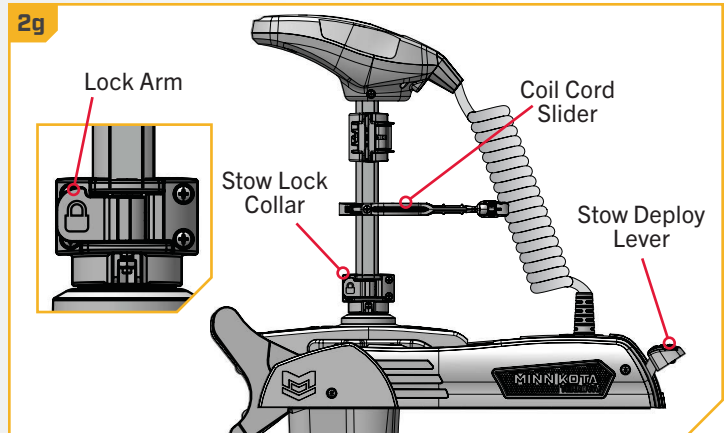
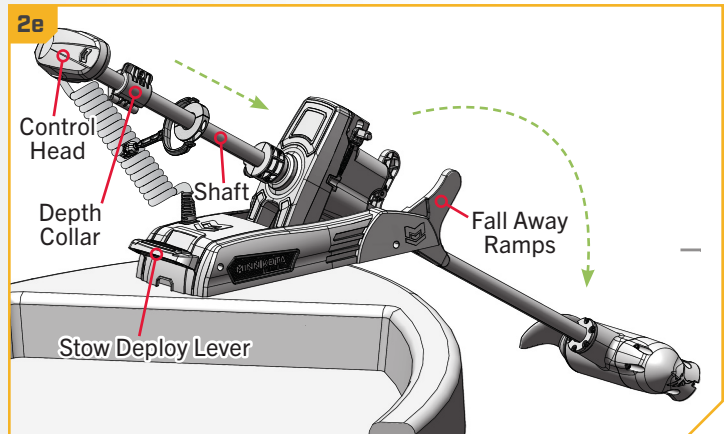

# STOWING AND DEPLOYING IN SHALLOW WATER

## 1 Stowing in Shallow Water (72" Shafts)

1

### **WARNING**

When stowing or deploying the motor, keep fingers clear of all hinge and pivot points and all moving parts.

**NOTICE:** Leave no less than 8" of space between the bottom of the Steering Housing and the top of the Lower Unit when tilting the motor into the stowed position. If the Lower Unit is trimmed too high before tilting the motor, the Lower Unit will collide with the Mount and be unable to stow.



**NOTICE:** When stowing the motor, ensure that the area between the Mount and Steering Housing is clean and free of debris. The Mount contains pads that contact the Steering Housing when stowed. The motor cannot stow securely if an obstruction is present on the pads.

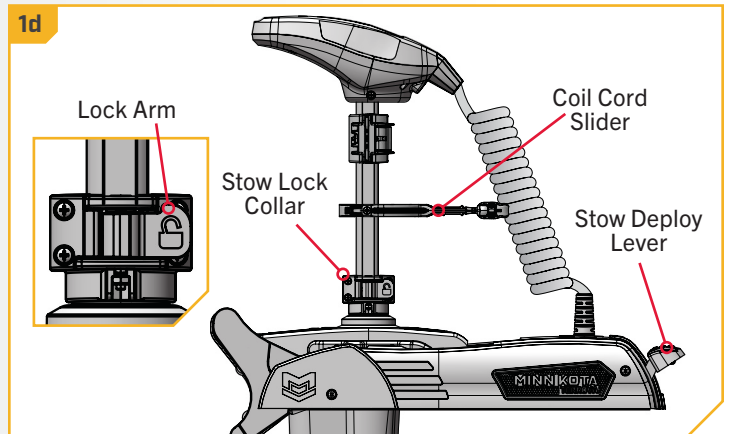
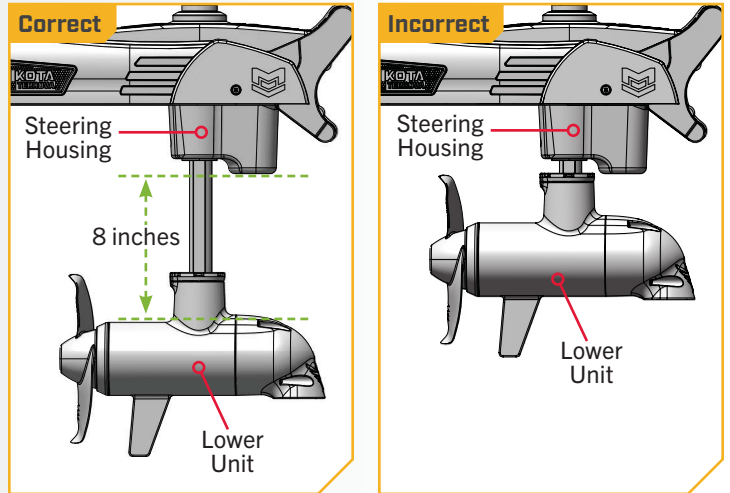

- Power on the trolling motor.
- Press the Stow Deploy Lever at the front of the mount. This will cause the Shaft and Lower Unit to automatically rotate into the Stow Orientation. Allow the Lower Unit to complete this motion before stowing the motor.
- Firmly grasp the Shaft or Control Head. Maintain a secure hold throughout the entire stowing process.
- Unlock the Stow Lock Collar by flipping the Lock Arm to the unlocked  position.



## STOWING AND DEPLOYING IN SHALLOW WATER

2

- e. While holding down the Stow Deploy Lever, pull the Shaft upward to raise the Lower Unit. Tilt the Shaft into a horizontal position while guiding the motor toward the Fall Away Ramps. Pull the Lower Unit fully onto the Ramps. The Fall Away Ramps will latch upright and the STOWED  LED on the Indicator Panel will illuminate orange when the motor is properly stowed.
- f. Secure the motor in place by flipping the Lock Arm on the Stow Lock Collar into the locked  position. Ensure that the Lock Arm is fully seated against the Stow Lock Collar.

**NOTICE:** The trolling motor is not safely stowed for transport until the orange STOWED  LED is illuminated, the Fall Away Ramps are latched upright with the Lower Unit in place, and the Stow Lock Collar is locked .

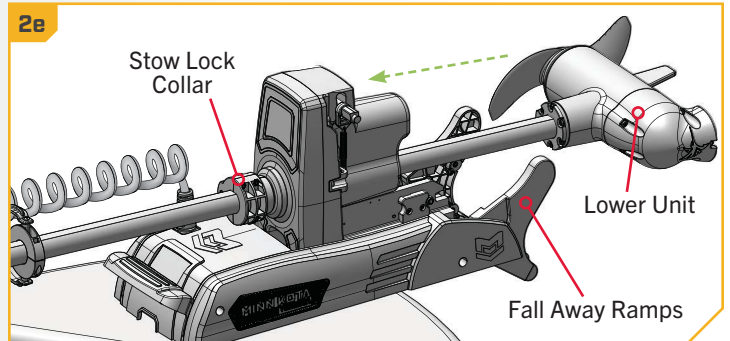

### WARNING

When the motor is stowed, the Stow Lock Collar must be in the locked  position to prevent accidental deployment. Accidental Deployment may result in injury or damage to the trolling motor, accessories, or boat.

## MOTOR ADJUSTMENTS >

### ADJUSTING THE DEPTH OF THE MOTOR

Once the boat is on the water, it may be necessary to adjust the Lower Unit up or down to achieve an optimum depth for motor performance. When setting the depth of the motor, be sure the top of the motor is submerged at least 12" below the surface of the water to avoid churning or agitation of surface water.

#### > Adjusting the Depth of the Motor (45" and 60" Shafts)

1

- a. With the motor in the deployed position, firmly grasp the Shaft or Control Head. Maintain a secure hold throughout the entire adjustment.



## WARNING

The Control Head will create a pinch point if the Depth Collar is released and the Control Head slides to the top of the Depth Collar. Grasp the Shaft to prevent it from sliding all the way down and creating a pinch point.

- b. Lift up on the Shaft, then release the Depth Collar by opening the Cam Lever.
- c. Raise or lower the motor to the desired depth.
- d. Place the Depth Collar against the Steering Housing and close the Cam Lever to lock the Depth Collar and secure the Shaft.

**NOTICE:** Ensure that the top of the lower unit is submerged at least 12" below the surface of the water to avoid churning or agitation of surface water.

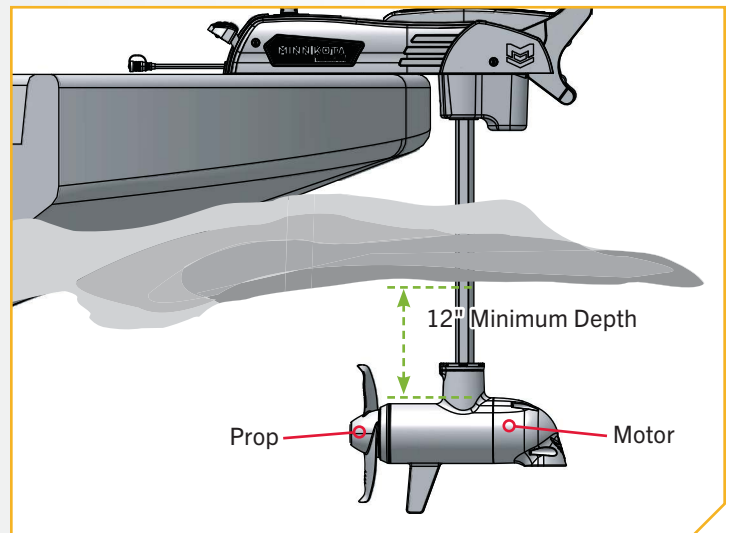
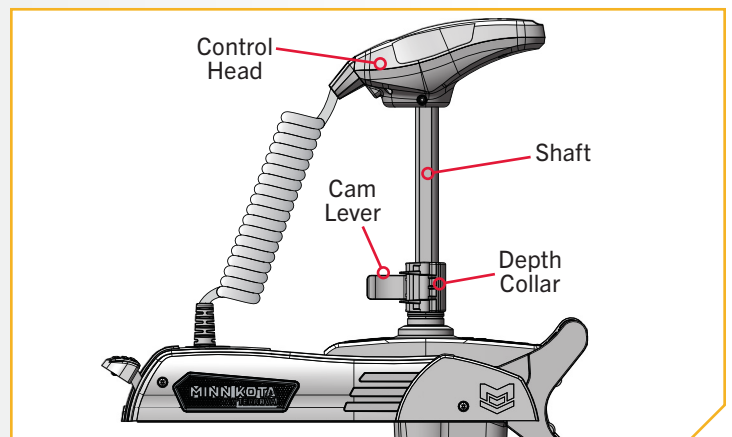

# ADJUSTING THE DEPTH OF THE MOTOR

## Adjusting the Depth of the Motor (72" Shafts)

1

- a. With the motor in the deployed position, firmly grasp the Shaft or Control Head. Maintain a secure hold throughout the entire adjustment.



### WARNING

The spaces between the Depth Collar, Coil Cord Slider, and Stow Lock Collar can create pinch points. Avoid contacting an area that may cause a pinch point when it is moving in any direction to avoid risk.

The Control Head will create a pinch point if the Control Head slides to the top of the Depth Collar. Grasp the Shaft to prevent it from sliding all the way down and creating a pinch point.

Practice proper ergonomics when stowing and deploying the motor to prevent injury.

- b. Lift up on the Shaft, then release the Depth Collar by opening the Cam Lever.
- c. Ensure that the Stow Lock Collar is in the unlocked  position.
- d. Raise or lower the motor to the desired depth.
- e. Place the Depth Collar down as far as it will go against the Coil Cord Slider and Stow Lock Collar on the Steering Housing. Close the Cam Lever to lock the Depth Collar and secure the Shaft.
- f. If deployed in shallow water, and the Depth Collar cannot be placed beyond the Coil Cord Slider to secure the Shaft, lock the Stow Lock Collar to secure the Shaft at the proper depth.

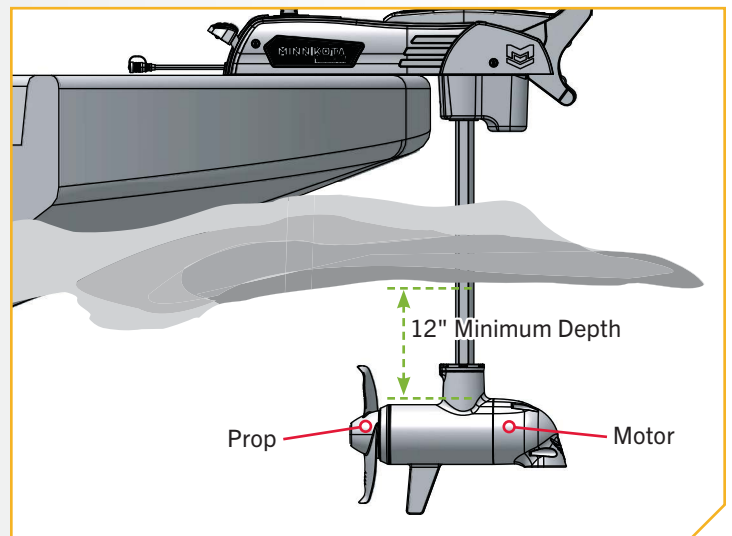
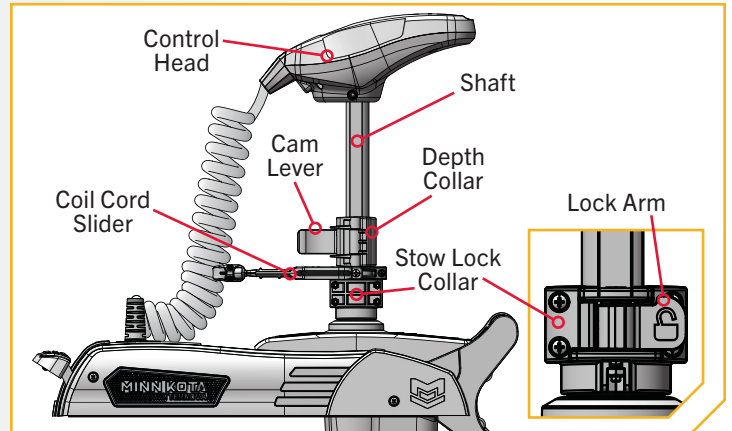

**NOTICE:** Ensure that the top of the lower unit is submerged at least 12" below the surface of the water to avoid churning or agitation of surface water.



# ADJUSTING THE LOWER UNIT FOR A SECURE STOW

## ADJUSTING THE LOWER UNIT FOR A SECURE STOW

When the Motor is stowed, the Lower Unit should rest on the Fall Away Ramps. It is recommended to secure the motor using the following instructions to avoid damage to the motor and Shaft from vibrations during transport.

### › Adjusting the Lower Unit for a Secure Stow (45" and 60" Shafts)

1

- a. Before transporting the boat over water or land, stow the motor to ensure the Lower Unit rests properly on the Fall Away Ramps. When stowing the motor, the Lower Unit should be pulled fully onto the Fall Away Ramps, which rotate up to cradle the Lower Unit in the stowed position. The STOWED  LED on the Indicator Panel will illuminate orange when the Fall Away Ramps latch upright.
- b. If the Lower Unit does not sit on the Fall Away Ramps, press the Stow Deploy Lever and adjust the motor to allow the Lower Unit to rest on the Ramps.
- c. With the Lower Unit in place on the Ramps, and the orange STOWED  LED illuminated on the Indicator Panel, slide the Depth Collar down against the Steering Housing and close the Cam Lever to secure the motor.

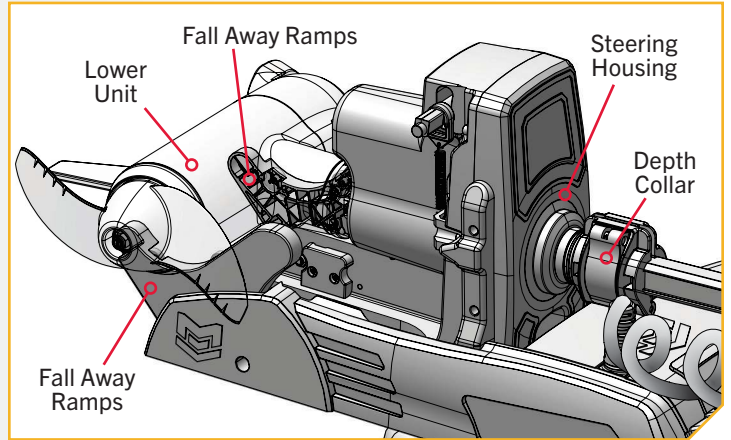

**NOTICE:** To secure the motor in place and prevent accidental deployment when stowed, slide the Depth Collar down against the top of the Steering Housing and close the Cam Lever to lock the Depth Collar.

### CAUTION

The Lower Unit should be placed on the Fall Away Ramps every time the motor is transported. If the Lower Unit is improperly placed, damage to the Lower Unit or Shaft will occur. Failure to follow the recommended placement for the Lower Unit will cause damage to the product and void your product warranty.



### WARNING

When the motor is being transported, it is important to place the Depth Collar snug against the Steering Housing and close the Cam Lever to lock the Depth Collar. This provides a secure stow and holds the motor in place during transportation when it is subject to high levels of shock and vibration. Failure to secure the motor may result in injury or damage to the unit.

# ADJUSTING THE LOWER UNIT FOR A SECURE STOW

## › Adjusting the Lower Unit for a Secure Stow (72" Shafts)

1

- a. Before transporting the boat over water or land, stow the motor to ensure the Lower Unit rests properly on the Fall Away Ramps. When stowing the motor, the Lower Unit should be pulled fully onto the Fall Away Ramps, which rotate up to cradle the Lower Unit in the stowed position. The STOWED  LED on the Indicator Panel will illuminate orange when the Fall Away Ramps latch upright.
- b. If the Lower Unit does not sit on the Fall Away Ramps, press the Stow Deploy Lever and adjust the motor to allow the Lower Unit to rest on the Ramps.
- c. With the Lower Unit in place on the Ramps, and the orange STOWED  LED illuminated on the Indicator Panel, secure the motor in place by flipping the Lock Arm on the Stow Lock Collar into the locked  position. Ensure that the Lock Arm is fully seated against the Stow Lock Collar.

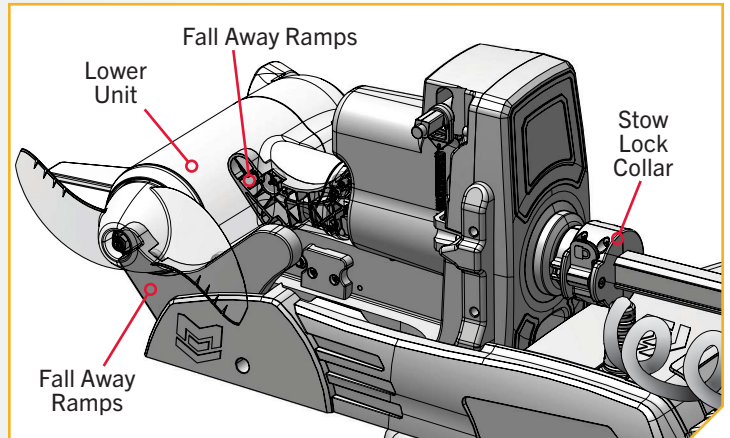

**NOTICE:** To secure the motor in place and prevent accidental deployment when stowed, lock the Stow Lock Collar . Be sure to press the Lock Arm so that it is fully seated against the Stow Lock Collar.

### CAUTION

The Lower Unit should be placed on the Fall Away Ramps every time the motor is transported. If the Lower Unit is improperly placed, damage to the Lower Unit or Shaft will occur. Failure to follow the recommended placement for the Lower Unit will cause damage to the product and void your product warranty.

### WARNING

When the motor is being transported, it is important to fully lock  the Stow Lock Collar. This provides a secure stow and holds the motor in place during transportation when it is subject to high levels of shock and vibration. Failure to secure the motor may result in injury or damage to the unit.



## ROTATING THE DEPTH COLLAR

The Depth Collar is installed from the factory so that the Cam Lever opens in an upward motion when the Stow Orientation of the lower unit is Prop Left. The factory default Stow Orientation is Prop Left. Stow Orientation can be changed to Prop Right using the wireless remote or One-Boat Network app. For more information about Stow Orientation, refer to the "One-Boat Network" section of this manual.

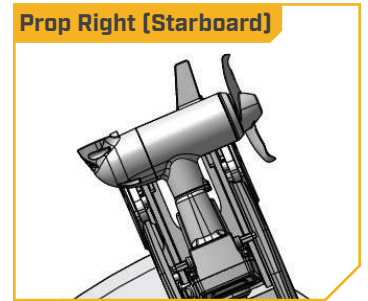
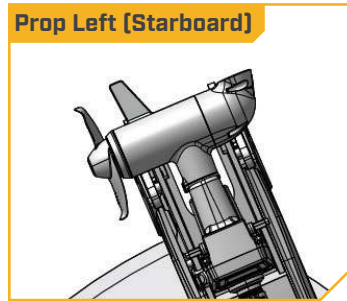
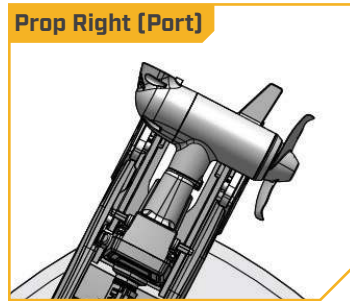
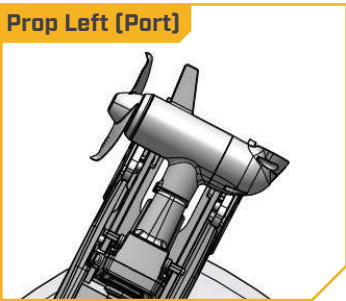

A Prop Right orientation turns the lower unit and shaft when stowed, causing the Depth Collar to open downward. This reduces its range of motion and creates an obstruction when placing the Depth Collar for a secure stow.

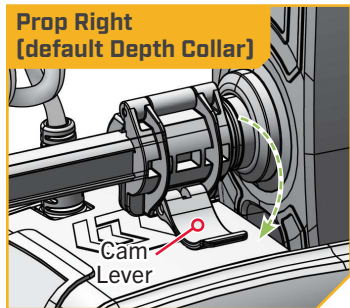
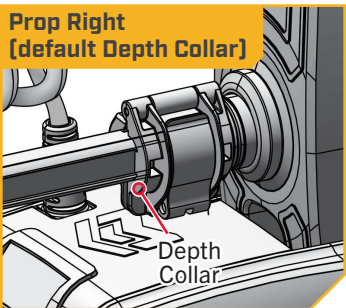

If the Stow Orientation is changed to Prop Right, the Depth Collar must be rotated on the shaft to improve accessibility. The Depth Collar is positioned correctly on the Shaft when the Cam Lever opens upward when the motor is stowed.

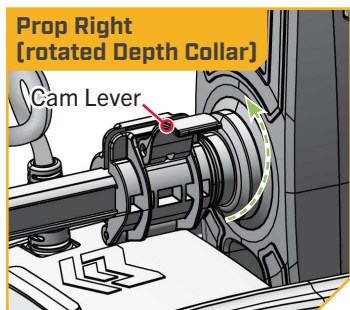
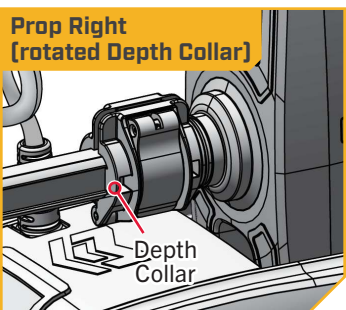

### TOOLS AND RESOURCES REQUIRED >

- #3 Phillips Screwdriver

# ROTATING THE DEPTH COLLAR

## INSTALLATION >

1

- a. With the Stow Orientation set to Prop Right, stow the trolling motor. Ensure that the Lower Unit is resting securely on the Fall Away Ramps and that the STOWED LED on the Indicator Panel is illuminated orange.
- b. Release the Depth Collar by opening the Cam Lever.
- c. Locate the single Screw on the back side of the Depth Collar. This Screw secures the Cam Lever.
- d. Using a #3 Phillips Screwdriver, and with the Cam Lever open, remove the Screw from the Depth Collar. While loosening the Screw, gently open the halves of the Depth Collar to access a Spring inside. This Spring sits between the Depth Collar halves and is retained by the Screw. Take the Spring and place it onto the Screw, then set both aside for reassembly later.
- e. Remove the Cam Lever from the Depth Collar and set it aside. There is a Pin contained in the Cam Lever. If the Pin slides out, place it back in before reassembly.

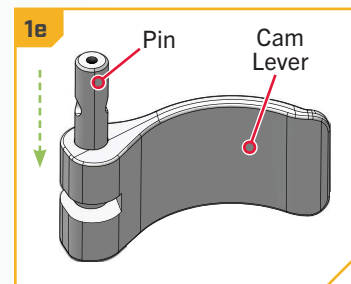
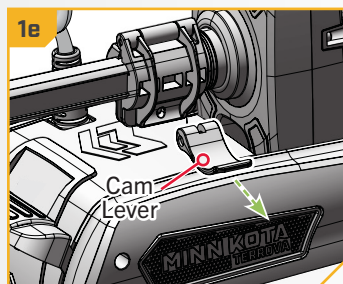
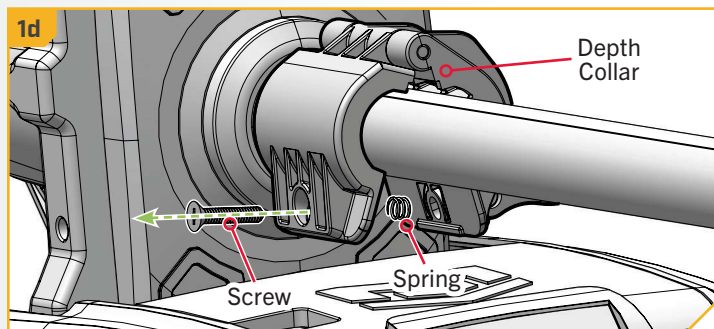
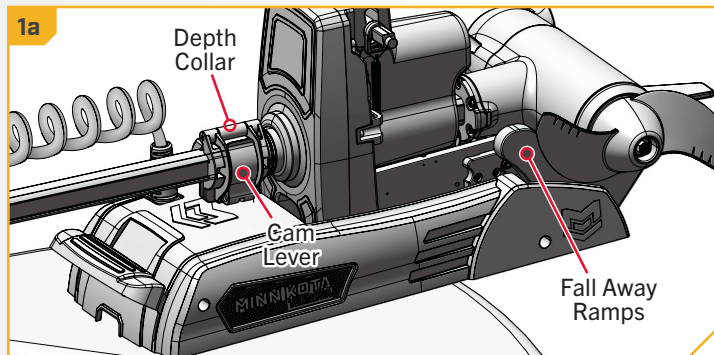

## ROTATING THE DEPTH COLLAR

2

- f. Remove the Depth Collar from the Shaft. Turn the Depth Collar 180° so that the screw hole in the Depth Collar sits above the Shaft.
- g. Place the Depth Collar on the Shaft in the new position. For motors with a 72" shaft, the Depth Collar should sit between the Control Head and Coil Cord Slider. On motors with a 45" or 60" shaft, the Depth Collar can sit anywhere between the Control Head and Steering Housing.
- h. Pay attention to the shape of the Depth Collar halves and ensure that they close correctly around the Shaft. The Friction Pad inside the Depth Collar should sit against the groove of the Shaft.

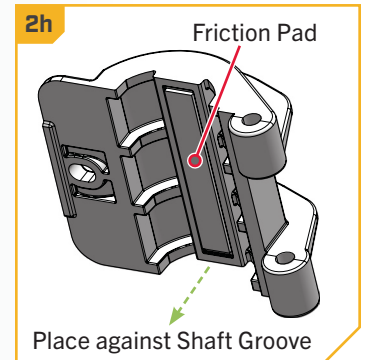
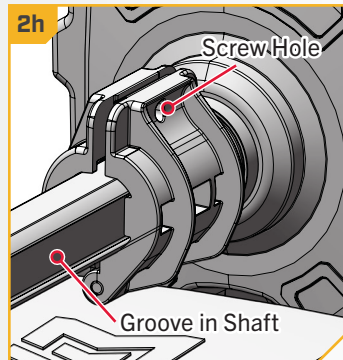
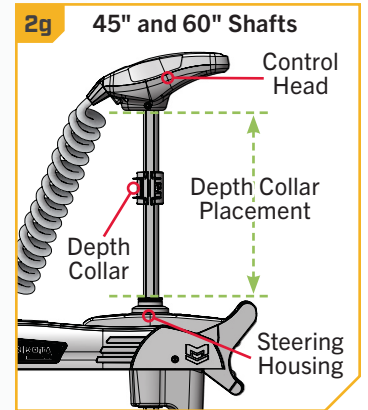
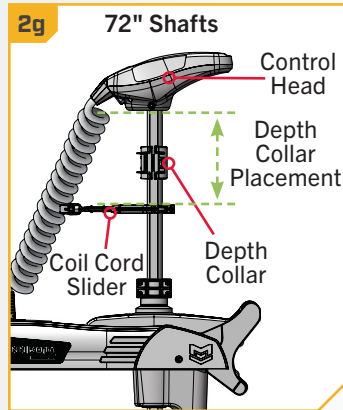
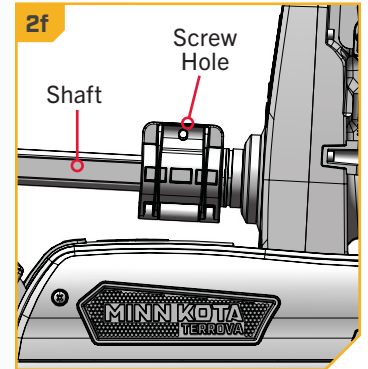
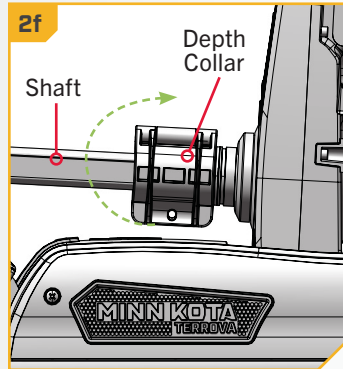

## ROTATING THE DEPTH COLLAR

3

- i. With the Depth Collar in position on the Shaft, take the Screw and Spring that were removed earlier in the installation. Hold the Spring inside the Depth Collar against the screw hole. The Spring should sit between the Depth Collar halves. Insert the Screw into the Depth Collar so that it passes through the Spring and out the second half of the Depth Collar.
- j. Take the Cam Lever and ensure that the Pin is inside. Hold the Cam Lever in position against the Depth Collar, with the threaded hole in the Pin positioned towards the Screw. Pay attention to the shape of the Cam Lever and hold it so it curves over to wrap around the Depth Collar. When positioned correctly, the curve in the Cam Lever should follow the shape of the Depth Collar when closed. Attaching the Cam Lever upside down will prevent the Depth Collar from closing.
- k. Using a #3 Phillips Screwdriver, hold the Screw steady while aligning the Pin in the Cam Lever. It may be necessary to rotate the Pin inside the Cam Lever so that the threaded hole aligns with the Screw. Begin tightening the Screw so it catches the Pin. When the Screw engages with the Pin, close the Cam Lever to lock the Depth Collar. Finish tightening the Screw to 60 in-lbs.
- l. Ensure that the Cam Lever is neither too loose nor too tight. If the Cam Lever is too tight, it will be difficult to open or close and the Depth Collar will not move, even when unlocked. If the Cam Lever is too loose, the Depth Collar will not securely hold the Shaft even when locked. If the Depth Collar can be forcibly pushed up or down the Shaft when locked, the Collar is too loose. Recheck the tension of the Screw and tighten or loosen as needed.

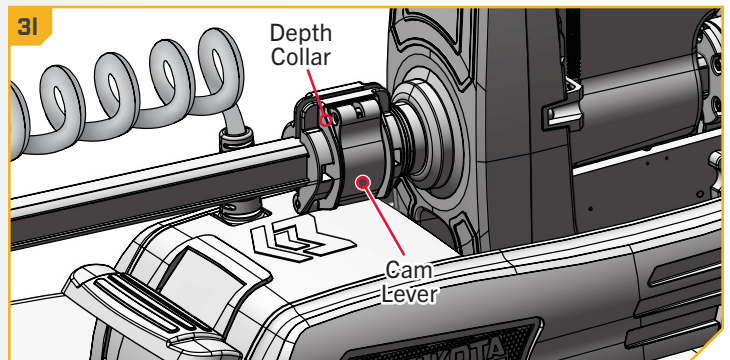
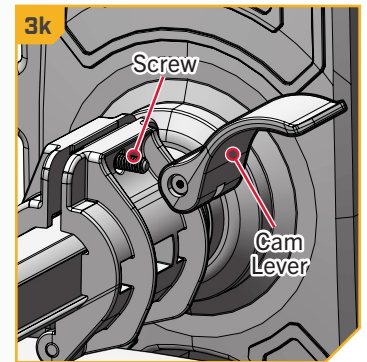
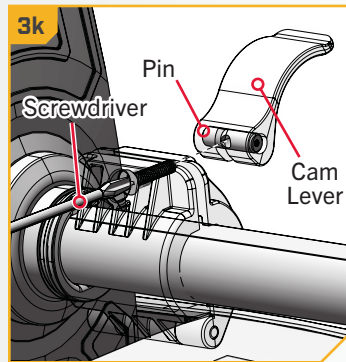
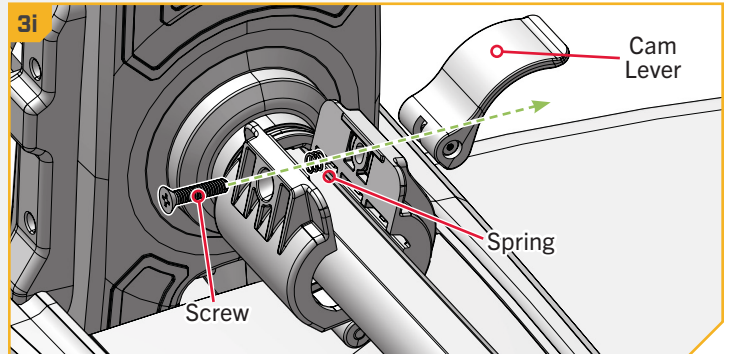

# ADJUSTING THE STOW LOCK COLLAR TENSION

## ADJUSTING THE STOW LOCK COLLAR TENSION

The tension on the Stow Lock Collar is adjustable and can be tightened or loosened as needed. The Stow Lock Collar may wear and loosen over time. If the Stow Lock Collar is no longer securely holding the Shaft when in the locked position, it may be necessary to tighten the Lock Arm on the Collar.

### TOOLS AND RESOURCES REQUIRED >

- 1/8" Hex Head Screwdriver
- 3/8" Socket Wrench

### INSTALLATION >

- Stow the trolling motor. Ensure that the Lower Unit is resting securely on the Fall Away Ramps.
  - Unlock the Stow Lock Collar.
  - Use a 1/8" Hex Head Screwdriver to loosen the Shoulder Bolt and Nylock Nut that secure the Lock Arm to the Stow Lock Collar. Loosen the Bolt in a counterclockwise direction. Remove the Bolt and Nylock Nut and set aside for reassembly later.
  - With the Bolt removed, pull the Lock Arm out of the Stow Lock Collar. The tension adjustment for the Stow Lock Collar is made using the Lock Arm.

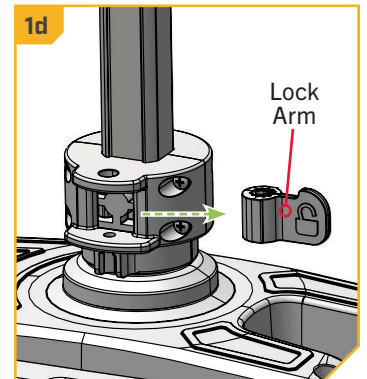
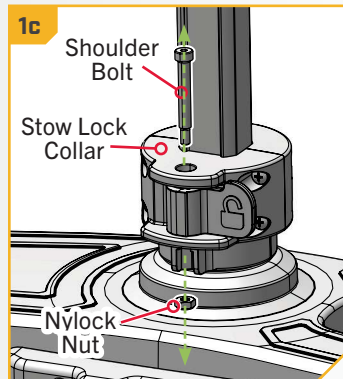

## ADJUSTING THE STOW LOCK COLLAR TENSION

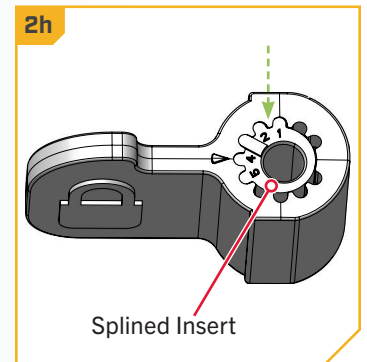
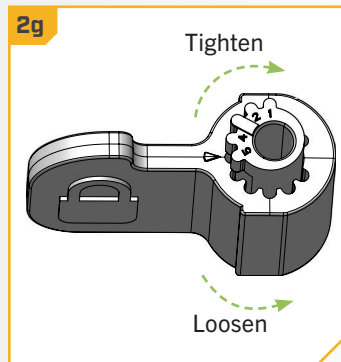
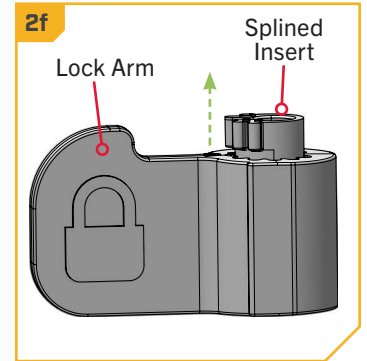
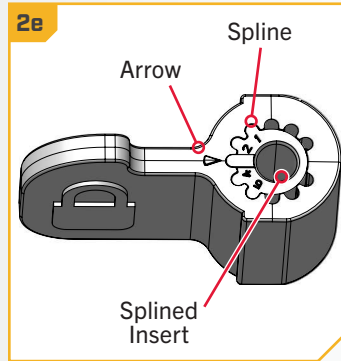

2

- e. Molded into the plastic on top of the Lock Arm is a small arrow. The arrow points to a Splined Insert contained within the Lock Arm. The larger the number in front of the arrow, the higher the tension on the Stow Lock Collar. The Splined Insert within the Lock Arm contains five Splines that are used to adjust the tension. The Stow Lock Collar comes from the factory with the middle Spline aligned to the arrow.
- f. Lift the Splined Insert from the center of the Lock Arm so the Splines are raised and free to rotate.
- g. To tighten the Lock Arm on the Stow Lock Collar, rotate the Splined Insert one Spline clockwise. To loosen the grip of the Lock Arm, rotate the Insert one Spline counterclockwise. A smaller number will be looser, a larger number will be tighter.
- h. When the desired Spline tension is in line with the arrow, press the Splined Insert back into the Lock Arm so that the Insert is fully seated.



## ADJUSTING THE STOW LOCK COLLAR TENSION

3

- i. To reassemble, hold the Lock Arm so that the Splined Insert faces the Control Head.
- j. Align the hole in the Lock Arm with the holes in the base of the Stow Lock Collar. Hold the Lock Arm so it is in the unlocked position.
- k. Insert the Shoulder Bolt into the Stow Lock Collar so it passes through the Lock Arm and out the hex-keyed recess.
- l. Insert the Nylock Nut into the hex-keyed recess. The flat side of the Nylock Nut should face toward the Control Head, while the rounded edge should face down.
- m. With a 1/8" Hex Bit Screwdriver and 3/8" Socket Wrench, hand-tighten the Shoulder Bolt. The Nylock Nut should sit flat when tight and be snug with the plastic of the Stow Lock Collar. Threads should stick out slightly and be visible past the end of the Nylock Nut.
- n. Close the Lock Arm on the Stow Lock Collar so that it is in the locked  position. Test the security of the Stow Lock Collar by pressing the Stow Deploy Lever to release the Fall Away Ramps, then trying to push the Lower Unit out horizontally and away from the Ramps. If the motor holds successfully, the adjustment is complete. If the motor moves when pushed, pull the Lower Unit back onto the Fall Away Ramps. Remove the Lock Arm and turn the Splined Insert clockwise an additional Spline. Reassemble the Stow Lock Collar and repeat the test until the motor can no longer be moved when the Stow Lock Collar is in the locked  position.

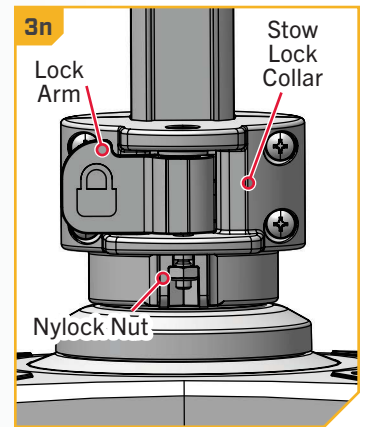
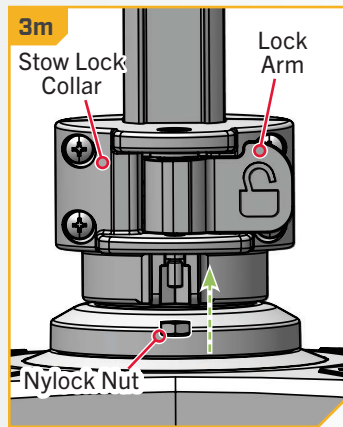
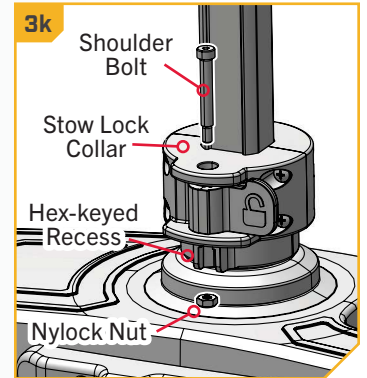
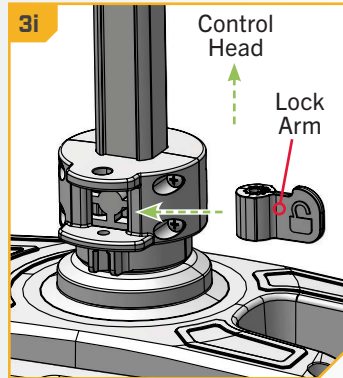

**NOTICE:** If the Stow Lock Collar is too tight, the Shaft will not move freely even when the Stow Lock Collar is unlocked. If the Stow Lock Collar is too loose, it will not securely hold the Shaft when locked.

# INSTALLING AN EXTERNAL TRANSDUCER

## INSTALLING AN EXTERNAL TRANSDUCER

An external transducer is not included with your trolling motor. An external transducer can be installed onto motors that have Advanced GPS Navigation. Installing an external transducer is not recommended for motors with Built-in MEGA Imaging.

- 1
  - a. Mount the External Transducer according to directions provided with the transducer.
  - b. Leave enough slack in the Transducer Cable between the Lower Unit and Control Head to allow the motor to properly stow and deploy.
  - c. Use two Cable Ties to secure the Transducer Cable to the Shaft just below the Control Head.
  - d. Run the Transducer Cable through the Coil Cord to the fish finder.

### CAUTION

Failure to follow the recommended wire routing for the External Transducer may cause damage to the product and void your product warranty. Test the length and placement of cable to ensure that there is enough slack where needed. Ensure that cables will be free and not become entangled in moving parts. Routing the cables in any way other than directed may cause damage to the cables by being pinched or severed.

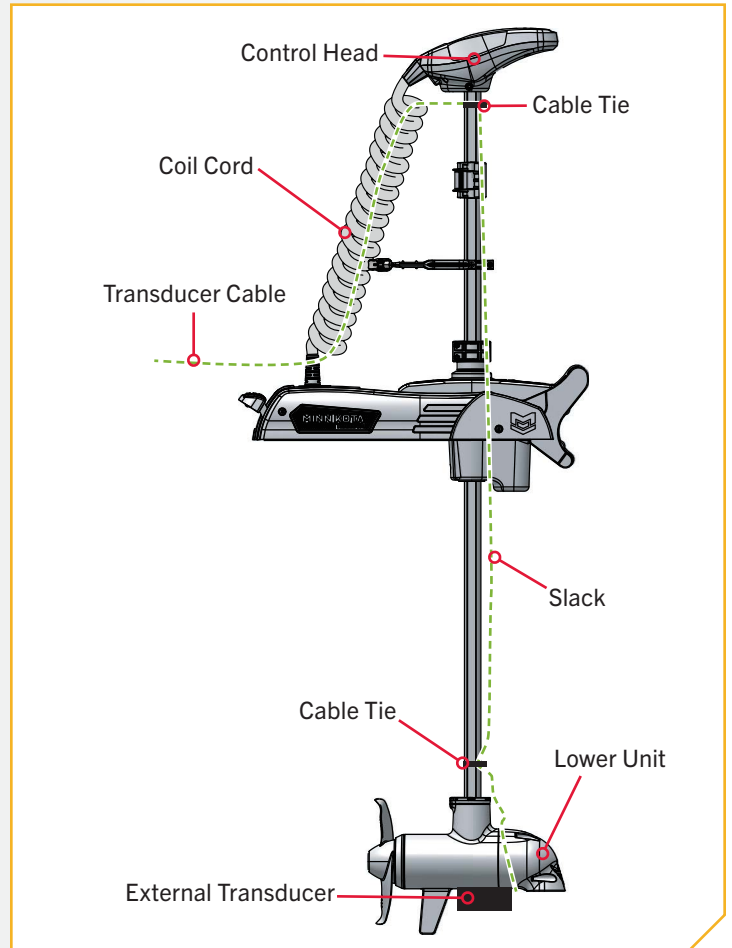



# USING THE FOOT PEDAL

## CONTROLLING SPEED & STEERING WITH THE FOOT PEDAL

The Foot Pedal is used to operate the Terrova QUEST trolling motor. The controls on the Foot Pedal are easy to use. The trolling motor can also be controlled by the Advanced GPS Navigation wireless remote or any compatible Minn Kota remote. Please refer to the associated remote manual for instructions.

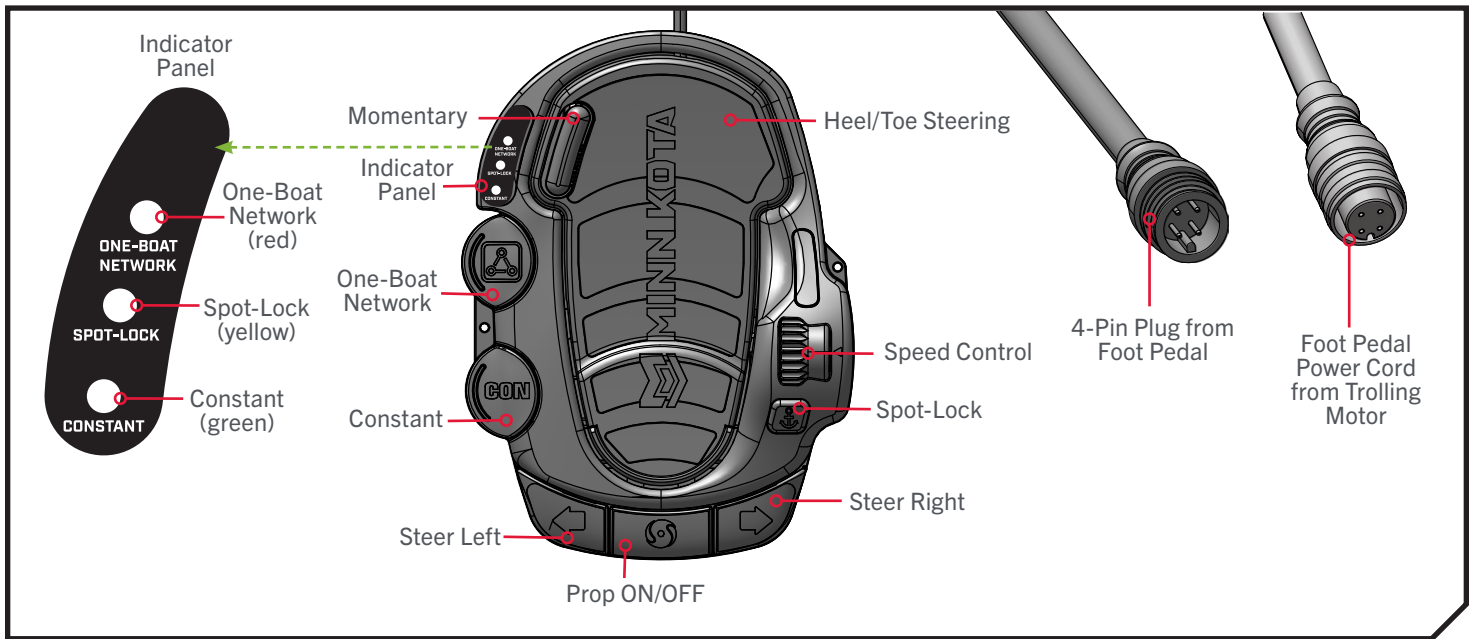

## FOOT PEDAL OPERATION

### › Motor Speed



The Speed Control Knob is located above the Spot-Lock button on the right side of the Foot Pedal. Turn the Speed Control Knob forward to increase speed and backward to decrease speed. The Speed Control Knob can be set in a range from 0 to 10. Speed can also be adjusted using a remote or the One-Boat Network app.



## WARNING

Practice proper ergonomics when operating the foot pedal to prevent injury.

### › Spot-Lock

The Spot-Lock  button is located on the bottom right side of the Foot Pedal and is labeled with an anchor symbol. When the Spot-Lock button is pressed, the location of the motor is recorded to a temporary Spot-Lock location. The yellow SPOT-LOCK  LED on the Indicator Panel is illuminated when Spot-Lock is engaged. To engage Spot-Lock, press the Spot-Lock button. To disengage, press the Spot-Lock button again. In the default Audio Mode, a tone is emitted from the Control Head when Spot-Lock is engaged. If the Audio Mode is set to Alarm Only, a tone will not be emitted when Spot-Lock is engaged. To learn more about Audio Modes, refer to the owner's manual for the One-Boat Network app. When disengaging Spot-Lock with the Spot-Lock button, no tone will be emitted from the Control Head. Steering the motor with the Foot Pedal or adjusting the speed using the Speed Control Knob will cancel Spot-Lock, and a High-Low, High-Low, High-Low tone will be emitted from the Control Head. Spot-Lock can be controlled with the Wireless Remote or the One-Boat Network app. For more specific information, please refer to the accessory owner's manual online at [minnkota.johnsonoutdoors.com](http://minnkota.johnsonoutdoors.com).

# FOOT PEDAL OPERATION



## **WARNING**

You are responsible for the safe and prudent operation of your vessel. We have designed the foot pedal to be an accurate and reliable tool that will enhance boat operation and improve your ability to catch fish. This product does not relieve you from the responsibility for the safe operation of your boat. You must avoid hazards to navigation and always maintain a permanent watch so you can respond to situations as they develop. You must always be prepared to regain manual control of your boat. Learn to operate your foot pedal and trolling motor in an area free from hazards and obstacles.

### › **Steer Right/Steer Left**

The Steer Right ⇨ and Steer Left ⇩ buttons are located at the bottom of the Foot Pedal. They function to steer the trolling motor to the right and left. Holding the Steer Right or Steer Left buttons down will continue to steer the motor to the left or right. Small steering changes of less than one degree can be made by quickly tapping the Steer Right and Steer Left buttons.

**NOTICE:** The motor will not auto correct to drive straight when it encounters an obstruction.



## **CAUTION**

The steering system is designed to turn your motor 460 degrees. Be careful to avoid over-wrapping the Coil Cord around the trolling motor Shaft.

### › **Prop ON/OFF**

The Prop ON/OFF  button is located in the middle, at the bottom of the Foot Pedal. It functions to momentarily turn the Prop on and off. The Prop will turn on when pressure is applied and off when the pressure on the button is removed. The Prop button does not change the behavior of the Prop when the Constant button is engaged.

### › **Constant**

The Constant  button is located on the left side of the Foot Pedal, towards the bottom, below the One-Boat Network button. It functions to toggle the motor between Constant motor operation and Momentary motor operation. The green **CONSTANT**  LED on the Indicator Panel will be illuminated when the motor is in Constant motor operation. In Constant motor operation, the propeller will continually run, regardless of whether or not force is being applied to the Momentary button or Prop ON/OFF button. While in Constant motor operation, the propeller will run continuously at the speed set by the Speed Control Knob, the Wireless Remote, or the One-Boat Network app.

If the propeller encounters an obstruction while in Momentary or Constant motor operation while running, the increased electrical current generated by the obstruction will signal the motor to decrease the power to the Prop to prevent damage.

### › **Momentary**

In Momentary motor operation, the Prop will only run while a downward force is applied to the Momentary button. The Momentary button is on the Toe End of the pedal. Applying downward pressure to the Momentary button will turn the Prop “on.” The motor will then run at the speed set by the Speed Control Knob, the Wireless Remote, or the One-Boat Network app. Removing downward force from the Momentary button will turn the Prop off. No indicator light is associated with the Momentary button. The Momentary button functions similarly to the Prop ON/OFF button.







## › Heel/Toe Steering

Push the Toe End of the Foot Pedal down to turn right, and push the Heel End of the Foot Pedal down to turn left. The position and direction of the Control Head directly correspond to the position of the motor. Use your foot on the Foot Pedal to control the steering direction during manual operation. The direction of the trolling motor can also be controlled with the Wireless Remote and the One-Boat Network app.

## › One-Boat Network

The One-Boat Network (OBN)  button is located in the middle, on the left side of the Foot Pedal. It is a customizable button that may change functions based on user selection. Pressing the OBN button will activate the assigned OBN function. The red One-Boat Network (OBN)  LED on the Indicator Panel is illuminated when this feature is engaged. Each function has a different LED pattern. AutoPilot is the default OBN function. Please review the “One-Boat Network” section of these instructions to learn more.



# AUTOPILOT

## AUTOPILOT AND THE ONE-BOAT NETWORK

AutoPilot on the Advanced GPS Navigation System uses an internal compass to keep the trolling motor pointed in the same compass direction. If the One-Boat Network (OBN)  button on the Advanced GPS Navigation System on the Foot Pedal is customized to the AutoPilot function, the button will engage and disengage AutoPilot.

## AUTOPILOT MODES

Two different modes of AutoPilot are available, Locked Heading AutoPilot and Locked Course AutoPilot. Both are collectively referred to as AutoPilot. There are distinct differences between the two AutoPilot Modes and how they control the boat. Both Locked Heading and Locked Course AutoPilot are valuable tools anglers can use for accurate and precise bait presentation. Minn Kota highly recommends getting on the water and trying both Locked Heading AutoPilot and Locked Course AutoPilot in various fishing situations and applications. The AutoPilot mode can be set using the Wireless Remote or the One-Boat Network app.

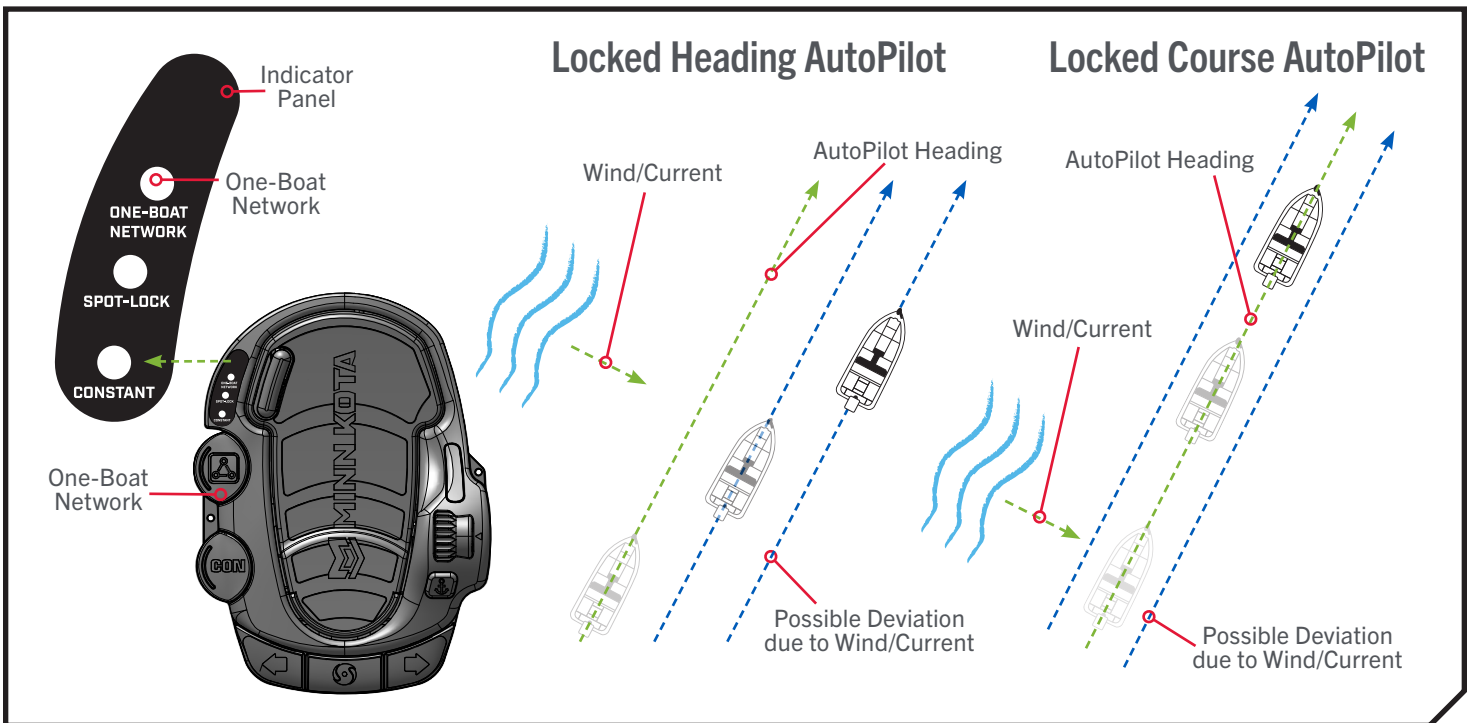

### › Locked Heading AutoPilot

AutoPilot uses an internal compass to provide heading lock. When Locked Heading AutoPilot is on, it keeps the motor pointed in the same compass direction. If a manual steering correction is made, Locked Heading AutoPilot locks onto the new compass heading to which the boat was steered. This method of heading tracking does not take into account external forces such as a side wind or currents, which can allow side drift.

### › Locked Course AutoPilot

Locked Course AutoPilot uses not only compass heading but also GPS data to correct for crosswinds, currents, and other external forces to keep the boat on the intended course. When Locked Course AutoPilot is turned on, it creates a course that the trolling motor will follow. When the user steers to a new heading, a new course is created. Locked Course AutoPilot will keep the boat on the course in most conditions. When very extreme conditions exist, such as very strong winds or currents, the trolling motor may not have enough power to control the boat smoothly. In these extreme cases, it may be best to use Locked Heading AutoPilot and let the boat move with the wind or current if the motor is not powerful enough to overcome it.

**⚠ CAUTION**

This unit uses a magnetic compass to detect the direction of travel. The compass can be adversely affected by magnets or large, ferrous metal objects near (within 12" of) the trolling motor control head.

Obstructions on the Prop may cause excessive vibration of the motor control head. This vibration can cause the compass to wander and erratic steering to occur. Clear the obstruction to return the motor to normal operation.



The trolling motor has automatic steering shutdown for safety. In conditions where an obstruction prevents the trolling motor from turning, or in extremely windy conditions, the automatic steering may stop. Any steering input will reset the system to normal.

When AutoPilot is "on" and the trolling motor is pulled out of the water to the stow position, the steering motor will continue to run until the motor is stowed properly. Once the motor is stowed properly, AutoPilot will turn "off," and the AutoPilot Indicator will no longer be illuminated.

› **Toggle AutoPilot On/Off**

When AutoPilot is on, and the trolling motor is pulled out of the water to the stow position, the steering motor will continue to run. Turn AutoPilot off to stop the motor. If AutoPilot is left on, the steering motor will shut off automatically after ten seconds. The motor should not be stored in this condition for long periods as power is still being applied to all electronics. Always turn AutoPilot off and disconnect your motor from the battery when storing your boat.

**1**

- a. While the motor is running, AutoPilot can be turned on by pressing the One-Boat Network  button located on the Foot Pedal.
- b. The red One-Boat Network  LED on the Indicator Panel will illuminate when AutoPilot is engaged. While AutoPilot is on, steer the trolling motor as desired.

**NOTICE:** After steering to a new direction, there is a short delay before the direction is locked in to allow the compass to stabilize. When broad speed changes are made, the AutoPilot heading may change slightly. This is normal.

- c. To turn AutoPilot "off," press the One-Boat Network  button.

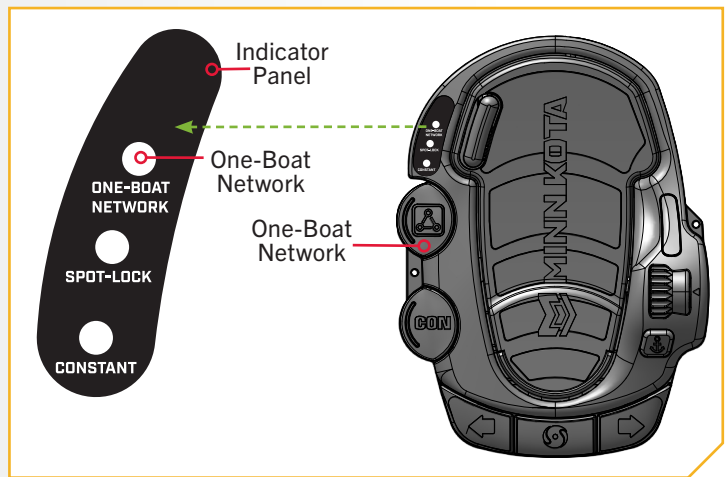

**⚠ CAUTION**

When the AutoPilot is on, and the trolling motor is pulled out of the water to the stow position, the steering motor will continue to run. Turn AutoPilot off to stop the motor. If AutoPilot is left on, the steering motor will shut off automatically after ten seconds. The trolling motor should not be stored in this condition for long periods as power is still being applied to all electronics. Always turn AutoPilot "off" and disconnect your motor from the battery when storing your boat.

# WAYPOINTS

## WAYPOINTS AND THE ONE-BOAT NETWORK

Waypoints are saved latitude/longitude positions. They mark a position of interest, such as favorite fishing areas, structures, or marker buoys. Waypoints work similarly to Spot-Locks. If the One-Boat Network (OBN)  button on the Foot Pedal is customized to the Waypoint function, the button will mark Waypoints in the Advanced GPS Navigation System when pressed. For more information on working with Waypoints, please see the Advanced GPS Navigation System or Humminbird owner's manual.

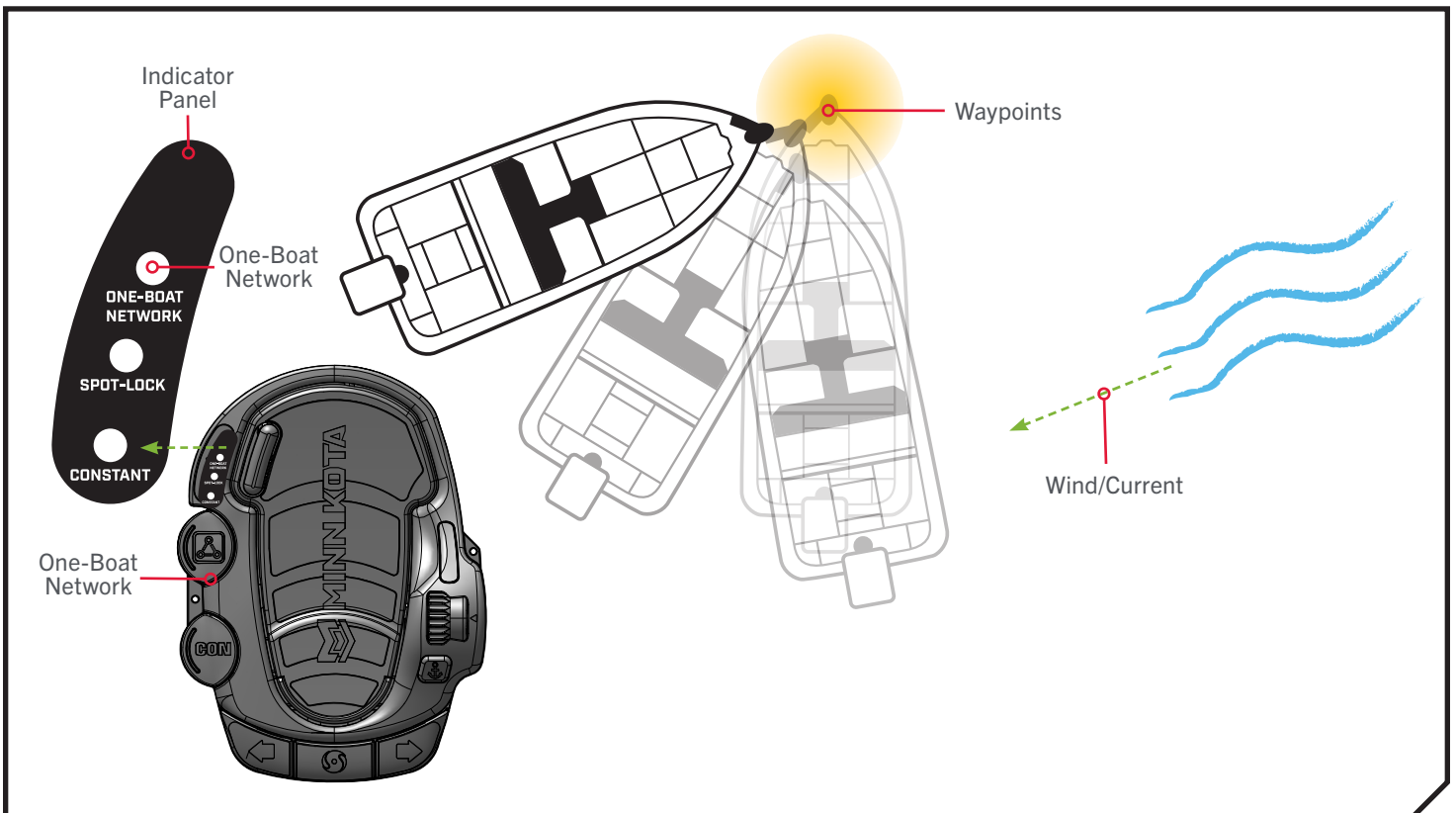

### **WARNING**

Watch for a turning Prop when working with Waypoints. Auto Prop On is set to "off" by default on the Advanced GPS Navigation System. If Auto Prop On is turned "on," the Prop will automatically turn on when a Waypoint is engaged, even if the engagement is accidental. A turning Prop can cause injury. If Auto Prop On is turned "off," the Prop must be enabled before the boat will begin navigating to a Waypoint.



## › Mark a Waypoint

1

- a. While the trolling motor is running, mark a Waypoint by pressing the One-Boat Network  button. The red One-Boat Network  LED on the Indicator Panel will briefly illuminate and then turn off to indicate a Waypoint is marked.

**NOTICE:** Refer to the "One-Boat Network" section of these instructions to learn how to customize the function of the One-Boat Network button on the Foot Pedal.

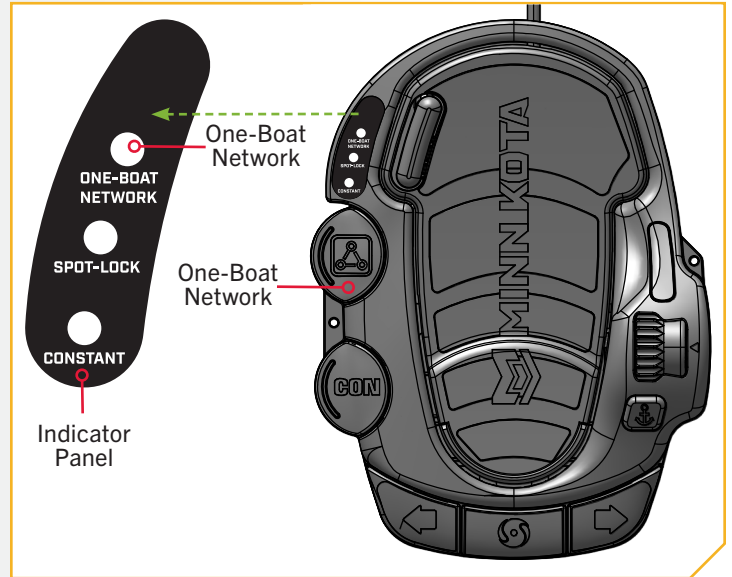

# SHALLOW WATER ANCHOR

## SHALLOW WATER ANCHOR CONTROL AND THE ONE-BOAT NETWORK

The One-Boat Network allows for control of a Shallow Water Anchor (SWA) when one is paired with the Advanced GPS Navigation Bluetooth Network. SWAs that can pair with the Advanced GPS Navigation system include the Minn Kota Bluetooth enabled Raptor and Talon. For more information on how to pair the SWA with the Advanced GPS Navigation system, please see the owner's manual.

When two Raptors are paired together or two Talons are paired together, the anchor selected and controlled by the Foot Pedal can be Port, Starboard or both. To change the selection of which anchor is selected, use the remote or app paired to the Shallow Water Anchor.

### **WARNING**

Be sure that the Raptor/Talon is clear of obstructions and persons while deploying or retracting. Take care that neither you nor other persons approach the Raptor/Talon too closely while operating, neither with body parts nor with objects. The Raptor/Talon is powerful and may endanger or injure you or others. While the Raptor/Talon is operating, watch out for persons swimming and for floating objects. Persons who lack the ability to run the Raptor/Talon or whose reactions are impaired by alcohol, drugs, medication, or other substances are not permitted to use this product.

### **CAUTION**

The Talon is equipped with a Deployment Notification Alarm. The Alarm is needed to comply with warranty requirements and when properly installed the alarm will only sound when the ignition key is turned on when the Talon is not fully retracted. Boat control may be affected by a deployed Talon. Take note of the Alarm, and always watch to make sure that the Talon is fully retracted while the boat is operating.

### **CAUTION**

The spaces between the Outer Arm, Inner Arm, Spike and brackets of the Raptor can create a pinch point. Do not come in contact with an area of the Raptor that may cause a pinch point while it is moving in any direction to avoid the risk.



## Deploy the Shallow Water Anchor

1

- a. Check to make sure that the Shallow Water Anchor (Raptor/Talon) is powered “on” and paired to the One-Boat Network app.
- b. Locate the One-Boat Network  button on the Foot Pedal and double-press it to deploy the Raptor/Talon.

**NOTICE:** The One-Boat Network button does not need to be held in to keep the Raptor/Talon deploying. The Raptor/Talon will automatically continue to deploy when the button is double-pressed until it has reached its full deployment, received input to stop, or anchors.

- c. The red One-Boat Network  LED on the Indicator Panel will steadily flash when the anchor is deploying and stay on when the anchor is at any state of deployment.

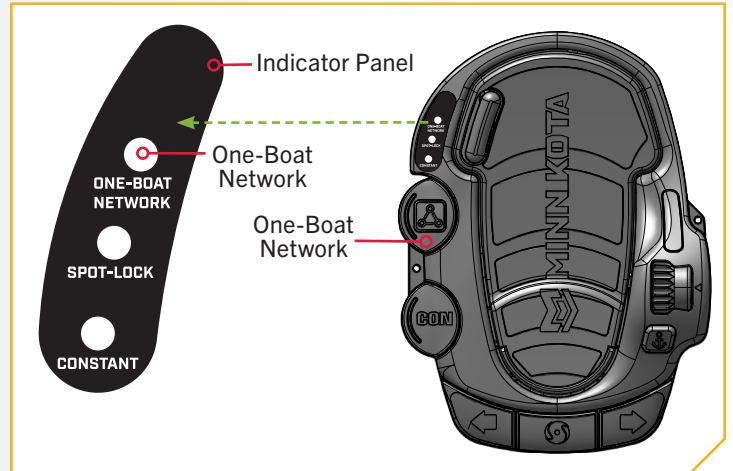

**NOTICE:** While the Raptor/Talon is deploying, the action can be paused by pressing the One-Boat Network button on the Foot Pedal.

## Retract the Shallow Water Anchor

1

- a. Check to make sure that the Shallow Water Anchor (Raptor/Talon) is powered “on” and paired to the One-Boat Network app.
- b. Locate the One-Boat Network  button on the Foot Pedal and press it to retract the Raptor/Talon.

**NOTICE:** While the Raptor/Talon is retracting, the action can be paused by pressing the One-Boat Network button on the Foot Pedal.

- c. The red One-Boat Network  LED on the Indicator Panel will steadily flash when the anchor is retracting and stay on when the anchor is at any state of deployment.

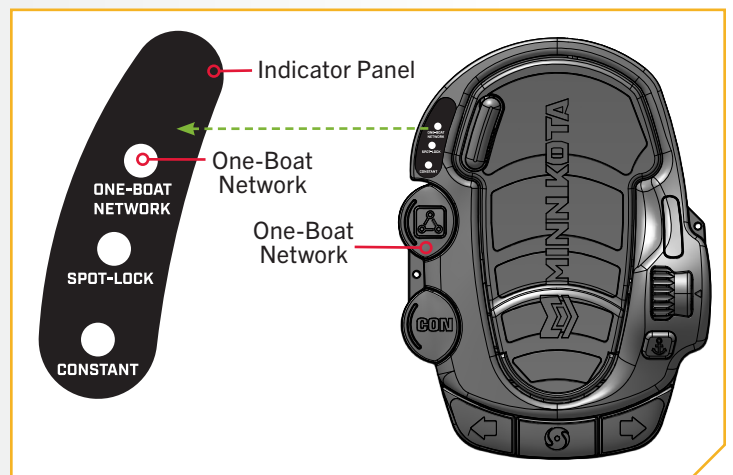

# SPOT-LOCK

## HOW SPOT-LOCK WORKS

Spot-Lock uses a single point of reference that is recorded when the Spot-Lock  button is pressed. The reference point is a set of GPS coordinates captured at the location of the trolling motor at the moment the button is pressed. This point is recorded and can be saved into one of the Spot-Lock memory locations. Spot-Lock works by recognizing the GPS coordinates and will automatically navigate the boat to keep it at the Spot-Lock location. If your motor recognizes it is not positioned at the Spot-Lock location, it will control motor speed and direction in an attempt to keep the motor on the Spot-Lock. For more specific instructions on using Spot-Lock, please refer to the Wireless Remote owner's manual.

**NOTICE:** Spot-Lock is based on the location of the trolling motor, not on the location or direction of the boat. Outside forces such as wind and current will cause the boat to move. Spot-Lock will navigate to maintain the motor on the Spot-Lock location regardless of the position of the boat.

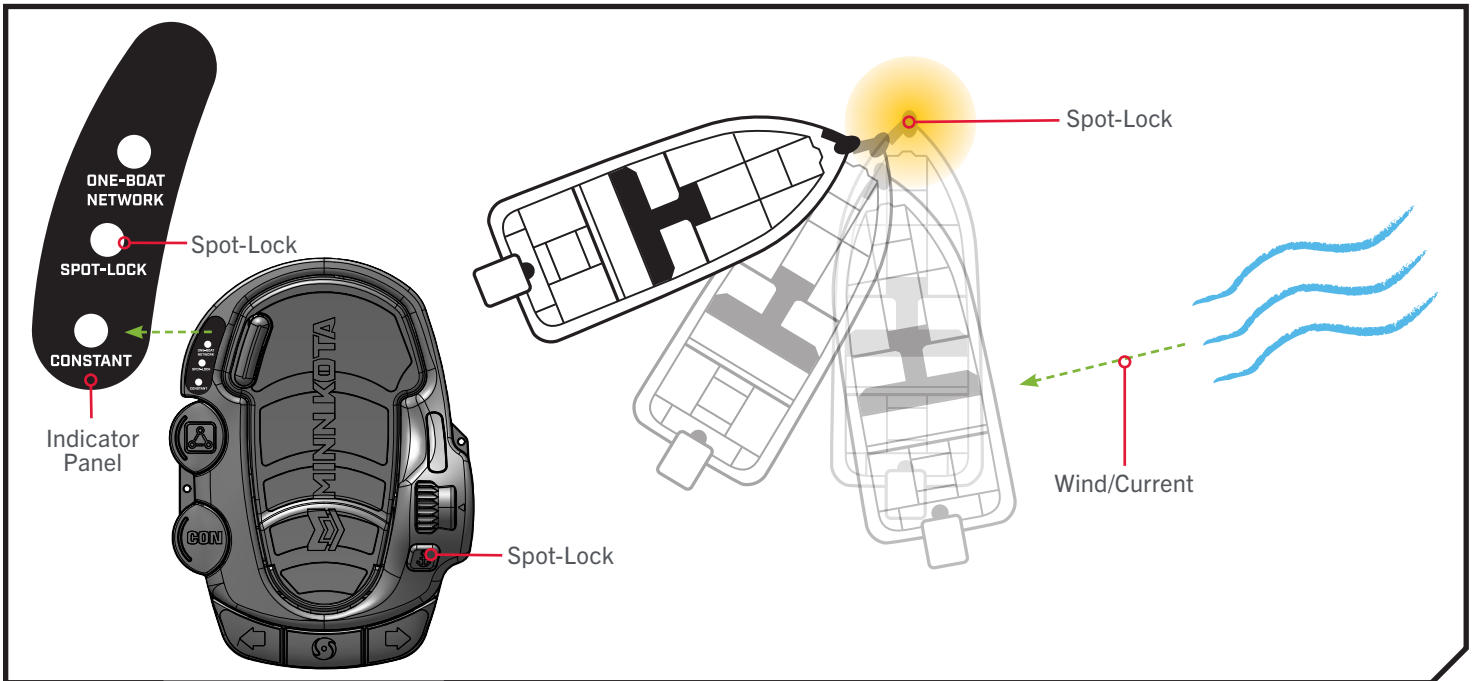

## WARNING

Watch for a turning Prop when working with Spot-Lock. The Prop will automatically turn on when Spot-Lock is engaged, even if the engagement is accidental. A turning Prop can cause injury. The Prop will turn "on" for Spot-Lock, regardless of the Prop Auto On setting used on the other control methods in the Advanced GPS Navigation System.



» Toggle Spot-Lock On/Off

1

- a. While the motor is running, Spot-Lock can be turned on by pressing the Spot-Lock  button located on the Foot Pedal. The yellow SPOT-LOCK  LED on the Indicator Panel is illuminated when Spot-Lock is engaged.

**NOTICE:** In the default Audio Mode, a tone is emitted when Spot-Lock is engaged. If the Audio Mode is set to Alarm Only, a tone will not be emitted when Spot-Lock is engaged. To learn more about Audio Modes, refer to the Wireless Remote owner’s manual.

- b. To disengage Spot-Lock when engaged, press the Spot-Lock button again, or press any button on the Foot Pedal to manually steer the trolling motor.

**NOTICE:** When disengaging Spot-Lock with the Spot-Lock button on the Foot Pedal, no tone will be emitted. Steering the motor with the Foot Pedal or adjusting the speed using the Speed Knob will cancel Spot-Lock, and a High-Low, High-Low, High-Low tone will be emitted.

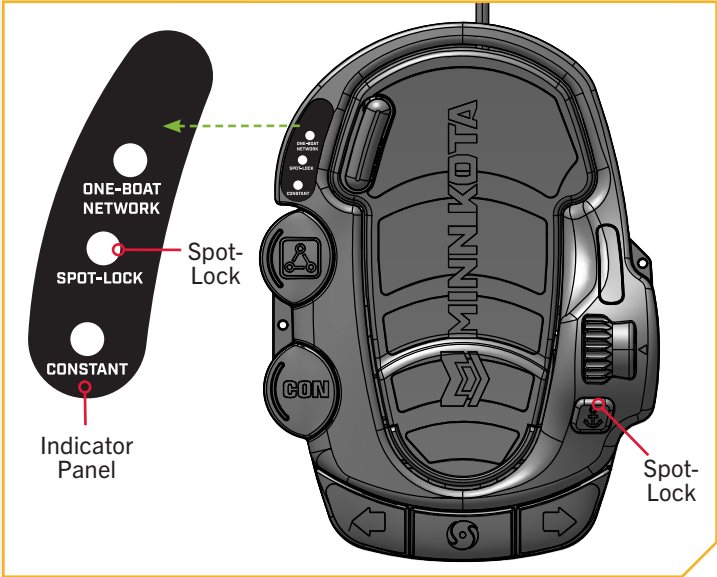

**NOTICE:** Pressing any button on the foot pedal or manually steering the motor with the foot pedal will disengage Spot-Lock. Manually steering or adjusting the Prop Speed with a paired remote will also cancel Spot-Lock.