

## ADVANCED GPS NAVIGATION >

Your Minn Kota trolling motor and Humminbird fish finder communicate with each other to change the way you fish. Advanced GPS Navigation offers a large array of features including controlling speed, steering, Spot-Lock, and the ability to record and retrace paths on the water, all at your fingertips. To learn more about the GPS capabilities available with your new motor, please refer to the Advanced GPS Navigation Owner's Manual by visiting [minnkotamotors.com](http://minnkotamotors.com).

The wireless remote and GPS controller make up the Advanced GPS Navigation system. A wireless remote comes paired to the controller from the factory. The GPS controller contains a very sensitive compass and is where all GPS satellite and remote signals are received. The GPS controller is located in the trolling motor Control Head and may be connected to a fish finder from a connection cable that exits the Control Head. If the Advanced GPS Navigation system will be used with a fish finder, the Ethernet link between the trolling motor and the fish finder should be connected.

## > Considerations for Connecting and Routing Advanced GPS Navigation

If Advanced GPS Navigation is pre-installed on your trolling motor, one eight pin Advanced GPS Ethernet Connector will exit the base of the Control Head and dangle just below the Control Head next to the Coil Cord. If the Advanced GPS Navigation on the trolling motor will be used with a fish finder, an Ethernet Cable will need to be attached to the Advanced GPS Ethernet Connector below the Control Head. Consider the distance between the trolling motor and the fish finder to determine how to complete the Ethernet connection.

**ETHERNET CABLES** - Minn Kota provides one 30 ft Ethernet cable (**AS EC 30E - 30' Ethernet Cable - 720073-4**) with every trolling motor equipped with Advanced GPS Navigation. The 30 ft Ethernet cable will accommodate a standard Ethernet connection for most installations to a Humminbird fish finder and is "Apex and Solix Ready". If the distance between the trolling motor and Humminbird fish finder is relatively small and a shorter cable is preferred, alternate cable lengths are available from [humminbird.com](http://humminbird.com). These options include:

- 10 ft - (**AS EC 10E - 10' Ethernet Cable - 720073-2**)
- 15 ft - (**AS EC 15E - 15' Ethernet Cable - 720073-5**)
- 20 ft - (**AS EC 20E - 20' Ethernet Cable - 720073-3**)

Every length of Ethernet cable plugs directly into a Solix or Apex or directly into a Helix Adapter Cable.

**HUMMINBIRD HELIX ADAPTER CABLES** - Minn Kota provides one Helix Adapter Cable (**AS EC QDE - Ethernet Adapter Cable - 720074-1**) with every trolling motor equipped with Advanced GPS Navigation. If the Ethernet connection is being made between the trolling motor and any Humminbird® Helix fish finder, the Helix Adapter Cable should be used. The Helix Adapter Cable directly connects the Ethernet Cable to a Helix fish finder.

**ETHERNET EXTENSION CABLES** - If the 30 ft Ethernet cable provided with your trolling motor with Advanced GPS Navigation is not long enough to reach the fish finder, an Ethernet Extension cable should be used. The Ethernet Extension cable is available from [humminbird.com](http://humminbird.com) and is available in a 30 ft length (**AS ECX 30E - 30' Ethernet Extension Cable - 760025-1**). The Ethernet Extension Cable will plug directly into any length of Ethernet cable.

**NOTICE:** Minn Kota recommends routing the Ethernet Cable or Ethernet Extension Cable through the Coil Cord when making the Ethernet connection. The cables will be installed from the Mount to the Control Head through the Coil Cord and parallel to any Dual Spectrum CHIRP or Built-in MEGA Down Imaging Cable. Bypassing the Coil Cord when routing the Ethernet Cable or Ethernet Extension Cable is not recommended.

## CAUTION

Failure to follow the recommended wire routing for installed features, if equipped, may cause damage to the product and void your product warranty. Route cables away from pinch points or other areas that may cause them to bend in sharp angles. Routing the cables in any way other than directed may cause damage to the cables by being pinched or severed. Do not over-tighten cable ties as it may damage the wires.

# ADVANCED GPS NAVIGATION

## GPS Ethernet Connection

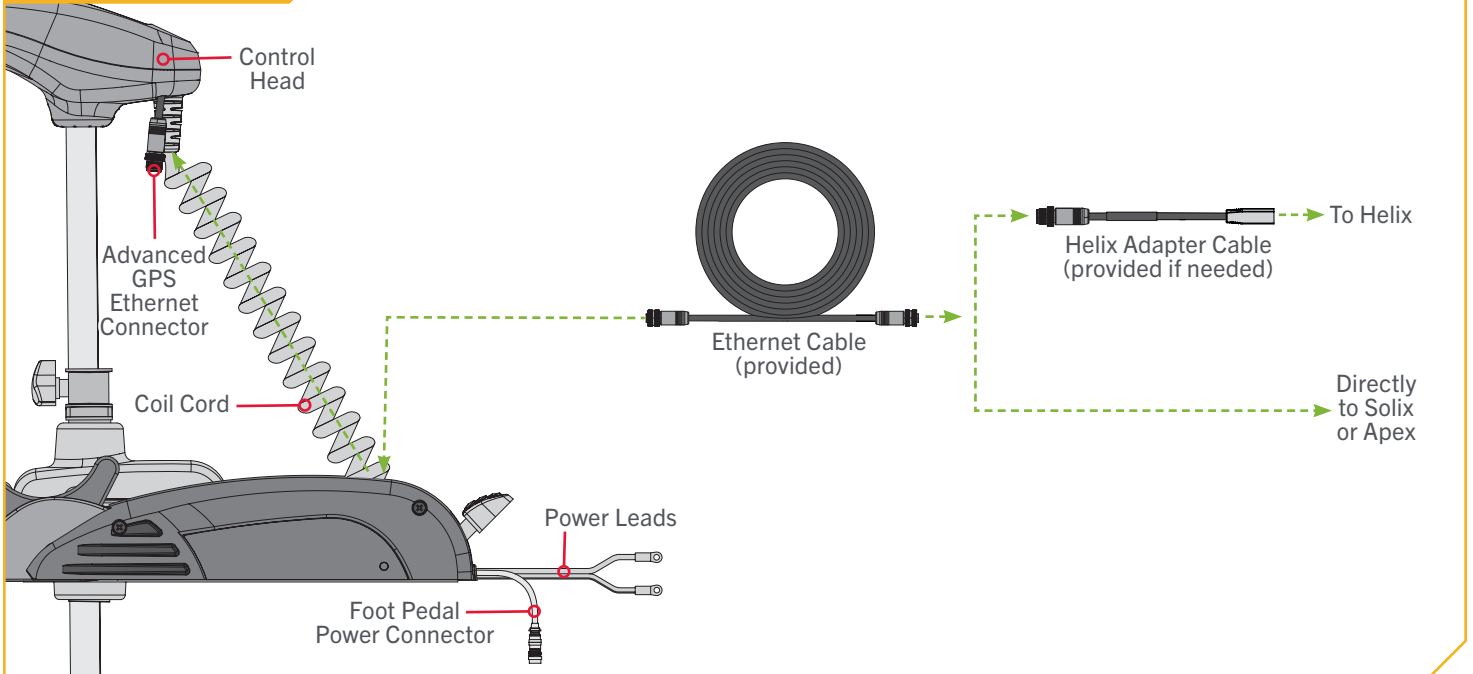

1

**NOTICE:** Your fish finder should be turned off until this procedure is complete.

- a. Place the motor in the deployed position.
- b. Locate the Eight Pin Advanced GPS Ethernet Connector below the Control Head. The Advanced GPS Ethernet Connector will exit the base of the Control Head and will rest just below the Control Head next to the Coil Cord.

**NOTICE:** Terrova trolling motors with Advanced GPS Navigation may also be equipped with Sonar. Sonar is pre-installed from the factory and may be either Dual Spectrum CHIRP or Built-in MEGA Down Imaging. If equipped with Sonar, a Sonar Cable will be present below the control head and run through the middle of the Coil Cord. Review the “Identifying Trolling Motor Features and Their Associated Cables” section of this document to identify and learn more about Sonar.

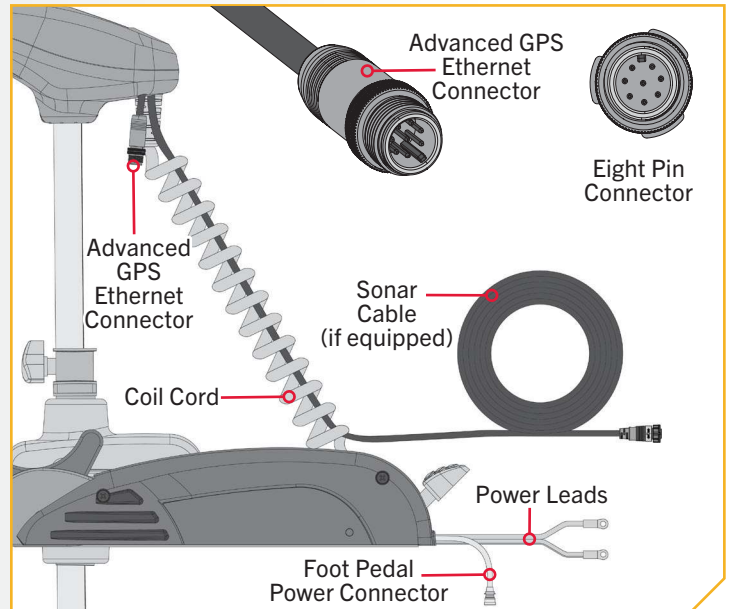

2

ITEM(S) NEEDED

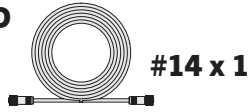

- c. Identify the keyed Receptacle on the Ethernet Cable (Item #14). It will be keyed to fit with the Eight Pin Advanced GPS Ethernet Connector below the Control Head.

**NOTICE:** The Ethernet Cable has a Receptacle for the Advanced GPS Ethernet Connector on both ends and either end may be connected.

**NOTICE:** The 30' Ethernet Cable (AS EC 30E - 30' Ethernet Cable - 720073-4) is provided. If an alternate length is preferred, alternate cable lengths are available from [humminbird.com](http://humminbird.com).

**NOTICE:** A 30' Ethernet Extension Cable (AS ECX 30E - 30' Ethernet Extension Cable - 760025-1) is available from [humminbird.com](http://humminbird.com) and should be used if the standard 30' Ethernet Cable provided with your trolling motor is not long enough to reach the fish finder.

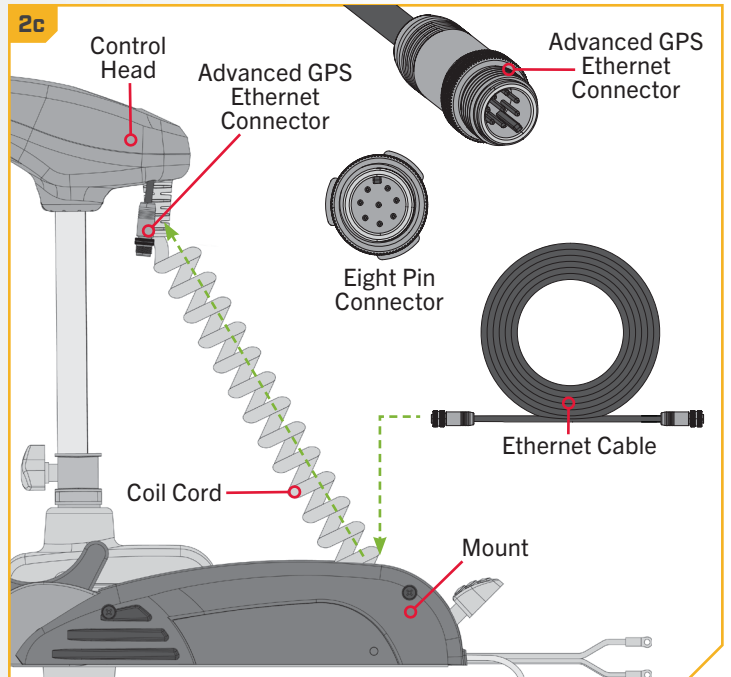

# ADVANCED GPS NAVIGATION

3

- d. If **NO Sonar is present**, take the cable, leading with the Receptacle, and fish it through the center of the Coil Cord starting at the end of the Coil Cord attached to the Mount and working up towards the Control Head. Allow enough slack in the cable to attach the Receptacle to the Advanced GPS Ethernet Connector.

**NOTICE:** Minn Kota recommends routing the Ethernet Cable through the Coil Cord when making the Ethernet connection. The cable will be installed from the Mount to the Control Head through the Coil Cord and parallel to the Advanced GPS Cable. Bypassing the Coil Cord when routing the Ethernet Cable is not recommended.

- e. Verify the length of your motor shaft to determine if Critical Cable Routing applies to your trolling motor. If the trolling motor shaft is 60 inches or more, adjust the Ethernet Cable to exit the Coil Cord three coils before the Motor Base. Review the “Critical Cable Routing” section of this document for more details.

**NOTICE: CRITICAL CABLE ROUTING.** On motors with a shaft 60" or more, accessory cables must exit the Coil Cord leaving three or more open coils between where the cables exit and the motor base, as assembled by the factory. Routing the cables in any other manner will not allow the motor to stow properly. Please see the “Critical Cable Routing” and “Securing Accessory Cables” sections of this document for details.

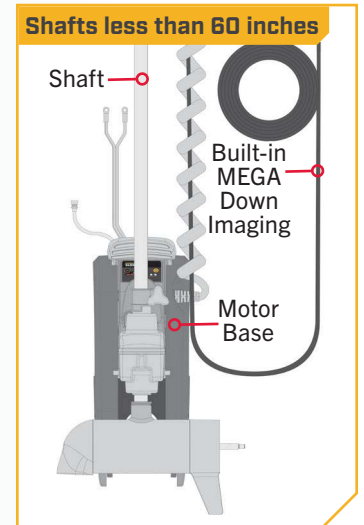
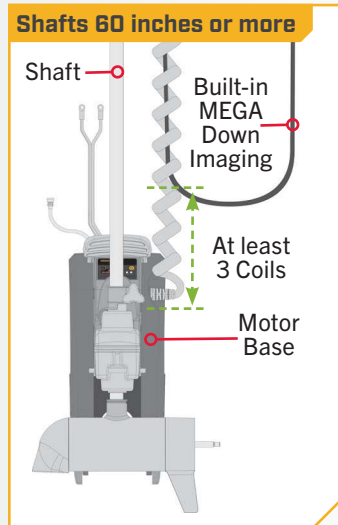
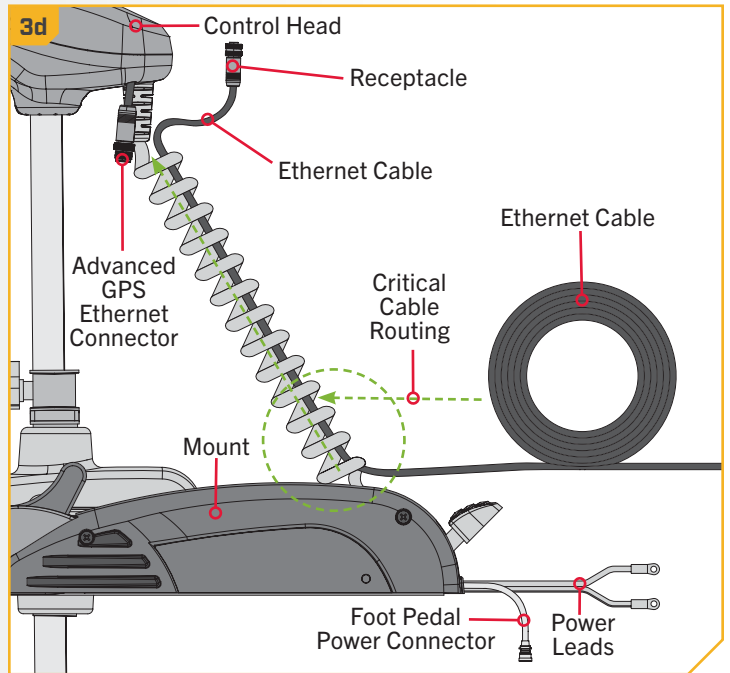

## 4

- f. If Sonar is present, take the Sonar Cable and unwind it from the inside of the Coil Cord, working from the Mount towards the Control Head. Once loose, the Sonar Cable will run parallel to the Coil Cord, but hang freely. Once all cables are connected, the final installation will require for any cables present to be wound back inside the Coil Cord. The final installation will vary based on motor features and shaft length. Please see the “Securing Accessory Cables” section of this document for details once all connections are complete.
- g. Take the Receptacle on the Ethernet Cable and run it parallel to the Sonar Cable. Allow enough slack in the cable to attach the Receptacle to the Advanced GPS Ethernet Connector.

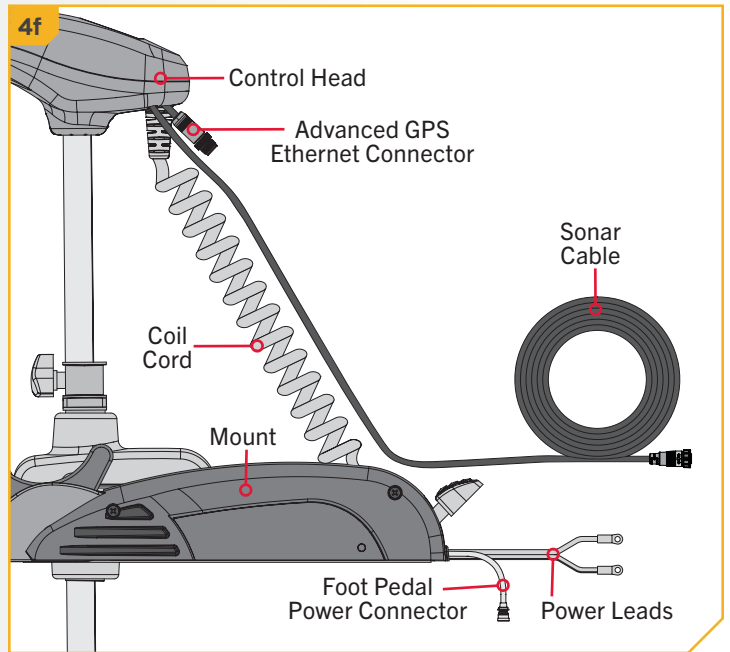

**NOTICE: CRITICAL CABLE ROUTING.** On motors with a shaft 60" or more, accessory cables must exit the Coil Cord leaving three or more open coils between where the cables exit and the motor base, as assembled by the factory. Routing the cables in any other manner will not allow the motor to stow properly. Please see the “Securing Accessory Cables” section of this document for details.

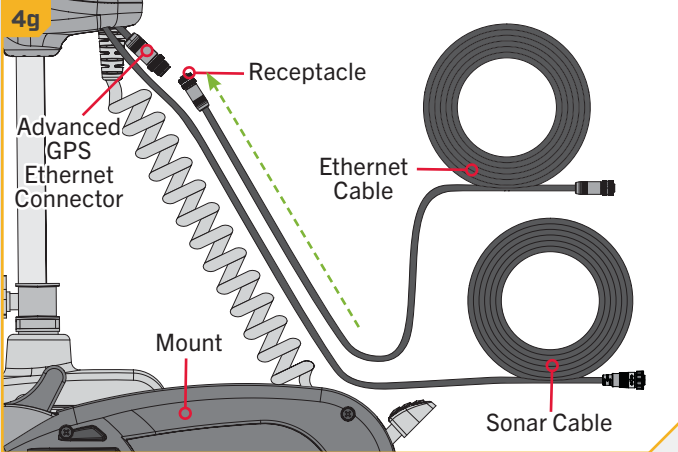

## 5

- h. To install the Ethernet Cable, align the pins on the Advanced GPS Ethernet Connector with the Receptacle on the Ethernet Cable. Notice the keyed connectors. Tighten the Collar from the Ethernet Cable to secure the connection.
- i. The Ethernet Cable will plug directly into a Solix or Helix Fish Finder or directly into a Helix Adapter Cable.

**NOTICE:** The 30' Ethernet Cable (AS EC 30E - 30' Ethernet Cable - 720073-4) is provided. If an alternate length is preferred, alternate cable lengths are available from [humminbird.com](http://humminbird.com).

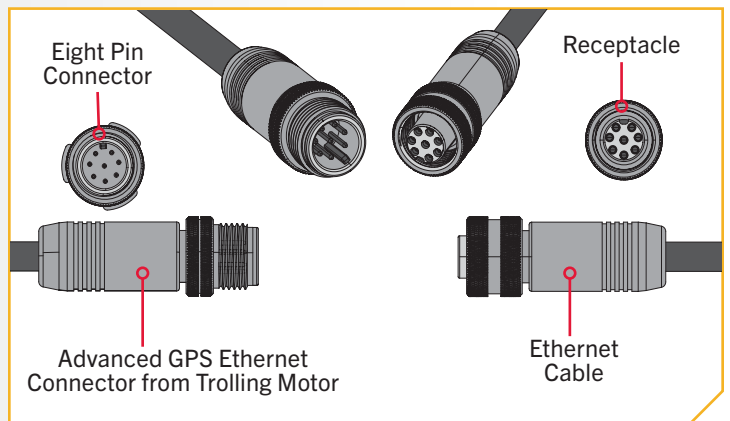

# ADVANCED GPS NAVIGATION

6

- j. If installing directly to a Solix or Apex, the connector will be flat on the back of the fish finder display.
- k. Align the Receptacle on the Ethernet Cable with the Eight Pin Connector on the Apex or Solix fish finder. Notice the keyed connectors. Tighten the Collar from the Ethernet Cable to secure the connection. Once directly installed to the Solix or Apex, the connection is complete.

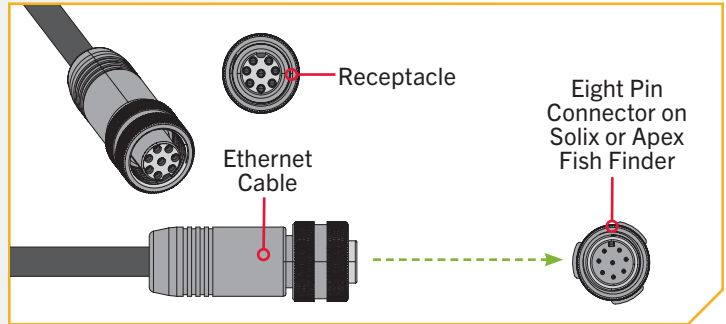

7

## ITEM(S) NEEDED



- l. If installing directly to a Helix Adapter Cable (Item #15), align the Receptacle on the Ethernet Cable with the Eight Pin Connector on the Helix Adapter Cable provided. Notice the keyed connectors. Tighten the Collar from the Ethernet Cable to secure the connection.

**NOTICE:** Minn Kota provides one Helix Adapter Cable (AS EC QDE - Ethernet Adapter Cable - 720074-1) with every trolling motor equipped with Advanced GPS Navigation.

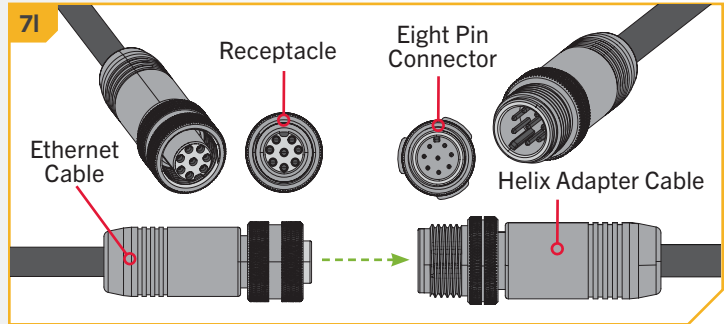

- m. The Helix Adapter Cable directly connects the Ethernet Cable to a Helix fish finder. Locate the Helix Adapter Cable Keyed Connector on the back of the fish finder. Plug the Helix Adapter Cable into the back of the Helix fish finder to complete the connection.
- n. If your trolling motor has more than one feature that requires connection to an output device, complete the connection for that specific output and then follow the instructions for "Securing Accessory Cables" to complete the Accessory Cable installation.

**NOTICE:** If unsure of what features your trolling motor may be installed with that require connection to an output device, please review the "Identifying Trolling Motor Features And Their Associated Cables" section of this manual.

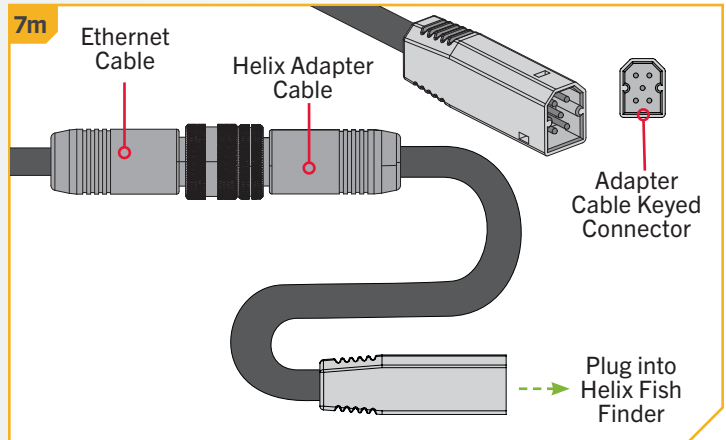

# SECURING ACCESSORY CABLES

## Securing Accessory Cables

Before securing the cables, please review the "Identifying Trolling Motor Features and Their Associated Cables" section of this document. When identifying features, it is very important to secure the cables if **two** connections are present below the Control Head. If only **one** cable is present below the Control Head, securing the Accessory Cables is not necessary. **All cables, regardless of if they need to be secured, need to follow the Critical Cable Routing.** To review, please see the "Critical Cable Routing" section of this document. All Accessory Cables that will be used on the trolling motor must be routed and all connections secured before completing the installation in this section. To review how feature cables should be routed and connected, please review the "Advanced GPS Navigation" and "Dual Spectrum CHIRP" or "Built-in MEGA Down Imaging" sections of this document.

**NOTICE:** If only one cable is present below the Control Head, this installation is not applicable.

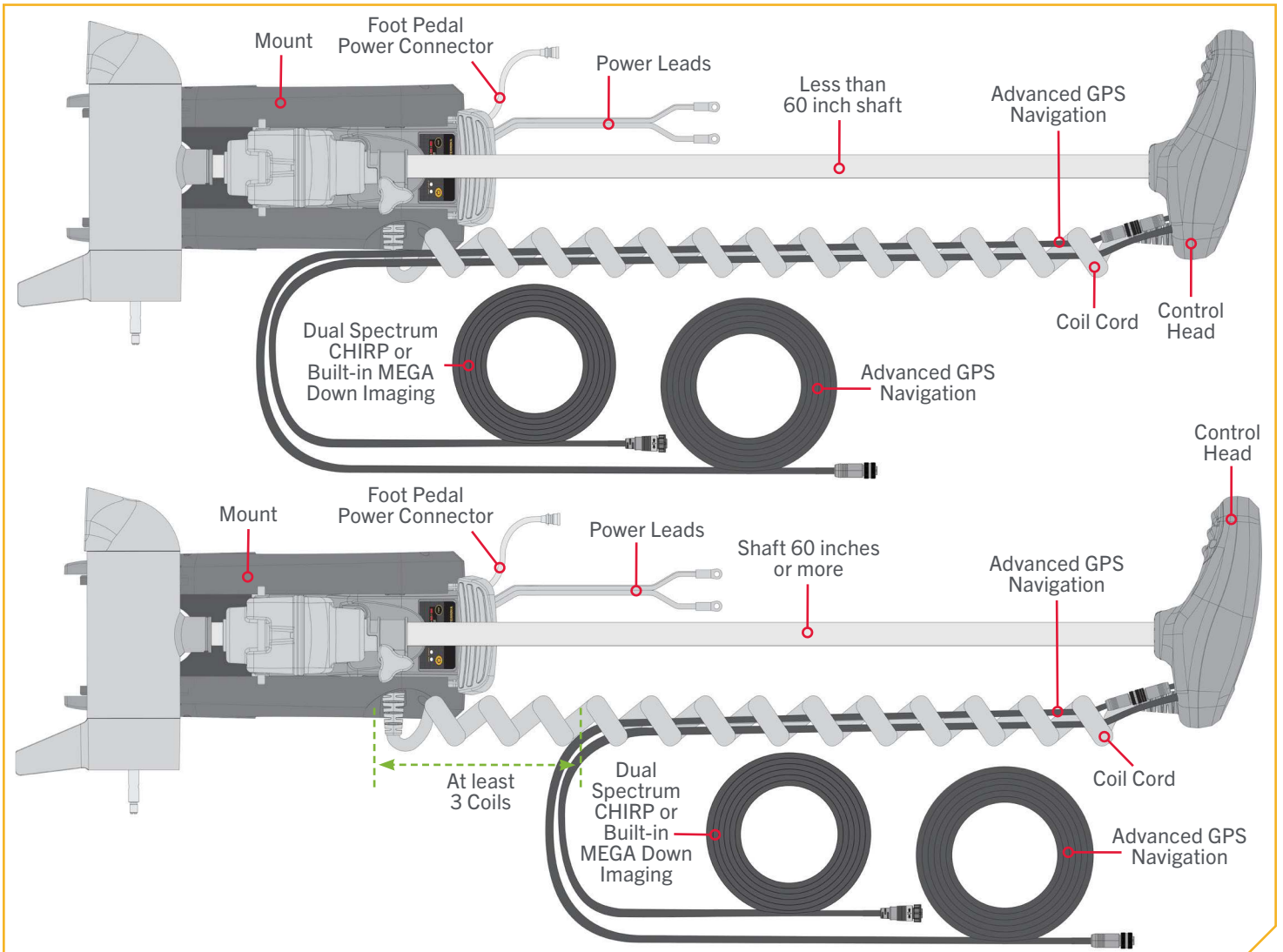

## CAUTION

Failure to follow the recommended wire routing for installed features, if equipped, may cause damage to the product and void your product warranty. Route cables away from pinch points or other areas that may cause them to bend in sharp angles. Routing the cables in any way other than directed may cause damage to the cables by being pinched or severed. Do not over-tighten the cable ties as it may damage the wires.

# SECURING ACCESSORY CABLES

1

- a. Confirm all Accessory Cables are connected to an output device as desired. With the motor in the deployed position, locate the Advanced GPS Ethernet Connector below the Control Head.
- b. Starting just below the Control Head, take both the Accessory Cables and make sure they are free from the Coil Cord and parallel to each other. Run them from the Control Head to the Mount keeping them straight and parallel the entire length.

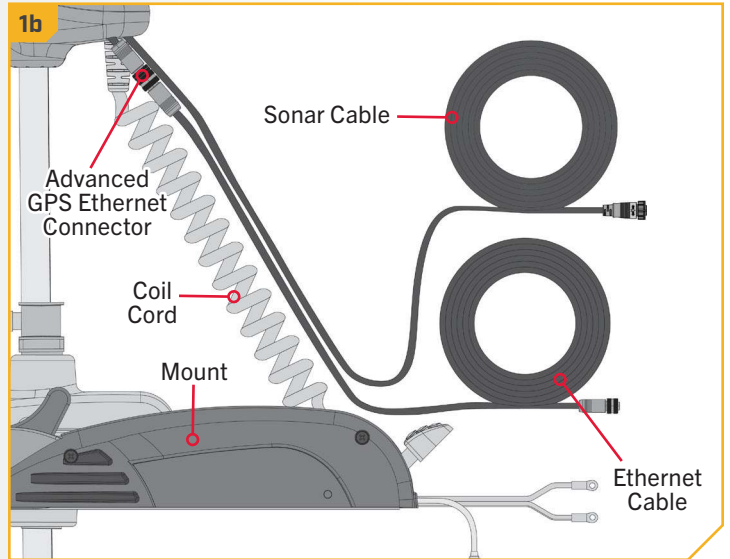

2

## ITEM(S) NEEDED

 #16 x 10

- c. Starting approximately 4 inches below the Control Head, take a Cable Tie (Item #16) and place it around the Accessory Cables. The Cable Tie should be around the Ethernet Cable and Sonar Cable but not the Coil Cord.

**NOTICE:** Do NOT secure the Cables to the Coil Cord. ONLY secure the Cables with the Cable Ties to each other.

- d. Secure the Cable Tie around the Cables until it is fingertip tight. Do not over-tighten the Cable Tie as it will cause damage to the Cables.

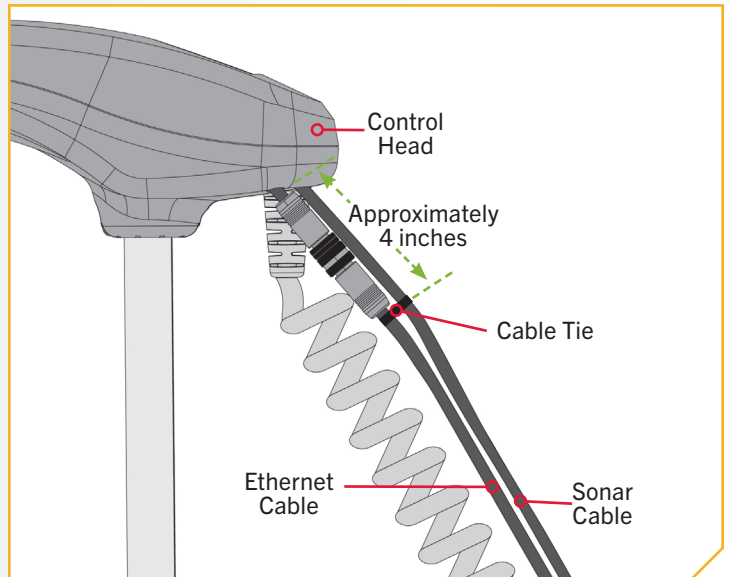

 **CAUTION**

Do not over-tighten the Cable Ties as it may damage the wires.



## SECURING ACCESSORY CABLES

3

- e. Follow the Cables from the Control Head to the Mount and place additional Cable Ties every 4 inches around the Cables after the first Cable Tie. The number of Cable Ties needed will vary depending on the length of your trolling motor Shaft.

**NOTICE:** If additional Cable Ties are needed, a Service Assembly (#2996300 TIE WRAP ASM, 60") is available from the Parts Ordering Portal at [minnkotamotors.com](http://minnkotamotors.com).

**NOTICE:** Secure the Cable Ties fingertip tight. It is recommended to have them **ONLY** tight enough so that they do not slide around on the Connection Cables and hold the cables together.

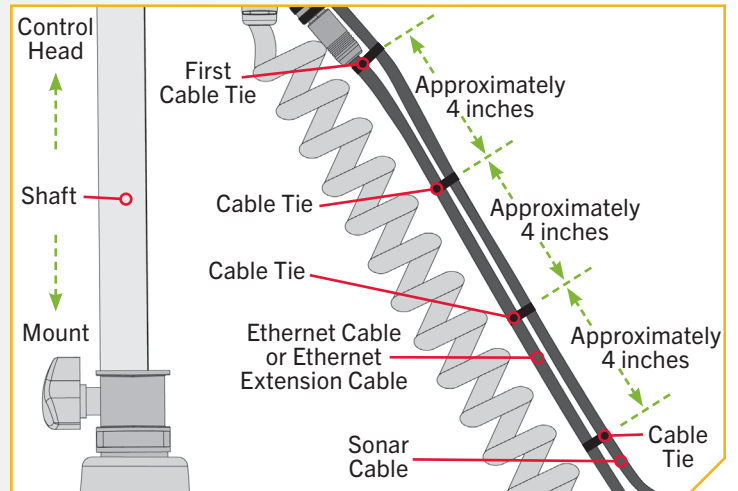

4

- f. Continue placing Cable Ties around the Accessory Cables until there are two Cable Ties in place past the end of where the Coil Cord enters the Mount.

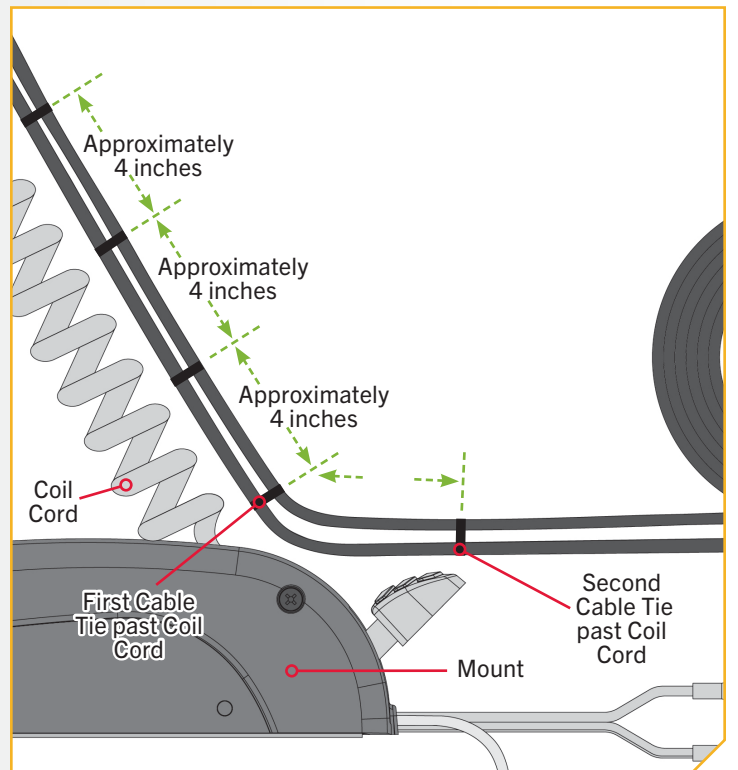

# SECURING ACCESSORY CABLES

5

- g. With the Cable Ties in place, take the Accessory Cables that are tied together and wind them back into the Coil Cord. When successfully placed inside the Coil Cord, they should float freely on the inside of the Coil Cord. To successfully place the Accessory Cables inside the Coil Cord, it may be necessary to temporarily disconnect Accessory Cables that are attached to Extension or Adapter Cables or output devices such as a fish finder.
- h. Place the Motor into the stowed position. Verify the length of your motor shaft to determine if Critical Cable Routing applies to your trolling motor. If the trolling motor shaft is 60 inches or more, adjust the Accessory Cables to exit the Coil Cord three coils before the Motor Base. Review the “Critical Cable Routing” section of this document for more details.

**NOTICE:** Minn Kota recommends routing the Accessory Cables through the Coil Cord. Bypassing the Coil Cord when routing Accessory Cables is not recommended.

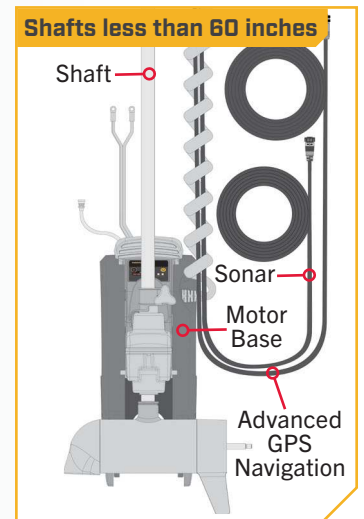
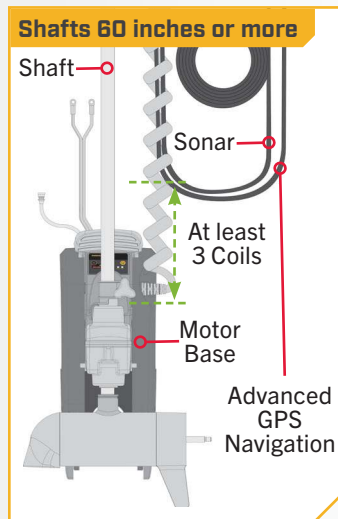
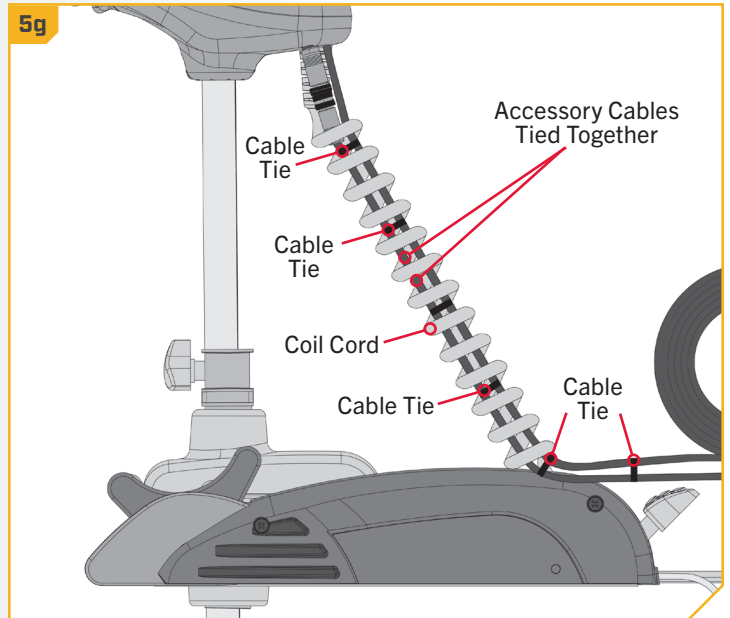

6

- i. Look at the placement of the Cable Ties and make sure that at least 2 Cable Ties are present on the Accessory Cables after they exit the Coil Cord. If additional Cable Ties are needed, it may be necessary to place the motor back into the deployed position to add additional Cable Ties at an increment of approximately 4 inches past the last Cable Tie.
- j. If no additional Cable Ties are needed, make sure to properly reconnect any Accessory Cables that may have been disconnected while winding the Accessory Cables into the Coil Cord.

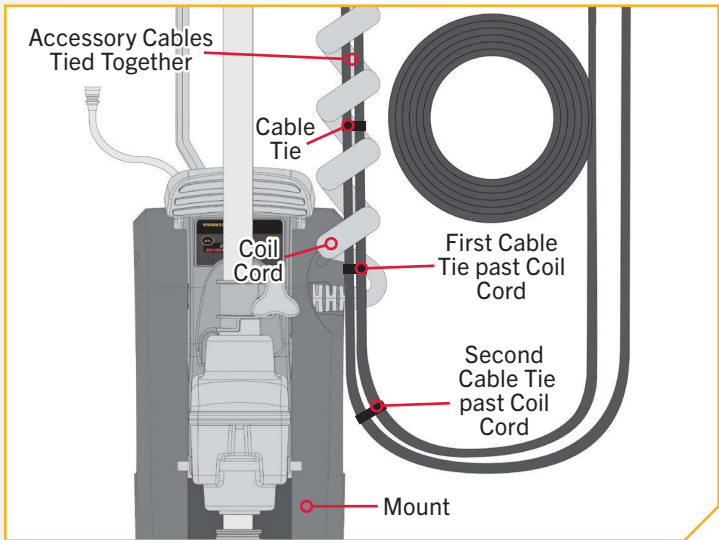

› Installing the Prop

1

**CAUTION**

Disconnect the motor from the battery before beginning any prop work or maintenance.

- a. While holding the Shipping Spacer with a pliers or vise grip, remove the Prop Nut, Red Shipping Washer, Prop Washer and Spacer, being careful not to lose the Drive Pin. Reuse the Prop Nut, Prop Washer and Drive Pin to attach the Propeller.

**NOTICE:** The Shipping Spacer and Red Shipping Washer are for shipping purposes only and must be discarded. The Red Shipping Washer will rust if used to attach the Propeller.

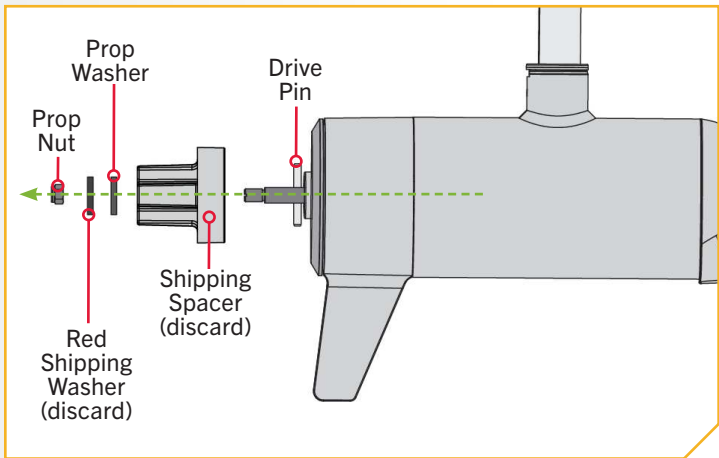

# INSTALLING THE PROP

## 2

### ITEM(S) NEEDED



- b. Take the Drive Pin (Item #9) and slide it through the Hole in the Armature Shaft. Position the Drive Pin horizontally by grasping the Armature Shaft and rotating it with the Drive Pin in place.
- c. Align the Propeller (Item #12) so it is also horizontal and parallel with the Drive Pin. Slide the Propeller onto the Armature Shaft and Drive Pin until it is seated against the lower unit.
- d. Install the Prop Washer (Item #10) and the Prop Nut (Item #11) onto the end of the Armature Shaft.

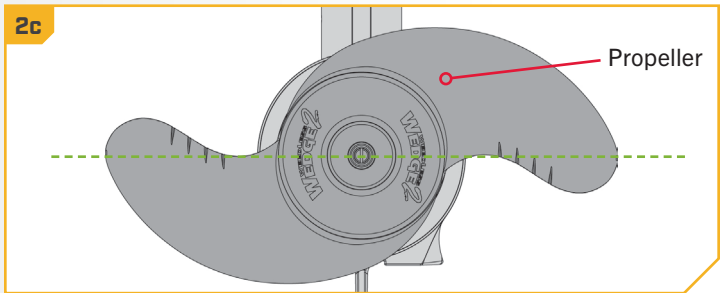
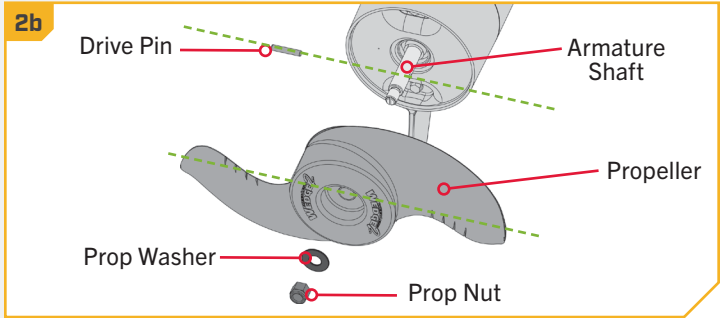

## 3

- e. Holding the end of the Armature Shaft with a Flat Blade Screwdriver, tighten the Prop Nut with a 9/16" Box End or Open End Wrench.
- f. Tighten the Prop Nut 1/4 turn past snug to 25-35 in-lbs.

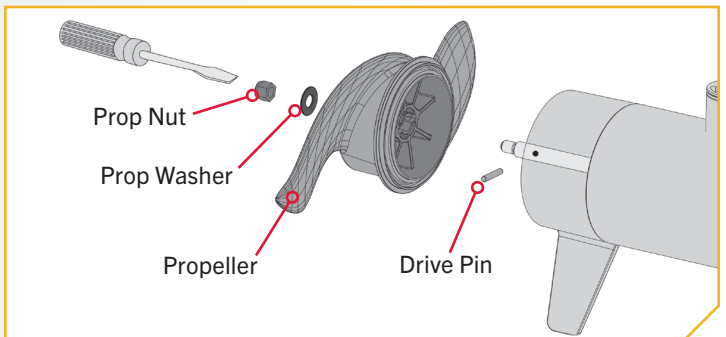

## CAUTION

Do not over-tighten as this can damage the prop.

# BATTERY & WIRING INSTALLATION

## BOAT RIGGING & PRODUCT INSTALLATION

For safety and compliance reasons, we recommend that you follow American Boat and Yacht Council (ABYC) standards when rigging your boat. Altering boat wiring should be completed by a qualified marine technician. The following specifications are for general guidelines only:

### CAUTION

These guidelines apply to general rigging to support your Minn Kota motor. Powering multiple motors or additional electrical devices from the same power circuit may impact the recommended conductor gauge and circuit breaker size. If you are using wire longer than that provided with your unit, follow the conductor gauge and circuit breaker sizing table below. If your wire extension length is more than 25 feet, we recommend that you contact a qualified marine technician.

### CAUTION

**An over-current protection device (circuit breaker or fuse) must be used.** Coast Guard requirements dictate that each ungrounded current-carrying conductor must be protected by a manually reset, trip-free circuit breaker or fuse. The type (voltage and current rating) of the fuse or circuit breaker must be sized accordingly to the trolling motor used. The table below gives recommended guidelines for circuit breaker sizing.

## CONDUCTOR GAUGE AND CIRCUIT BREAKER SIZING TABLE

This conductor and circuit breaker sizing table is only valid for the following assumptions:

1. No more than 2 conductors are bundled together inside of a sheath or conduit outside of engine spaces.
2. Each conductor has 105° C temp rated insulation.
3. No more than 3% voltage drop allowed at full motor power based on published product power requirements.

Motor Thrust / Model	Max Amp Draw	Circuit Breaker		Wire Extension Length				
		Amp	Minimum	5 feet	10 feet	15 feet	20 feet	25 feet
55 lb.	50	50 Amp	12 VDC	8 AWG	4 AWG	2 AWG	2 AWG	1 AWG
80 lb.	56	60 Amp	24 VDC	8 AWG	6 AWG	6 AWG	4 AWG	2 AWG
112 lb.	52	60 Amp	36 VDC	8 AWG	8 AWG	8 AWG	6 AWG	4 AWG

**NOTICE:** Wire Extension Length refers to the distance from the batteries to the trolling motor leads. Consult website for available thrust options. Maximum Amp Draw values only occur intermittently during select conditions and should not be used as continuous amp load ratings.

*Reference*

United States Code of Federal Regulations: 33 CFR 183 – Boats and Associated Equipment ABYC E-11: AC and DC Electrical Systems on Boats

## SELECTING THE CORRECT BATTERIES

### SELECTING THE CORRECT BATTERIES

The motor will operate with any lead-acid, deep-cycle marine 12-volt battery/batteries. For best results, use a deep-cycle, marine battery with at least a 105 amp-hour rating. Maintain battery at full charge. Proper care will ensure having battery power when you need it, and will significantly improve the battery life. Failure to recharge lead-acid batteries (within 12-24 hours) is the leading cause of premature battery failure. Use a multi-stage charger to avoid overcharging. We offer a wide selection of chargers to fit your charging needs. If you are using a crank battery to start a gasoline outboard, we recommend that you use a separate deep-cycle marine battery/batteries for your Minn Kota trolling motor. For more information on battery selection and rigging, please visit [minnkotamotors.com](http://minnkotamotors.com). Minn Kota trolling motors can run on Lithium-Ion batteries. However, they are specifically designed to run on traditional lead acid batteries (flooded, AGM or GEL). Lithium-Ion batteries maintain higher voltages for longer periods of time than lead-acid. Therefore, running a Minn Kota trolling motor at speeds higher than 85% for a prolonged period could cause permanent damage to the motor.

#### **WARNING**

Never connect the (+) and the (-) terminals of the same battery together. Take care that no metal object can fall onto the battery and short the terminals. This would immediately lead to a short and extreme fire danger.

#### **CAUTION**

Refer to “Conductor Gauge and Circuit Breaker Sizing Table” in the previous section to find the appropriate circuit breaker or fuse for your motor. For motors requiring a 60-amp breaker, the Minn Kota MKR-19 60-amp circuit breaker is recommended.

#### **CAUTION**

Please read the following information before connecting your motor to your batteries in order to avoid damaging your motor and/or voiding your warranty.

### ADDITIONAL CONSIDERATIONS

#### › Using Alternator Chargers

Your Minn Kota trolling motor may be designed with an internal bonding wire to reduce sonar interference. Most alternator charging systems do not account for this bonding wire, and connect the negative posts of the trolling motor batteries to the negative posts of the crank/starting battery. These external connections can damage connected electronics and the electrical system of your trolling motor, voiding your warranty. Review your charger’s manual carefully or consult the manufacturer prior to use to ensure your charger is compatible.

Minn Kota recommends using Minn Kota brand chargers to recharge the batteries connected to your Minn Kota trolling motor, as they have been engineered to work with motors that include a bonding wire.



## › Additional Accessories Connected to Trolling Motor Batteries

Significant damage to your Minn Kota motor, your boat electronics, and your boat can occur if incorrect connections are made between your trolling motor batteries and other battery systems. Minn Kota recommends using an exclusive battery system for your trolling motor. Where possible, accessories should be connected to a separate battery system. Radios and sonar units should not be connected to any trolling motor battery systems as interference from the trolling motor is unavoidable. If connecting any additional accessories to any trolling motor battery system, or making connections between the trolling motor batteries and other battery systems on the boat, be sure to carefully observe the information below.

The negative (-) connection must be connected to the negative terminal of the same battery that the trolling motor negative lead connects to. In the diagrams below this battery is labeled “Low Side” Battery. Connecting to any other trolling motor battery will input positive voltage into the “ground” of that accessory, which can cause excess corrosion. Any damage caused by incorrect connections between battery systems will not be covered under warranty.

## › Automatic Jump Start Systems and Selector Switches

Automatic jump start systems and selector switches tie the negatives of the connected batteries together. Connecting these systems to the “High Side” Battery or “Middle” Battery in the diagrams below and will cause significant damage to your trolling motor and electronics. The only trolling motor battery that is safe to connect to one of these systems is the “Low Side” Battery.

**NOTICE:** The internal bonding wire is equipped with a 3-amp fuse. Improper connections described above carrying in excess of 3 amps will blow this fuse and no further damage will be exhibited. If this occurs, RF interference from the trolling motor affecting sonar units and other electronics will be more significant. If the fuse is blown, the wiring error should be found and addressed prior to replacing the fuse. The replacement fuse should be 3 amps or less. An intact fuse does not imply correct rigging; significant damage can be done by incorrect wiring without approaching 3 amps of current.

# CONNECTING THE BATTERIES

## › 12-Volt Systems

1. Make sure that the motor is switched off (speed selector on “OFF” or “0”).
2. Connect positive (+) red lead to positive (+) battery terminal.
3. Connect negative (-) black lead to negative (-) battery terminal.

### **WARNING**

For safety reasons do not switch the motor on until the propeller is in the water. If installing a leadwire plug, observe proper polarity and follow instructions in your boat owner’s manual.



## CONNECTING THE BATTERIES IN SERIES

### CONNECTING THE BATTERIES IN SERIES (IF REQUIRED FOR YOUR MOTOR)

#### 24-Volt Systems

Two 12-volt batteries are required. The batteries must be wired in series, only as directed in the wiring diagram, to provide 24 volts.

1. Make sure that the motor is switched off (speed selector on "0").
2. Connect a connector cable to the positive (+) terminal of battery 1 and to the negative (-) terminal of battery 2.
3. Connect positive (+) red motor lead to positive (+) terminal on battery 2.
4. Connect negative (-) black motor lead to negative (-) terminal of battery 1.

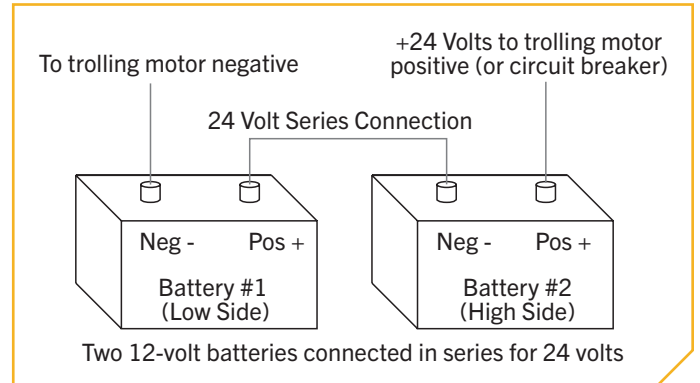

### WARNING

For safety reasons do not switch the motor on until the propeller is in the water. If installing a leadwire plug, observe proper polarity and follow instructions in your boat owner's manual.

### WARNING

- For safety reasons, disconnect the motor from the battery or batteries when the motor is not in use or while the battery/batteries are being charged.
- Improper wiring of 24/36 volt systems could cause battery explosion.
- Keep leadwire wing nut connections tight and solid to battery terminals.
- Locate battery in a ventilated compartment.



# CONNECTING THE BATTERIES IN SERIES

## 36-Volt Systems

Three 12-volt batteries are required. The batteries must be wired in series, only as directed in the wiring diagram, to provide 36 volts.

1. Make sure that the motor is switched off (speed selector on "0").
2. Connect a connector cable to the positive (+) terminal of battery 1 and to the negative (-) terminal of battery 2 and another connector cable from the positive (+) terminal of battery 2 to the negative (-) terminal of battery 3.
3. Connect positive (+) red motor lead to positive (+) terminal on battery 3.
4. Connect negative (-) black motor lead to negative (-) terminal of battery 1.

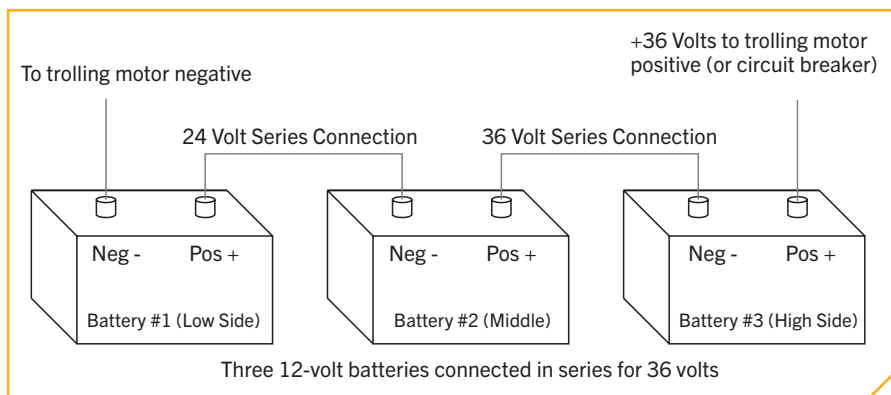

### WARNING

For safety reasons, do not switch the motor on until the propeller is in the water. If installing a leadwire plug, observe proper polarity and follow instructions in your boat owner's manual.

### WARNING

- For safety reasons, disconnect the motor from the battery or batteries when the motor is not in use or while the battery/batteries are being charged.
- Improper wiring of 24/36 volt systems could cause battery explosion.
- Keep leadwire wing nut connections tight and solid to battery terminals.
- Locate battery in a ventilated compartment.