

PARTS DIAGRAM & PARTS LIST

RIPTIDE TRANSOM 80/T - 80 LBS THRUST - 24 VOLT - 42" SHAFT

This page provides Minn Kota® WEEE compliance disassembly instructions. For more information about where you should dispose of your waste equipment for recycling and recovery and/or your European Union member state requirements, please contact your dealer or distributor from which your product was purchased. Tools required, but not limited to: flat head screw driver, Phillips screw driver, socket set, pliers, wire cutters.

› Riptide Transom 80/T Parts Diagram

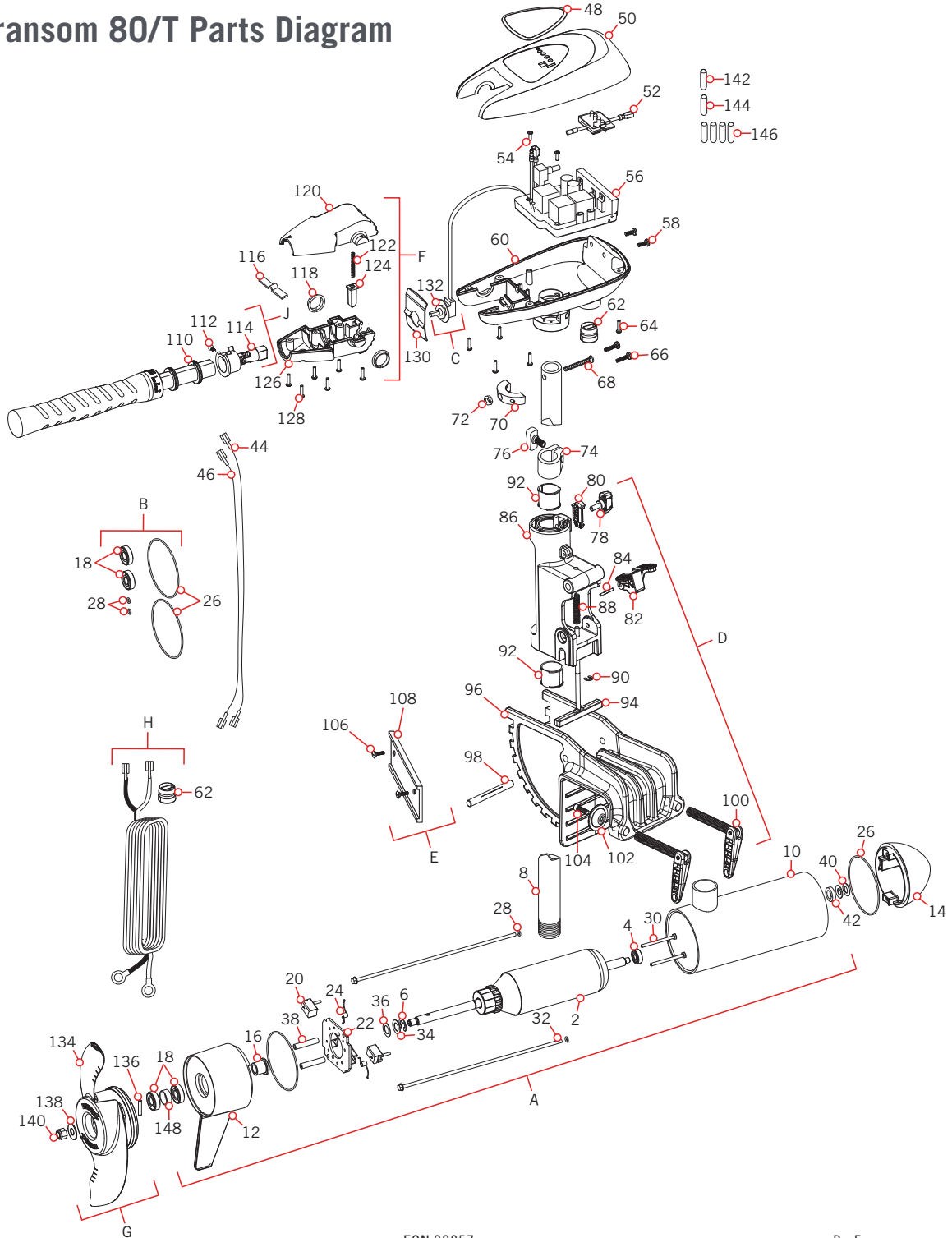

PARTS DIAGRAM & PARTS LIST

› Riptide Transom 80/T Parts List

Assembly	Part #	Description	Quantity
A	2316225	24V MOTOR 42" SW	1
B	2889460	SEAL AND O-RING KIT	1
C	2888411	POTENTIOMETER REPLACEMENT KIT	1
D	2991714	BRACKET ASSY, ALUMINUM	1
E	2994844	BAG ASSEMBLY, TRANSOM EXTRUSION	1
F	2990957	HANDLE ASSY, VARS	1
G	1378132	PROPELLER KIT WW2	1
H	2992523	LEADWIRE ASSY	1
J	2990466	GRIP/HANDLE ASSY, VARS	1
Item	Part #	Description	Quantity
2	2-100-214	ARMATURE ASSEMBLY	1
4	140-010	BEARING	1
6	788-040	RETAINING RING	1
8	2002012	TUBE 42"	1
10	2-200-394	CENTER HOUSING ASSEMBY	1
12	2-300-340	BRUSH END HOUSING ASSEMBLY	1
14	421-376	PLAIN END HOUSING ASSEMBLY STD	1
16	144-017	FLANGE BEARING (SERVICE ONLY)	1
18	880-025	SEAL	2
20	188-094	BRUSH	2
22	738-004	BRUSH PLATE ASSEMBLY	1
24	975-041	BRUSH SPRING	2
26	701-043	O-RING, MOTOR	2
28	701-009	O-RING, THRU-BOLT	2
30	830-027	SCREW, 10-32 X 1/2"	2
32	830-094	THRU-BOLT #12-24 X 10.31	2
34	990-051	WASHER, STEEL	1
36	990-052	WASHER, NYLATRON	1
38	973-025	SPACER, BRUSH PLATE	1
40	992-010	WASHER, BELLEVILLE	2
42	992-045	THRUST SPACER	1
44	640-018	LEADWIRE, BLACK	1
46	640-123	LEADWIRE, RED	1
48	2195667	DECAL, C-BOX COVER	1
50	2060299	C-BOX COVER	1
52	2074081	BATTERY METER, 24V SW	1
54	2043427	SCREW, #8 X 7/8 SS	2
56	2184027	CONTROL BOARD, 24/36V	1
58	2303434	SCREW, #8-32 X 5/8 SS	2
60	2062538	CONTROL BOX, CAST, SW	1
62	2062905	STRAIN RELIEF	1
64	2303412	SCREW, #6-20 X 5/8 SS	6
66	2063410	SCREW, #10-32 X 3/4" CAP SS	2
68	2093400	SCREW, #10-24 X 1-7/8" PPH SS	1

Item	Part #	Description	Quantity
70	2061529	COLLAR-CTRL BOX (SW)	1
72	2333101	NUT, #10-24, NYLOCK, SS	1
74	2031520	COLLAR-DEPTH (W/O INSERT)	1
76	2011366	SCREW-COLLAR/NEW KNOB (SS)	1
78	2011366	KNOB, SCREW-COLLAR, SS	1
80	2062801	TENSION BLOCK	1
82	2077202	LEVER-TILT, TRANSOM BRACKET	1
84	2070512	PIN-HINGE, 1/8 X 1	1
86	2071863	HINGE-SW	1
88	2332700	SPRING-(T-BAR), SS	1
90	2333001	E-RING, SS	1
92	2037301	BUSHING, HINGE	2
94	2073604	T-BAR, (E-COAT)	1
96	2071947	BRACKET, SAND CAST SW	1
98	2070514	PIN-HINGE, 3/8 X 3.5, SS	1
100	2991303	CLAMP SCREW, HANDLE ASSY.	2
102	2331700	WASHER-CLAMP SCREW, SS	2
104	2263452	SCREW, 1/4-20 X 3/4 SHCS, SS	2
106	2053421	SCREW 1/4-14 X 1 PFH, SS	2
108	2058415	TRANSOM EXTRUSION	1
110	2060015	BEARING, HANDLE	2
112	2063405	SCREW, #6 PFH SS	2
114	2884092	YOKE / SPIDER ASSY, VARS	1
116	2302742	SPRING, DETENT, OFF	1
118	2060005	BEARING, HANDLE PIVOT	2
120	2060900	HANDLE PIVOT, TOP	1
122	2302745	SPRING, RELEASE BUTTON	1
124	2063700	BUTTON, RELEASE	1
126	2060905	HANDLE PIVOT, BOTTOM	1
128	2303412	SCREW, #6-20 X 5/8 SS	6
130	2062715	SPRING, HANDLE PIVOT	1
132	2061700	WASHER, POT HOLDER	1
134	2331160	PROPELLER WW2	1
136	2262658	DRIVE PIN, LARGE	1
138	2091701	WASHER, PROP, LARGE	1
140	2198401	NUT, NYLOCK, PROP, ANODE	1
142	2305415	SHRINK TUBE	1
144	2305410	SHRINK TUBE	1
146	2305403	SHRINK TUBE	4
148	725-095	PAPER TUBE-SEAL BORE	1

✘ This part is included in an assembly and cannot be ordered individually.

▲ Not shown on Parts Diagram.