

EM Riptide 55
12 Volt 50 AMPS

for use with "Q" serial numbers
2-year warranty

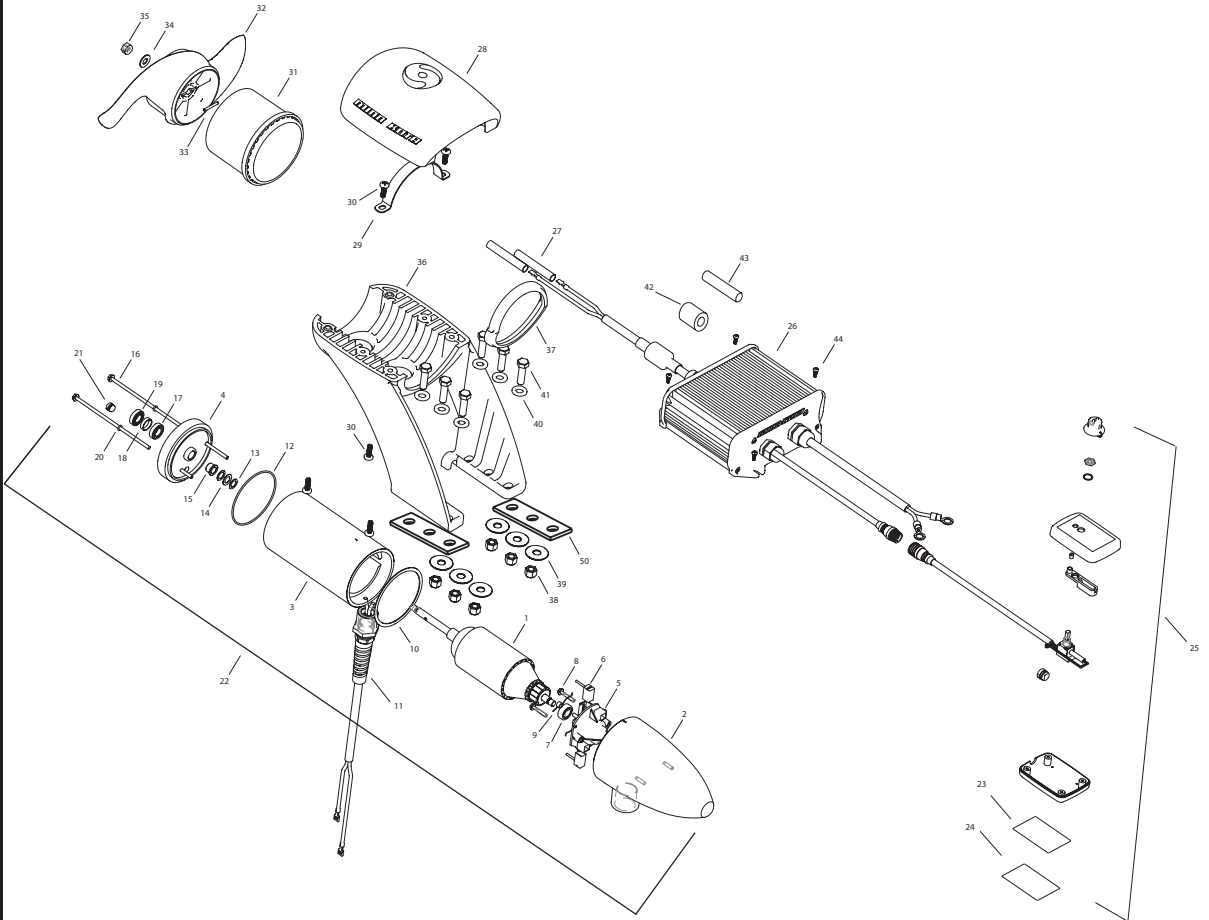

1	2-100-207	ARMATURE 12V 3.62
2	421-302	BRUSH END HOUSING
3	2-200-301	CENTER HOUSING ASSEMBLY
4	2-400-338	PLAIN END ASSY (CONTAINS 4, 15, 17, 18, 19.)
5	2-600-168	BRUSH PLATE ASSEMBLY (CONTAINS 5, 6, 9, 18)
6	188-036	BRUSH
7	140-010	BEARING
8	830-007	SCREW #8-32
9	975-040	BRUSH SPRING
10	337-036	GASKET
11	2772917	LEADWIRE ASSEMBLY
12	701-081	O-RING
13	990-067	WASHER STEEL
14	990-070	WASHER NYLATRON
15	144-049	FLANGE BEARING
16	830-042	THRU-BOLT 10-32 X 8.83
17	880-003	SEAL
18	725-035	PAPER TUBE
19	880-006	SEAL WITH SHIELD
20	701-008	O-RING THRUBOLT
21	836-001	ALUMINUM PLUG
22	2387103	MOTOR ASSY 12V 3.625 55#
23	9950953	VELCRO 1.5 X 2.0 LOOP
24	9950950	VELCRO 1.5 X 2.0 HOOK
25	2990241	HAND CONTROLLER
26	2990246	CONTROL MODULE
27	2385401	SHRINK TUBE [4 EA]
28	2380211	TOP CAP
29	2383810	STRAP, EM
30	2383418	SCREW 1/4-20 SELF TAPPING [6 EA]
31	2381535	ADAPTER RING, REAR
■	1378170	PROP KIT
32	2091170	PROPELLER
33	2092600	DRIVE PIN
34	2151726	WASHER 5/16, PROP
35	2198400	NUT, PROP ANODE
36	2381940	LOWER BRACKET
37	2381530	ADAPTER RING, FRONT
38	2383122	NUT 3/8-16 NYLOCK [6EA]
39	2381726	WASHER FENDER 3/8 X 1 1/4 OD [6 EA]
40	2381728	WASHER 3/8 [6 EA]
41	2383422	SCREW 3/8 X 1 1/4 [6EA]
42	2307310	FERRITE BEAD (EUROPEAN MOTORS ONLY)
43	2075401	HEATSHRINK (EUROPEAN MOTORS ONLY)
44	2373427	SCREW #12 X 5/8 [4 EA]
50	2385110	INSULATOR PAD, EM
■	2994856	BAG ASSY (CONTAINS 38-41,27,23,24,44, 50, & TIE WRAPS)

* This item is part of an assembly. This item cannot be sold separately due to machining and /or assembly that is required.

