

› Installing the Prop

1

**⚠ CAUTION**

Disconnect the motor from the battery before beginning any prop work or maintenance.

- a. While holding the Shipping Spacer with a pliers or vise grip, remove the Prop Nut, Red Shipping Washer, Prop Washer and Spacer, being careful not to lose the Drive Pin. Reuse the Prop Nut, Prop Washer and Drive Pin to attach the Propeller.

**NOTICE:** The Shipping Spacer and Red Shipping Washer are for shipping purposes only and must be discarded. The Red Shipping Washer will rust if used to attach the Propeller.

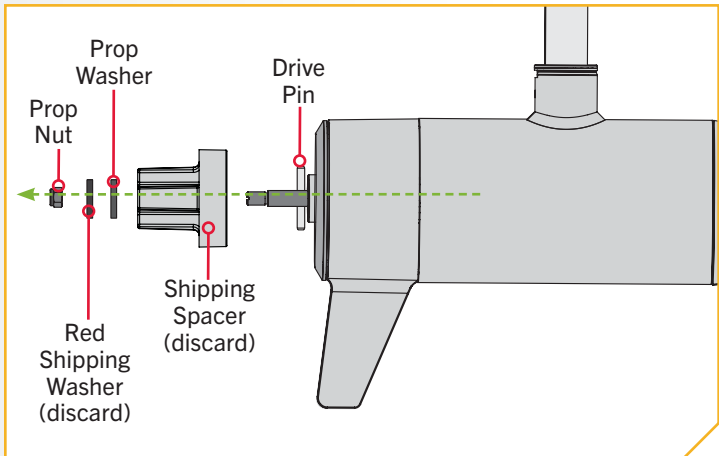

2

ITEM(S) NEEDED



- b. Take the Drive Pin (Item #8) and slide it through the Hole in the Armature Shaft. Position the Drive Pin horizontally by grasping the Armature Shaft and rotating it with the Drive Pin in place.
- c. Align the Propeller (Item #11) so it is also horizontal and parallel with the Drive Pin. Slide the Propeller onto the Armature Shaft and Drive Pin until it is seated against the lower unit.
- d. Install the Prop Washer (Item #9) and the Prop Nut (Item #10) onto the end of the Armature Shaft.

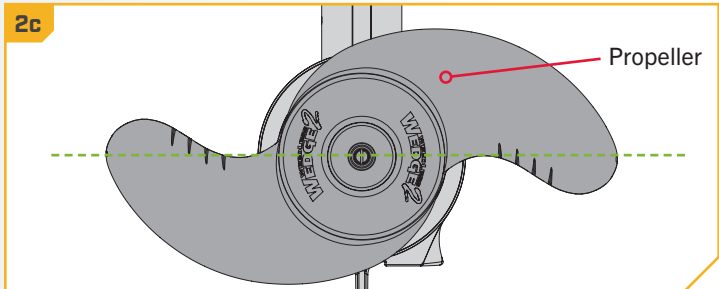
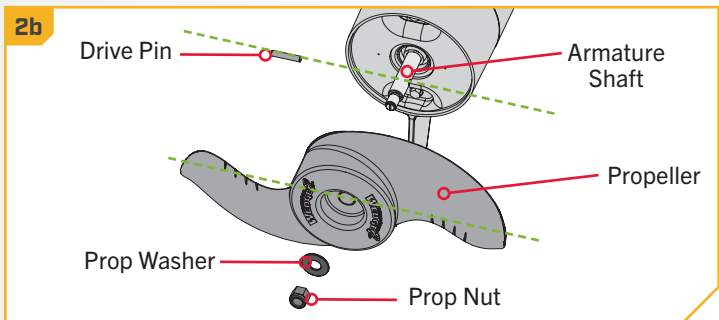

## INSTALLING THE PROP

3

- e. Holding the end of the Armature Shaft with a Flat Blade Screwdriver, tighten the Prop Nut with a 9/16" Box End or Open End Wrench.
- f. Tighten the Prop Nut 1/4 turn past snug to 25-35 in-lbs.



### CAUTION

Do not over tighten as this can damage the prop.

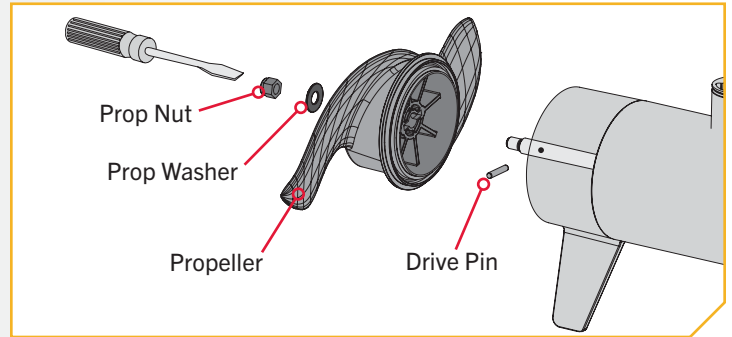

# BATTERY & WIRING INSTALLATION

## BOAT RIGGING & PRODUCT INSTALLATION

For safety and compliance reasons, we recommend that you follow American Boat and Yacht Council (ABYC) standards when rigging your boat. Altering boat wiring should be completed by a qualified marine technician. The following specifications are for general guidelines only:

### CAUTION

These guidelines apply to general rigging to support your Minn Kota motor. Powering multiple motors or additional electrical devices from the same power circuit may impact the recommended conductor gauge and circuit breaker size. If you are using wire longer than that provided with your unit, follow the conductor gauge and circuit breaker sizing table below. If your wire extension length is more than 25 feet, we recommend that you contact a qualified marine technician.

### CAUTION

**An over-current protection device (circuit breaker or fuse) must be used.** Coast Guard requirements dictate that each ungrounded current-carrying conductor must be protected by a manually reset, trip-free circuit breaker or fuse. The type (voltage and current rating) of the fuse or circuit breaker must be sized accordingly to the trolling motor used. The table below gives recommended guidelines for circuit breaker sizing.

## CONDUCTOR GAUGE AND CIRCUIT BREAKER SIZING TABLE

This conductor and circuit breaker sizing table is only valid for the following assumptions:

1. No more than 2 conductors are bundled together inside of a sheath or conduit outside of engine spaces.
2. Each conductor has 105° C temp rated insulation.
3. No more than 3% voltage drop allowed at full motor power based on published product power requirements.

Motor Thrust / Model	Max Amp Draw	Circuit Breaker		Wire Extension Length				
		Amp	Minimum	5 feet	10 feet	15 feet	20 feet	25 feet
55 lb.	50	50 Amp	12 VDC	8 AWG	4 AWG	2 AWG	2 AWG	1 AWG
80 lb.	56	60 Amp	24 VDC	8 AWG	6 AWG	6 AWG	4 AWG	2 AWG
112 lb.	52	60 Amp	36 VDC	8 AWG	8 AWG	8 AWG	6 AWG	4 AWG

**NOTICE:** Wire Extension Length refers to the distance from the batteries to the trolling motor leads. Consult website for available thrust options. Maximum Amp Draw values only occur intermittently during select conditions and should not be used as continuous amp load ratings.

#### Reference

United States Code of Federal Regulations: 33 CFR 183 – Boats and Associated Equipment ABYC E-11: AC and DC Electrical Systems on Boats

## SELECTING THE CORRECT BATTERIES



### SELECTING THE CORRECT BATTERIES

The motor will operate with any lead-acid, deep-cycle marine 12-volt battery/batteries. For best results, use a deep-cycle, marine battery with at least a 105 amp-hour rating. Maintain battery at full charge. Proper care will ensure having battery power when you need it, and will significantly improve the battery life. Failure to recharge lead-acid batteries (within 12-24 hours) is the leading cause of premature battery failure. Use a multi-stage charger to avoid overcharging. We offer a wide selection of chargers to fit your charging needs. If you are using a crank battery to start a gasoline outboard, we recommend that you use a separate deep cycle marine battery/batteries for your Minn Kota trolling motor. For more information on battery selection and rigging, please visit [minnkotamotors.com](http://minnkotamotors.com). Minn Kota trolling motors can run on Lithium-Ion batteries. However, they are specifically designed to run on traditional lead-acid batteries (flooded, AGM or GEL). Lithium-Ion batteries maintain higher voltages for longer periods of time than lead-acid. Therefore, running a Minn Kota trolling motor at speeds higher than 85% for a prolonged period could cause permanent damage to the motor.

#### **WARNING**

Never connect the (+) and the (-) terminals of the same battery together. Take care that no metal object can fall onto the battery and short the terminals. This would immediately lead to a short and extreme fire danger.

#### **CAUTION**

Refer to “Conductor Gauge and Circuit Breaker Sizing Table” in the previous section to find the appropriate circuit breaker or fuse for your motor. For motors requiring a 60-amp breaker, the Minn Kota MKR-19 60-amp circuit breaker is recommended.

#### **CAUTION**

Please read the following information before connecting your motor to your batteries in order to avoid damaging your motor and/or voiding your warranty.

### ADDITIONAL CONSIDERATIONS

#### › Using DC or Alternator Chargers

Your Minn Kota trolling motor may be designed with an internal bonding wire to reduce sonar interference. Most alternator charging systems do not account for this bonding wire, and connect the negative posts of the trolling motor batteries to the negative posts of the crank/starting battery. These external connections can damage connected electronics and the electrical system of your trolling motor, voiding your warranty. Review your charger’s manual carefully or consult the manufacturer prior to use to ensure your charger is compatible.

Minn Kota recommends using Minn Kota brand chargers to recharge the batteries connected to your Minn Kota trolling motor, as they have been engineered to work with motors that include a bonding wire.





## › Additional Accessories Connected to Trolling Motor Batteries

Significant damage to your Minn Kota motor, your boat electronics, and your boat can occur if incorrect connections are made between your trolling motor batteries and other battery systems. Minn Kota recommends using an exclusive battery system for your trolling motor. Where possible, accessories should be connected to a separate battery system. Radios and sonar units should not be connected to any trolling motor battery systems as interference from the trolling motor is unavoidable. If connecting any additional accessories to any trolling motor battery system, or making connections between the trolling motor batteries and other battery systems on the boat, be sure to carefully observe the information below.

The negative (-) connection must be connected to the negative terminal of the same battery that the trolling motor negative lead connects to. In the diagrams below this battery is labeled “Low Side” Battery. Connecting to any other trolling motor battery will input positive voltage into the “ground” of that accessory, which can cause excess corrosion. Any damage caused by incorrect connections between battery systems will not be covered under warranty.

## › Automatic Jump Start Systems and Selector Switches

Automatic jump start systems and selector switches tie the negatives of the connected batteries together. Connecting these systems to the “High Side” Battery or “Middle” Battery in the diagrams below and will cause significant damage to your trolling motor and electronics. The only trolling motor battery that is safe to connect to one of these systems is the “Low Side” Battery.

# CONNECTING THE BATTERIES

## › 12-Volt Systems

1. Make sure that the motor is switched off (speed selector on “OFF” or “0”).
2. Connect positive (+) red lead to positive (+) battery terminal.
3. Connect negative (–) black lead to negative (–) battery terminal.

# WARNING

For safety reasons do not switch the motor on until the propeller is in the water. If installing a leadwire plug, observe proper polarity and follow instructions in your boat owner’s manual.



# CONNECTING THE BATTERIES IN SERIES

## CONNECTING THE BATTERIES IN SERIES (IF REQUIRED FOR YOUR MOTOR)

### 24-Volt Systems

Two 12-volt batteries are required. The batteries must be wired in series, only as directed in the wiring diagram, to provide 24 volts.

1. Make sure that the motor is switched off (speed selector on “0”).
2. Connect a connector cable to the positive (+) terminal of battery 1 and to the negative (-) terminal of battery 2.
3. Connect positive (+) red motor lead to positive (+) terminal on battery 2.
4. Connect negative (-) black motor lead to negative (-) terminal of battery 1.

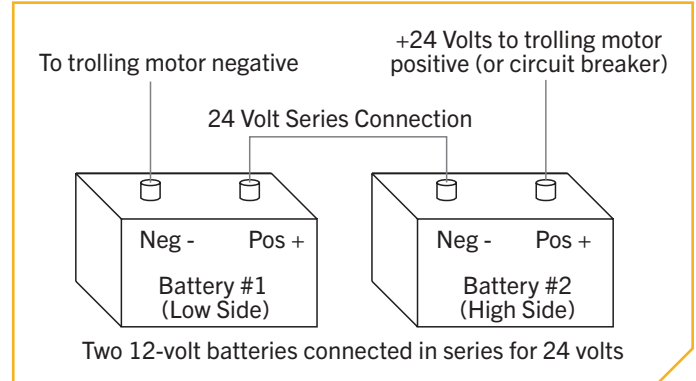

## WARNING

For safety reasons do not switch the motor on until the propeller is in the water. If installing a leadwire plug, observe proper polarity and follow instructions in your boat owner’s manual.

## WARNING

- For safety reasons, disconnect the motor from the battery or batteries when the motor is not in use or while the battery/batteries are being charged.
- Improper wiring of 24/36 volt systems could cause battery explosion.
- Keep leadwire wing nut connections tight and solid to battery terminals.
- Locate battery in a ventilated compartment.

# CONNECTING THE BATTERIES IN SERIES

## 36-Volt Systems

Three 12-volt batteries are required. The batteries must be wired in series, only as directed in the wiring diagram, to provide 36 volts.

1. Make sure that the motor is switched off (speed selector on "0").
2. Connect a connector cable to the positive (+) terminal of battery 1 and to the negative (-) terminal of battery 2 and another connector cable from the positive (+) terminal of battery 2 to the negative (-) terminal of battery 3.
3. Connect positive (+) red motor lead to positive (+) terminal on battery 3.
4. Connect negative (-) black motor lead to negative (-) terminal of battery 1.

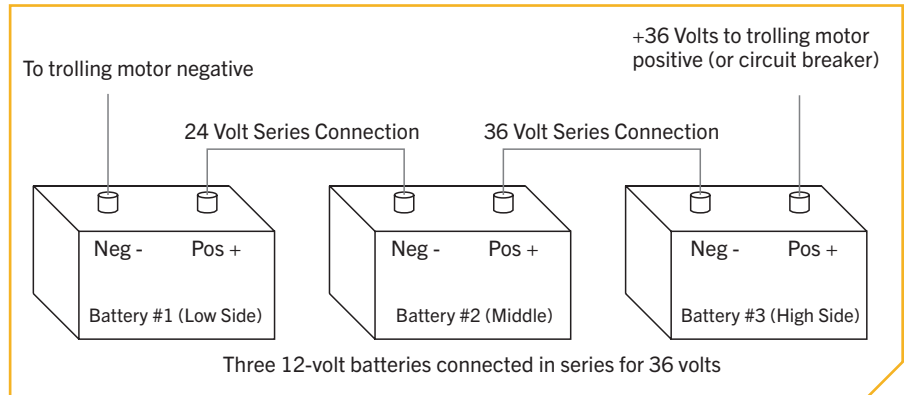

### WARNING

For safety reasons, do not switch the motor on until the propeller is in the water. If installing a leadwire plug, observe proper polarity and follow instructions in your boat owner's manual.

### WARNING

- For safety reasons, disconnect the motor from the battery or batteries when the motor is not in use or while the battery/batteries are being charged.
- Improper wiring of 24/36 volt systems could cause battery explosion.
- Keep leadwire wing nut connections tight and solid to battery terminals.
- Locate battery in a ventilated compartment.

# MOTOR WIRING DIAGRAM

## RIPTIDE TERROVA

The following Motor Wiring Diagram applies to all Riptide Terrova models.

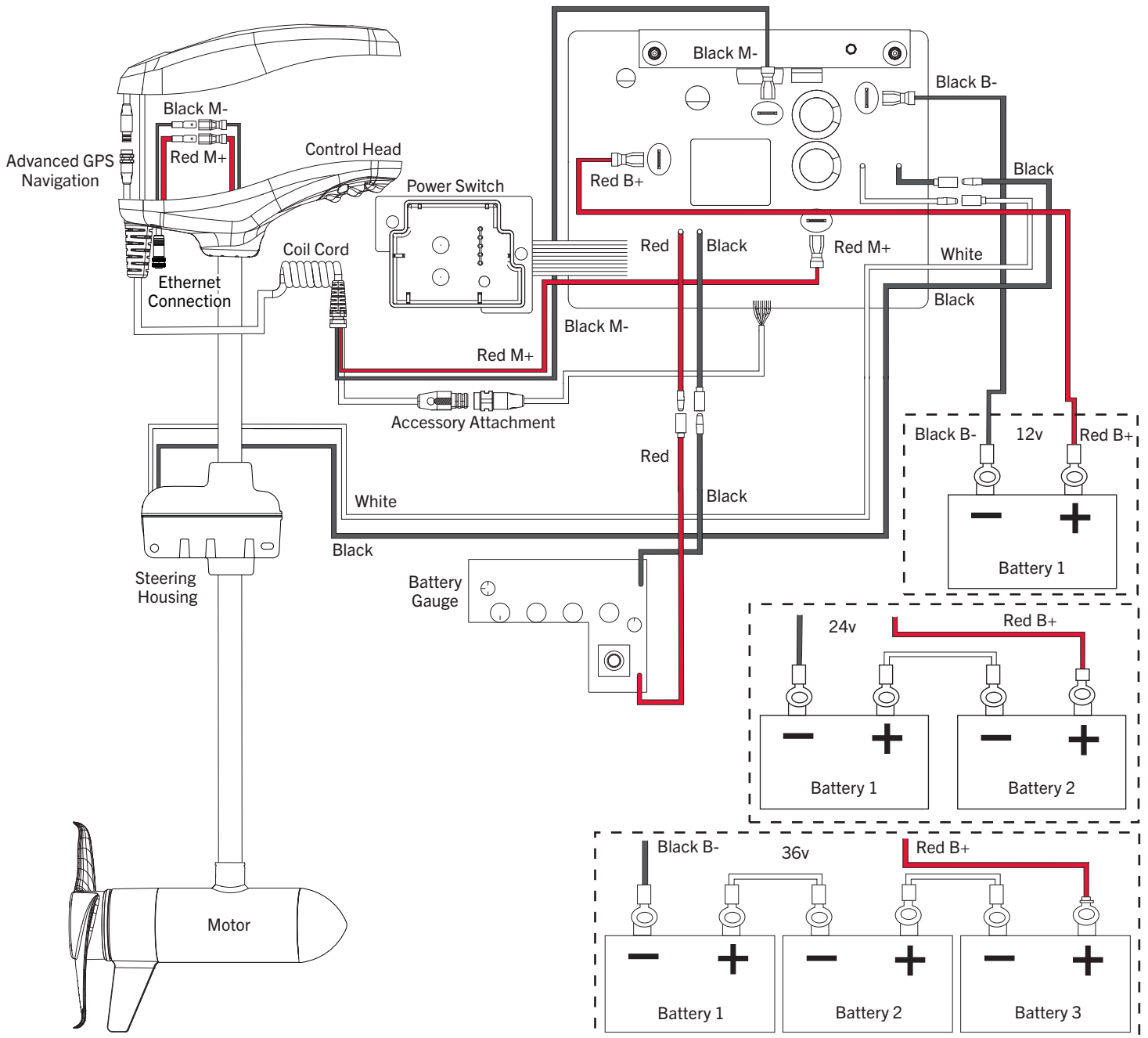

**NOTICE:** This is a multi-voltage diagram. Double-check your motor's voltage for proper connections. Over-Current Protection Devices are not shown in this illustration.



# USING & ADJUSTING THE MOTOR

## MOUNT FEATURES

Become familiar with the features of the motor to maximize the capabilities this product offers.

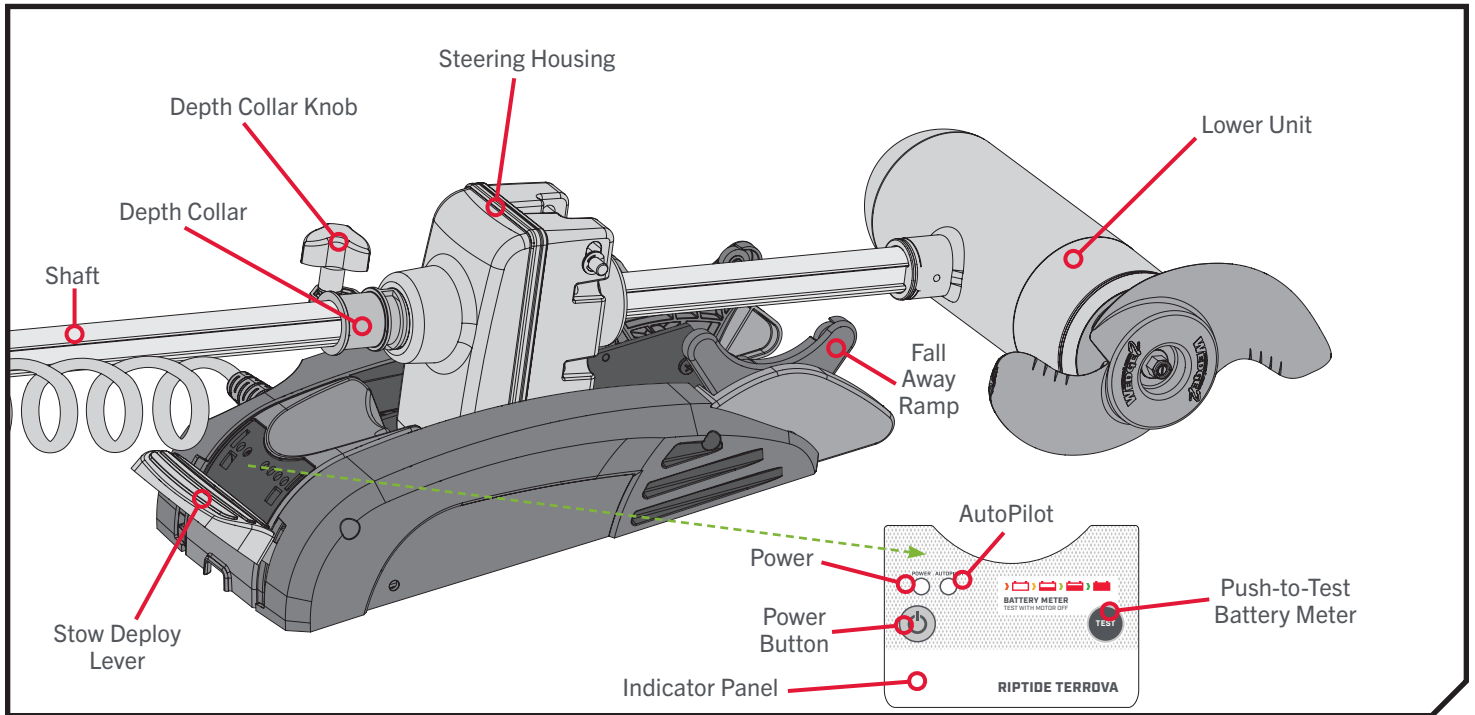



### › Depth Collar & Depth Collar Knob

The Depth Collar is located on the Shaft above the Steering Housing. It functions to hold the motor at the proper depth while deployed. It also functions to hold the Lower Unit in place when stowed while not in use and during transport. The Depth Collar Knob is used to loosen and tighten the Depth Collar so that it can slide up and down the motor shaft.

### › Fall Away Ramps

The Fall Away Ramps hold the Lower Unit when the Motor is stowed and rotate to release the Lower Unit as the unit is being deployed. When the Stow Deploy Lever is pressed it unlocks the position of the Fall Away Ramps and the Ramps rotate to guide the Lower Unit back onto the mount when the motor is stowed.

### › Power Button

The Power button  is located on the Indicator Panel on the Mount. The Riptide Terrova must be manually powered "on" and "off." When the Motor is powered "on," the Power Indicator will be illuminated green . When the Motor is powered "off," the Power Indicator will not be illuminated .

**NOTICE:** Do not completely remove the Depth Collar Knob from the Depth Collar Assembly. Doing so allows a washer-shaped spacer to fall out of the Depth Collar. This spacer plays a key role in creating tension for the Depth Collar to clamp and function properly.

## WARNING

When the motor is being transported, it is important to place the Depth Collar snug against the Steering Housing and tighten. This provides a secure stow and holds the motor in place during transportation when it is subject to high levels of shock and vibration. Failure to secure the motor may result in injury or damage to the unit.

## WARNING

When stowing or deploying the motor, keep fingers clear of all hinge and pivot points and all moving parts.



# ADJUSTING THE DEPTH OF THE MOTOR



## CAUTION

For safety reasons, disconnect the motor from the battery/batteries when the motor is not in use or while the battery/batteries are being charged. If the motor control is left on and the propeller rotation is blocked, severe motor damage can result.

### › AutoPilot

The AutoPilot Indicator is located on the Indicator Panel on the Mount. It is illuminated green  when AutoPilot is engaged and it is not illuminated  when AutoPilot is not engaged.

### › Stow Deploy Lever

The Stow Deploy Lever is located at the top of the mount. The Stow Deploy Lever functions to unlatch the Fall Away Ramps which rotate to guide the Lower Unit. The Stow Deploy Lever is actuated by pressing it down.

## STOWING AND DEPLOYING THE MOTOR

### › To Deploy the Motor

Loosen the Depth Collar then push firmly down on the Stow Deploy Lever. Slide the motor forward, out from the Fall Away Ramp. Lower the motor to the desired depth. Make sure it clicks into a secure, vertical position. Once at the desired depth, slide the Depth Collar against the Steering Housing and tighten.

## WARNING

When stowing or deploying the motor, keep fingers clear of all hinge and pivot points and all moving parts.

### › To Stow the Motor

Loosen the Depth Collar and depress the Stow Deploy Lever. Raise the motor by pulling up on the Shaft or Control Head. Pull the motor toward the stern until it rests securely on the Fall Away Ramp and the Fall Away Ramps captures the Lower Unit. Slide the Depth Collar down and secure it against the top of the Steering Housing to secure the motor in place and prevent accidental deployment.

## WARNING

The Control Head will create a pinch point if the Depth Collar Knob is loosened and the Control Head slides to the top of the Depth Collar. Grasp the Shaft and prevent it from sliding all the way down to prevent the pinch point.  
  
Practice proper ergonomics when stowing and deploying the motor to prevent injury.

## WARNING

Moving parts can cut or crush. Keep fingers clear of all moving parts.

## WARNING

If a propeller encounters an obstruction while running, the increased electrical current being generated by the obstruction will signal the motor to decrease the power to the propeller to prevent damage. If the current overload is detected for more than 20 seconds, the prop will be disabled to prevent damage to the motor. In this event, the operator can turn the prop back on after being sure that the obstruction has been cleared.

## ADJUSTING THE DEPTH OF THE MOTOR

### PUSH-TO-TEST BATTERY METER

This motor is equipped with a Push-to-Test Battery Meter. The LED located on the Indicator Panel on the Mount of the motor. The Battery Meter provides an accurate display of the remaining charge in the battery. It is only accurate when the motor is off. The meter reads as follows:

- One light indicates recharge.
- Two lights indicate low charge.
- Three lights indicate good charge.
- Four lights indicate full charge.

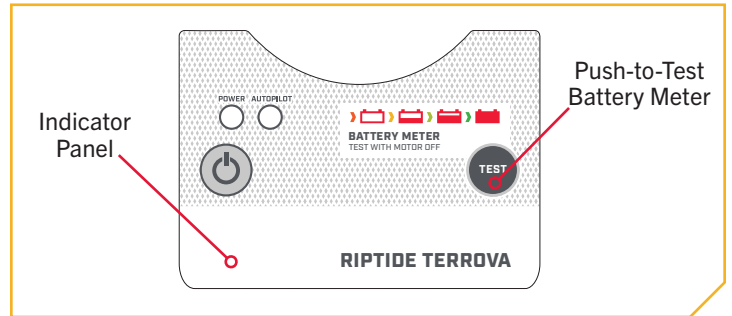

**NOTICE:** No lights indicates no battery connection or an incorrect battery connection.

# ADJUSTING THE DEPTH OF THE MOTOR

## MOTOR ADJUSTMENTS >

### ADJUSTING THE DEPTH OF THE MOTOR

Once the boat is on the water, it may be necessary to adjust the Lower Unit up or down to achieve an optimum depth for motor performance. When setting the depth of the motor, be sure the top of the motor is submerged at least 12" below the surface of the water to avoid churning or agitation of surface water.

- 1 a. With the motor in the deployed position, locate the Depth Collar on the Shaft above the Steering Housing.
- b. While holding the Shaft, loosen the Depth Collar Knob until the Shaft can slide up and down freely.

#### **WARNING**

The Control Head will create a pinch point if the Depth Collar Knob is loosened and the Control Head slides to the top of the Depth Collar. Grasp the Shaft and prevent it from sliding all the way down to prevent the pinch point.

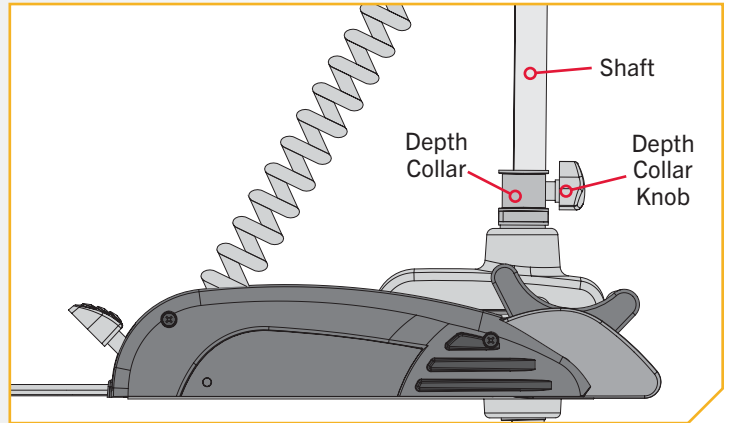

- 2 c. Raise or lower the motor to the desired depth.
- d. Turn the motor Control Head to the desired position.
- e. Slide the Depth Collar against the Steering Housing and tighten the Depth Collar Knob to secure the motor in place.

**NOTICE:** Be sure the top of the motor is submerged at least 12" below the surface of the water to avoid churning or agitation of surface water.

#### **WARNING**

Watch for sharp points that can be a puncture hazard. Always use care when handling the motor.

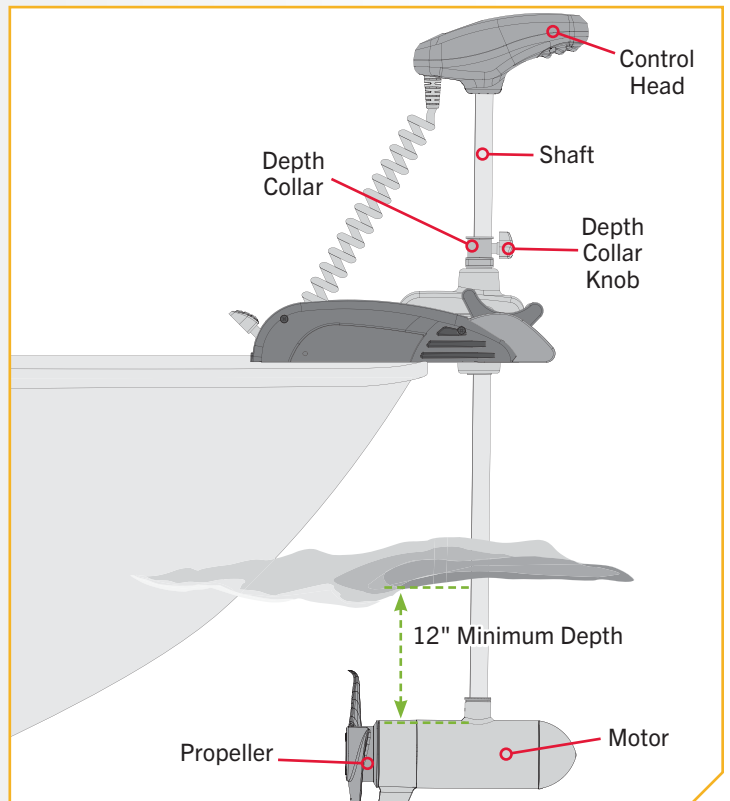

# ADJUSTING THE LOWER UNIT FOR A SECURE STOW

## ADJUSTING THE LOWER UNIT FOR A SECURE STOW

When the Motor is stowed, the Lower Unit should rest on the Fall Away Ramps, a part of the Motor Mount. It is recommended to secure the motor using the following instructions to avoid damage to the motor and shaft from vibrations during transport.

- 1**
- Before transporting the boat over water or land, stow the motor to determine where the Lower Unit rests on the Fall Away Ramps.

**NOTICE:** The correct positioning of the Lower Unit will place it directly on the Fall Away Ramps.

- If the Lower Unit does not sit on the Fall Away Ramps, deploy the motor, and stow it again.
- Be sure to press the Stow Deploy Lever and adjust the Motor to allow it to rest on the Fall Away Ramps.

### **CAUTION**

The Lower Unit should be placed on the Mount Ramps every time the motor is transported. If the Lower Unit is improperly placed, either above or below the Motor Rest Area, damage to the Lower Unit or Shaft will occur and the Shaft will be incorrectly captured. Not following the recommended placement for the Lower Unit will cause damage to the product and void your product warranty.

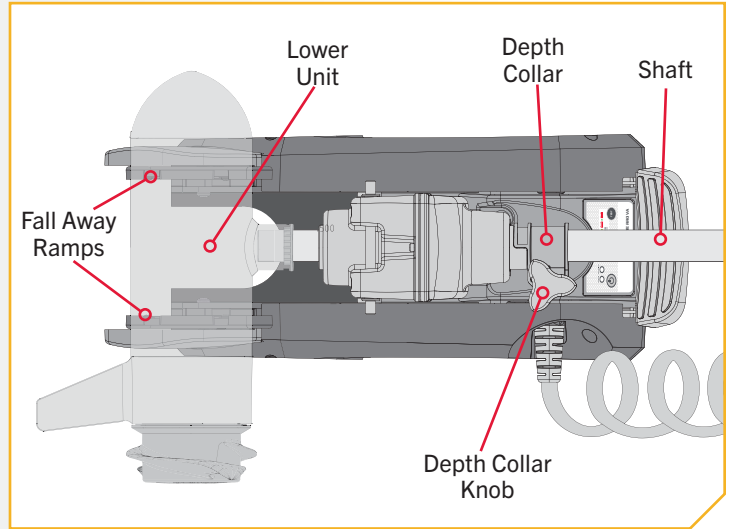

**NOTICE:** Slide the Depth Collar down and secure it against the top of the Steering Housing when stowed to secure the motor in place and prevent accidental deployment.

### **WARNING**

When the motor is stowed the depth collar must be positioned against the steering housing and tightened in place with the knob to prevent accidental deployment, which may result in injury, or damage to the trolling motor, accessories, or boat.

### **WARNING**

When the motor is being transported, it is important to place the Depth Collar snug against the Steering Housing and tighten. This provides a secure stow and holds the motor in place during transportation when it is subject to high levels of shock and vibration. Failure to secure the motor may result in injury or damage to the unit.

# INSTALLING AN EXTERNAL TRANSDUCER

## INSTALLING AN EXTERNAL TRANSDUCER

An external transducer is not included with your trolling motor. An external transducer can be installed onto the motor.

- 1
  - a. Mount the External Transducer according to directions provided with the transducer.
  - b. Leave enough slack in the Transducer Cable between the Lower Unit and Control Head to allow the motor to properly stow and deploy.
  - c. Use two tie wrap cables to secure the Transducer Cable to the Shaft just above the Lower Unit and just below the Control Head.
  - d. Run the Transducer Cable through the Coil Cord to the power supply.

### CAUTION

Failure to follow the recommended wire routing for the Advanced GPS Navigation and External Transducer Cables may cause damage to the product and void your product warranty. Take care to test the length and placement of cable to be sure that there is enough slack where needed and that cables are free of being entangled in moving parts. Routing the cables in any way other than directed may cause damage to the cables by being pinched or severed.

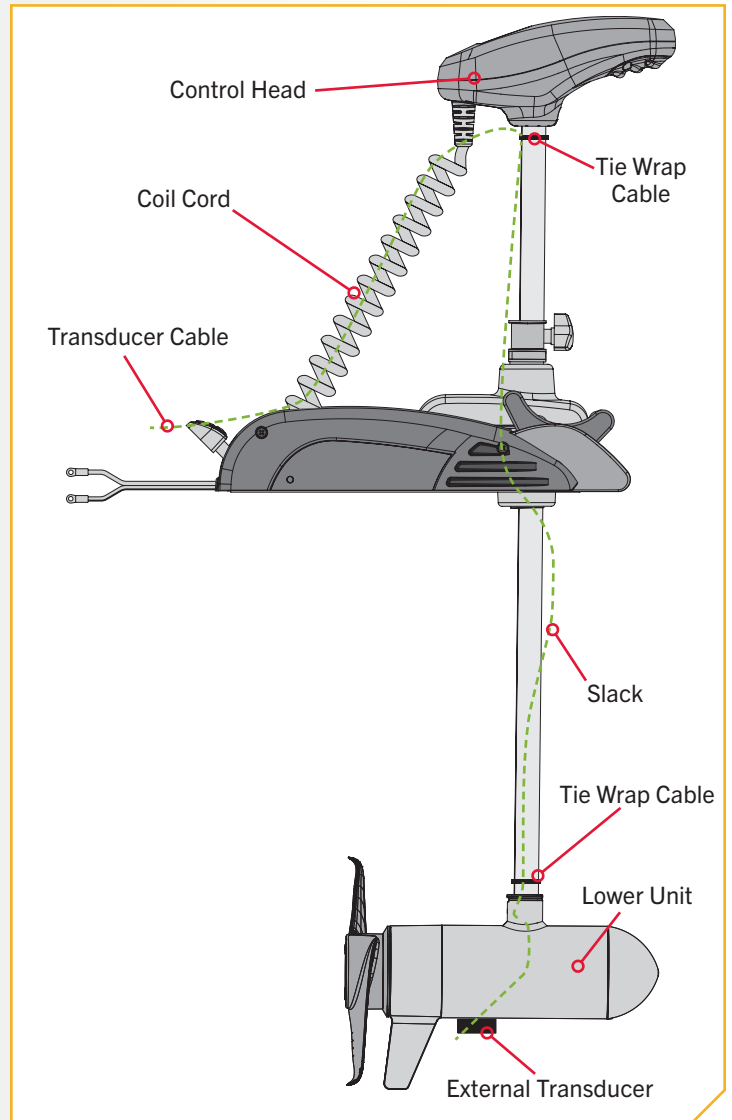

# SERVICE & MAINTENANCE

## PROPELLER REPLACEMENT

### TOOLS AND RESOURCES REQUIRED >

- 9/16" Open End Wrench
- Flat Blade Screwdriver

### INSTALLATION >

- Disconnect the motor from all sources of power prior to changing the propeller.
  - Hold the propeller and loosen the Prop Nut with a pliers or a wrench.
  - Remove the Prop Nut and Prop Washer.

**NOTICE:** If the Drive Pin is sheared or broken, you will need to hold the shaft stationary with a flat blade screwdriver pressed into the slot on the end of the shaft while you loosen the Prop Nut.

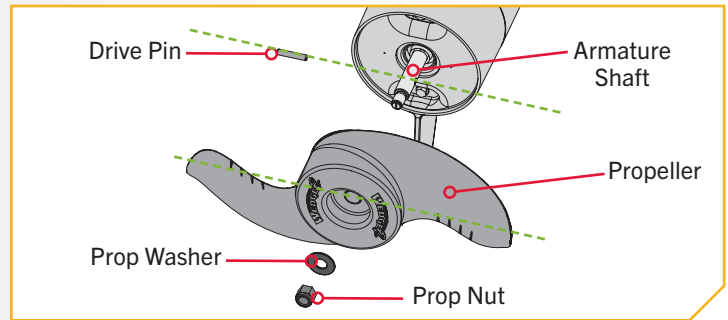

### ⚠ CAUTION

Disconnect the motor from the battery before beginning any prop work or maintenance.

- Turn the old prop to horizontal and pull it straight off. If drive pin falls out, push it back in.

### ⚠ CAUTION

If the prop does not readily slide off, take care to not bend the Armature Shaft while removing the prop by pulling the prop evenly off the Armature Shaft.

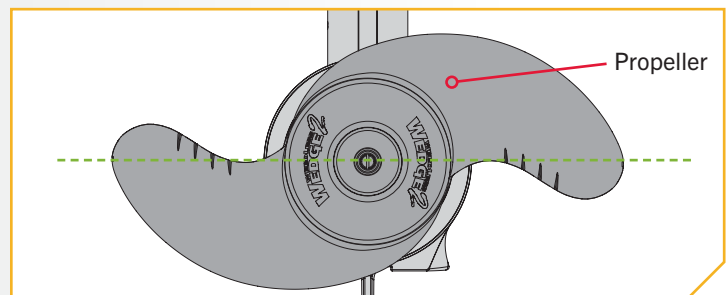

- Align the new Propeller with the Drive Pin.
  - Install the Prop Washer and Prop Nut.
  - Tighten the Prop Nut 1/4 turn past snug at 25-35 inch-lbs.

### ⚠ CAUTION

Do not over tighten as this can damage the prop.

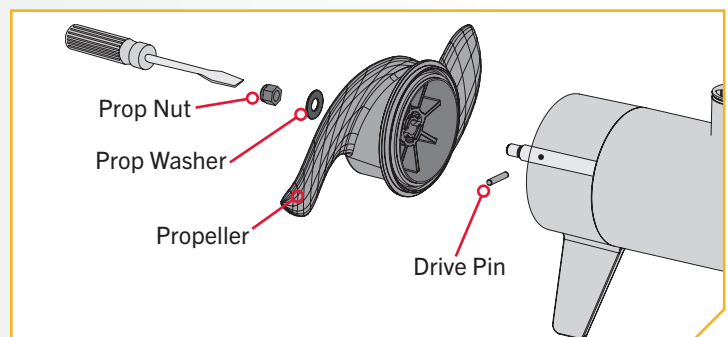

# SERVICE & MAINTAINANCE



## GENERAL MAINTENANCE

- After every use, the entire motor should be rinsed with freshwater, then wiped down with a cloth dampened with an aqueous-based silicone spray. Do not spray water into the ventilation openings in the head of the motor.
- The composite shaft requires periodic cleaning and lubrication for proper retraction and deployment. A coating of an aqueous-based silicone spray will improve operation.
- The propeller must be inspected and cleaned of weeds and fishing line after every use. Fishing line and weeds can get behind the prop, damage the seals and allow water to enter the motor.
- Verify that the prop nut is secure each time the motor is used.
- To prevent accidental damage during transportation or storage, disconnect the battery whenever the motor is off of the water. For prolonged storage, lightly coat all metal parts with an aqueous-based silicone spray.
- For maximum battery life, recharge the battery(s) as soon as possible after use. For maximum motor performance, restore battery to full charge prior to use.
- Keep battery terminals clean with fine sandpaper or emery cloth (flooded lead-acid only).
- The propeller is designed to provide weed-free operation with very high efficiency. To maintain this top performance, the leading edge of the blades must be kept smooth. If they are rough or nicked from use, restore to smooth by sanding with fine sandpaper.

## TROUBLESHOOTING

1. Motor fails to run or lacks power:
  - Check battery connections for proper polarity.
  - Make sure terminals are clean and corrosion free. Use fine sandpaper or emery cloth to clean terminals.
  - Check battery water level. Add water if needed.
2. Motor loses power after a short running time:
  - Check battery charge. If low, restore to full charge.
3. If you experience prop vibration during normal operation:
  - Remove and rotate the prop 180°. See removal instructions in the Propeller Replacement Section.
4. Experiencing interference with your fishfinder:
  - You may, in some applications, experience interference in your depth finder display. We recommend that you use a separate deep cycle marine battery for your trolling motor and that you power the depth finder from the starting/cranking battery. If problems still persist, call our service department at 1-800-227-6433.

**NOTICE:** For all other malfunctions, visit an Authorized Service Center. You can search for an Authorized Service Center in your area by visiting [minnkotamotors.com](http://minnkotamotors.com), or by calling our customer service number at 800-227-6433.



FOR FURTHER TROUBLESHOOTING AND REPAIR

We offer several options to help you troubleshoot and/or repair your product. Please read through the options listed below.



Buy Parts Online

You can buy parts online directly from our website at minnkotamotors.com. From screws to sideplates, you can order replacement parts for your Minn Kota products.



Frequently Asked Questions

Find answers to general inquiries, battery and rigging installation, and networking scenarios. We have FAQs available on our website at minnkotamotors.com to help answer all of your Minn Kota questions.



Call Us (for U.S. and Canada)

Our consumer service representatives are available Monday – Friday between 7:00 a.m. – 4:30 p.m. CST at 800-227-6433. If you are calling to order parts, please have the 11-character serial number from your product, specific part numbers, and credit card information available. This will help expedite your call and allow us to provide you with the best consumer service possible. You can reference the parts list located in your manual to identify the specific part numbers.



Contact Us

You can contact our consumer service department with questions regarding your Minn Kota products. To inquire, visit minnkotamotors.com.



Authorized Service Centers

Minn Kota has over 800 authorized service centers in the United States and Canada where you can purchase parts or get your products repaired. Please visit our website to locate a service center in your area.



Scan to visit Minn Kota service online.

# COMPLIANCE STATEMENTS

## ENVIRONMENTAL COMPLIANCE STATEMENT

It is the intention of JOME to be a responsible corporate citizen, operating in compliance with known and applicable environmental regulations, and a good neighbor in the communities where we make or sell our products.

### WEEE DIRECTIVE

EU Directive 2002/96/EC “Waste of Electrical and Electronic Equipment Directive (WEEE)” impacts most distributors, sellers, and manufacturers of consumer electronics in the European Union. The WEEE Directive requires the producer of consumer electronics to take responsibility for the management of waste from their products to achieve environmentally responsible disposal during the product life cycle.

WEEE compliance may not be required in your location for electrical & electronic equipment (EEE), nor may it be required for EEE designed and intended as fixed or temporary installation in transportation vehicles such as automobiles, aircraft, and boats. In some European Union member states, these vehicles are considered outside of the scope of the Directive, and EEE for those applications can be considered excluded from the WEEE Directive requirement.

This symbol (WEEE wheelee bin) on product indicates the product must not be disposed of with other household refuse. It must be disposed of and collected for recycling and recovery of waste EEE. Johnson Outdoors Inc. will mark all EEE products in accordance with the WEEE Directive. It is our goal to comply in the collection, treatment, recovery, and environmentally sound disposal of those products; however, these requirements do vary within European Union member states. For more information about where you should dispose of your waste equipment for recycling and recovery and/or your European Union member state requirements, please contact your dealer or distributor from which your product was purchased.



### DISPOSAL

Minn Kota motors are not subject to the disposal regulations EAG-VO (electric devices directive) that implements the WEEE directive. Nevertheless never dispose of your Minn Kota motor in a garbage bin but at the proper place of collection of your local town council.

Never dispose of battery in a garbage bin. Comply with the disposal directions of the manufacturer or his representative and dispose of them at the proper place of collection of your local town council.

## REGULATORY COMPLIANCE INFORMATION

### › Motors with Advanced GPS Navigation

For regulatory information on motors with Advanced GPS Navigation, please refer to the Advanced GPS Navigation Manual online at [minnkotamotors.com](http://minnkotamotors.com).



## FCC COMPLIANCE

This device complies with Part 15 of the FCC rules. **Operation is subject to the following two conditions:**

1. This device may not cause harmful interference.
2. This device must accept any interference that may be received, including interference that may cause undesired operation.

Changes or modifications not expressly approved by Johnson Outdoors Marine Electronics, Inc. could void the user’s authority to operate this equipment.

**NOTICE:** This equipment has been tested and found to comply with the limits for a Class B digital device, pursuant to part 15 of the FCC Rules. These limits are designed to provide reasonable protection against harmful interference in a residential installation. This equipment generates, uses and can radiate radio frequency energy and, if not installed and used in accordance with the instructions, may cause harmful interference to radio communications. However, there is no guarantee that interference will not occur in a particular installation. **If this equipment does cause harmful interference to radio or television reception, which can be determined by turning the equipment off and on, the user is encouraged to try to correct the interference by one or more of the following measures:**

- Reorient or relocate the receiving antenna.
- Increase the separation between the equipment and receiver.
- Connect the equipment into an outlet on a circuit different from that to which the receiver is connected.
- Consult the dealer or an experienced radio/TV technician for help.

## INDUSTRY CANADA COMPLIANCE

This product meets the applicable Industry Canada technical specifications. Operation is subject to the following two conditions: (1) this device may not cause interference, and (2) this device must accept any interference, including interference that may cause undesired operation of the device.

Changes or modifications not expressly approved by Johnson Outdoors Marine Electronics, Inc. could void the user’s authority to operate this equipment.

## ENVIRONMENTAL RATINGS

Ambient operating temperature range: -10C to 50C

Ambient operating humidity range: 5% to 95%

Maximum operating altitude: 10,000 feet



# PARTS DIAGRAM & PARTS LIST

## RIPTIDE TERROVA - 55/80/112 LBS THRUST - 12/24/36 VOLT - 54"/60"/72" SHAFT

The parts diagram and parts list provides Minn Kota® WEEE compliance disassembly instructions. For more information about where you should dispose of your waste equipment for recycling and recovery and/or your European Union member state requirements, please contact your dealer or distributor from which your product was purchased. Tools required, but not limited to: flat head screwdriver, Phillips screwdriver, socket set, pliers, wire cutters.

### RIPTIDE TERROVA CONTROL HEAD >

#### > Control Head Parts Diagram

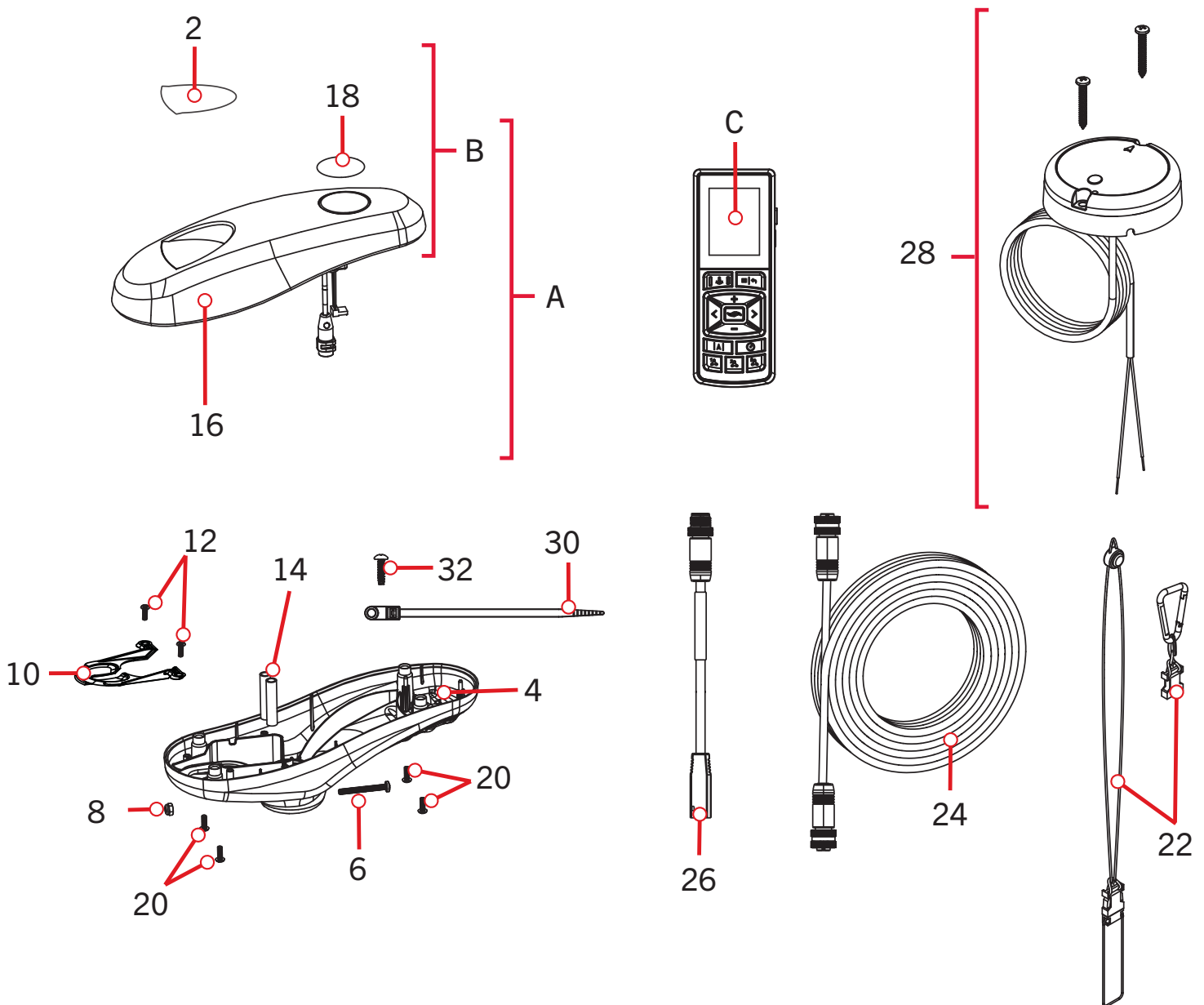

# PARTS DIAGRAM & PARTS LIST

## Control Head Parts List

Assembly	Part #	Description	Notes	Quantity
A	2774104	MTR KIT, 4.0 PM SW WR		1
B	2770243	CVR KIT, ADV GPS NAV, RT TRV		1
C	411690-1	TROLLING MOTOR REMOTE		1
Item	Part #	Description	Notes	Quantity
▲	✘	SEAL,BUNG LOWER		1
▲	✘	SEAL,BUNG UPPER,SW		1
▲	2256300	TIE WRAP-6.0" BLACK		2
2	2395567	DECAL,PUSH BTN TOP 55# SW	*55LB*	1
	2395568	DECAL,PUSH BTN TOP 80# SW	*80LB*	1
	2395569	DECAL,PSH BTN TOP 112# SW	*112LB*	1
4	2292501	CONTROL BOX, SW ST/T2		1
6	2263406	SCREW-#10-24 X 2" SS PPH		1
8	2333101	NUT-HEX #10-24 UNC-2B NYL SS		1
10	2224707	PLUG, SCREW-DOWN, WHT		1
12	2203441	SCREW-#6 X 1/2" THRD FORM,SSTL		2
14	2305402	SHRINK TUBE-.374 OD X 2.25"		2
16	2290213	COVER,CTRL BOX iP, RT PD PRTD		1
18	2395529	DECAL, DOMED SW		1
20	2372100	SCREW-#8-18 X 5/8 THD* (SS		4
22	2390802	LANYARD w/CARABINER IP RMT U2		1
24	490384-4	CABLE, ETHERNET (M12-M12), 30'		1
26	490380-1	CABLE, ETHERNET PIGTAIL-700 HD		1
28	2996400	HEADING SENSOR ASSEMBLY		1
30	2206302	TIE WRAP, SCREW MOUNT 6.3"		1
32	2203441	SCREW-#6 X 1/2" THRD FORM,SSTL		1
▲	2327135	MANUAL, RT TERROVA 3 PM		1
▲	2327137	MANUAL-INSTLL GD RT T3 PM		1
▲	2397110	MANUAL, WIRELESS REMOTE		1
▲	2397115	GUIDE-QCK REFERNC WIRELESS REMOTE		1
▲	2297165	MANUAL-DISCLAIMER,DWNLOAD INFO		1
▲	2015800	HANG TAG "CAUTION TILT HINGE"		1
▲	2394900	INSTRUCTIONS, HEADING SENSOR		1
▲	2294950	INSTRUCTIONS,OBN & REMOTE PAIR		1

▲ Not shown on Parts Diagram.

✘ This part is included in an assembly and cannot be ordered individually.

# PARTS DIAGRAM & PARTS LIST

## RIPTIDE TERROVA MOTOR

### 12 Volt 3.625" Motor Parts Diagram

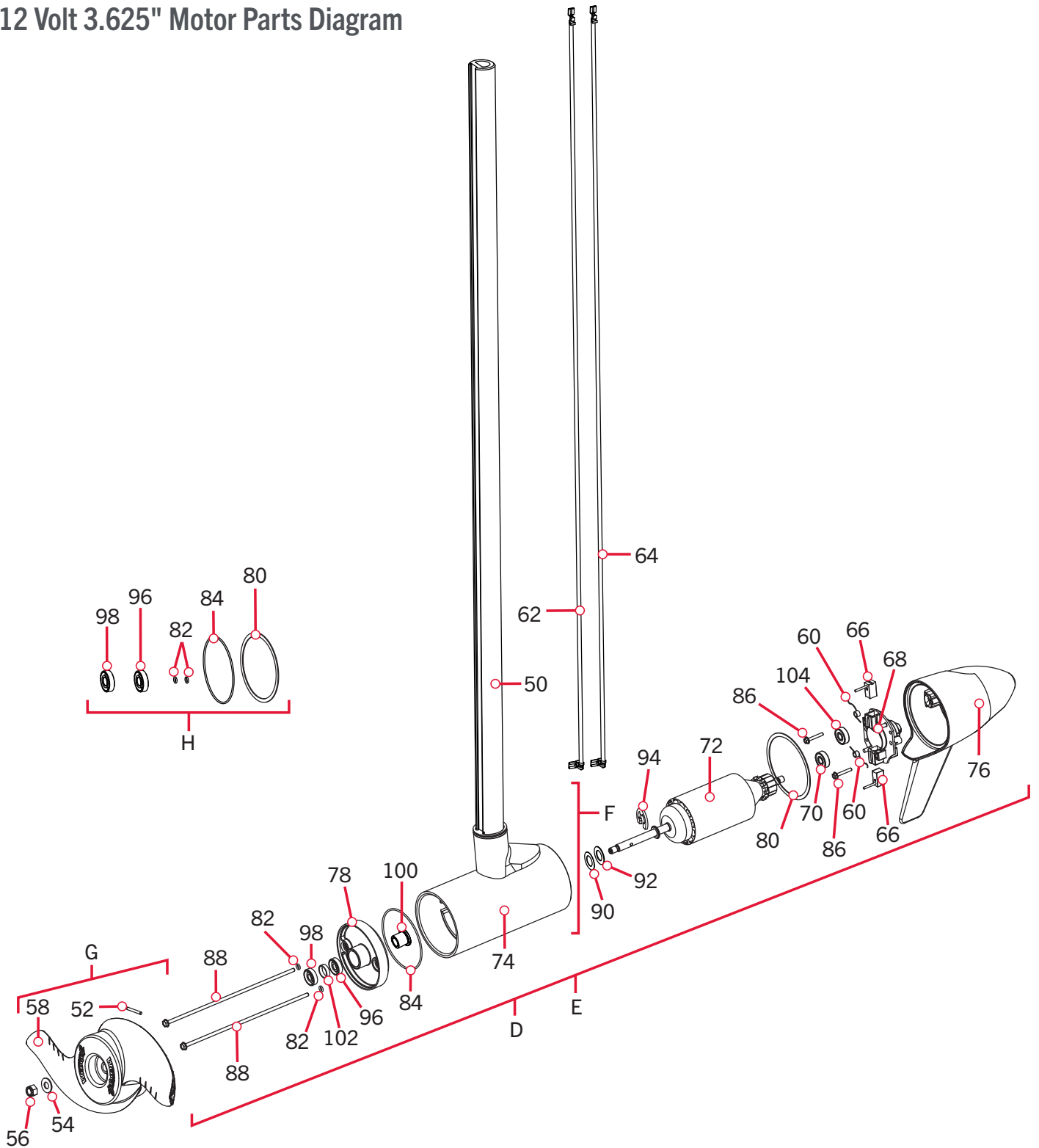

# PARTS DIAGRAM & PARTS LIST

## ▶ 12 Volt 3.625" Motor Parts List

Assembly	Part #	Description	Notes	Quantity
D	2779034	MTR/TUBE ASM 55# 54" RT TRV BT	*54"	1
E	2119037	MTR ASY 12V 3.62" 55# SW	*60"	1
F	2779307	CTR HSG, CB, 55#, SW 60"		1
G	1378170	PROP KIT 2091170 PWR PRP GENII	*55LB*	1
H	2888460	SEAL & O-RING KIT		1
Item	Part #	Description	Notes	Quantity
50	✖	TUBE-COMP,WHT,54",1/4" WALL	*54"	1
	✖	TUBE-COMP,WHT,60",1/4" WALL	*60"	1
52	2092602	PIN-DRIVE 1.06 X 1/8 SS 17-4	*55LB*	1
54	2151726	WASHER-5/16 STD (S/S)		1
56	2053101	NUT-PROP,NYLOC(MED) 5/16-24 SS		1
58	2091170	PROP-PWR (3 5/8") REAMED	*55LB*	1
60	975-040	SPRING - TORSION		2
62	640-151	LEADWIRE RED 10 AWG 70.375 GPT	*54"	1
	640-110	LEADWIRE RED 10 AWG 73 GPT	*60"	1
64	640-023	LEADWIRE BLK 10 AWG 69" GPT	*54"	1
	640-011	LEADWIRE BLK 10 AWG 71 GPT	*60"	1
66	188-036	BRUSH ASSEMBLY 3.625		2
68	738-036	BRUSH PLATE WITH HOLDER 3.625		1
70	725-050	PAPER TUBE - BRUSH RETENTION		1
72	2-100-146	ARM ASY 12V 3.62 55#CB/LS		1
74	✖	CTR HSG ASY 3.6 SW/CB/W-MG		1
76	421-350	HSG BRSH END 3.62 SW CB/WHITE		1
78	2-400-337A	PLAIN END HSG ASY 3.6 W		1
80	337-036	GASKET		1
82	701-008	O-RING	*THRU-BOLT*	2
84	701-081	O-RING		1
86	830-007	SCREW, # 8-32		2
88	830-108	THRU BOLT 10-32 X 9.205 COATED		2
90	990-067	WASHER - STEEL THRUST		1
92	990-070	WASHER - NYLATRON		1
94	788-015	RETAINING RING		1
96	880-003	SEAL		1
98	880-006	SEAL WITH SHIELD		1
100	144-049	BEARING-FLANGE		1
102	725-035	PAPER TUBE - SEAL BORE		1
104	140-010	BEARING - BALL		1

▲ Not shown on Parts Diagram.

✖ This part is included in an assembly and cannot be ordered individually.

# PARTS DIAGRAM & PARTS LIST

## 24 Volt 4" Motor Parts Diagram

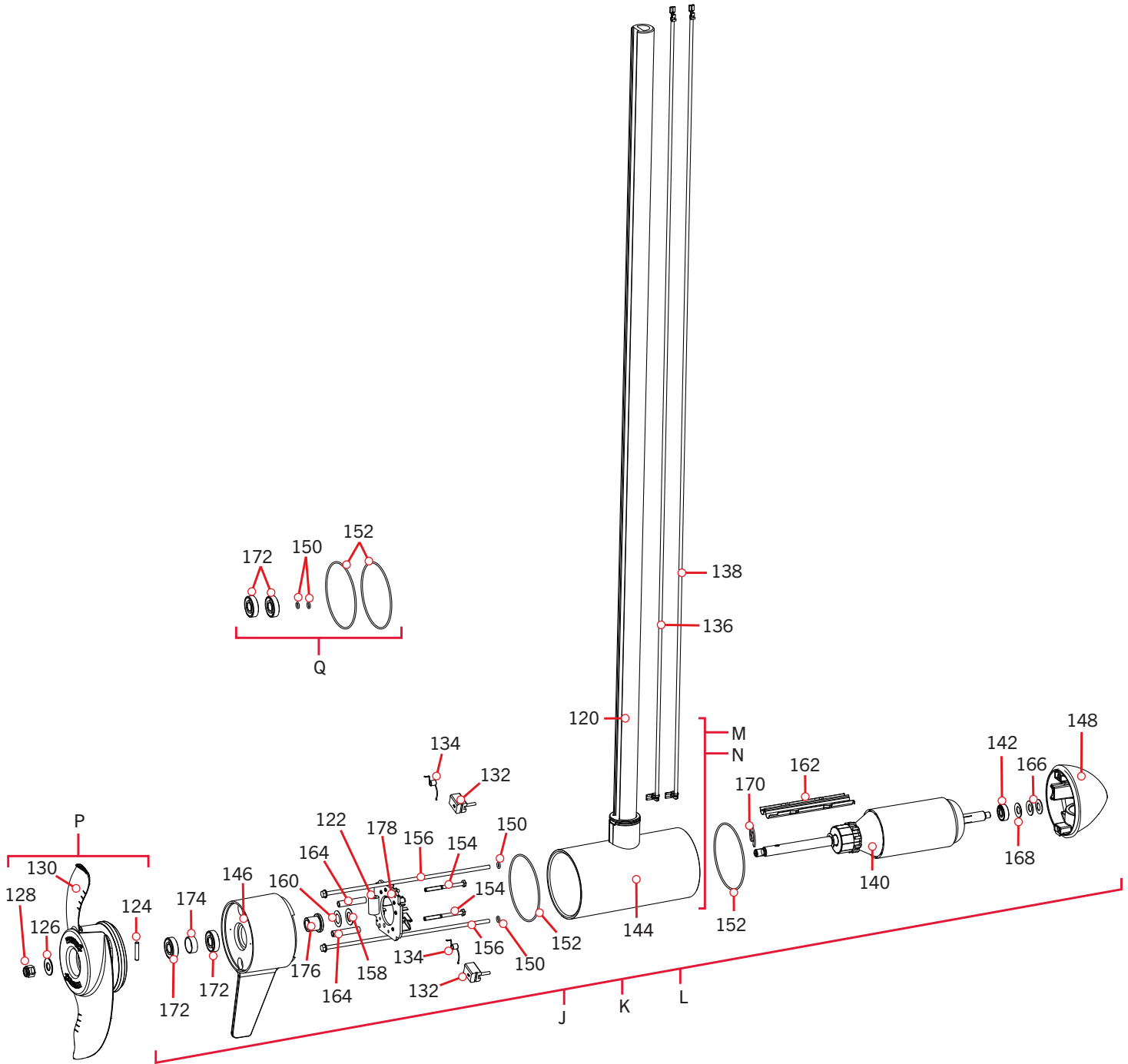



## PARTS DIAGRAM & PARTS LIST

### ▶ 24 Volt 4" Motor Parts List

Assembly	Part #	Description	Notes	Quantity
J	2777034	MTR/TUBE ASM 80# 54" RT TRV BT	*54"	1
K	2777036	MTR/TUBE ASM 80# 60" RT TRV BT	*60"	1
L	2777042	MTR/TUBE 80# 72" RT TRV-M BT	*72"	1
M	2777398	CTR HSG,CB,80#,SW, UP TO 60"	*54" *60"	1
N	2777399	CTR HSG,CB,80#,SW,72" RT TRV	*72"	1
P	1378132	PROP IND 233160 WDLS WDG II	*80LB*	1
Q	2889460	SEAL & O-RING KIT		1
Item	Part #	Description	Notes	Quantity
120	✘	TUBE-COMP,WHT,54",1/4" WALL	*54"	1
	✘	TUBE-COMP,WHT,60",1/4" WALL	*60"	1
	✘	TUBE-COMP, WHT, 72" BORED	*72"	1
	✘	TUBE-CMP,WHT,72",1/4","M"	*72"	
122	2307312	BEAD-FERRITE		1
124	2262659	PIN-DRIVE 1" X 3/16 SS 17-4	*80LB*	1
126	2091701	WASHER-PROP (LARGE)		1
128	2093101	NUT-PROP,NYLOC,LG,MX101 3/8 SS		1
130	2331161	PROP-WW2 4" WELDED	*80LB*	1
132	188-094	BRUSH W/TERMINAL		2
134	975-041	SPRING - TORSION		2
▲	✘	RIVET - .25"		6
136	640-133	LEADWIRE RED 10AWG 66-1/4 XLP	*54"	1
	640-126	LEADWIRE RED 10AWG 71" XLP	*60"	1
	640-155	LEADWIRE RED 10 AWG 83.625 XLP	*72"	1
138	640-025	LEADWIRE BLK 10 AWG 66 3/4 XLP	*54"	1
	640-022	LEADWIRE BLK 10 AWG 72.5 XLP	*60"	1
	640-053	LEADWIRE BLK 10 AWG 82.375 XLP	*72"	1
▲	✘	BRUSH HOLDER		2
▲	✘	CONNECTOR 1/4 MALE TAB QD		2
140	2-100-214	ARM ASSY 24V 4" 80# (WW2)		1
142	140-010	BEARING - BALL		1
144	2-200-395	CTR HSG ASM 4.0" SW CB MGNTZD		1
146	2-300-370	BRUSH END HSG ASY SW/W 4.0		1
148	421-376	HSG PLN END 4" SW WHT BS		1
150	701-009	O-RING	*THRU-BOLT*	2
152	701-043	O-RING		2
154	830-027	SCREW - SELF-THREAD 10-32X2.25		2

▲ Not shown on Parts Diagram.

✘ This part is included in an assembly and cannot be ordered individually.

# PARTS DIAGRAM & PARTS LIST



Item	Part #	Description	Notes	Quantity
156	830-194	THRU BOLT 12-24 X 10.31 COATED		2
158	990-051	WASHER - STEEL THRUST		1
160	990-052	WASHER - NYLATRON		1
162	582-013	CLIP, RETAINING SHORT		1
164	973-025	SPACER - BRUSHPLATE		2
166	992-010	WASHER - BELLEVILLE		2
168	990-045	SPACER - THRUST		1
170	788-040	RETAINING RING		1
172	880-025	SEAL		2
174	725-095	PAPER TUBE, SEAL		1
176	144-017	BEARING, FLANGE		1
178	9-738-015	BRUSH PLATE ASM 4" CTR BUNG		1

▲ Not shown on Parts Diagram.

✘ This part is included in an assembly and cannot be ordered individually.



▶ 36 Volt 4.5" Motor Parts Diagram

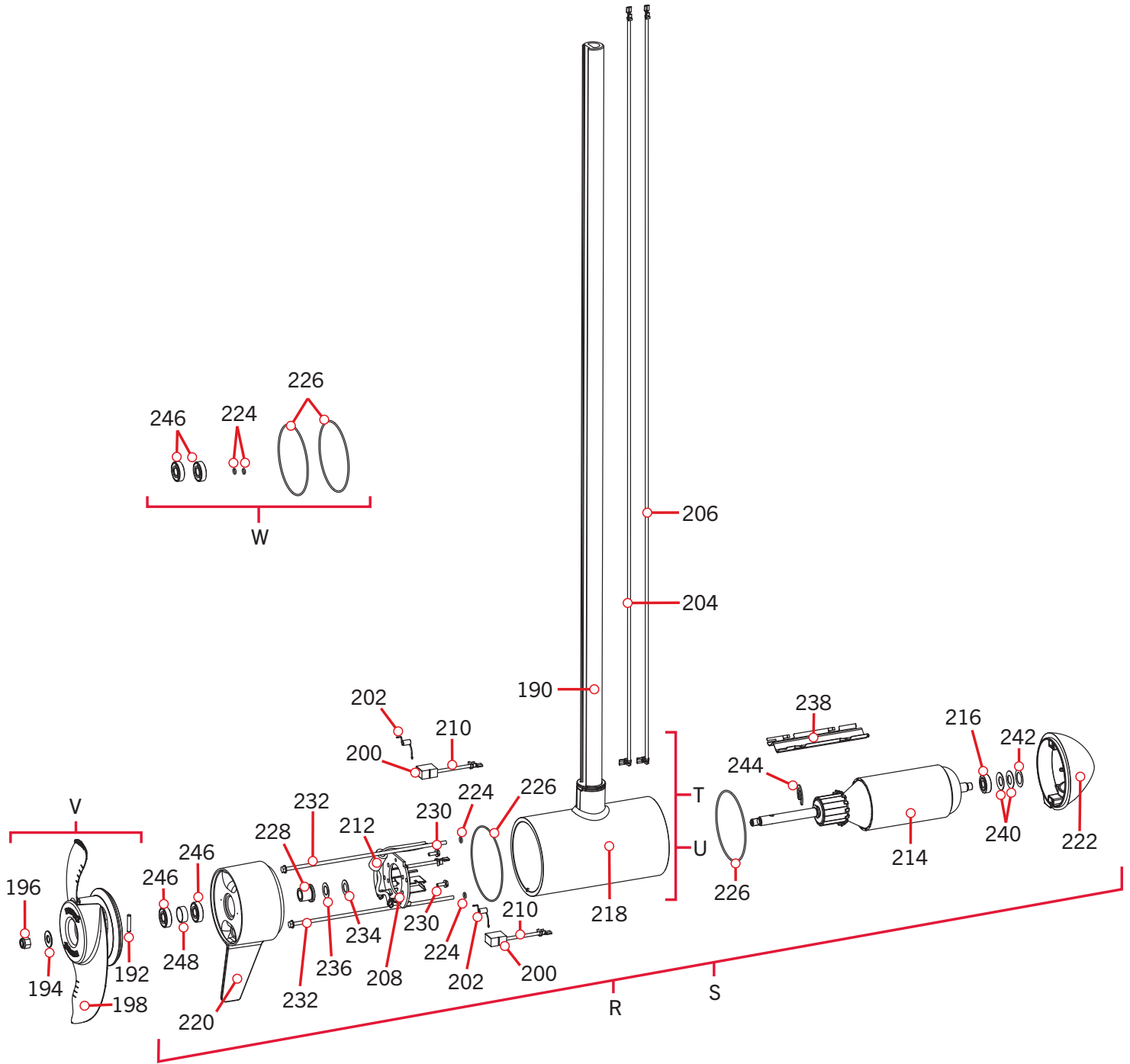

# PARTS DIAGRAM & PARTS LIST

## ▶ 36 Volt 4.5" Motor Parts List

Assembly	Part #	Description	Notes	Quantity
R	2777083	MTR/TUBE 112# 60" RT TRV BT	*60"	1
S	2777084	MTR/TUBE 112# 72" RT TRV BT	*72"	1
T	2777357	CTR HSG ASY,CB,112#,SW,60" TUBE	*60"	1
U	2777358	CTR HSG ASY,CB,112#,SW,72" TUBE	*72"	1
V	1378160	PROP KIT 2341160 112# WW2	*112LB*	1
W	2881450	SEAL & O-RING KIT		1
Item	Part #	Description	Notes	Quantity
190	✖	TUBE-COMP,WHT,60",1/4" WALL	*60"	1
	✖	TUBE-COMP, WHT, 72" BORED	*72"	1
192	2262659	PIN-DRIVE 1" X 3/16 SS 17-4	*112LB*	1
194	2091701	WASHER-PROP (LARGE)		1
196	2093101	NUT-PROP,NYLOC,LG,MX101 3/8 SS		1
198	2341161	PROP-WW2 4.5" WELDED	*112LB*	1
200	188-095	BRUSH		2
202	975-045	SPRING-TORSION		2
▲	✖	RIVET - .25"		6
204	640-145	LEADWIRE RED 10AWG 75 7/8" GPT	*60"	1
	640-149	LEADWIRE RED 10AWG 88" GPT	*72"	1
206	640-049	LEADWIRE BLK 10AWG 88.50" GPT	*60"	1
	640-045	LEADWIRE BLK 10 AWG 76.5 GPT	*72"	1
▲	✖	BRUSH HOLDER		2
208	9-738-011	BRUSH PLATE		1
210	2260731	TERMINAL 1/4" MALE TAB-THREE		2
212	2307312	BEAD-FERRITE		1
214	2-100-245	ARMATURE ASY 4.5"LWR UNIT		1
216	140-014	BEARING-BALL 6000		1
218	2-200-356	CTR HSG ASM 4.5" SW CB MGNTZD		1
220	2-300-176	BRUSH END HSG ASY 4.5" SW		1
222	421-241	PLAIN END HSG 4.5" PNTD SW		1
224	701-009	O-RING	*THRU-BOLT*	2
226	701-098	O-RING, 98MM X 2MM		2
228	144-017	BEARING, FLANGE		1
230	2053410	SCREW-#8-32 X 1/2 TRI-LOBE HEX		2
232	830-194	THRU BOLT 12-24 X 10.31 COATED		2
234	990-051	WASHER - STEEL THRUST		1
236	990-052	WASHER - NYLATRON		1

▲ Not shown on Parts Diagram.

✖ This part is included in an assembly and cannot be ordered individually.

# PARTS DIAGRAM & PARTS LIST



Item	Part #	Description	Notes	Quantity
238	582-016	CLIP-RETAINING, SONAR		1
240	992-011	WASHER - BELLEVILLE		2
242	990-011	WASHER-SHIM OD 1",ID.630"SS		1
244	788-040	RETAINING RING		1
246	880-025	SEAL		2
248	725-095	PAPER TUBE, SEAL		1

▲ Not shown on Parts Diagram.

✘ This part is included in an assembly and cannot be ordered individually.



# PARTS DIAGRAM & PARTS LIST

## RIPTIDE TERROVA STEERING HOUSING >

### > Steering Housing Parts Diagram

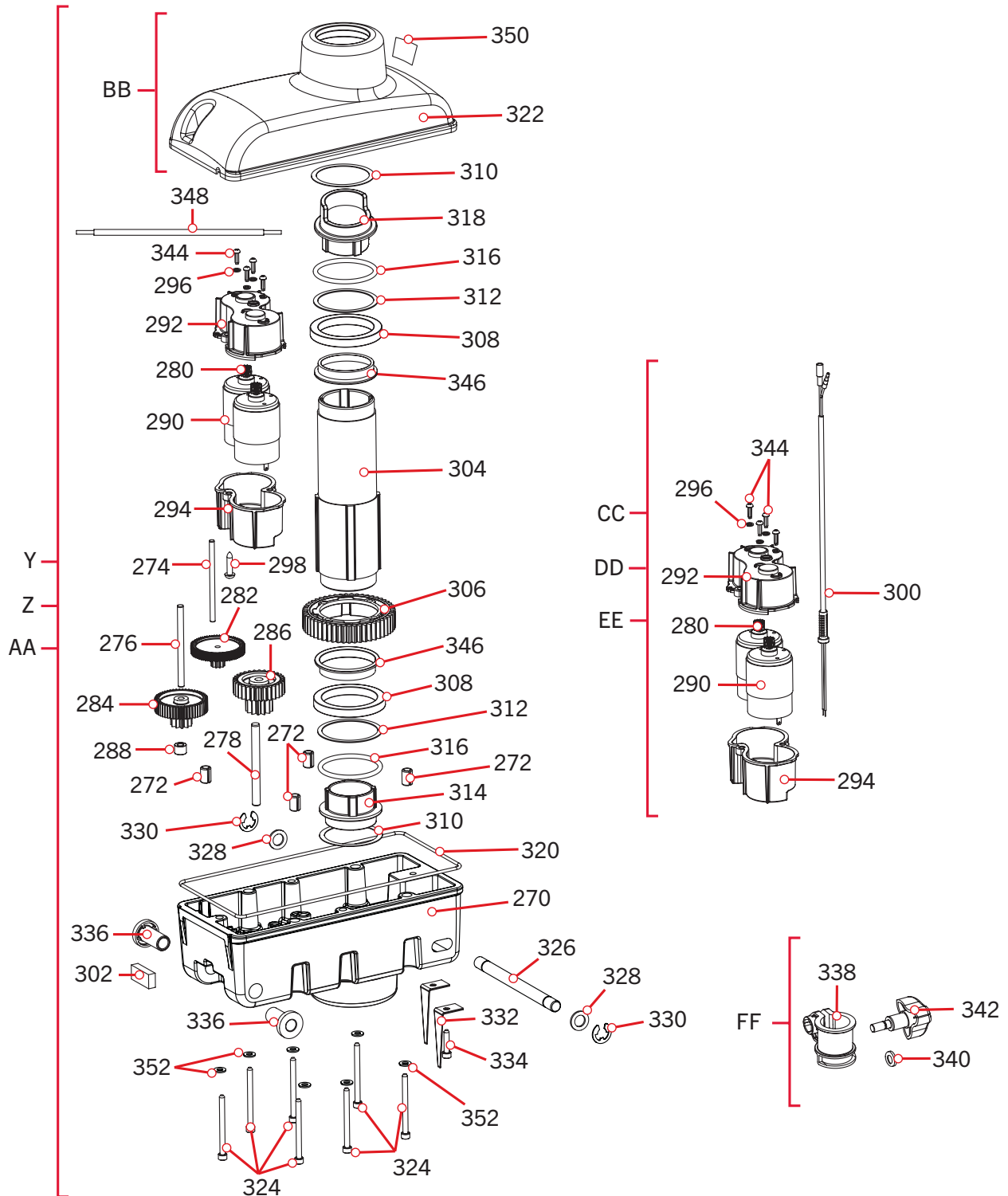

# PARTS DIAGRAM & PARTS LIST

## Steering Housing Parts List

Assembly	Part #	Description	Notes	Quantity
Y	2997056	STR HSG ASM w/BSHG 12V SW	*55LB*	1
Z	2997057	STR HSG ASM w/BSHG 24V SW	*80LB*	1
AA	2997058	STR HSG ASM w/BSHG 36V SW	*112LB*	1
BB	2776562	STEERING HSG TOP SW / GEAR KIT		1
CC	2777060	STEERING MOTOR KIT, 12V T2	*55LB*	1
DD	2777061	STEERING MOTOR KIT, 24V T2	*80LB*	1
EE	2777063	STEERING MOTOR KIT, 36V SW T2	*DUAL MOTOR* *112LB*	1
FF	2771505	DEPTH COLLAR KIT, TERROVA BT		1
Item	Part #	Description	Notes	Quantity
270	2326567	STEERING HSG,BTTM,SW,WHT		1
272	✘	PIN-ROLL 5/16" X 1/2"		4
274	✘	SHAFT-GEAR, FIRST CLUSTER		1
276	✘	SHAFT-GEAR,INTERMED.CLUSTER		1
278	✘	SHAFT-GEAR, THIRD CLUSTER		1
280	2322215	PINION GEAR, DR.HSG, STAGE 1	*55LB* *80LB*	1
	2322215	PINION GEAR, DR.HSG, STAGE 1	*112LB*	2
282	2322210	GEAR & PINION,DR. HSG, STAGE 2		1
284	2302250	GEAR & PINION,DR. HSG, STAGE 3		1
286	2302255	GEAR & PINION,DR. HSG, STAGE 4		1
288	2321730	SPACER,GEAR CLUSTER		1
290	✘	MOTOR, STEERING 12V T2	*SEE ASSEMBLY CC*	1
	✘	MOTOR, STEERING 24V T2	*SEE ASSEMBLY DD*	1
	✘	MOTOR,STEERING 36V FW T2	*SEE ASSEMBLY EE*	1
292	2322520	CASE-MOTOR,STRG HSG, TOP	*55LB* *80LB*	1
	2322521	CASE-MTR, STEER HSG, TOP w/HOLES	*112LB*	1
294	2322525	CASE-MOTOR,STRG HSG,BTM		1
296	2051710	LOCKWASHER-SPLIT, 3MM, ZP	*55LB* *80LB*	2
	2051710	LOCKWASHER-SPLIT, 3MM, ZP	*112LB*	4
298	2043412	SCREW-#8-18 X 3/4 TY AB SS PPH		1
300	✘	LEADWIRE,STEERING MOTOR	*SEE ASSEMBLY CC, DD OR EE*	1
302	2308601	BREATHER FILTER, DR.HOUSING		1
304	2322031	TUBE-OUTPUT, SALTWATER		1
306	2322200	GEAR-OUTPUT		1
308	2327315	BUSHING,ALUMIN. SPACER ST		2
310	2321704	WASHER-THRUST, STEERING		2
312	2321720	SHIM,O-RING		2

▲ Not shown on Parts Diagram.

✘ This part is included in an assembly and cannot be ordered individually.

# PARTS DIAGRAM & PARTS LIST



Item	Part #	Description	Notes	Quantity
314	2321510	COLLAR-DRIVE,BOTTOM		1
316	2324608	O-RING,224,PD PRO STR HSG		2
318	2321515	LINER OUTPUT TUBE		1
320	2324604	O-RING, CASE SEAL		1
322	✘	HOUSING-STEERING, TOP, SW		1
324	2323415	SCREW-#8-32X2.0 SHCS,NYSH		7
326	2322601	PIN-LATCH, SS		1
328	2321702	WASHER-FLAT .375 NYLON		2
330	2263011	E-RING 3/8 DIA. SHAFT		2
332	2322702	SPRING, LATCH PIN SS		2
334	2323411	SCREW-#8-32X.75 SHCS,NYSH		1
336	2327310	BUSHING,STEERING HSG PIVOT,FW		2
338	2321500	DEPTH COLLAR 1.30		1
340	2321702	WASHER-FLAT .375 NYLON		1
342	2260906	KNOB-SOFT GRIP,HG/DR,SS		1
344	2053422	SCREW-M3-.5 X 10 PPH, ZPS	*55LB* *80LB*	2
	2053422	SCREW-M3-.5 X 10 PPH, ZPS	*112LB*	4
346	2327314	BUSHING, PRO STEERING SW		2
348	2320321	WIRE EXTENSION, 112 THRUST MTR	*112LB*	1
350	2325503	DECAL,STOW/DEPLOY,TRV3 PM		1
352	3394602	WASHER-FLAT #8 SS		7

▲ Not shown on Parts Diagram.

✘ This part is included in an assembly and cannot be ordered individually.





RIPTIDE TERROVA MOUNT

Mount Parts Diagram

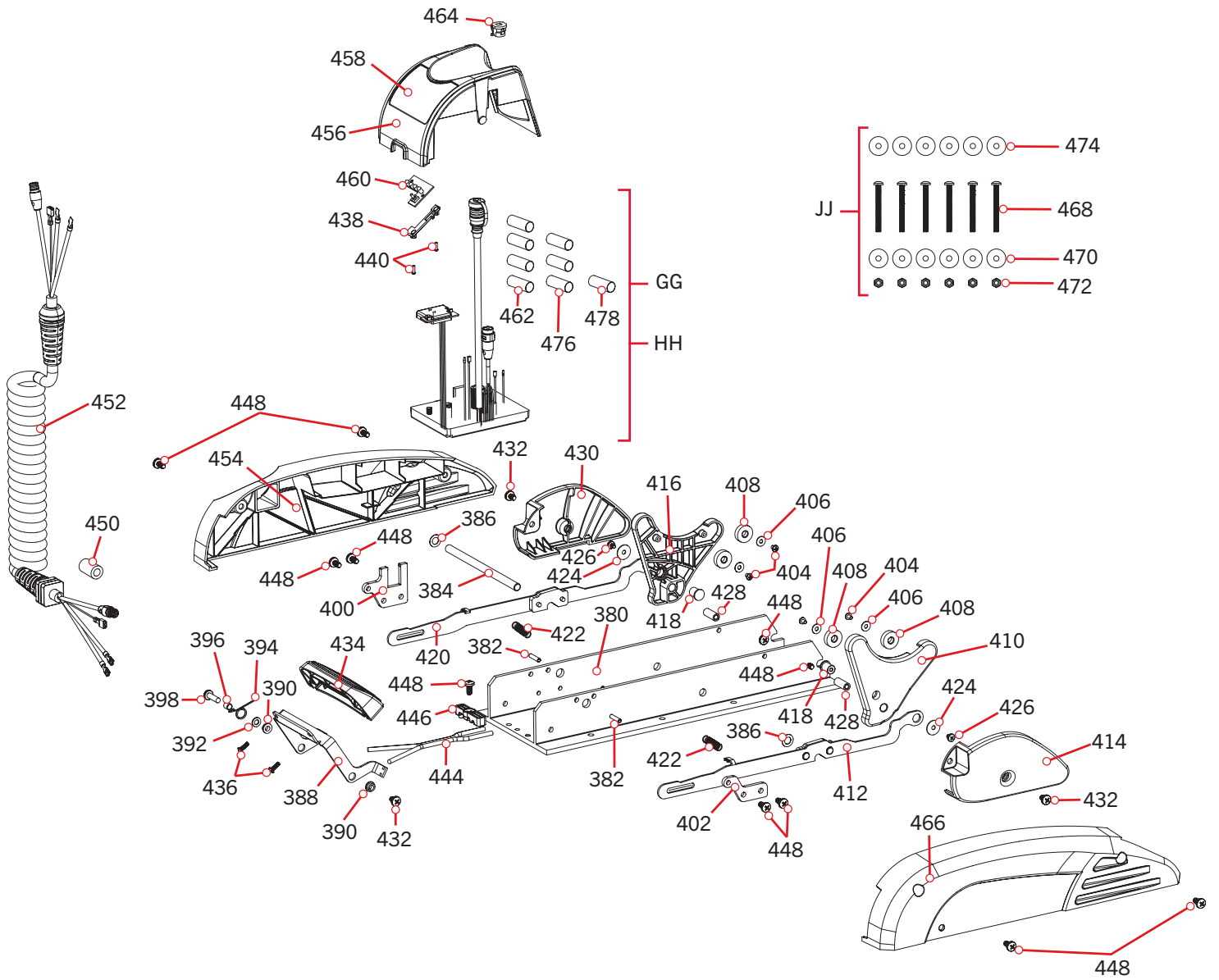

# PARTS DIAGRAM & PARTS LIST

## Mount Parts List

Assembly	Part #	Description	Notes	Quantity
GG	2324062	CONTROL BRD ASY, MAIN, 12V, IP	*55LB*	1
HH	2324063	CTRL BRD,MAIN,24/36V,IP	*80LB* *112LB*	1
JJ	2994864	BAG ASSY-TERROVA/V2,MNTG HDW		1
Item	Part #	Description	Notes	Quantity
380	2321908	BASE, EXTRUSION, MACH,SW		1
382	2322912	PIN-ROLL .1875 X 1.000 SS		2
384	2322603	PIN-PIVOT, SS		1
386	2333100	NUT-SPEED (SS) 3HP-SS		2
388	2320406	HANDLE, RELEASE, SW		1
390	2322604	BUSHING,HANDLE,GOBEIL #FF-310		2
392	2071716	WASHER-FLAT SS .253 x .470		1
394	2322701	SPRING, TORSION		1
396	2301700	SPACER-RELEASE LEVER-BRASS		1
398	2073408	SCREW-1/4-20 X 7/8 PPH S/S		1
400	2321941	BRACKET, STRAIN RELIEF SW		1
402	2321951	BRACKET, SIDEPLATE SW		1
404	2323412	SCREW-#8-18 X .25 PPH SS TY B		4
406	2321706	WASHER-FLAT #8 .50 OD/.188 SS		4
408	2325115	PAD, RUBBER REST, BLACK		4
410	2323910	RAMP-MOTOR, RIGHT 3-5/8"	*55LB*	1
	2323930	RAMP-MOTOR, RIGHT 4"	*80LB*	1
	2323931	RAMP-MOTOR, RIGHT 4.5"	*112LB*	1
412	2994201	ARM/SUPPORT BLOCK ASSY,R,SW		1
414	2321920	PLATE-SKID, RIGHT FW	*55LB* *80LB*	1
	2321922	PLATE-SKID, RIGHT	*112LB*	1
416	2323915	RAMP-MOTOR, LEFT 3 5/8"	*55LB*	1
	2323935	RAMP-MOTOR, LEFT 4"	*80LB*	1
	2323936	RAMP-MOTOR, LEFT 4.5"	*112LB*	1
418	2324706	INSERT-MOTOR RAMP,METAL,SS		2
420	2994203	ARM/SUPPORT BLOCK ASSY,L,SW		1
422	2322716	SPRING, EXTENSION, T2		2
424	2321700	WASHER #10 SS		2
426	2323422	SCREW-#10-24 X .25" PPH SS MCH		2
428	2322921	STAND-OFF, ALUM. ANODIZED		2
430	2321925	PLATE-SKID, LEFT	*55LB* *80LB*	1
	2321927	PLATE-SKID, LEFT	*112LB*	1

▲ Not shown on Parts Diagram.

✳ This part is included in an assembly and cannot be ordered individually.

# PARTS DIAGRAM & PARTS LIST



Item	Part #	Description	Notes	Quantity
432	2323403	SCREW-1/4-20 X.375 MCH SS CRPH		3
434	2320218	COVER, HANDLE COSMETIC SW		1
436	2383446	SCREW-#8-16 X .50" PLASTITE SS		2
438	2320830	LOCKING TAB,PWR/BAT.METER		1
440	2383428	SCREW-#4-24 X 3/8 HI-LO SS		2
444	2090651	LEADWIRE,10 GA		1
446	2321310	STRAIN RELIEF		1
448	2323405	SCREW-1/4-20 X 1/2" MCH SS		11
450	2307312	BEAD-FERRITE		1
452	2991271	COIL CORD ASY 54"/60" NON-US2	*54"* *60"*	1
	2991275	COIL CORD ASY 72" NON-US	*72"*	1
454	2323928	SIDEPLATE-LEFT, RT TERROVA		1
456	2326531	HOUSING-CENTER, RT/ST		1
458	2325637	DECAL-PWR SWTCH,T3PM,SW		1
460	2074080	BATTERY METER, 12V, SW	*55LB*	1
	2074081	BATTERY METER, 24V, SW	*80LB*	1
	2074082	BATTERY METER, 36V, SW	*112LB*	1
462	2305403	SHRINK TUBE-.500 IDX1.0" ADHSV		4
464	2322901	STRAIN RELIEF, HEYCO P/N 1852		1
466	2323923	SIDEPLATE-RIGHT, RT/ TERROVA		1
468	2263462	SCREW-1/4-20 X 2" S/S PPH ADJT		6
470	2261713	WASHER-1/4 FLAT 18-8 SS		6
472	2263103	NUT-1/4-20 NYLOCK SS		6
474	2301720	WASHER-MOUNTING - RUBBER		6
476	2305410	SHRINK TUBE-.315 OD X 2.25"		3
478	2305415	SHRINK TUBE-.472 ID X 2.25"		1
▲	2323406	SCREW-#10-24 X .50 CRPH SS		2
▲	2377179	INSTR.SHEET, MKA-60 STABILIZER	*72"*	1

▲ Not shown on Parts Diagram.

✘ This part is included in an assembly and cannot be ordered individually.



# RECOMMENDED ACCESSORIES

## › ON-BOARD & PORTABLE BATTERY CHARGERS

Stop buying new batteries and start taking care of the ones you've got. Many chargers can actually damage your battery over time – creating shorter run times and shorter overall life. Digitally controlled Minn Kota chargers are designed to provide the fastest charge that protect and extend battery life.



MK212PCL



MK210D



MK110PD

## › TALON SHALLOW WATER ANCHOR

Talon is the only shallow water anchor with up to 15' of anchoring depth, multiple anchoring modes, and control from the bow, transom, console, remote or mobile device.



### BUILT-IN WORK LIGHT

Lets you tie lines and work from the transom any time of day — or night. Includes both white and blue LED lights with three brightness settings.



### BLUETOOTH® CONNECTIVITY

Lets you control Talon from your mobile device and easily update it. Also opens up communication to other control options.



### UP TO 15' DEEP

Control more water and catch more fish with the first 15' shallow water anchor.



### MORE CONTROL OPTIONS

- Control Panel
- Wireless Remote
- Mobile App
- Wireless Foot Switch
- Humminbird® Connectivity
- Advanced GPS Navigation System Remote



## › MINN KOTA ACCESSORIES

We offer a wide variety of trolling motor accessories, including:

- 60-Amp Circuit Breaker
- Mounting Brackets
- Stabilizer Kits
- Extension Handles
- Battery Connectors
- Battery Boxes
- Quick Connect Plugs

