

# USING & ADJUSTING THE MOTOR

## MOUNT FEATURES

Become familiar with the features of the motor to maximize the capabilities this product offers.

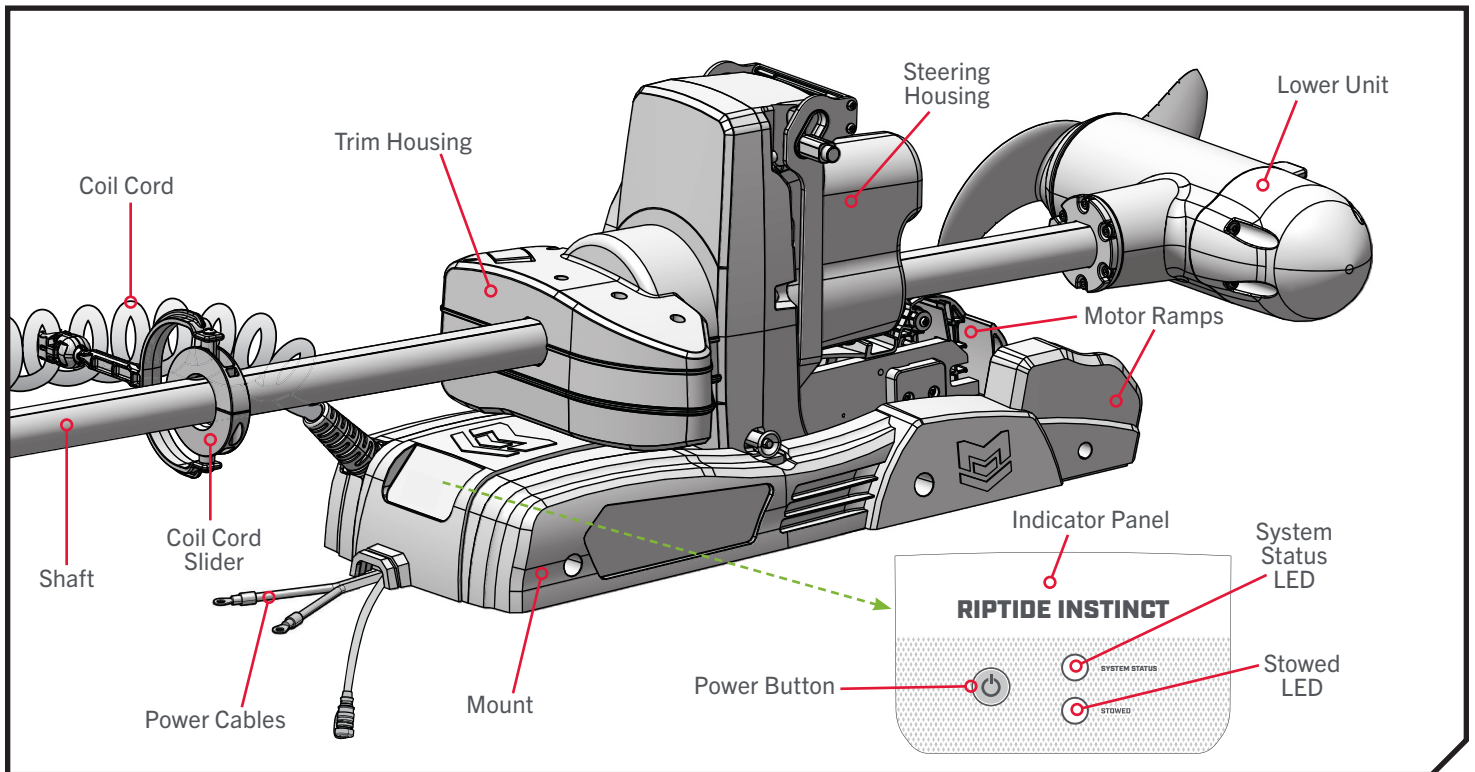

### › Mount

The Mount holds the motor on the deck of the boat. The Mount positions the motor when deployed and secures the motor flat on the deck when stowed. The Indicator Panel is located on the end of the Mount, near the Power Cables.

### › Motor Ramps

The Motor Ramps hold and support the Lower Unit when the motor is stowed. When the Lower Unit rests securely on the Motor Ramps, the **STOWED** LED on the Indicator Panel will illuminate orange. The Motor Ramps also hold the motor in the deployed position.

**⚠ WARNING**

When stowing or deploying the motor, keep fingers clear of all hinges, pivot points, pinch points and all moving parts.

### › Coil Cord Slider

Motors with a shaft length of 72", 87", or 100" have a Coil Cord Slider. The Coil Cord Slider functions to support the Coil Cord and prevent it from becoming tangled or hitting obstructions. The Coil Cord Slider sits on the Shaft between the Control Head and Trim Housing. The arm of the Coil Cord Slider connects to the Coil Cord. The Coil Cord Slider floats freely on the shaft and moves with the Coil Cord while stowing and deploying. The Coil Cord Slider is not present on motors with a shaft length of 60".

# INDICATOR PANEL

## ⚠️ WARNING

When transporting the motor, it is important to always stow the motor and ensure the Lower Unit is securely placed on the Motor Ramps. The STOWED LED on the Indicator Panel must illuminate orange to indicate a secure stow. A secure stow holds the motor in place during transportation when it is subject to high levels of shock and vibration. Failure to securely stow the motor may result in injury or damage to the unit.

## ⚠️ CAUTION

Ensure that the Power button is turned off when the motor is not in use. For safety reasons, disconnect the motor from the batteries when the motor is not in use or while the batteries are charging. If the motor control is left on and the Prop rotation is blocked, severe motor damage can result.

## INDICATOR PANEL

The Indicator Panel is located on the end of the Mount, by the Power Cables. Power to the motor is turned "on" and "off" through the Power button on the Indicator Panel. The LEDs on the Indicator Panel communicate the status of the motor.

### › Power Button

On the Indicator Panel, press the Power button once to turn the motor "on." When the motor is powered on, the System Status LED will illuminate blue. To turn the motor "off," press and release the Power button. When the motor is powered off, the System Status LED will not be illuminated. The Riptide Instinct QUEST has an auto-shutoff and will automatically power off after 90 minutes of inactivity in the stowed position.

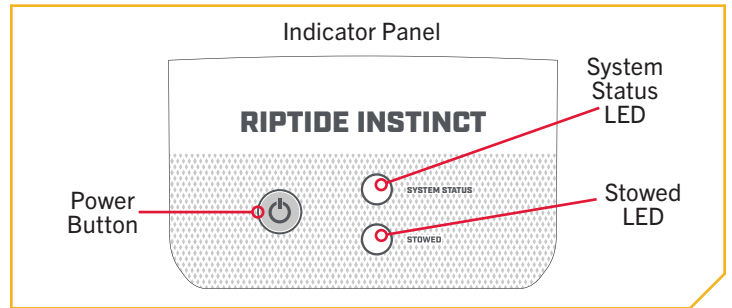

### › LED Patterns

#### STOWED

- **Orange solid** - Indicates that the trolling motor is stowed and the Lower Unit is resting securely on the Motor Ramps. When the Lower Unit is off of the Motor Ramps, the STOWED LED will not be illuminated.

#### SYSTEM STATUS

- **Blue solid** - Normal operation. The trolling motor is powered on. When the Motor is powered off, the System Status LED will not be illuminated.
- **Red flashing** - Critical error. The Prop will lock and cannot be engaged. A critical error must be manually cleared by correcting the source of the error. Once fixed, cycle power to the trolling motor by pressing the Power button "off" and then back "on" to clear the error and resume normal operation.

## ⚠️ WARNING

The trolling motor is not safely stowed for transport until the orange STOWED LED is illuminated.

**NOTICE:** When encountering a critical error, the Wireless Remote will provide an error code in the Diagnostics menu. Refer to the Wireless Remote Owner's Manual to learn more about error codes.

# STOWING AND DEPLOYING THE RIPTIDE INSTINCT QUEST

## STOWING AND DEPLOYING THE RIPTIDE INSTINCT QUEST





The Riptide Instinct™ QUEST™ gives you push-button command from anywhere on the boat. Stow, deploy or trim the motor up and down by using the buttons on your Advanced GPS Navigation Wireless Remote, Foot Pedal, One-Boat Network app, or a connected Humminbird® fish finder. It's instant. Effortless. And it makes Riptide Instinct QUEST the easiest-to-use motor on the water.



Use the following procedures to stow and deploy the motor. If the motor stalls when attempting to stow, the motor may be encountering an error. Check for obstructions or low motor batteries. If the batteries are too low to fully stow the motor, re-engage power, deploy the motor, trim the lower unit to its highest setting, and turn power off until batteries can be recharged. Once batteries are charged, attempt to stow the motor again.

### STOW & DEPLOY >

## STOWING AND DEPLOYING WITH THE WIRELESS REMOTE

### > Deploying with the Wireless Remote

- 1 a. Press the Power  button on the Wireless Remote.
- b. Use the Speed Up  or Speed Down  button to find Instinct.
- c. Press the Steer Right  button to select Instinct and open Deployment Mode.

**NOTICE:** Alternatively, press the One-Boat Network  side button to quickly access Deployment Mode. The function of the OBN  side button is set by default to open the Instinct Deployment Mode menu.

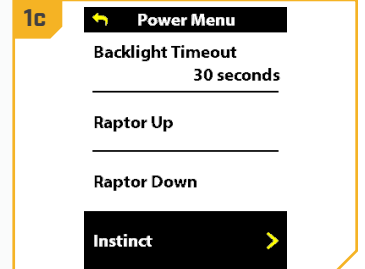
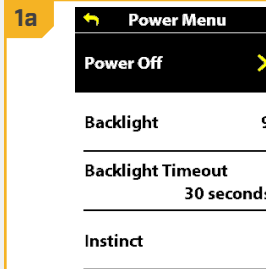

**NOTICE:** The Wireless Remote comes from the factory paired to the Riptide Instinct QUEST.

# STOWING WITH THE WIRELESS REMOTE

2

- d. Press the Steer Right button to select Deploy. The motor will automatically deploy.

## WARNING

As soon as Deploy is selected, the motor will automatically deploy. Be sure that the motor is clear from obstructions and has a clear path of travel. The Prop is disabled while the motor is stowing or deploying to prevent accidental contact with the rotating Prop.

- e. While the Motor is deploying, it is possible to pause the action. To pause the action, press the Steer Right button to select Pause.
- f. To resume the Deploy action, press the Steer Right button to select Deploy.
- g. If the Motor continues, it will complete the deploy process and normal motor operation will follow.

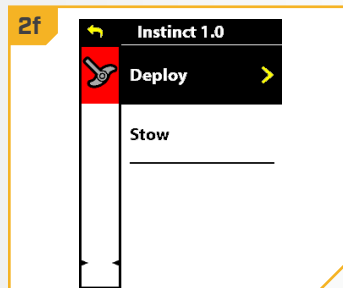
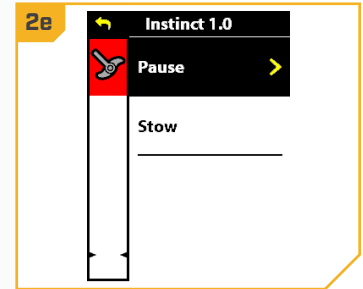
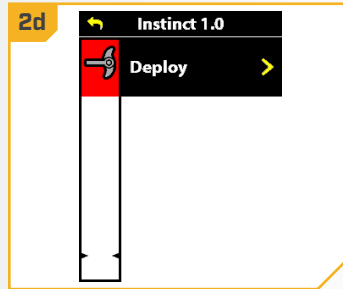

**NOTICE:** To avoid churning or agitation of surface water, ensure that the top of the motor is submerged at least 12" below the surface of the water.

## Stowing with the Wireless Remote

1

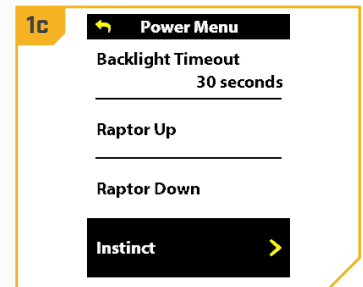
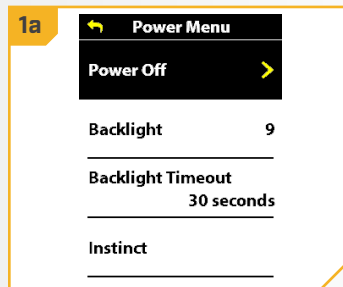

- a. Press the Power button on the Wireless Remote.
- b. Use the Speed Up or Speed Down button to find Instinct.
- c. Press the Steer Right button to select Instinct and open Deployment Mode.

**NOTICE:** Alternatively, press the One-Boat Network side button to quickly access Deployment Mode. The function of the OBN side button is set by default to open the Instinct Deployment Mode menu.





# STOWING WITH THE WIRELESS REMOTE

2

- d. Use the Speed Up  or Speed Down  button to find Stow. Use the Steer Right  button to select it. Once selected, the motor will automatically stow, and the Prop will be disabled.

## WARNING

As soon as Stow is selected, the motor will automatically stow. Be sure the motor is clear from obstructions and has a clear path of travel. The Prop is disabled while the motor is stowing or deploying to prevent accidental contact with the rotating Prop.

- e. While the Motor is stowing, it is possible to pause the action. To pause the action, press the Speed Down  button to find Pause and press the Steer Right  button to select it.
- f. To resume the Stow action, press the Steer Right  button to select Stow.
- g. If the Motor continues, it will complete the Stow process and normal motor operation will follow.

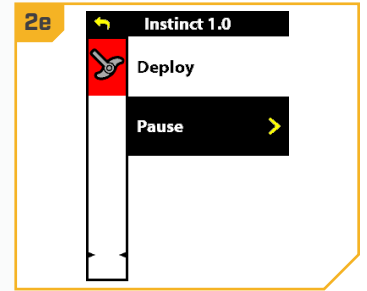
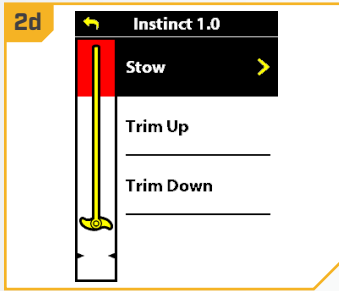

**NOTICE:** The Stow option is only displayed when the motor is deployed.

## WARNING

The motor is not safely stowed for transport until the orange STOWED  LED on the Indicator Panel is illuminated.

# DEPLOYING WITH THE OBN APP

## STOWING AND DEPLOYING WITH THE ONE-BOAT NETWORK (OBN) APP

### Deploying with the OBN App

1

- a. Open the One-Boat Network (OBN) app on the mobile device. Make sure the mobile device is paired with the trolling motor.
- b. From the OBN home screen, tap the Motor menu. The Motor menu opens the Motor home screen.
- c. Before the Motor home screen will open, tap Agree on the on-screen prompt.

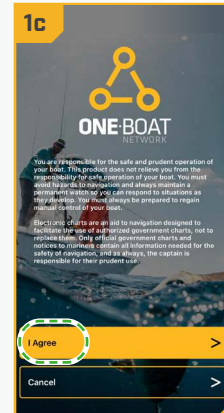
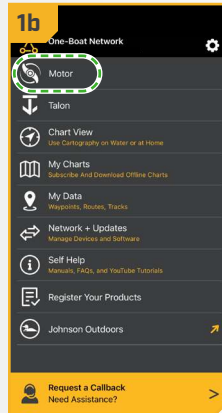

**NOTICE:** The on-screen prompt will only display once each time the app is launched. If the prompt has displayed, the Motor home screen appears after.

2

- d. Tap Trim/Stow on the bottom of the screen to open the Trim/Stow/Deploy menu.
- e. Tap Deploy to automatically deploy the motor. Normal motor operation will follow.

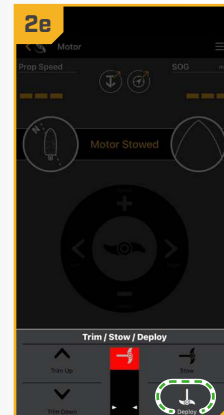
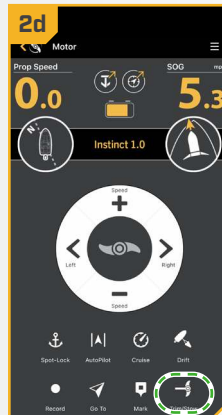

### WARNING

As soon as Deploy is tapped, the motor will automatically deploy. Be sure that the motor is clear from obstructions and has a clear path of travel. The Prop is disabled while the motor is stowing or deploying to prevent accidental contact with the rotating Prop.

**NOTICE:** While the motor is deploying, it is possible to stop the action by tapping Pause. To resume, tap the desired action.

**NOTICE:** To avoid churning or agitation of surface water, ensure that the top of the motor is submerged at least 12" below the surface of the water.

## › Stowing with the OBN App

1

- a. Open the One-Boat Network (OBN) app on the mobile device. Make sure the mobile device is paired with the trolling motor.
- b. From the OBN home screen, tap the Motor menu. The Motor menu opens the Motor home screen.
- c. Before the Motor home screen will open, tap Agree on the on-screen prompt.

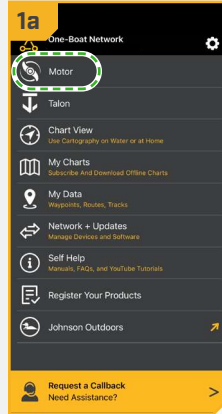

**NOTICE:** The on-screen prompt will only display once each time the app is launched. If the prompt has displayed, the Motor home screen appears after.

2

- d. Tap Trim/Stow on the bottom of the screen to open the Trim/Stow/Deploy menu.
- e. Tap Stow to automatically stow the motor. The Prop will be disabled and "Motor Stowed" will display on the screen.

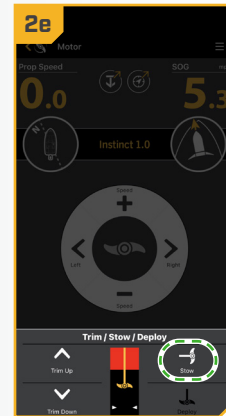
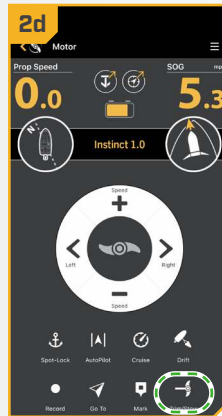

### WARNING

As soon as Stow is tapped, the motor will automatically stow. Be sure the motor is clear from obstructions and has a clear path of travel. The Prop is disabled while the motor is stowing or deploying to prevent accidental contact with the rotating Prop.

**NOTICE:** While the motor is stowing, it is possible to stop the action by tapping Pause. To resume, tap the desired action.

### WARNING

The motor is not safely stowed for transport until the orange STOWED LED on the Indicator Panel is illuminated.

# ADJUSTING THE DEPTH (TRIM) OF THE RIPTIDE INSTINCT QUEST

## ADJUSTING THE DEPTH (TRIM) OF THE RIPTIDE INSTINCT QUEST

Once the boat is on the water, it may be necessary to adjust the trim of the Lower Unit up or down to achieve an optimum depth for motor performance. When setting the depth of the motor, be sure the top of the Lower Unit is submerged at least 12" below the surface of the water to avoid churning or agitation of surface water. It may be necessary to trim the motor up or down, depending on how the boat is responding. Trim up to avoid hitting underwater objects and trim down if the Prop is coming out of the water.

The Prop will temporarily stop while trimming the motor and resume once trimming is stopped. The motor is programmed to operate safely and limit Prop rotation when the Lower Unit is trimmed within certain limits. Trim limits are in place to avoid damage to the unit. A Lower Trim Limit is set approximately 3" from the bottom of the Control Head to the top of the Trim Housing. An Upper Trim Limit is set 13 1/2" from the bottom of the Mount to the center of the Lower Unit. A Prop Lockout Region, defined as 16" from the bottom of the Mount to the center of the Lower Unit, is used to eliminate the possibility of the motor contacting the boat hull. All functions, except for manual steering and recording an iTrack, are canceled upon trimming into this region.

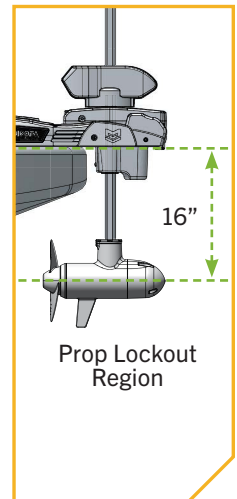
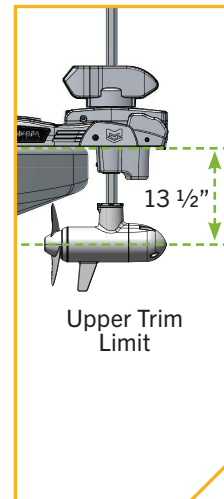
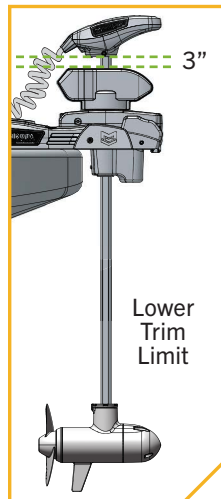
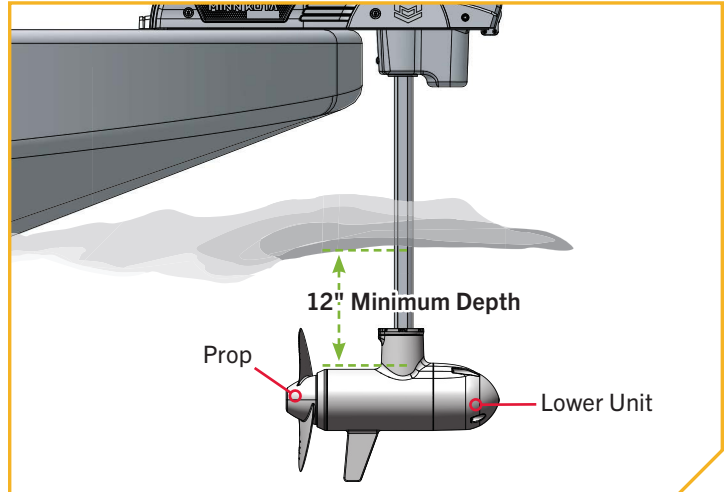

## ▶ Trimming with the Wireless Remote

- 1 a. Press the Power button on the Wireless Remote.
- b. Use the Speed Up or Speed Down button to find Instinct.
- c. Press the Steer Right button to select Instinct and open Deployment Mode.

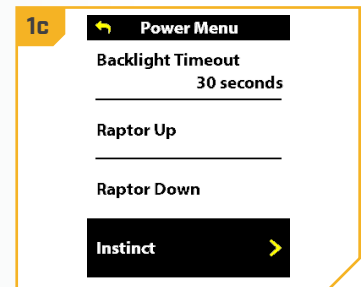
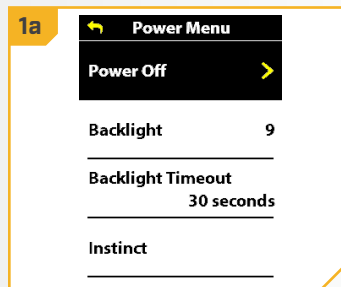

**NOTICE:** Alternatively, press the One-Boat Network side button to quickly access Deployment Mode. The function of the OBN side button is set by default to open the Instinct Deployment Mode menu.





# TRIMMING WITH THE WIRELESS REMOTE

2

- d. Once in Instinct Menu, use the Speed Up  or Speed Down  button to select Trim Up or Trim Down. Trimming up will raise the motor and trimming down will lower the motor.
- e. Press and hold the Steer Right  button to select it.
- f. When the motor has reached its highest trim limit, the Prop will be locked out and the Trim Up option will be disabled. The Prop will stay locked out even when the Deployment Menu has closed. Trim the motor down and out of the Prop Lockout region to restore functionality.
- g. When the lower trim limit is reached, the Trim Down option will be disabled.

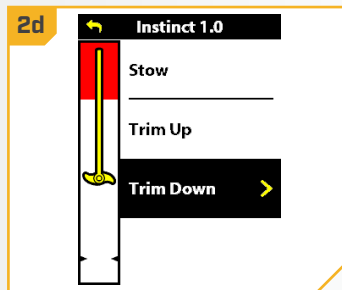
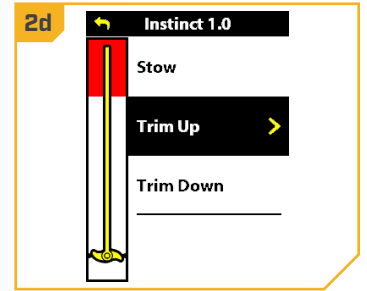
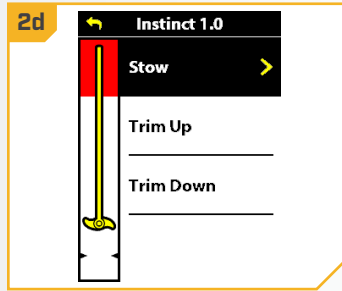

## WARNING

While Trim Up or Trim Down is pressed, the motor will automatically trim. Be sure the motor is clear from obstructions and has a clear path of travel. The Prop is disabled while the motor is being trimmed to prevent accidental contact with the rotating Prop.

## WARNING

When trimming the motor, keep fingers clear of all hinges, pivot points and all moving parts.

**NOTICE:** To avoid churning or agitation of surface water, ensure that the top of the motor is submerged at least 12" below the surface of the water.

**NOTICE:** The red area is the Prop Lockout region. The Prop will be automatically disabled if the lower unit is trimmed into this zone, and the Prop icon will turn gray. To restore Prop functionality, trim the lower unit out of the Prop Lockout region.



# TRIMMING WITH THE OBN APP

## ▶ Trimming with the OBN App

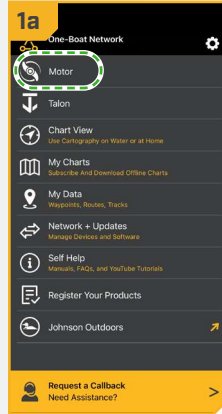

1

- Open the One-Boat Network (OBN) app on the mobile device. Make sure the mobile device is paired with the trolling motor.
- From the OBN home screen, tap the Motor menu. The Motor menu opens the Motor home screen.
- Before the Motor home screen will open, tap Agree on the on-screen prompt.



**NOTICE:** The on-screen prompt will only display once each time the app is launched. If the prompt has displayed, the Motor home screen appears after.

2

- Tap Trim/Stow on the bottom of the screen to open the Trim/Stow/Deploy menu.
- To trim the motor up, press and hold Trim Up . Continue to hold until the lower unit is at the desired height.
- To trim the motor down, press and hold Trim Down . Continue to hold until the lower unit is at the desired height.

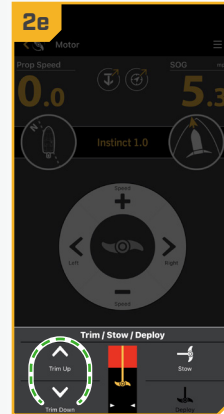
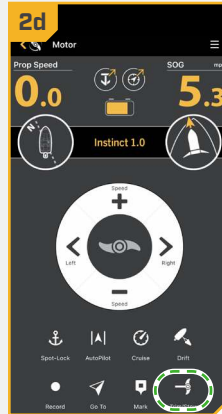

### **WARNING**

While Trim Up or Trim Down is pressed, the motor will automatically trim. Be sure the motor is clear from obstructions and has a clear path of travel. The Prop is disabled while the motor is being trimmed to prevent accidental contact with the rotating Prop.

### **WARNING**

When trimming the motor, keep fingers clear of all hinges, pivot points and all moving parts.

**NOTICE:** The red area is the Prop Lockout region. The Prop will be automatically disabled if the lower unit is trimmed into this zone, and the Prop icon will turn gray. To restore Prop functionality, trim the lower unit out of the Prop Lockout region.



**NOTICE:** To avoid churning or agitation of surface water, ensure that the top of the motor is submerged at least 12" below the surface of the water.

## MOTOR ADJUSTMENTS >

### > Adjusting the Lift Belt

The Lift Belt assists in trimming the Lower Unit up and down. Slack may appear periodically in the Lift Belt along the Shaft of the motor. To maintain tension on the Lift Belt, the screw that holds tension on the Lift Belt may occasionally require small adjustments.

1

- a. Place the motor in the stowed position. Once stowed, turn the motor off.



## WARNING

Disconnect the motor from power to avoid accidental operation.

- b. Locate the Socket Head Cap Screw on the bottom of the Control Head, between the Coil Cord and Shaft. Adjust this Screw to increase tension on the Lift Belt.
- c. Using a 5/32" Allen Wrench, turn the Socket Head Cap Screw clockwise to tighten the Lift Belt. Tighten to 8–10 in-lb.

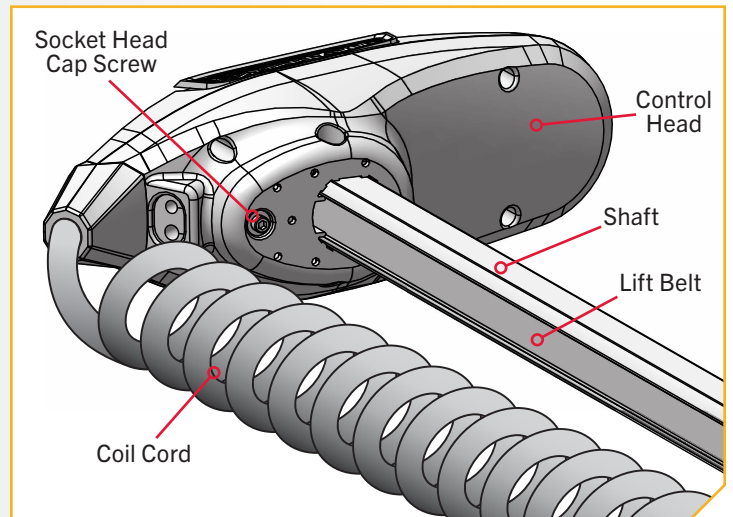

# MOTOR ADJUSTMENTS

## › Greasing the Tilt Shaft and Latch Pin

To maintain optimum performance of the Riptide Instinct QUEST, it is recommended that the Tilt Shaft and Latch Pin be greased every season. Minn Kota recommends using a marine-grade grease.

**1**

- a. Deploy the motor. Once deployed, turn the motor off.

### **WARNING**

Disconnect the motor from power to avoid accidental operation.

- b. Locate the Tilt Shaft near the center of the Mount, in the space between the Mount and Steering Housing.
- c. Apply a marine-grade grease to the exposed threads of the Tilt Shaft. Apply the grease sparingly.

**NOTICE:** Ensure that the space between the Mount and Steering Housing is clean and free of debris. The Mount has a Stow Pad that contacts the Steering Housing when stowed. The motor cannot stow securely if an obstruction is present on the Stow Pad.

**1c**

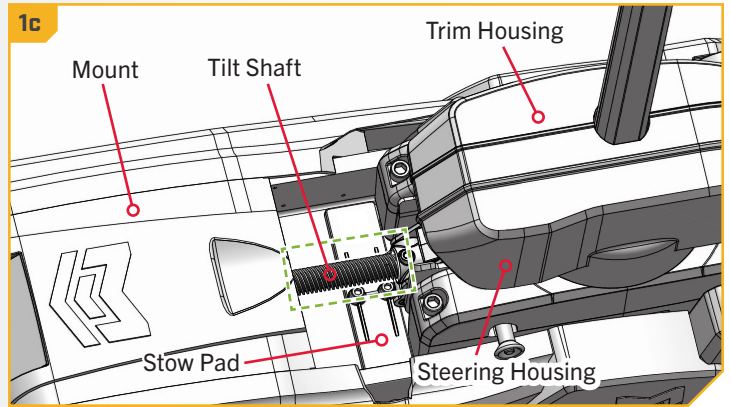

### **CAUTION**

When stowing and deploying the motor, keep fingers clear of all hinges, pivot points and all moving parts.

**2**

- d. Reconnect power to the motor. Turn the motor “on.”
- e. Stow the motor. Once stowed, turn the motor off.

### **WARNING**

Disconnect the motor from power to avoid accidental operation.

- f. Locate the Latch Pin at the bottom of the Steering Housing. The Latch Pin is part of the Latch Bracket Handle.
- g. Apply marine-grade grease to both ends of the Latch Pin to maintain optimal performance. Apply the grease sparingly to both ends of the Latch Pin where the Latch Pin contacts the Latch Bracket Handle.

### **CAUTION**

Do not engage the Latch Bracket Handle while greasing the Latch Pin to avoid pinch points.

**2g**

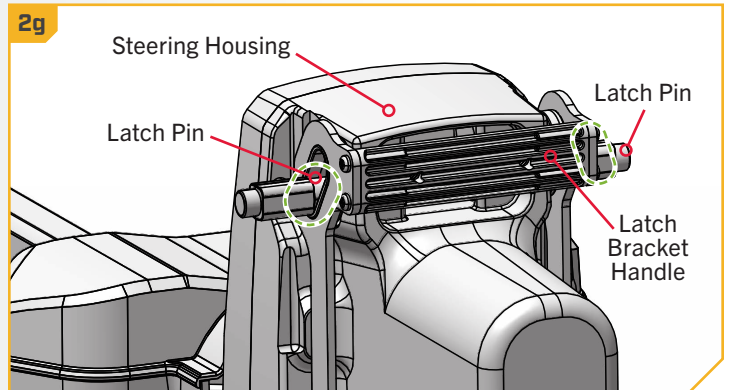

### **CAUTION**

When stowing and deploying the motor, keep fingers clear of all hinges, pivot points and all moving parts.

## › Installing an External Transducer

An external transducer is not included with your trolling motor. An external transducer can be installed onto motors that have Advanced GPS Navigation.

**1**

- a. Mount the External Transducer according to directions provided with the transducer.
- b. Leave enough slack in the Transducer Cable between the Lower Unit and Control Head to allow the motor to properly stow and deploy.
- c. Use two tie wrap cables to secure the Transducer Cable to the Shaft just above the Lower Unit and just below the Control Head.
- d. Run the Transducer Cable through the Coil Cord to the power supply.

### **⚠ CAUTION**

Failure to follow the recommended wire routing for the Sonar and External Transducer Cables may cause damage to the product and void your product warranty. Take care to test the length and placement of all cables to ensure that there is enough slack where needed and that cables are free of entanglement by moving parts. Routing the cables in any way other than as directed may cause damage to the cables via pinching or severing.

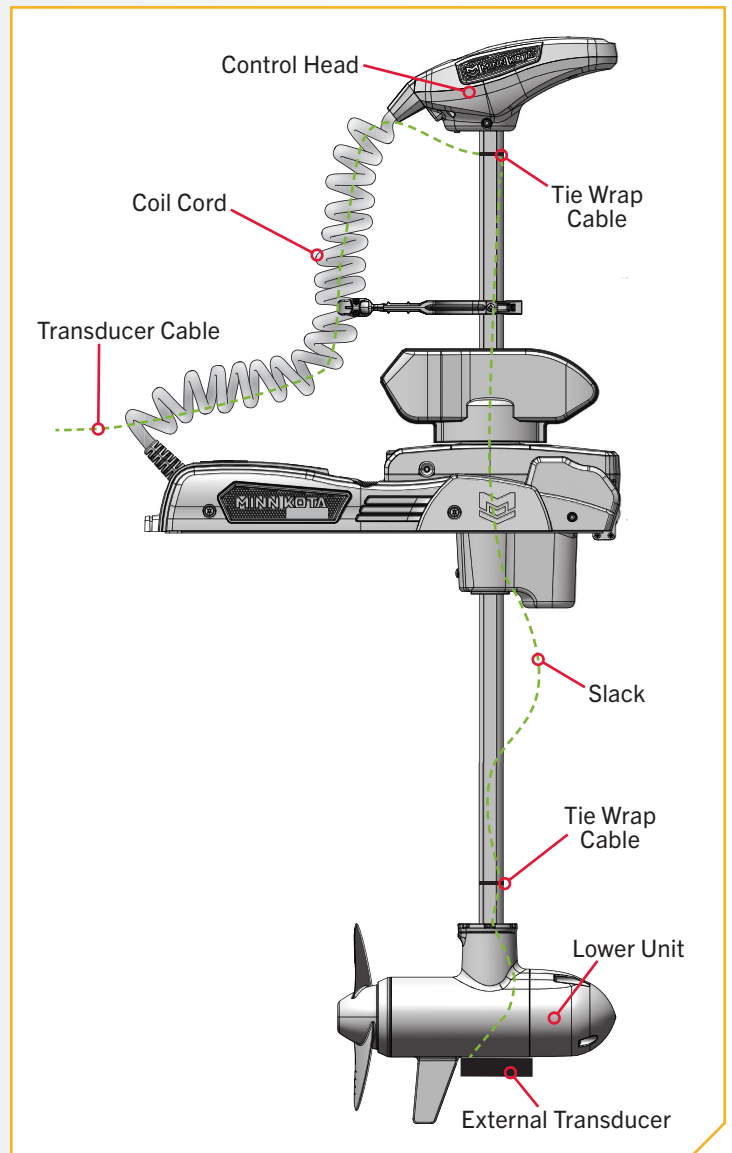

# EMERGENCY STOW PROCEDURES

## EMERGENCY STOW PROCEDURES >

In the unlikely event that the motor will not stow from the Wireless Remote or One-Boat Network app, the following alternative stow methods can be used to resolve the issue.

**NOTICE:** If the motor stalls when attempting to stow, the motor may be encountering an error. Check for obstructions or low motor batteries. If the batteries are too low to fully stow the motor, re-engage power, deploy the motor, trim the lower unit to its highest setting, and turn power off until batteries can be recharged. Once batteries are charged, attempt to stow the motor again.



## > Stowing from the Mount

In the unlikely event the Wireless Remote or One-Boat Network app becomes non-functioning, the motor can be stowed from the Indicator Panel at the base of the Mount.

1

### **WARNING**

During this procedure, the motor will go into an automated sequence. Keep fingers clear of all hinges, pivot points and all moving parts. Ensure that the motor or parts of the motor do not contact the boat, trailer, persons, or any other obstruction.

- a. Locate the Indicator Panel at the base of the Mount.
- b. Ensure that the motor is powered “on” by checking that the System Status  LED is illuminated blue.
- c. Press and hold the Power  button for 10 seconds.
- d. The blue and orange LEDs next to the System Status (blue) and Stowed (orange) Indicators will flash alternately, and the motor will begin to stow.

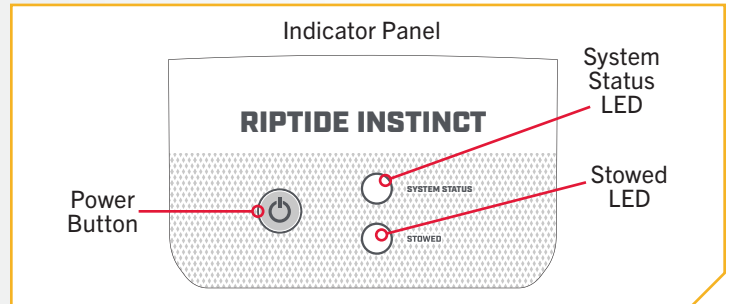

## MANUAL STOW BYPASS

If the motor loses power or will not stow by any other method, a Manual Stow Bypass procedure can be used to manually stow the motor. The Manual Stow Bypass involves two steps:

1. Manually Trim the Motor
2. Manually Stow the Motor

After completing both steps of the Manual Stow Bypass, return to shore and resolve the error or take the motor to a Minn Kota authorized service provider. Once the error has been resolved, see the “Manual Stow Bypass Recovery” section for instructions on restoring motor functions after an emergency stow.



Scan to find additional help.

## **WARNING**

While servicing the motor, stay clear of pinch points and do not wear loose-fitting clothing or loose-fitting jewelry.

## **CAUTION**

Once the motor has been manually stowed, it will be non-operational until it is manually recovered.

**NOTICE:** In the event of a Manual Stow Bypass, the Quick Release Pin is removed from the Steering Housing. To reinstall the Quick Release Pin and restore motor functions, the Steering Housing must be in the same position it was in when the Quick Release Pin was removed. Incorrect installation of the Quick Release Pin may cause severe damage to the motor. See the “Manual Stow Bypass Recovery” section for more information.

## › Manually Trim the Motor

1

## **WARNING**

Disconnect the motor from power to avoid accidental operation.

- a. With the motor deployed, locate the Trim Release Lever on the side of the Trim Housing.
- b. Firmly grasp the Shaft of the motor. While lifting up on the Shaft, open the Trim Release Lever.
- c. Manually trim the motor by pulling the Shaft upward. Stop lifting when there are approximately 10 inches of Shaft remaining below the Steering Housing.
- d. Rotate the Shaft so that the Prop faces Port. The Lower Unit should be perpendicular to the Mount.
- e. Close the Trim Release Lever to secure the Shaft in place.

## **WARNING**

Moving parts can cut or crush. When using the Trim Release Lever or moving the Shaft, keep fingers clear of all hinges, pivot points, and moving parts. Take care when mechanical parts are in motion.

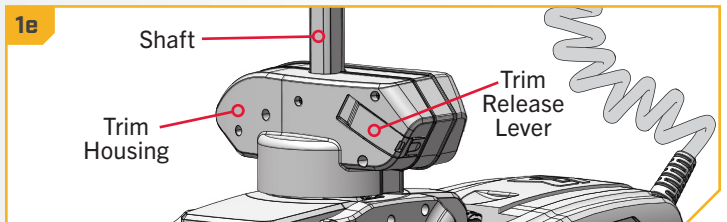
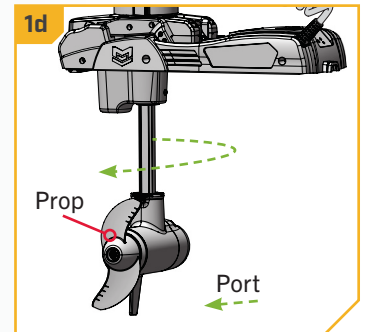
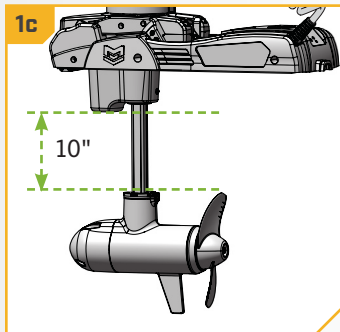
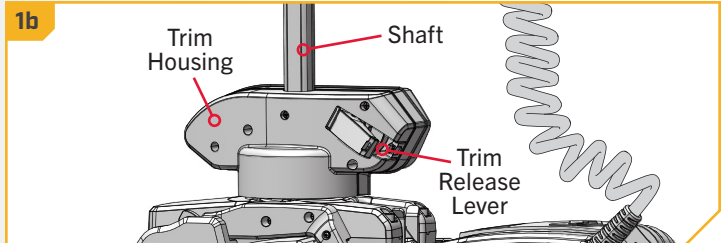

# MANUAL STOW BYPASS

## Manually Stow the Motor

1

**NOTICE:** Complete the Manual Trim before beginning this procedure.

- a. Locate the Quick Release Lever on the Steering Housing, above the Tilt Shaft near the center of the Mount. Open the Quick Release Lever by lifting upward.
- b. Locate the Quick Release Pin on the side of the Steering Housing. Push in the center of the Pin. While keeping the center of the Pin pushed in, pull the Pin completely out of the Steering Housing.

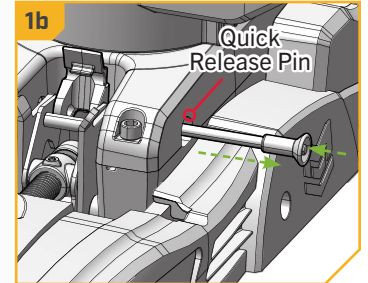
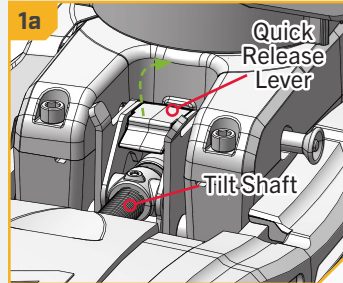

**NOTICE:** Do not lose the Quick Release Pin. The Motor cannot function without the Quick Release Pin.

- c. Locate the Latch Bracket Handle on the back of the Steering Housing, near the Motor Ramps.
- d. Firmly grasp the Shaft and raise the Latch Bracket Handle. While holding both the Shaft and Latch Bracket Handle, pivot the trolling motor into the stowed position.

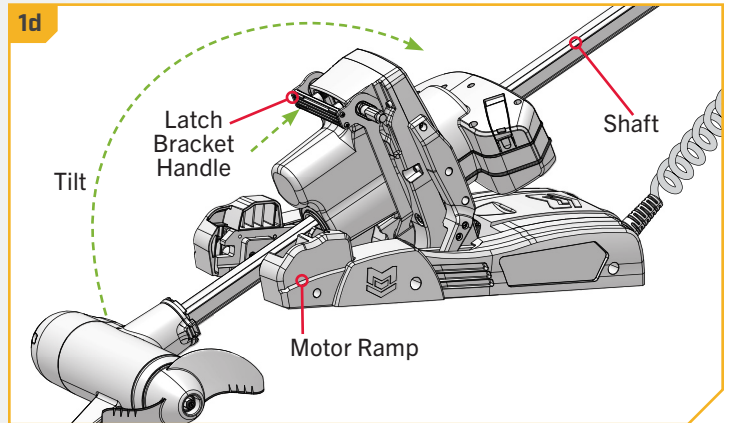

2

- e. With the motor in the stowed position, release the Latch Bracket Handle while maintaining a hold on the Shaft.
- f. Locate the Trim Release Lever on the side of the Trim Housing. While holding the Shaft, open the Trim Release Lever.
- g. Pull the Lower Unit fully onto the Motor Ramps. Secure the lower unit on the Motor Ramps and close the Trim Release Lever to lock the motor in the stowed position.

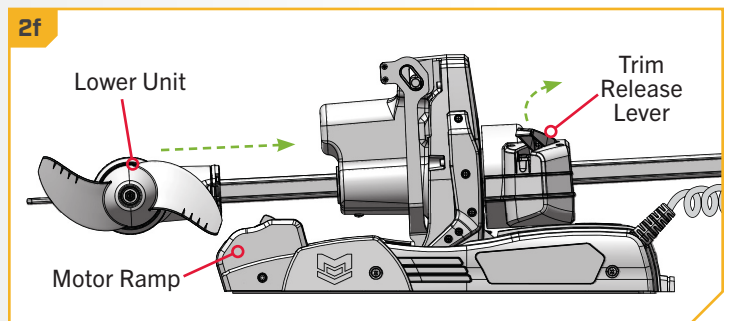

**NOTICE:** Once on shore, take the motor to an Authorized Service Provider or use the Minn Kota Help Center at [minnkota.johnsonoutdoors.com](http://minnkota.johnsonoutdoors.com).

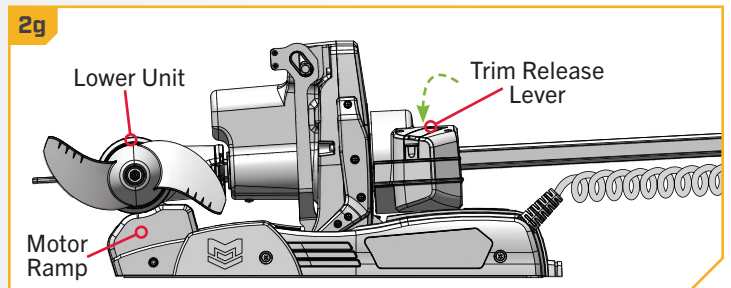



# MANUAL STOW BYPASS RECOVERY

## MANUAL STOW BYPASS RECOVERY

After completing a Manual Stow Bypass, most motor functions are disabled, and an error will display on the Wireless Remote. If the error that required an emergency stow is resolved, motor operation can be restored through a Manual Stow Bypass Recovery procedure. To recover from a Manual Stow Bypass, the motor must be manually deployed and the Quick Release Pin reinstalled.

### CAUTION

Once the motor has been manually stowed, it will be non-operational until the Manual Stow Bypass is recovered.

1

### WARNING

Disconnect the motor from power to avoid accidental operation.

- With the motor powered "off" and in the stowed position, locate the Trim Release Lever on the side of the Trim Housing. Firmly grasp the Shaft and open the Trim Release Lever.
- While holding the Shaft, slide the Lower Unit approximately 10 inches Outboard. Keep the Shaft horizontal to prevent the motor from tilting. When the Lower Unit is clear of the Motor Ramps, close the Trim Release Lever to lock the Shaft.
- While holding the Shaft and Steering Housing, pivot the motor into the deployed position. Guide the motor upright until the Latch Pin fully engages with the Motor Ramps.

### WARNING

Moving parts can cut or crush. Keep fingers clear of all hinges, pivot points, and moving parts when using the Trim Release Lever, moving the Shaft, or tilting the motor. Take care when mechanical parts are in motion.

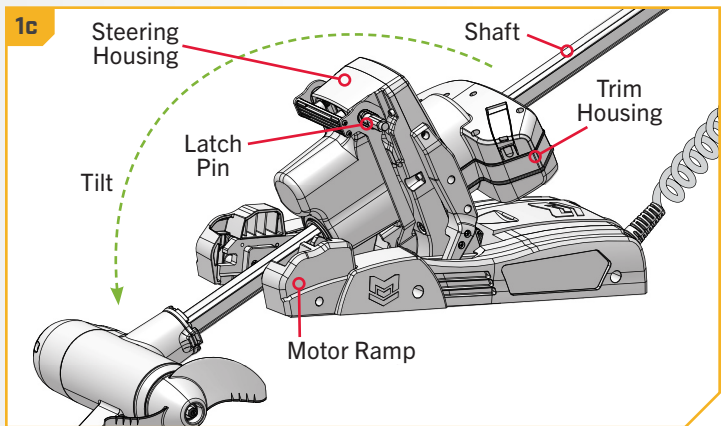
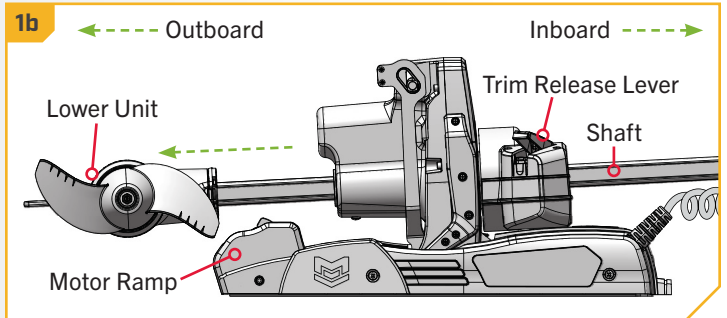

# MANUAL STOW BYPASS RECOVERY

2

- d. Take the Quick Release Pin that was removed during the Manual Stow Bypass.
- e. Locate the hole for the Quick Release Pin on the Port side of the Steering Housing.
- f. The Quick Release Pin must pass through four center plates between the Steering Housing to properly install. If the holes in the plates are not aligned, pull the Quick Release Lever to lift the plates. Realign the plates as needed to allow the Quick Release Pin to be completely inserted.
- g. Press and hold in the center of the Quick Release Pin. While pressing the center of the Pin, insert the Quick Release Pin into the Steering Housing. Ensure that the Quick Release Pin passes through all four plates and into the other side of the Steering Housing. The Quick Release Pin is fully inserted when the handle is seated against the Steering Housing. The retaining ball in the Quick Release Pin must be visible past the final plate.

**NOTICE:** If the Quick Release Pin is installed incorrectly and does not capture all four plates, severe motor damage may occur.

- h. With the Quick Release Pin fully inserted, lower the Quick Release Lever. Ensure the Lever is seated.

## ⚠ CAUTION

Watch for pinch points when closing the Quick Release Lever. Push on the back of the Quick Release Lever with an open palm to keep fingers clear of pinch points.

- i. Reconnect the motor to power. Normal motor operation may resume.

**NOTICE:** The Quick Release Pin must be fully inserted for the motor to function.

**NOTICE:** If the motor is nonfunctional after restoring power and reinstalling the Quick Release Pin, contact a Minn Kota authorized service provider.

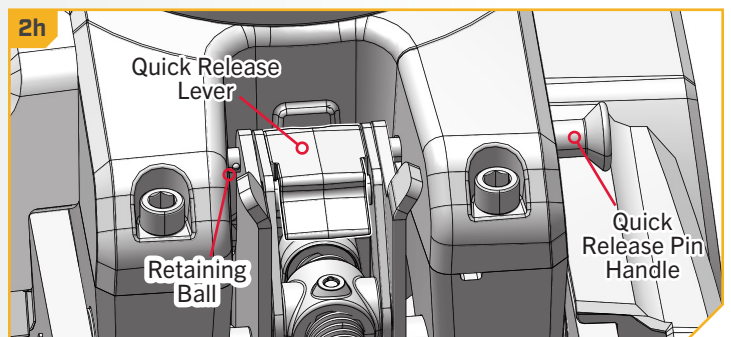
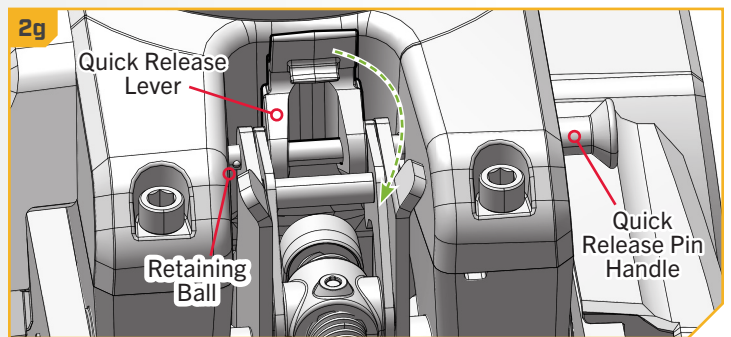
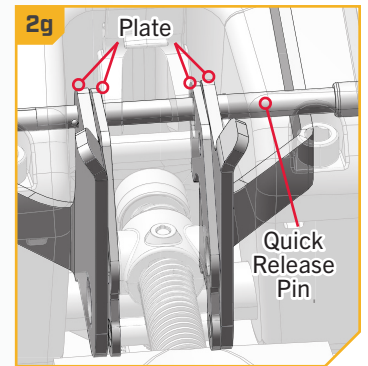
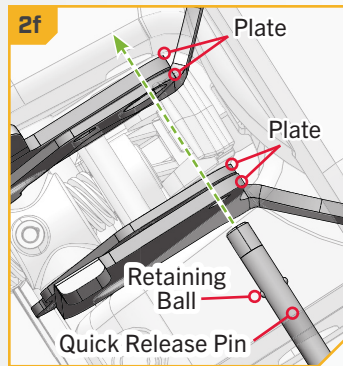
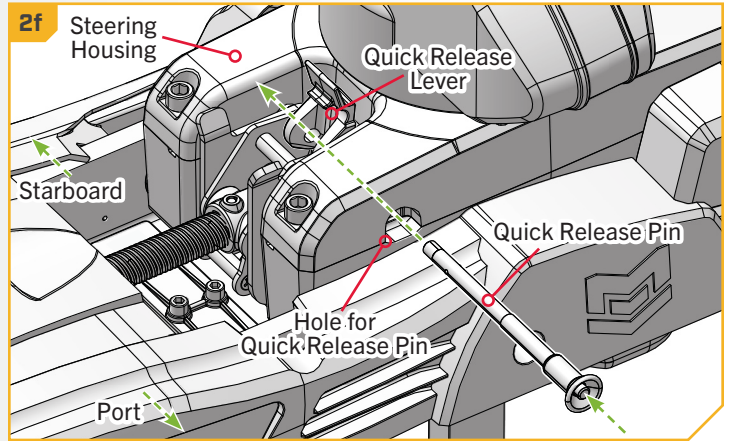

# SERVICE & MAINTENANCE

## PROP REPLACEMENT

### TOOLS AND RESOURCES REQUIRED >

- 9/16" Deep Well Socket

### INSTALLATION >

1

#### CAUTION

Disconnect the motor from all sources of power before beginning any prop work or maintenance.

- Hold the Prop and loosen the Prop Nut with a 9/16" Deep Well Socket.
- Remove the Prop Nut and Prop Washer.

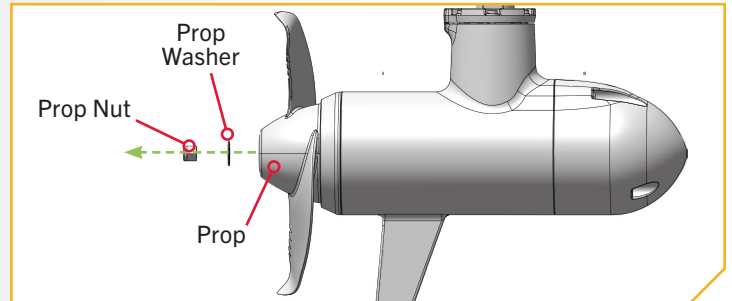

**NOTICE:** If the Drive Pin is sheared or broken, hold the Armature Shaft stationary with a Flat-Blade Screwdriver by pressing into the slot on the end of the shaft while loosening the Prop Nut.

2

- Turn the old Prop so it is horizontal and pull it straight off. If the Drive Pin falls out, push it back in.

#### CAUTION

If the Prop does not readily slide off, take care not to bend the Armature Shaft. Pull the Prop evenly off the Armature Shaft.

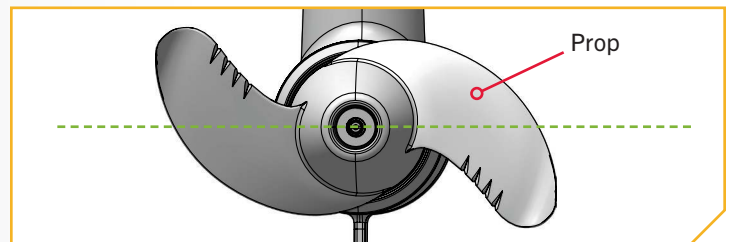

3

- Align the new Prop so it is horizontal and parallel with the Drive Pin. Slide the Prop onto the Armature Shaft and Drive Pin until it is seated against the lower unit.
- Reinstall the Prop Washer and Prop Nut onto the end of the Armature Shaft. While holding the Prop horizontal, tighten the Prop Nut with a 9/16" Deep Well Socket. Tighten the Prop Nut to 25-35 in-lbs.

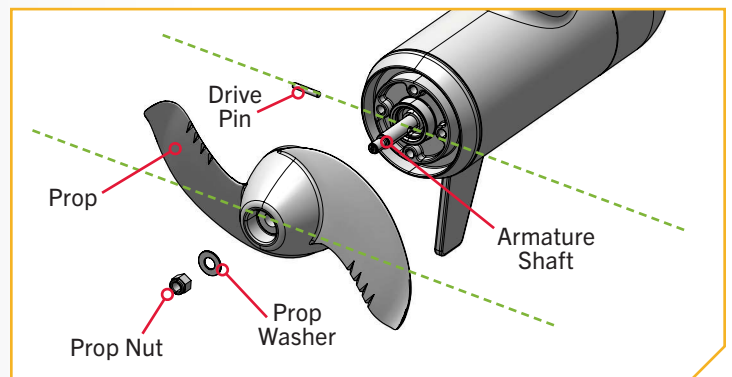

#### CAUTION

Do not over-tighten as this can damage the Prop.

# GENERAL MAINTENANCE



## GENERAL MAINTENANCE

- After use, the entire motor should be rinsed with freshwater.
- The composite shaft requires periodic cleaning and lubrication for proper retraction and deployment. A coating of an aqueous-based silicone spray will improve operation.
- The Prop must be inspected and cleaned of weeds and fishing line after every use. Fishing line and weeds can get behind the Prop, damage the seals and allow water to enter the motor.
- The Prop is designed to provide weed-free operation with very high efficiency. To maintain this top performance, the leading edge of the blades must be kept smooth. If they are rough or nicked from use, restore to smoothness by sanding with fine sandpaper.
- Verify that the Prop Nut is secure each time the motor is used.
- To prevent accidental damage during transportation or storage, disconnect the battery whenever the motor is off the water. For prolonged storage, lightly coat all metal parts with an aqueous-based silicone spray.
- When using lithium batteries, it is best to charge them right before using them. Storing lithium batteries in a fully charged state for long periods of time may cause damage to the batteries. Check with the battery manufacturer for specifics on the battery.
- For maximum battery life of all other batteries except lithium, recharge the battery(s) as soon as possible after use. For maximum motor performance, restore the battery to full charge prior to use. Check with the battery manufacturer for specifics on the battery.
- Keep battery terminals clean with fine sandpaper or emery cloth.
- Stow the motor after each use to allow water to drain from the Steering Housing. Water that sits in the steering housing when the motor is not in use may cause damage.
- When the motor is deployed, periodically check that the area between the Mount and Steering Housing is clean and free of debris. The Mount contains a Stow Pad that contacts the Steering Housing when stowed. If debris such as dirt, gravel, weeds, or fishing line enters this space, it may create an obstruction on the Stow Pad and prevent a secure stow. Periodically clean this space to ensure a secure stow.
- Periodically check the motor for loose hardware and damaged components.

## TROUBLESHOOTING

1. Motor fails to run or lacks power:
  - Check the state of the batteries and replace if necessary. Low battery voltage will cause an error.
  - Check battery connections for proper polarity.
  - Make sure the battery is charged.
  - Make sure terminals are clean and corrosion-free. Use fine sandpaper or emery cloth to clean terminals.
  - Check circuit protection devices.
  - Check battery water level. Add water if needed.
2. Motor loses power after a short running time:
  - Check battery charge. If low, restore to full charge, or replace.
3. You experience Prop vibration during normal operation:
  - Remove and rotate the Prop 180°. See removal instructions in the "Prop Replacement" section. Replace Prop if worn.
4. Experiencing interference with your fish finder:
  - You may, in some applications, experience interference in your fish finder display. We recommend that you use a separate deep cycle marine battery system for your trolling motor. If problems still persist, call our service department at 1-800-227-6433.



- 5. Motor contacts an object while trimming, causing an audible tone:
  - Reverse the direction of trimming to clear motor from obstruction.
- 6. Motor contacts an object while stowing, causing an audible tone:
  - Reverse the current cycle to clear the motor from the obstruction. Reverse the stow/deploy action with the wireless remote or One-Boat Network app.
- 7. Motor fails to trim:
  - Check main lift-belt tension per the "Motor Adjustments" section.
  - Conduct a Trim Reset procedure using the Indicator Panel at the base of the mount.
    - a. To conduct a Trim Reset, press the Power button on the Indicator Panel three times consecutively within a two-second period.
    - b. The blue System Status LED and orange Stowed LED will flash continuously while the Riptide Instinct QUEST goes through an automated sequence.
    - c. The motor will rotate into the Stow Orientation position.
    - d. The motor will trim up to the Mount and then trim down approximately six inches.
    - e. The flashing blue orange Stowed LED will turn off, and the flashing blue System Status LED will become solid blue.

WARNING

During the Trim Reset procedure, the motor will go into an automated sequence. Keep fingers clear of all hinges, pivot points and all moving parts. Ensure that the motor or parts of the motor do not contact the boat, trailer, persons, or any other obstruction.

- 8. Motor fails to stow or deploy:
  - Check for obstructions preventing the motor from deploying or stowing.
  - Check charge state of trolling motor batteries. If trolling motor battery icon on remote is flashing, battery charge is too low for operation.
  - If unable to stow by any other method, see the "Emergency Stow Procedures" section for details on manually stowing the motor.
- 9. Prop will not turn on:
  - Ensure batteries are sufficiently charged.
  - For safety reasons, there is a Prop Lockout Region (approx. 16" from bottom of Mount to center of Lower Unit). Ensure that the Lower Unit is not in this region.
- 10. Experiencing flashing red System Status  LED on the Indicator Panel:
  - The trolling motor is communicating that there is an error. Check the Wireless Remote Diagnostic menu for an error code, then refer to the Wireless Remote owner's manual for information on error codes and solutions. Correct the error and cycle power to the trolling motor. If the LED continues to flash red, please contact the Minn Kota service department.

**NOTICE:** For all other malfunctions, visit an Authorized Service Center. You can search for an Authorized Service Center in your area by visiting [minnkota.johnsonoutdoors.com](http://minnkota.johnsonoutdoors.com), or by calling our customer service number at 800-227-6433.

## FOR FURTHER TROUBLESHOOTING AND REPAIR



## FOR FURTHER TROUBLESHOOTING AND REPAIR

We offer several options to help you troubleshoot and/or repair your product. Please read through the options listed below.



### Buy Parts Online

You can buy parts online directly from our website at [minnkota.johnsonoutdoors.com](http://minnkota.johnsonoutdoors.com). From screws to sideplates, you can order replacement parts for your Minn Kota products.



### Frequently Asked Questions

Find answers to general inquiries, battery and rigging installation, and networking scenarios. We have FAQs available on our website at [minnkota.johnsonoutdoors.com](http://minnkota.johnsonoutdoors.com) to help answer all of your Minn Kota questions.



### Call Us (for U.S. and Canada)

Our consumer service representatives are available Monday – Friday between 7:00 a.m. – 4:30 p.m. CST at 800-227-6433. If you are calling to order parts, please have the 11-character serial number from your product, specific part numbers, and credit card information available. This will help expedite your call and allow us to provide you with the best consumer service possible. You can reference the parts list located in your manual to identify the specific part numbers.



### Contact Us

You can contact our consumer service department with questions regarding your Minn Kota products. To inquire, visit [minnkota.johnsonoutdoors.com](http://minnkota.johnsonoutdoors.com).



### Authorized Service Centers

Minn Kota has over 800 authorized service centers in the United States and Canada where you can purchase parts or get your products repaired. Please visit our website to locate a service center in your area.



Scan to visit  
Minn Kota  
service online.



# COMPLIANCE STATEMENTS

## ENVIRONMENTAL COMPLIANCE STATEMENT

It is the intention of JOME to be a responsible corporate citizen, operating in compliance with known and applicable environmental regulations, and a good neighbor in the communities where we make or sell our products.

### WEEE DIRECTIVE

EU Directive 2002/96/EC “Waste of Electrical and Electronic Equipment Directive (WEEE)” impacts most distributors, sellers, and manufacturers of consumer electronics in the European Union. The WEEE Directive requires the producer of consumer electronics to take responsibility for the management of waste from their products to achieve environmentally responsible disposal during the product life cycle.

WEEE compliance may not be required in your location for electrical & electronic equipment (EEE), nor may it be required for EEE designed and intended as fixed or temporary installation in transportation vehicles such as automobiles, aircraft, and boats. In some European Union member states, these vehicles are considered outside of the scope of the Directive, and EEE for those applications can be considered excluded from the WEEE Directive requirement.

This symbol (WEEE wheelee bin) on product indicates the product must not be disposed of with other household refuse. It must be disposed of and collected for recycling and recovery of waste EEE. Johnson Outdoors Inc. will mark all EEE products in accordance with the WEEE Directive. It is our goal to comply in the collection, treatment, recovery, and environmentally sound disposal of those products; however, these requirements do vary within European Union member states. For more information about where you should dispose of your waste equipment for recycling and recovery and/or your European Union member state requirements, please contact your dealer or distributor from which your product was purchased.

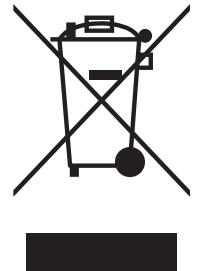

### DISPOSAL

Minn Kota motors are not subject to the disposal regulations EAG-VO (electric devices directive) that implements the WEEE directive. Nevertheless never dispose of your Minn Kota motor in a garbage bin but at the proper place of collection of your local town council.

Never dispose of battery in a garbage bin. Comply with the disposal directions of the manufacturer or his representative and dispose of them at the proper place of collection of your local town council.

## REGULATORY COMPLIANCE INFORMATION

### › Advanced GPS Navigation

For regulatory information on motors that come factory installed with Advanced GPS Navigation, please refer to the Advanced GPS Navigation Owner’s Manual online at [minnkota.johnsonoutdoors.com](http://minnkota.johnsonoutdoors.com).

# COMPLIANCE STATEMENTS



## FCC COMPLIANCE

This device complies with Part 15 of the FCC rules. **Operation is subject to the following two conditions:**

1. This device may not cause harmful interference.
2. This device must accept any interference that may be received, including interference that may cause undesired operation.

Changes or modifications not expressly approved by Johnson Outdoors Marine Electronics, Inc. could void the user's authority to operate this equipment.

**NOTICE:** This equipment has been tested and found to comply with the limits for a Class B digital device, pursuant to part 15 of the FCC Rules. These limits are designed to provide reasonable protection against harmful interference in a residential installation. This equipment generates, uses and can radiate radio frequency energy and, if not installed and used in accordance with the instructions, may cause harmful interference to radio communications. However, there is no guarantee that interference will not occur in a particular installation. **If this equipment does cause harmful interference to radio or television reception, which can be determined by turning the equipment off and on, the user is encouraged to try to correct the interference by one or more of the following measures:**

- Reorient or relocate the receiving antenna.
- Increase the separation between the equipment and receiver.
- Connect the equipment into an outlet on a circuit different from that to which the receiver is connected.
- Consult the dealer or an experienced radio/TV technician for help.

## INDUSTRY CANADA COMPLIANCE

This product meets the applicable Industry Canada technical specifications. Operation is subject to the following two conditions: (1) this device may not cause interference, and (2) this device must accept any interference, including interference that may cause undesired operation of the device.

## ENVIRONMENTAL RATINGS

Ambient operating temperature range: -10C to 50C

Ambient operating humidity range: 5% to 95%

Maximum operating altitude: 10,000 feet





# PARTS DIAGRAM & PARTS LIST

## RT INSTINCT QUEST - 90/115 THRUST - 24/36 VOLT - 60"/72"/87"/100" SHAFT

The parts diagram and parts list provides Minn Kota® WEEE compliance disassembly instructions. For more information about where you should dispose of your waste equipment for recycling and recovery and/or your European Union member state requirements, please contact your dealer or distributor from which your product was purchased. Tools required, but not limited to: flat head screwdriver, Phillips screwdriver, socket set, pliers, wire cutters.

### RT INSTINCT QUEST CONTROL HEAD >

#### > Control Head Parts Diagram

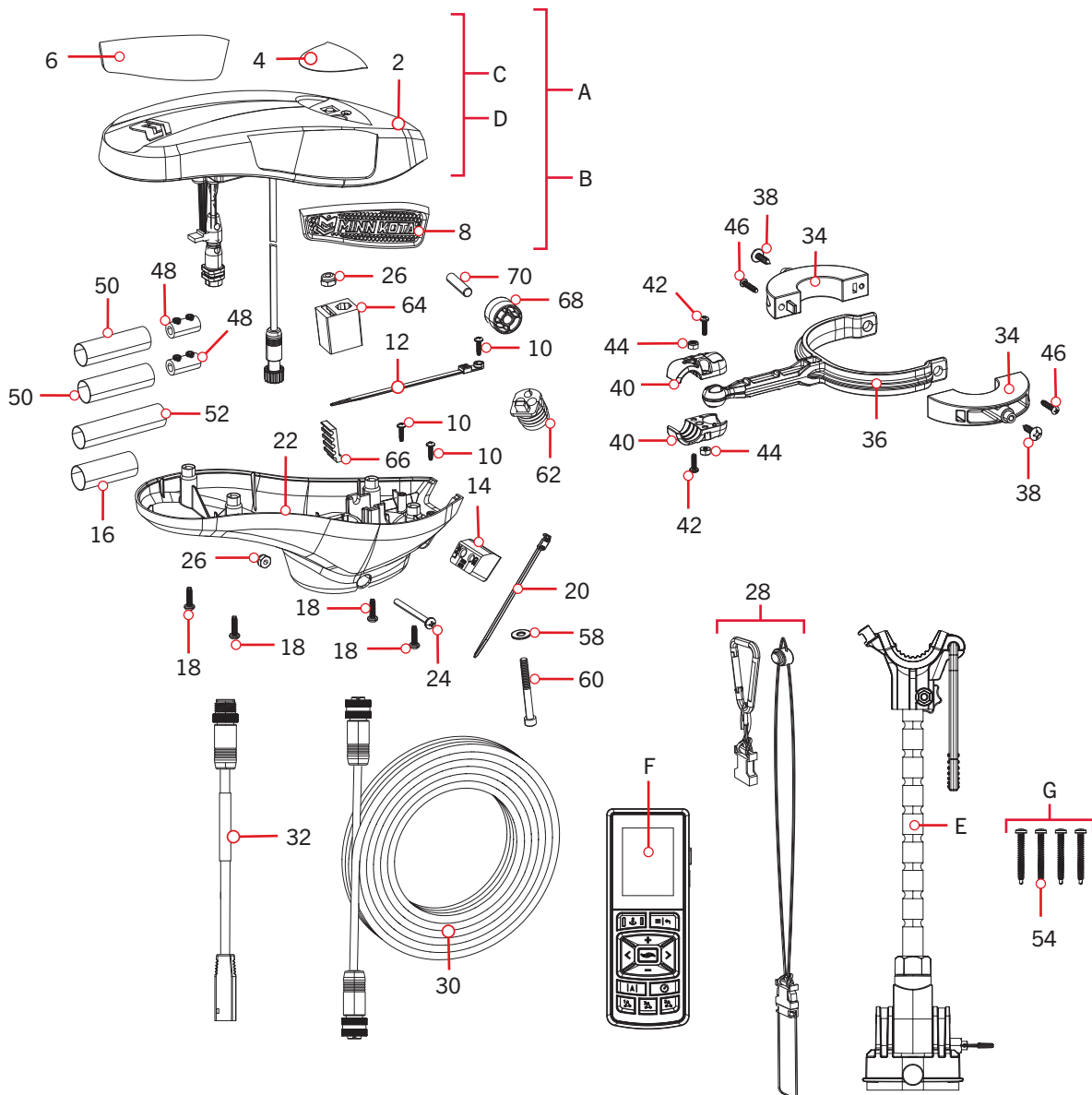

# PARTS DIAGRAM & PARTS LIST

## Control Head Parts List

Assembly	Part #	Description	Notes	Quantity
A	2994183	MTR KIT, 4.0 BL SW-BK WR	*RT INSTINCT QUEST* *SALTWATER BLACK*	1
B	2994194	MTR KIT, 4.0 BL SW WR	*RT INSTINCT QUEST* *SALTWATER WHITE*	1
C	2770248	CTRL BOX COVER QUEST SW WHT	*COVER & DECALS ONLY* *RT INSTINCT QUEST* *SALTWATER WHITE*	1
D	2770249	CTRL BOX COVER QUEST SW BLK	*COVER & DECALS ONLY* *RT INSTINCT QUEST* *SALTWATER BLACK*	1
E	2992371	STABILIZER, BWMT ES TM ASM	*72"* *87"* *100"*	1
F	411690-1	TROLLING MOTOR REMOTE		1
G	2994955	BAG, ASM MKA-60 STABILIZER	*72"* *87"* *100"*	1
Item	Part #	Description	Notes	Quantity
2	2200221	CONTROL BOX COVER, WHITE	*SALTWATER WHITE*	1
	2200220	CONTROL BOX COVER, BLACK	*SALTWATER BLACK*	1
4	2395561	DECAL,PUSH BTN, INST, WHT	*SALTWATER WHITE*	1
	2395595	DECAL, PUSH BTN, INSTINCT	*SALTWATER BLACK*	1
6	2205543	DECAL, CTRL BOX MK RIGHT SW		1
8	2205548	DECAL, CTRL BOX MK LEFT SW		1
10	2203441	SCREW-#6 X 1/2" THRD FORM,SSTL		3
12	2206302	TIE WRAP,SCREW MOUNT 6.3"		1
14	2206710	PLUG, RUBBER, DI/SI		1
16	2205412	SHRINK TUBE-.75 ID X 2"		1
18	2372100	SCREW-#8-18 X 5/8 THD* (SS)		4
20	2206301	TIE WRAP, LOW PROFILE 8"		1
22	2202521	CONTROL BOX BASE, ULTERRA SW	*SALTWATER WHITE*	1
	2202520	CONTROL BOX BASE, ULT,UTX, FW	*SALTWATER BLACK*	1
24	2263406	SCREW-#10-24 X 2" S/S PPH		1
26	2333101	NUT-HEX #10-24 UNC-2B NYL SS		2
28	2390802	LANYARD w/CARABINER IP RMT U2		1
30	490637-4	CABLE, ETH, M12-M12, BRAID,30'		1
32	490380-1	CABLE, ETHERNET PIGTAIL-700 HD		1
34	2201530	COLLAR HALF, COIL CORD	*72"* *87"* *100"*	2
36	2201531	COLLAR ARM, COIL CORD	*72"* *87"* *100"*	1
38	2203424	SCREW-#10-12 x.75 PTH SS	*72"* *87"* *100"*	2
40	2200860	CLAMP-BALL,COIL CORD SLDR	*72"* *87"* *100"*	2
42	830-065	SCREW-#6-32 X 1/2" TORX PH SS	*72"* *87"* *100"*	2
44	2323110	NUT-HEX, 6-32 NYLOK SS	*72"* *87"* *100"*	2
46	2203460	SCREW-#8 X 0.75 PPH HI-LO SS	*72"* *87"* *100"*	2
48	2375444	SPLICER, 6-10 AWG, TIN PLTD		2
50	2205413	SHRINK TUBE-3/4 X 2.25"		2
52	2205410	SHRINK TUBE-.472 ID X 4"		1

▲ Not shown on Parts Diagram.

\* This part is included in an assembly and cannot be ordered individually.

# PARTS DIAGRAM & PARTS LIST



Item	Part #	Description	Notes	Quantity
54	2383475	SCREW - #8-18 X 1 1/2 SELF DR SS	*72"* *87"* *100"*	4
58	2201721	WASHER - #10 SAE.I, SS		1
60	2203411	SCREW-#10-24,SHCS,SS, RIE 4606		1
62	2206721	PLUG-WIRE, ROUND	*87"* *100"*	1
64	2202800	BLOCK-BELT		1
66	2200800	BELT-RACK, LOWER		1
68	2202335	PULLEY, BELY TOP		1
70	2202635	PIN-DOWEL, 1/4" OD SS		1
▲	2207127	MANUAL, INSTINCT		1
▲	2207128	MANUAL, INSTL GD, INSTINCT		1
▲	2297165	MANUAL-DISCLAIMER,DWNLOAD INFO		1
▲	2294950	INSTRUCTIONS,OBV & REMOTE PAIR		1
▲	2397115	GUIDE-QUICK REFERENCE iP 4.0		1
▲	2397110	MANUAL, iPILOT 4.0		1
▲	2207130	BRUSHLESS QS SETUP GUIDE		1
▲	2207126	QK REF GUIDE,ULT Q/INST Q		1
▲	2395540	DECAL, COMPLIANCE, KIT 1.6, 3.0		1
▲	2377179	INSTR. SHEET, MKA-60 STABILIZER	*72"* *87"* *100"*	1
▲	2206819	LABEL-CARTON "CAUTION HEAVY"		1

▲ Not shown on Parts Diagram.

✘ This part is included in an assembly and cannot be ordered individually.



# PARTS DIAGRAM & PARTS LIST

## RT INSTINCT QUEST MOTOR

### 24/36 Volt 90/115 Thrust Motor Parts Diagram

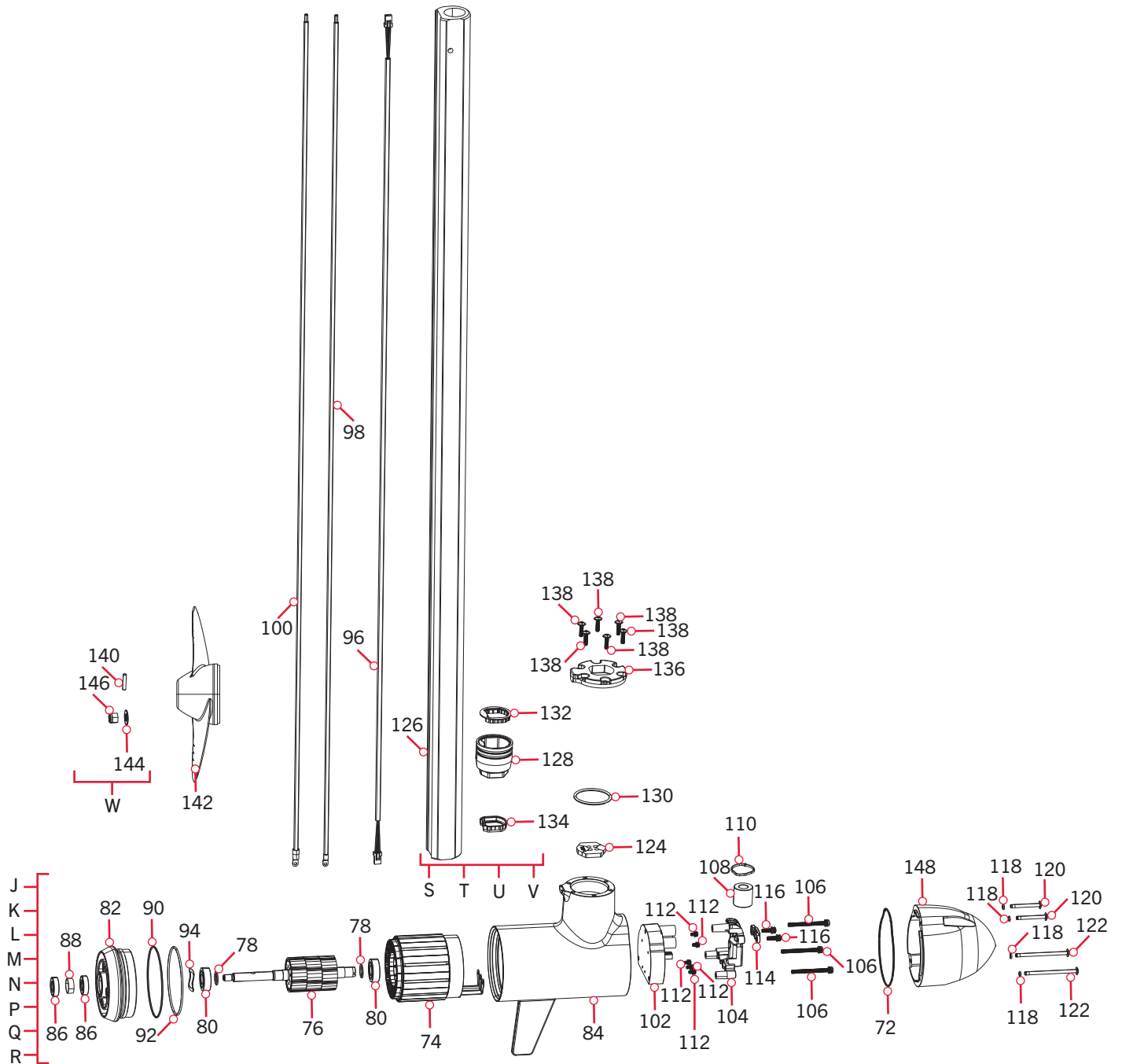

# PARTS DIAGRAM & PARTS LIST

## ▶ 24/36 Volt 90/115lb Thrust Motor Parts List

Assembly	Part #	Description	Notes	Quantity
J	2441050	MTR ASY 90/115# NS SW WHT 60"	*60"* *SALTWATER WHITE*	1
K	2441051	MTR ASY 90/115# NS SW WHT 72"	*72"* *SALTWATER WHITE*	1
L	2441052	MTR ASY 90/115# NS SW WHT 87"	*87"* *SALTWATER WHITE*	1
M	2441053	MTR ASY 90/115# NS SW WHT 100"	*100"* *SALTWATER WHITE*	1
N	2441055	MTR ASY 90/115# NS SW BLK 60"	*60"* *SALTWATER BLACK*	1
P	2441056	MTR ASY 90/115# NS SW BLK 72"	*72"* *SALTWATER BLACK*	1
Q	2441057	MTR ASY 90/115# NS SW BLK 87"	*87"* *SALTWATER BLACK*	1
R	2441058	MTR ASY 90/115# NS SW BLK 100"	*100"* *SALTWATER BLACK*	1
S	2991065	SHAFT ASM 60" U2,T3 *60"*	*SHAFT* *60"*	1
T	2991051	SHAFT ASM 72"INST,RT/T3 *72"*	*SHAFT* *72"*	1
U	2991052	SHAFT ASM 87"INST,RT/T3 *87"*	*SHAFT* *87"*	1
V	2991053	SHAFT ASM 100"INS,RT/T3 *100"*	*SHAFT* *100"*	1
W	2992604	BAG ASSM, PROP HARDWARE		1
Item	Part #	Description	Notes	Quantity
72	880-032	SEAL-FRONT, BL MOTORS		1
74	✘	STATOR ASSEMBLY		1
76	✘	ROTOR ASSEMBLY		1
78	✘	WASHER BEARING		2
80	✘	BALL BEARING		2
82	✘	REAR ENDBELL, SW WHT PAINT	*SALTWATER WHITE*	1
	✘	REAR ENDBELL, SW PAINT BLACK	*SALTWATER BLACK*	1
84	✘	CENTER HSG, SW WHT PAINT	*SALTWATER WHITE*	1
	✘	CENTER HSG, SW BLACK PAINT	*SALTWATER BLACK*	1
86	✘	SEAL		2
88	✘	PAPER TUBE - SEAL BORE		1
90	✘	O-RING		1
92	✘	O-RING		1
94	✘	WASHER-WAVE		1
96	195-032	CABLE-COM 22GA TWST PAIR 76.25	*60"*	1
	195-033	CABLE-COM 22GA TWST PAIR 87.63	*72"*	1
	195-034	CABLE-COM 22G TWST PAIR 102.63	*87"*	1
	195-035	CABLE-COM 22G TWST PAIR 111.38	*100"*	1
98	640-472	LEADWIRE RED 8 AWG 78.75"	*60"*	1
	640-483	LEADWIRE RED 6 AWG 90.13"	*72"*	1
	640-484	LEADWIRE RED 6 AWG 105.13"	*87"*	1
	640-485	LEADWIRE RED 6 AWG 118.13"	*100"*	1

▲ Not shown on Parts Diagram.

✘ This part is included in an assembly and cannot be ordered individually.

# PARTS DIAGRAM & PARTS LIST



Item	Part #	Description	Notes	Quantity
100	640-422	LEADWIRE BLK 8 AWG 78.75"	*60"	1
	640-433	LEADWIRE BLK 6 AWG 90.13"	*72"	1
	640-434	LEADWIRE BLK 6 AWG 105.13"	*87"	1
	640-435	LEADWIRE BLK 6 AWG 118.13"	*100"	1
102	2994130	INVERTER ASM, 24/36V, BL		1
104	979-031	STRAIN RELIEF,BTM MACH WIRETAB		1
106	830-118	SCREW-DBL SEM M5X.8MMX60MM		3
108	2307318	FERRITE BEAD, BL		1
110	9953310	TIE WRAP-8"		1
112	830-120	SCREW-M4X .7X8 PPH ZPS		5
114	979-022	STRAIN RELIEF, TOP CAST		1
116	830-121	SCREW-M5 X .8X18 PPH ZPS		2
118	701-010	O-RING, SCREW		4
120	830-115	SCREW-FRONT, TOP, COATED, BL MTR		2
122	830-116	SCREW-FRONT, BTM COATED, BL MTR		2
124	880-042	SEAL-WIRE, BL MTR, PLAIN END		1
126	✘	TUBE-1CM, BLK 60", 1.5 X .875	*60"	1
	✘	TUBE-5CM, BLK 72", 1.5 X .75	*72"	1
	✘	TUBE-5CM, BLK 87", 1.5 X .75	*87"	1
	✘	TUBE-5CM, BLK 100", 1.5 X .75	*100"	1
128	✘	PLUG, COMP SHAFT, PAINTED		1
130	2294630	O-RING, 226, 70 SHORE A		1
132	✘	SEAL-TOP SHAFT, BRUSHLESS, CLR		1
134	✘	SEAL-LWR SHAFT, BRUSHLESS, CLR		1
136	2206452	PLATE, CLAMP, PAINTED, BELT		1
138	830-013	SCREW-M5 X .8 FSHCS SS CTD		6
140	2262659	PIN-DRIVE 1" X 3/16" SS 17-4		1
142	2321170	PROP, POWER REAMED		1
144	2091701	WASHER-PROP (LARGE) MAX101		1
146	2093101	NUT-PROP,NYLOC,LG,MX101 3/8 SS		1
▲	2005764	DECAL, SERIAL NO, BL LWR UNT		1
148	421-168	FRONT ENDBELL, PLAIN, SW WHT PNT	*SALTWATER WHITE*	1
	421-169	FRONT ENDBELL, PLAIN, SW BLACK	*SALTWATER BLACK*	1

▲ Not shown on Parts Diagram.

✘ This part is included in an assembly and cannot be ordered individually.



# PARTS DIAGRAM & PARTS LIST

## RT INSTINCT QUEST STEERING HOUSING

### Steering Housing Parts Diagram

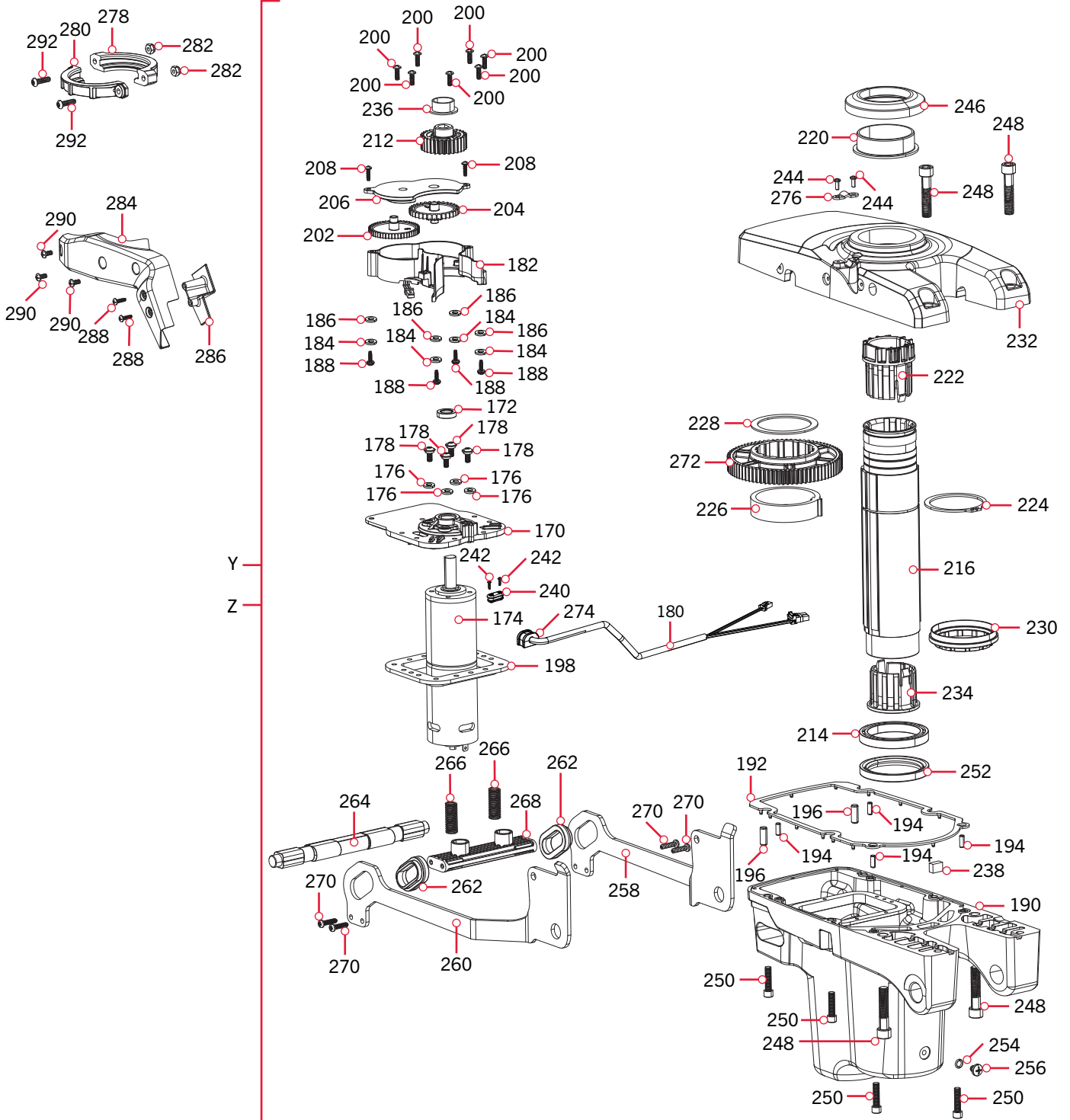

# PARTS DIAGRAM & PARTS LIST

## › Steering Housing Parts List

Assembly	Part #	Description	Notes	Quantity
Y	2996531	ASM, STEERING, SW, WHT	*SALTWATER WHITE*	1
Z	2996532	ASM, STEERING, SW BLK	*SALTWATER BLACK*	1
Item	Part #	Description	Notes	Quantity
170	2206401	PLATE, MOTOR MNT, STEERING		1
172	2204640	SEAL, ID 12MM, OD 20MM, T 5MM		1
174	2207012	MOTOR, 24 VDC, 1:130 GEARBOX		1
176	2204617	O-RING, 3/16 ID X 3/8 OD		4
178	2203414	SCREW-M5X.8X12, FLANGED BTN HD		4
180	2200602	STEERING CORD ASM		1
182	2204040	SENSOR, STEERING, ROTATIONAL, I/T		1
184	2374628	SEALING WASHER, RUBBER		4
186	2071714	WASHER-FLAT #6 S/S		4
188	2203441	SCREW-#6 X 1/2" THRD FORM, SSTL		4
190	2326568	HSG-BTM, STRING, SW, WHT	*SALTWATER WHITE*	1
	2206575	HSG-BTM, STEERING, SW, BLK	*SALTWATER BLACK*	1
192	2204621	SEAL, STEERING HOUSING SPLIT		1
194	2202619	PIN-DOWEL, 3/16 X 1/2, SS		4
196	2382682	PIN-DOWEL, 1/4" X 5/8" SS		2
198	2206920	GASKET, MOTOR HOUSING, STEERING		1
200	2332101	SCREW-#8-32 X 1/2 (SS)		7
202	2992225	GEAR-STEER SENSOR, 51T, w/MAGNET		1
204	2202214	GEAR-TRIM, 14T		1
206	2206572	COVER, STEER SENSOR GEARS		1
208	2203441	SCREW-#6 X 1/2" THRD FORM, SSTL		2
210 ▲	9950433	TIE WRAP-4" BLACK(#21041)		1
212	2202212	GEAR, 30 TOOTH, PINION, STEERING		1
214	2207302	BRG, 55 X 72 X 9MM, SSTL		1
216	2202000	OUTPUT TUBE, ANDIZED		1
218 ▲	2204606	O-RING, -139, NOM ID 2.25,		1
220	2207320	BUSHING, 55MM, JFM-5560-50		1
222	2207321	BUSHING, OUTPUT TUBE, TOP, INSTNC		1
224	2293001	RETAINING RING, 2 3/8"		1
226	2207911	HUB, STEERING STOP, ANODIZED		1
228	2201715	WASHER-THRUST, OUTPUT TUBE		1
230	2205910	GREASE CAP BEARING		1
232	2206563	HSG-TOP, STEERING, SW, WHT	*SALTWATER WHITE*	1
	2206559	HSG-TOP, STEERING, SW BLK	*SALTWATER BLACK*	1

▲ Not shown on Parts Diagram.

\* This part is included in an assembly and cannot be ordered individually.



# PARTS DIAGRAM & PARTS LIST



Item	Part #	Description	Quantity
234	2207345	BUSHING, OUTPUT TUBE, LOWER	1
236	2207340	BUSHING, JFM-2023-11	1
238	2208640	VENT FILTER, STEERING HOUSING	1
240	2201941	MNT, SENSOR, LATCH QRP	1
242	2373440	SCREW-#4-24 X 1/4 PHCR SS TY B	2
244	2293403	SCREW-#6-32 X .625 PPH SS	1
246	2204642	SEAL, UMBRELLA	1
248	2203453	SCREW-3/8-16 X 1.75 SHCS SS NYSHD	4
250	2323436	SCREW-1/4-20 X 1" SHC, SS NYSHIELD	4
252	2294601	SEAL, OUTPUT	1
254	2204618	O-RING, SAE-010, BUNA-N	1
256	2203429	SCREW-1/4-20 X .313 PLASTIC	1
258	2201925	BRACKET, LATCH RELEASE, RIGHT	1
260	2201926	BRACKET, LATCH RELEASE, LEFT	1
262	2207306	BUSHING, LATCH PIN	2
264	2202624	PIN-LATCH, OVERMOLDED	1
266	2202705	SPRING, COMPRESS, 1.25 L, 0.63 CMP	2
268	2207210	HANDLE, LATCH BRACKET	1
270	3393481	SCREW-#10X.75" PPH HI-LO (SUB)	4
272	2202210	GEAR, 78 TOOTH, OUTPUT TUBE	1
274	2202920	GROMMET, QRP SENSER HARNESS	1
276	2207410	HARNESS, QRP SNSR, HALL EFF	1
278	2200845	CLAMP, TRIM-STEER, L, MACH	1
280	2200846	CLAMP, TRIM-STEER, R, MACH	1
282	2333101	NUT-HEX #10-24 UNC-2B NYL SS	2
284	2206412	COVER, CABLE, STEER HOUSING BLACK	*SALTWATER BLACK*
	2206416	COVER, CABLE, STEER HSG, WHT	*SALTWATER WHITE*
286	2206413	BACKING, CABLE COVER	1
288	2203441	SCREW-#6 X 1/2" THRD FORM, SSTL	2
290	2332100	SCREW-#8-32 X 3/8 MACHINE	3
292	2383469	SCREW-#10-24 X 3/4, SS, BHCS	2

▲ Not shown on Parts Diagram.

✘ This part is included in an assembly and cannot be ordered individually.



# PARTS DIAGRAM & PARTS LIST

## RT INSTINCT QUEST TRIM HOUSING

### Trim Housing Parts Diagram

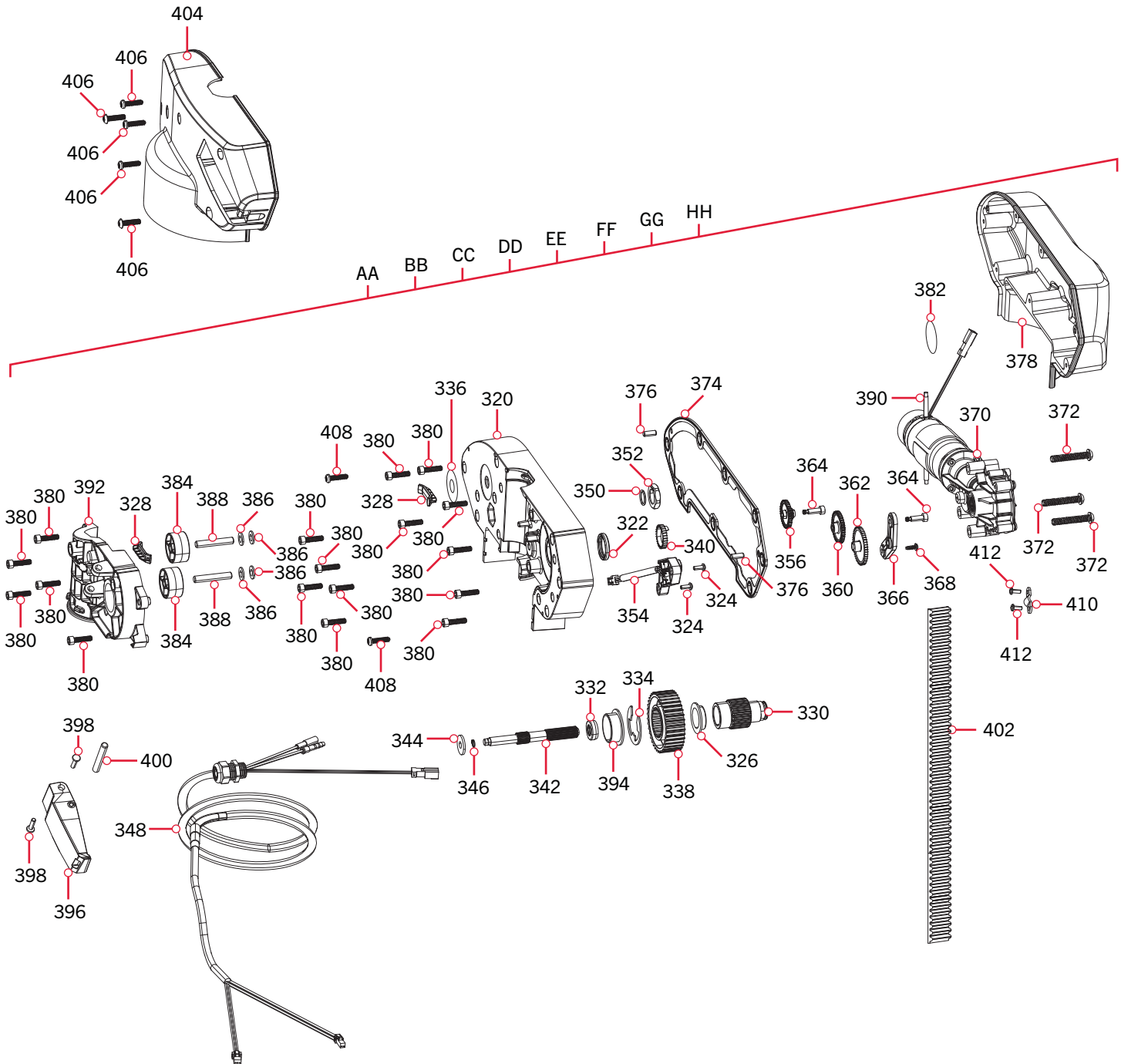

# PARTS DIAGRAM & PARTS LIST

## Trim Housing Parts List

Assembly	Part #	Description	Notes	Quantity
AA	2997853	ASM, TRIM MOD,SW, WHT,60"	*60"* *SALTWATER WHITE*	1
BB	2997854	ASM, TRIM MOD,SW, WHT,72"	*72"* *SALTWATER WHITE*	1
CC	2997855	ASM, TRIM MOD,SW, WHT,87"	*87"* *SALTWATER WHITE*	1
DD	2997859	ASM, TRIM MOD,SW, WHT,100"	*100"* *SALTWATER WHITE*	1
EE	2997856	ASM, TRIM MOD,SW, BLK,60"	*60"* *SALTWATER BLACK*	1
FF	2997857	ASM, TRIM MOD,SW, BLK,72"	*72"* *SALTWATER BLACK*	1
GG	2997858	ASM, TRIM MOD,SW, BLK,87"	*87"* *SALTWATER BLACK*	1
HH	2997860	ASM, TRIM MOD,SW, BLK,100"	*100"* *SALTWATER BLACK*	1
Item	Part #	Description	Notes	Quantity
320	2206584	HOUSING-MID,TRIM, SW, WHT	*SALTWATER WHITE*	1
	2206579	HOUSING-MID, TRIM, SW BLK	*SALTWATER BLACK*	1
322	2204632	SEAL,LIP,3/4 ID X 1 OD X 1/8 L		1
324	2073414	SCREW-#6-32 X .375 PPH SS(N/A)		2
326	2207335	BUSHING, FLANGED, 3/4 SHAFT		1
328	2205126	BUMPER, WEAR, TRIM		2
330	2207916	HUB, TRIM PULLEY, ANODIZE		1
332	2204631	SEAL,LIP,5/16 ID X 3/4 ODX1/4L		1
334	2203030	RING, RETAIN, TRIM COUNT		1
336	2201727	WASHER, SLIP, TRIM		1
338	2202355	PULLEY, 38T, 1062-20 GROB IN		1
340	2202235	GEAR, PINION, TRIM COUNT		1
342	2202312	SPLINE SHAFT, PULLEY,TRIM		1
344	2201726	WASHER,ID .281, OD .75, T .075		1
346	2203032	RETAINING RING, 1/4"		1
348	2991263	TRIM CORD ASM		1
350	2204619	O-RING, HEYCO, 12X2MM, BUNA-N		1
352	2203102	NUT, PG 9, STRAIN RELIEF		1
354	2204041	SENSOR, TRIM, ROTATIONAL, I		1
356	2202222	GEAR, 12T/35T		1
360	2202223	GEAR, 13T/40T		1
362	2992224	GEAR-TRIM SENSOR,48T, w/MAGNET		1
364	2203500	BOLT-SHOULDER, #8-32 THD, SSTL		2
366	2206442	CAP, TRIM MAGNET SENSOR GEAR		1
368	2372103	SCREW-#6 X .375 PLASTITE SS		1
370	2997014	MOTOR, TRIM, 42MM, RIGHT ANGLE		1
372	2293417	SCREW-1/4-20 X 1.50" BHCS SS		3
374	2206926	GASKET, INSTINCT, TRIM		1

▲ Not shown on Parts Diagram.

\* This part is included in an assembly and cannot be ordered individually.

# PARTS DIAGRAM & PARTS LIST



Item	Part #	Description	Notes	Quantity
376	2202619	PIN-DOWEL, 3/16 X 1/2, SS		2
378	2206589	HSG-MTR CVR, TRIM,SW, WHT	*SALTWATER WHITE*	1
	2206590	HSG-MTR CVR, TRIM, SW BLK	*SALTWATER BLACK*	1
380	2203423	SCREW-#10-24 x .75, SHCS, SS		17
382	2205130	VENT PATCH, YLW/BLK		1
384	2202352	PULLEY-IDLER, TRIM, REAMED		2
386	2201736	WASHER, PLASTIC, .265 ID, .5 OD		4
388	2202610	PIN, BELT PULLEY		2
390	2204635	SEAL, 1/16 O-RING CORD, SILICONE		1
392	2201521	COLLAR, OUTPUT TUBE, MACH		1
394	2207336	BUSHING, FLANGED, 1.0 SHAFT		1
396	2200115	LEVER, TRIM RELEASE, MACH.		1
398	2202670	PIN, KNURL, HEAD, 4MM X 8MM		2
400	2202639	PIN-DOWEL, 1/4 X 1.75 LG		1
402	2200818	BELT-LIFT 5MM HTD		1
404	2206523	TRIM HOUSING, OD COVER SW		1
	2206524	TRIM HOUSING, OD COVER FW		1
406	2383469	SCREW-#10-24 X 3/4, SS, BHCS		5
408	3393481	SCREW-#10X.75" PPH HI-LO (SUB)		2
410	2200850	CLAMP, TRIM CABLE		1
412	2073414	SCREW-#6-32 X .375 PPH SS(N/A)		2

▲ Not shown on Parts Diagram.

✘ This part is included in an assembly and cannot be ordered individually.



# PARTS DIAGRAM & PARTS LIST

## RT INSTINCT QUEST MOUNT

### Mount Parts Diagram

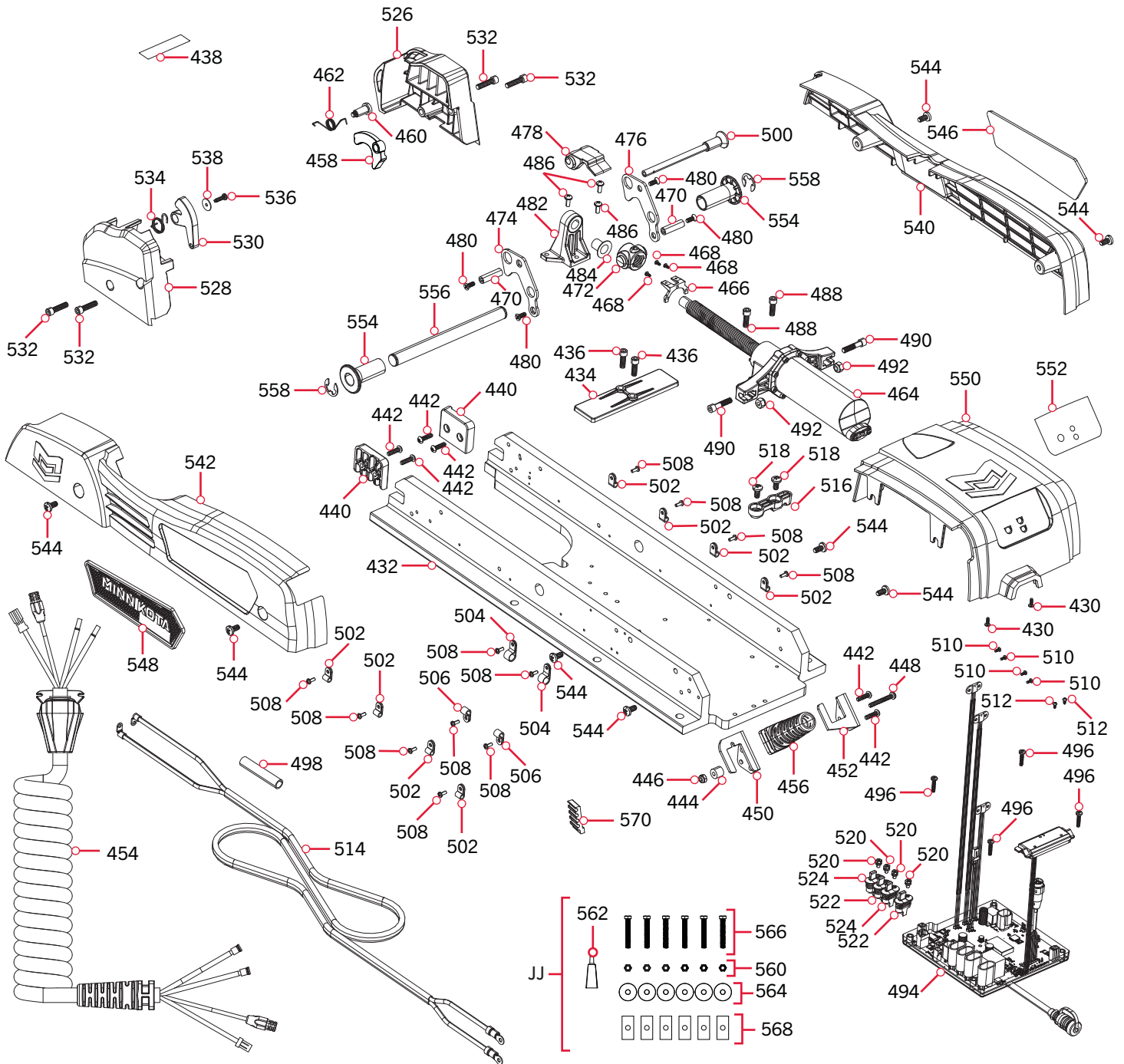

# PARTS DIAGRAM & PARTS LIST

## Mount Parts List

Assembly	Part #	Description	Notes	Quantity
JJ	2994948	BAG, ASM, INSTINCT, T3 BL HDW		1
Item	Part #	Description	Notes	Quantity
430	2372103	SCREW-#6 X .375 PLASTITE SS		2
432	2201907	BASE, MACHINED, SW		1
434	2205106	PAD, DEAD STOP, STOW		1
436	2373434	SCREW-1/4-20 X 3/4 SS PPMS		2
438	2205518	DECAL-INSTRUCTIONS, TRIM BYPASS		1
440	2323211	STOP-DEAD, DEPLOY		2
442	2383469	SCREW-#10-24 X 3/4, SS, BHCS		6
444	2202907	STANDOFF, .5 ODX.19 IDX.44 L, PL		1
446	2333101	NUT-HEX #10-24 UNC-2B NYL SS		1
448	2203426	SCREW-#10-24 x 1.5 SS BHCS		1
450	2200828	CLIP-CORD BACKUP MT PLATE		1
452	2200829	CLIP-CORD MT BRACKET		1
454	2991245	COIL CORD ASM 45" - 60"	*60"	1
	2991246	COIL CORD ASM 72"	*72"	1
	2991247	COIL CORD ASM 87"	*87"	1
	2991248	COIL CORD ASM 100"	*100"	1
456	*	STRAIN RELIEF, MOUNT INSTINCT		1
458	2997925	CAM, LATCH, SENSOR w/MAGNET		1
460	2203510	BOLT-SHOULDER, POLYMER, CAM SNSR		1
462	2042711	SPRING-TORSION, SS		1
464	2997814	ASSEMBLY, TILT MOTOR, ULTERRA		1
466	2202326	SUPPORT, TILT SHAFT MID		1
468	2373440	SCREW-#4-24 X 1/4 PHCR SS TY B		3
470	2202930	SPACER, TILT LINKS		2
472	2993300	KNUCKLE, TILT 3/4-8 w/MAG		1
474	2204220	LINK-TILT, LEFT		1
476	2204225	LINK-TILT, RIGHT		1
478	2207331	BUSHING, E-PIN ECCENTRIC		1
480	2203410	SCREW-#10-32 X .5"		4
482	2202324	SUPPORT, TLT SHFT END, REAM		1
484	2207341	BUSHING, RFI-0810-10		1
486	2373481	SCREW-#10-32 X 1/2" SEMS PPH SS		3
488	2263452	SCREW-1/4-20 X 3/4 SHCS S/S		2
490	2073410	SCREW-1/4-20 X 1.125 SHCS SS		2

▲ Not shown on Parts Diagram.

\* This part is included in an assembly and cannot be ordered individually.

# PARTS DIAGRAM & PARTS LIST



Item	Part #	Description	Notes	Quantity
492	2203120	NUT-1/4-20 NYLOK, RIE COATED		2
494	2204030	CTRL BOARD ASM, MAIN ULTERRA 2		1
496	2373487	SCREW-#8-32 X 3/4" PPH MACH SS		4
498	2205412	SHRINK TUBE.75 ID x 2"		1
500	2202623	PIN,QCK REL. 5/16 x 3 1/2		1
502	2052510	CABLE CLAMP, 3/16", NYLON		8
504	2040721	CLAMP-CABLE 3/8"		2
506	2052511	CABLE CLAMP,1/4" VANTAGE		3
508	2073414	SCREW-#6-32 X .375 PPH SS(N/A)		12
510	2203440	SCREW-#4-40 X 1/4 PPH SS		4
512	2373440	SCREW-#4-24 X 1/4 PHCR SS TY B		2
514	2200625	LEADWIRE ASM,8AWG,ULT 2 (DPLX)		1
516	2202919	STRAIN RELIEF, POWER		1
518	2323405	SCREW-1/4-20 X 1/2" MCH SS		2
520	830-123	SCREW-M4 X .7X8MM HEX DBL SEMS		4
522	2294610	SEAL, PCBA TERMINAL GRAY .215		2
524	2294611	SEAL, PCBA TERMINAL BLACK .270		2
526	2203930	RAMP-MOTOR, RIGHT		1
528	2203935	RAMP-MOTOR, LEFT		1
530	2997907	RAMP/ACTUATOR ASM w/MAGNET		1
532	2263453	SCREW-1/4-20 X 1" SHCS S/S		4
534	2202708	SPRING-TORSION,RGT HND WIND,SS		1
536	2372100	SCREW-#8-18 X 5/8 THD* (SS		1
538	2201723	WASHER-#6, .625 OD, SS		1
540	2203921	SIDEPLATE, RIGHT, WHITE	*SALTWATER WHITE*	1
	2203920	SIDEPLATE, RIGHT, BLACK	*SALTWATER BLACK*	1
542	2203926	SIDEPLATE, LEFT, WHITE	*SALTWATER WHITE*	1
	2203925	SIDEPLATE, LEFT, BLACK	*SALTWATER BLACK*	1
544	2323405	SCREW-1/4-20 X 1/2" MCH SS		8
546	2205558	DECAL, SIDEPLATE RIGHT SW		1
548	2205559	DECAL, SIDEPLATE LEFT SW		1
550	2206516	HOUSING-CONTROL, WHITE	*SALTWATER WHITE*	1
	232344	HOUSING-CONTROL, BLACK	*SALTWATER BLACK*	1
552	2205611	DECAL-PWR SWITCH, SW, WHT	*SALTWATER WHITE*	1
	2205612	DECAL-PWR SWITCH, SW, BLK	*SALTWATER BLACK*	1
554	2207311	BUSHING, STEER HOUSING PIVOT		2
556	2202650	SHAFT, SUPPORT, TILT		1
558	2373013	E-RING, EXTERNAL SS .625, HNDL		2

▲ Not shown on Parts Diagram.

✳ This part is included in an assembly and cannot be ordered individually.



# PARTS DIAGRAM & PARTS LIST



Item	Part #	Description	Notes	Quantity
560	2383122	NUT 3/8-16 NYLON INST LOCKNUT		6
562	2378608	ANTI-SEIZE TUBE 4CC, TALON		1
564	2321710	WASHER, RUBBER MOUNT		6
566	2323440	SCREW-3/8-16X 2 1/2 HHCS SS		6
568	2371796	BACKUP BAR 3/16 X 1 X 2		6
570	2206576	RACK, BELT, TAPER, ANODIZED		1

▲ Not shown on Parts Diagram.

✘ This part is included in an assembly and cannot be ordered individually.





# NOTES



Lined area for taking notes, consisting of multiple horizontal lines.

# RECOMMENDED ACCESSORIES

## › ON-BOARD & PORTABLE BATTERY CHARGERS

Stop buying new batteries and start taking care of the ones you've got. Many chargers can actually damage your battery over time – creating shorter run times and shorter overall life. Digitally controlled Minn Kota chargers are designed to provide the fastest charge that protect and extend battery life.



MK212PCL



MK210D



MK110PD

## › TALON SHALLOW WATER ANCHOR

Talon is the only shallow water anchor with up to 15' of anchoring depth, multiple anchoring modes, and control from the bow, transom, console, remote or mobile device.



### BUILT-IN WORK LIGHT

Lets you tie lines and work from the transom any time of day — or night. Includes both white and blue LED lights with three brightness settings.



### BLUETOOTH® CONNECTIVITY

Lets you control Talon from your mobile device and easily update it. Also opens up communication to other control options.



### UP TO 15' DEEP

Control more water and catch more fish with the first 15' shallow water anchor.



### MORE CONTROL OPTIONS

- Control Panel
- Wireless Remote
- Mobile App
- Wireless Foot Switch
- Humminbird® Connectivity
- Advanced GPS Navigation System Remote



## › MINN KOTA ACCESSORIES

We offer a wide variety of trolling motor accessories, including:

- 60-Amp Circuit Breaker
- Mounting Brackets
- Stabilizer Kits
- Boat Deck Reinforcement Kit
- Battery Connectors
- Battery Boxes
- Quick Connect Plugs



minnkota.johnsonoutdoors.com    

Part #2207127

Minn Kota Consumer & Technical Service  
Johnson Outdoors Marine Electronics, Inc.  
PO Box 8129  
Mankato, MN 56001

121 Power Drive  
Mankato, MN 56001  
Phone (800) 227-6433  
Fax (800) 527-4464



©2023 Johnson Outdoors Marine Electronics, Inc.  
All rights reserved.

ECN 44313

Rev A

10/23