

# PARTS DIAGRAM & PARTS LIST

## MAXXUM 70 - 70 LBS THRUST - 24 VOLT - 42" SHAFT

The parts diagram and parts list provides Minn Kota® WEEE compliance disassembly instructions. For more information about where you should dispose of your waste equipment for recycling and recovery and/or your European Union member state requirements, please contact your dealer or distributor from which your product was purchased. Tools required, but not limited to: flat head screwdriver, Phillips screwdriver, socket set, pliers, wire cutters.

### MAXXUM 70 FOOT PEDAL & CONTROL HEAD >

### > Foot Pedal & Control Head Parts Diagram

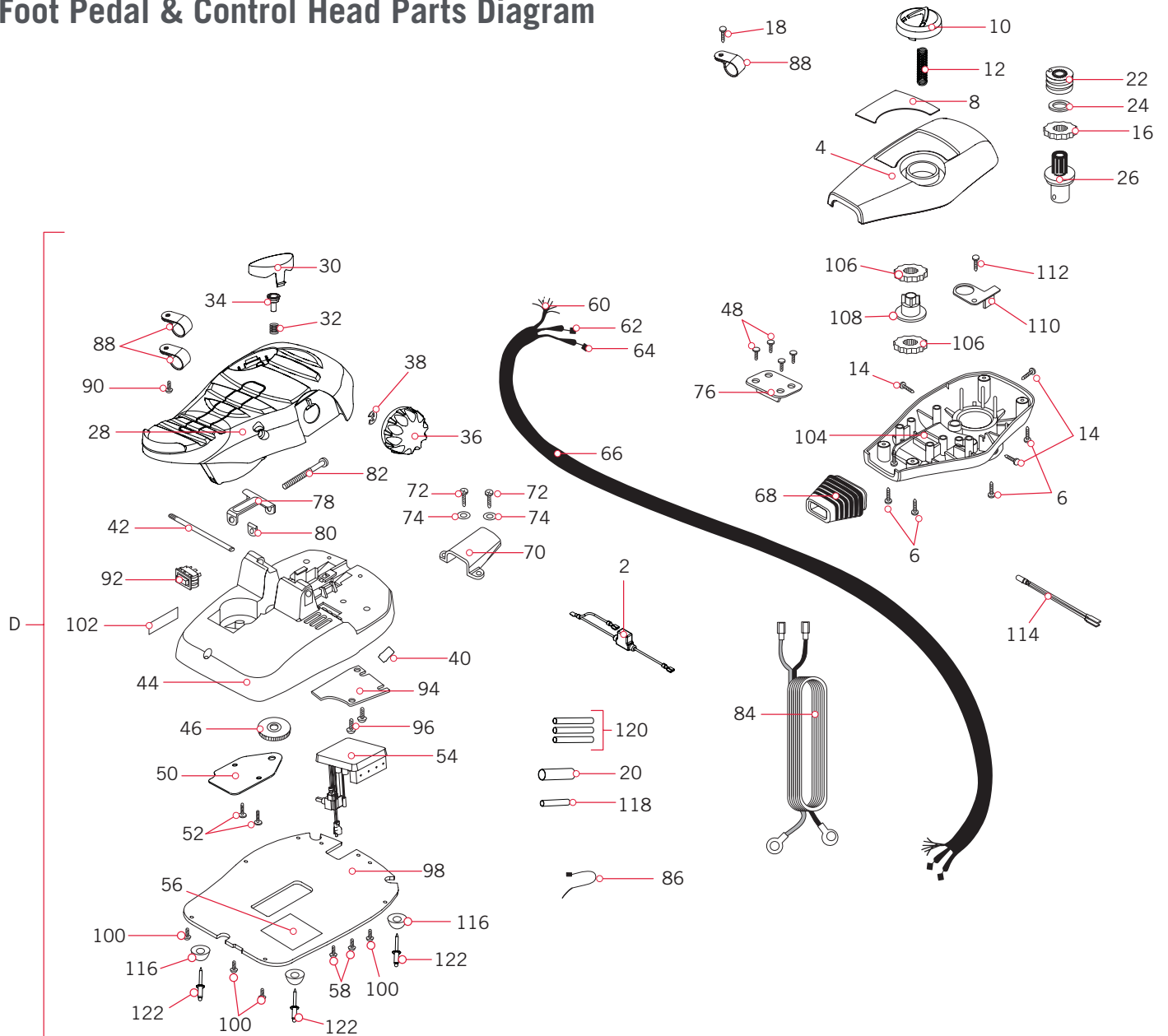

# PARTS DIAGRAM & PARTS LIST

## ► Foot Pedal & Control Head Parts List

Assembly	Part #	Description	Notes	Quantity
D	2992123	FT PED ASM, MAX 24/36V		1
Item	Part #	Description	Notes	Quantity
2	2218200	FUSE HOLDER ASSEMBLY		1
4	2280202	CONTROL BOX COVER, FTX,MAX/FC		1
6	2372100	SCREW-#8-18 X 5/8 THD* (SS)	NOT PART OF ASSEMBLY D	4
8	2265717	DECAL-COVER, MAX70/FC		1
10	2990140	INDICATOR ASSY		1
12	2282730	SPRING-INDICATOR		1
14	2053414	SCREW-#8-32 X 1/2 TRI-LOBE PPH	NOT PART OF ASSEMBLY D	3
16	2267800	GEAR-INDICATOR		1
18	2372100	SCREW-#8-18 X 5/8 THD* (SS)		1
20	2335400	SHRINK TUBE-1/2 OD X 2"		1
22	2232360	PULLEY-CABLE DRUM		1
24	2261730	WASHER-NYLON A/T CON B		1
26	2996247	TOP BEARING RACE/PINION DRIVE		1
28	2994497	FOOT PEDAL w/PLUG		1
30	2993705	PUSH BTTN/MAGNET ASSY		1
32	2302732	SPRING-LOWER PEDAL S/S		1
34	2260810	CLIP, REED SENSOR		1
36	2280115	KNOB-SPEED CTRL, VARS SPD		1
38	2263000	E-RING TRU-ARC#5133-43		1
40	2266413	TENSION SCREW PLATE FTPEDAL		1
42	2260511	PIN-PIVOT A/T FT PDL		1
44	2994556	ASSEMBLY, FT PEDAL BASE/PIN		1
46	2262301	PULLEY (FOOT PEDAL)		1
48	2223430	SCREW-#8x3/4 PPH,TYPE 25,SS		4
50	2266401	COVER-PULLEY (STAMPING)		1
52	2301310	SCREW-#8-18 X 1/2 (SS)*		2
54	2264056	CTRL BRD ASY-MX/FC 24/36V		1
56	2365107	INSULATING PAD(2.3 X 3.2)		1
58	2223455	SCREW-#10-32 X 1/2" ZP MACHINE		2
60	2261220	WIRE HARNESS, MAXXUM FT.PEDAL		1
62	2267505	CABLE ASSY-RIGHT (5')		1
64	2267515	CABLE ASSY-LEFT (5')		1
66	2265430	CABLE JACKET (5') AT MODEL		1
68	2265110	BOOT-CONTROL BOX		1

▲ Not shown on Parts Diagram.

✳ This part is included in an assembly and cannot be ordered individually.

# PARTS DIAGRAM & PARTS LIST



Item	Part #	Description	Notes	Quantity
70	2265115	BOOT-FOOT PEDAL BASE		1
72	2372100	SCREW-#8-18 X 5/8 THD* (SS)		2
74	2261714	WASHER-MAXXUM FT PDL 18/8 SS		2
76	2261901	BRACKET-CONDUIT AT/MAX		1
78	2263210	BRACKET-CONDUIT ADJUSTMEN		1
80	2263140	KEEPER-NYLOCK		1
82	2263466	SCREW-1/4-20 X 2" PPH SS/REI		1
84	2261238	LEADWIRE,MAX F.PED,61",SM TERM		1
86	2256300	TIE WRAP-5.5" BLACK		1
88	2263201	CLAMP WIRE HARNESS MICRO		3
90	2332103	SCREW-#6-20 X 3/8 THD*(SS)		1
92	2254031	SWITCH-MOM/OFF/COM		1
94	2266412	SWITCH PLATE, FT PEDAL		1
96	2332103	SCREW-#6-20 X 3/8 THD*(SS)		2
98	2264511	BOTTOM PLATE,MX101 FT PED		1
100	2372100	SCREW-#8-18 X 5/8 THD* (SS)		5
102	2266610	DECAL-ON/OFF SWITCH		1
104	2282500	CONTROL BOX , PLASTIC		1
106	2267800	GEAR-INDICATOR		2
108	2262221	INDICATOR-DRIVE (YELLOW)		1
110	2261905	BRACKET/INDICATOR		1
112	2301310	SCREW-#8-18 X 1/2 (SS)*		1
114	2264015	LIGHT/INDICATOR		1
116	2265126	BUMPER PAD, FOOT PEDAL		4
118	2375400	SHRINK TUBE-1/40D X 1-3/4		1
120	2355410	SHRINK TUBE-3/8 DIA. ID X 2"		3
122	2378600	RIVET-POP,3/16 X 3/4 ALUM.SHNK		4
▲	2267153	MANUAL-MAXXUM / FC		1
▲	2274961	PARTS LIST MAX70/FC-42"		1
▲	2015800	HANG TAG "CAUTION..TILT HINGE"		1
▲	2006809	PRODUCT LABELS,"CAUTION HEAVY"		1

▲ Not shown on Parts Diagram.

✘ This part is included in an assembly and cannot be ordered individually.



# PARTS DIAGRAM & PARTS LIST

## MAXXUM 70 MOTOR

### Motor Parts Diagram

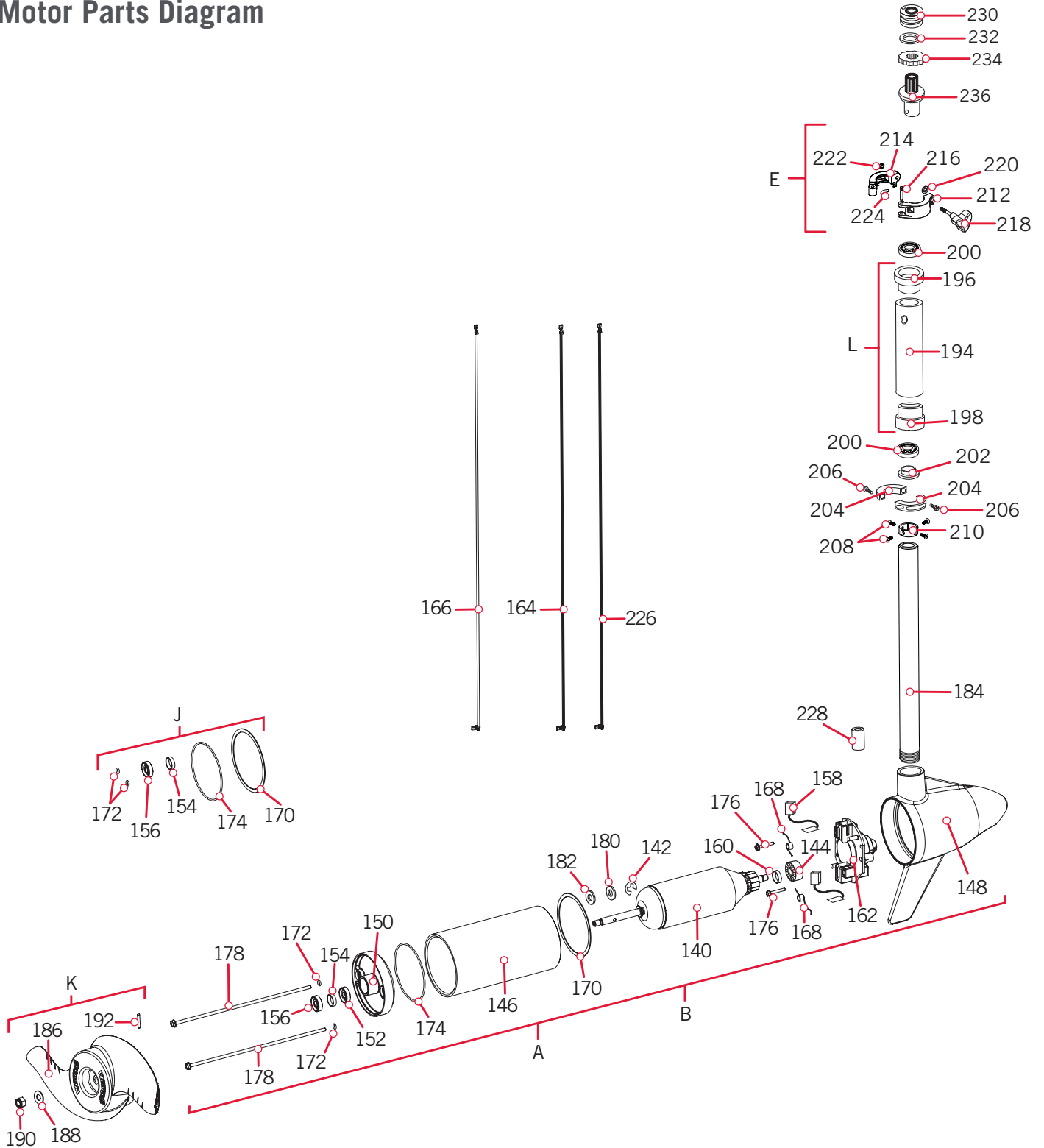

# PARTS DIAGRAM & PARTS LIST

## Motor Parts List

Assembly	Part #	Description	Notes	Quantity
A	2096067	MTR ASY 24V 3.62 VS 70#FW		1
B	2096060	MTR ASY 24V 3.62 VS 70#FW	W/O MOUNT	1
E	2991550	CLAMP COLLAR ASSY, MAXXUM		1
J	2888460	SEAL & O-RING KIT TURBO PRO		1
K	1378131	PROP KIT		1
L	2772012	TUBE W/BEARING RACE ASSY		1
Item	Part #	Description	Notes	Quantity
140	2-100-128	ARMATURE ASM 24V 3.62",70		1
142	788-015	RETAINING RING		1
144	140-010	BEARING - BALL		1
146	2-200-005	CTR HSG ASY 3.6 FW-MAGNET		1
148	421-065	HSG BRSH END 3.62 TXT FW		1
150	2-400-101A	PLAIN END HSG ASY 3.625		1
152	144-049	BEARING - FLANGE		1
154	880-003	SEAL		1
156	880-006	SEAL WITH SHIELD		1
158	188-038	BRUSH ASSEMBLY, 3.625", 70#		2
160	725-035	PAPER TUBE - SEAL BORE		1
162	738-038	BRUSH PLATE, 3.625", 70#		1
164	640-005	LEADWIRE BLK 10 AWG 57 GPT		1
	640-004	LEADWIRE BLK 10 AWG 56 GPT	W/O MOUNT	1
166	640-105	LEADWIRE RED 10 AWG 58 GPT		1
168	975-042	SPRING-TORSION, 70# LOWER UNIT		2
170	337-036	GASKET		1
172	701-008	O-RING	THRU-BOLT	2
174	701-081	O-RING		1
176	830-007	SCREW, # 8-32		2
178	830-008	THRU BOLT 10-32 x 9.205		2
180	990-067	WASHER - STEEL THRUST		1
182	990-070	WASHER - NYLATRON		1
184	2032003	TUBE COMP 42" (44.625")		1
186	2091160	PROP-WW2 (3 5/8") REAMED		1
188	2151726	WASHER-5/16 STD (S/S)		1
190	2053101	NUT-PROP,NYLOC (MED) 5/16 SS		1
192	2092600	PIN-DRIVE 1.06" LG (SS)		1
▲	810-001	RIVET-.25"		4

▲ Not shown on Parts Diagram.

✳ This part is included in an assembly and cannot be ordered individually.

# PARTS DIAGRAM & PARTS LIST



Item	Part #	Description	Notes	Quantity
194	2272069	TUBE OUTER-21" 4 HOLES		1
196	2266260	BEARING RACE		1
198	2266220	BEARING RACE-STEEL		1
200	2266000	BEARING BALL-STEEL		2
202	2266115	BEARING CONE		1
204	2261622	COLLAR HALF,ALUM (2 PER)		2
206	2263453	SCREW-1/4-20 X 1" SHCS S/S		2
208	2263457	SCREW-#8-32 X 3/8 PFH MACH		4
210	2071560	COLLAR-TUBE (4 HOLES)		1
212	2071550	COLLAR-CLAMP "A" SIDE		1
214	2071555	COLLAR-CLAMP "B" SIDE		1
216	2072621	PIN, KNURLED		1
218	2281505	KNOB-SOFT GRIP, FW		1
220	2071718	WASHER #10 NYLON RETAINING		1
222	2073102	NUT-HEX 1/4-28 SS		1
224	2075120	PAD,URETHANE,DEPTH COLLAR		1
226	640-315	LEADWIRE BROWN 18 AWG 62" GPT		1
228	2307314	BEAD-FERRITE	WITH MOUNT	1
230	2232360	PULLEY-CABLE DRUM		1
232	2261730	WASHER-NYLON A/T CON B		1
234	2267800	GEAR-INDICATOR		1
236	2996247	TOP BEARING RACE/PINION DRIVE		1

▲ Not shown on Parts Diagram.

✘ This part is included in an assembly and cannot be ordered individually.



# PARTS DIAGRAM & PARTS LIST

## MAXXUM 70 BOWGUARD

### Bowguard Parts Diagram

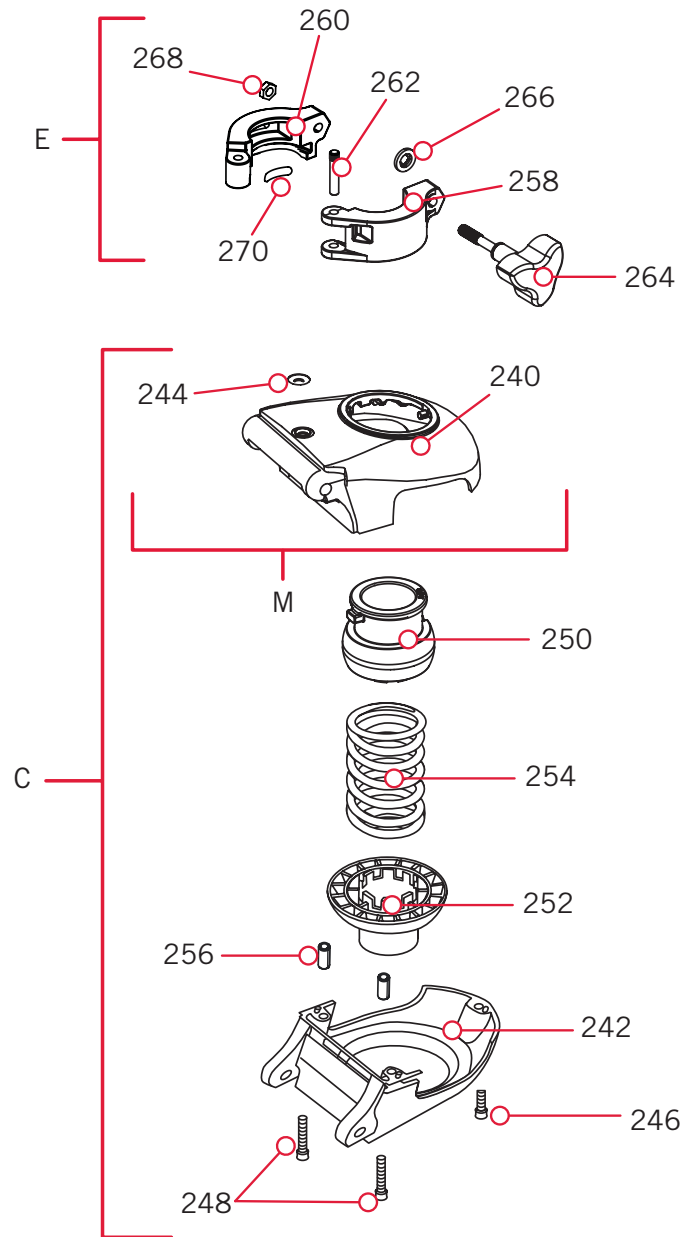

# PARTS DIAGRAM & PARTS LIST

## › Bowguard Parts List

Assembly	Part #	Description	Quantity
C	2991762	BOWGUARD ASY-FW,FC; HC W/3X	1
E	2991550	CLAMP COLLAR ASSY, MAXXUM	1
N	2772319	BRACKET BASE-TOP/EYELET FW	1
Item	Part #	Description	Quantity
240	2261943	BRACKET BASE TOP FW	1
242	2991776	BRACKET BTM/BEARING FW ASY	1
244	2262315	EYELET-ROPE,STAINLESS STEEL	1
246	2263423	SCREW-5/16-18 X 1" SHCS ZP	1
248	2263425	SCREW-5/16-18 X 2.5" SHCS ZP	2
250	2071541	SPRING-SLEEVE UPPER, MR C MAT'L	1
252	2071535	SPRING SLEEVE, LOWER	1
254	2262712	SPRING, BOWGUARD, FC PAINTED	1
256	2262632	PIN-SPRING 1/4" X 5/8" SS	2
258	2071550	COLLAR-CLAMP "A" SIDE	
260	2071555	COLLAR-CLAMP "B" SIDE	
262	2072621	PIN, KNURLED	
264	2281505	KNOB-SOFT GRIP, FW	
266	2071718	WASHER #10 NYLON RETAINING	
268	2073102	NUT-HEX 1/4-28 SS	
270	2075120	PAD,URETHANE,DEPTH COLLAR	

▲ Not shown on Parts Diagram.

✘ This part is included in an assembly and cannot be ordered individually.





# PARTS DIAGRAM & PARTS LIST

## Mount Parts List

Assembly	Part #	Description	Quantity
F	2991659	MNT ASM MAXXUM FW STD	1
G	2994830	BAG ASSY-MAXXUM	1
H	2881601	ROPE W/WASHER(40")MX MT	1
M	2999277	MTR REST ASM MAXXUM FW STD	1
P	2774315	ARM-LOWER ASSY FW STD.	1
Item	Part #	Description	Quantity
280	2264241	ARM-UPPER STD. FW, TX	1
282	2293501	BUSHING, STAINLESS STEEL	4
284	2263500	BOLT, SHOULDER (MAXXUM)	2
286	2994307	ARM-LOWER ASSY,STD,FW,EXT	1
288	2263916	MOTOR REST STD MAXXUM BLK	1
290	2265707	DECAL, MOTOR REST MAXXUM FW	2
292	2773987	BOWPLATE/INS ASY,STD,FW-TX	1
294	2251601	ROPE (44.5"), MAXXUM MNT	1
296	2267318	BUSHING,FLANGE,5/16 #5L7-F-642	2
298	2152612	SPRING-PIN (LOCKBAR) 18-8 SS	2
300	2233620	LOCK BAR-(BOW MNT) ZP CRS	1
302	2233622	LOCK BAR, REAR - ZP CRS	1
304	2152700	SPRING-(LOCKBAR) CAD.PLTD	1
306	2262703	SPRING STOP MAXXUM	1
308	2153602	EYE SHAFT-2LOCKBAR STD-PLTD	1
310	2260506	HINGE-PIN (HEADLESS)ZINC (N100	1
312	2293811	YOKE,MAX MNT-POLYPROPYLENE	1
314	2262605	PIN-BWGRD,UPPER,THREADED,ZP	1
316	2223100	NUT-5/16-18 NYLOCK S/S	2
318	9908236	WASHER-1/4 FLAT (ZINC)	2
320	2261505	SPACER, MOTOR REST	6
322	2263434	SCREW-#8-18 X 1" PPH S/S	2
324	2262607	PIN-CLEVIS,ZP,MAX BWGRD	1
326	2260805	CLIP-HAIR SPRING,ZP,MAX BG	1
328	2150400	PULL-GRIP	1
330	2151700	WASHER-EYE SHAFT(.562 OD) SS	1
332	2263431	SCREW-1/4-20 X 3.5 PPH	6
334	2261713	WASHER-1/4 FLAT 18-8 SS	6
336	2263103	NUT-1/4-20 NYLOCK SS	6
338	2261540	INSERT-THREADED,BOWPLT,MAX	2

▲ Not shown on Parts Diagram.

✳ This part is included in an assembly and cannot be ordered individually.

# MOTOR WIRING DIAGRAM

## MAXXUM VARIABLE SPEED

The following Motor Wiring Diagram applies to all Maxxum Foot Control models that come factory installed with Variable Speed Control.

Optional Brown Wire for Motors with 70 Lbs Thrust and Higher. See Boat Wiring Diagram.

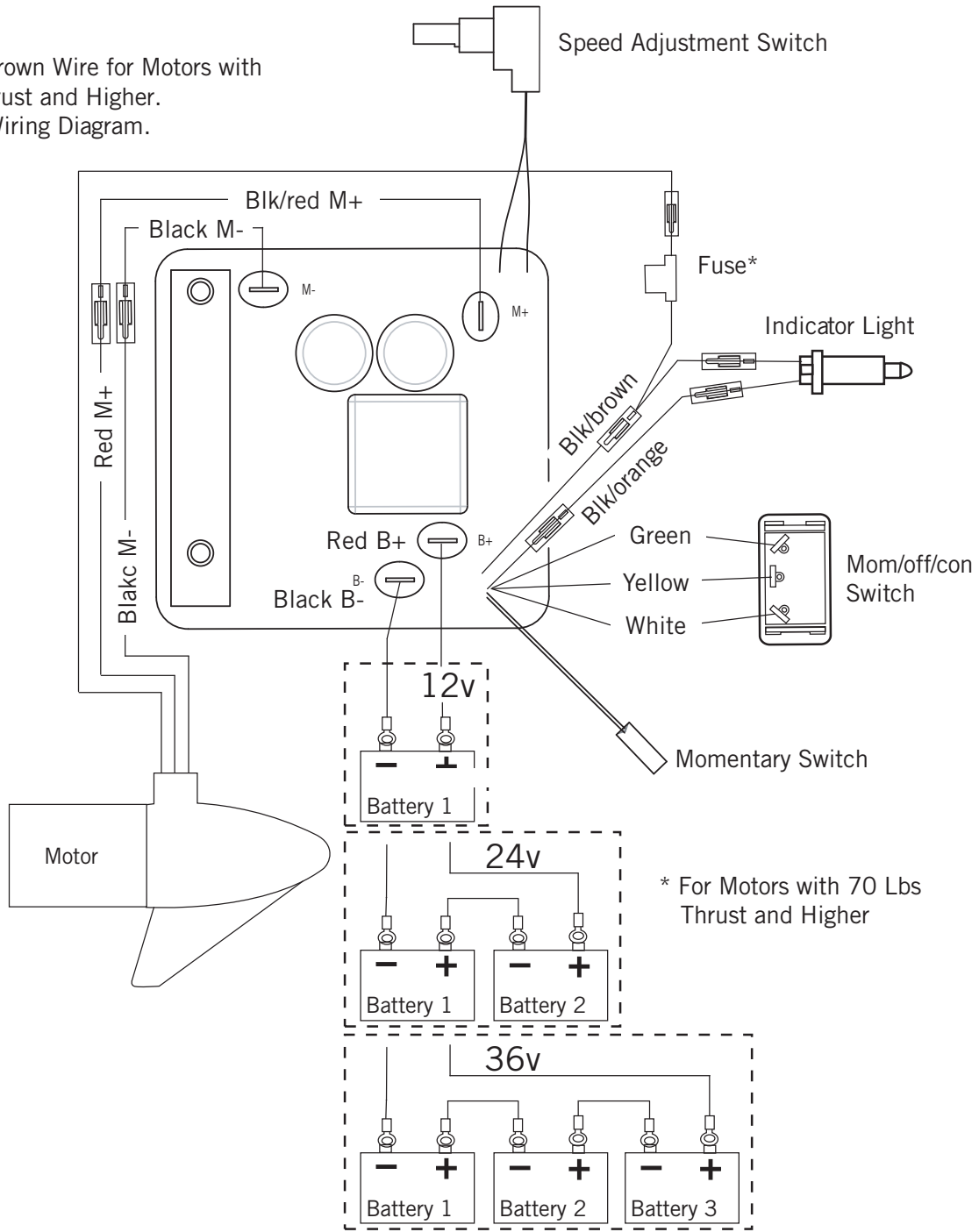

**NOTICE:** This is a multi-voltage diagram. Double-check your motor's voltage for proper connections. Over-Current Protection Devices are not shown in this illustration.