

MEGA LIVE IMAGING INSTALLATION GUIDE

532769-3_B



 **HUMMINBIRD**®

**Accessory
Manual**

Thank You!

Thank you for choosing Humminbird®, the #1 name in marine electronics. Humminbird has built its reputation by designing and manufacturing top-quality, thoroughly reliable marine equipment. Your Humminbird accessory is designed for trouble-free use in even the harshest marine environment. In the unlikely event that your Humminbird does require repairs, we offer an exclusive Service Policy. For complete details, see the separate warranty card included with your unit. We encourage you to read this manual carefully in order to get the full benefit from all the features and applications of your Humminbird product.

Contact Humminbird Technical Support through our Help Center at <https://humminbird-help.johnsonoutdoors.com/hc/en-us>.



WARNING! This device should not be used as a navigational aid to prevent collision, grounding, boat damage, or personal injury. When the boat is moving, water depth may change too quickly to allow time for you to react. Always operate the boat at very slow speeds if you suspect shallow water or submerged objects.



WARNING! The electronic chart in your Humminbird unit is an aid to navigation designed to facilitate the use of authorized government charts, not to replace them. Only official government charts and notices to mariners contain all of the current information needed for the safety of navigation, and the captain is responsible for their prudent use.



WARNING! Humminbird is not responsible for the loss of data files (waypoints, routes, tracks, groups, recordings, etc.) that may occur due to direct or indirect damage to the unit's hardware or software. It is important to back up your control head's data files periodically. See your control head operations manual for details.





WARNING! Disassembly and repair of this electronic unit should only be performed by authorized service personnel. Any modification of the serial number or attempt to repair the original equipment or accessories by unauthorized individuals will void the warranty.



NOTE: Some features discussed in this manual require a separate purchase. Every effort has been made to clearly identify those features. Please read the manual carefully in order to understand the full capabilities of your model.

 **NOTE:** The illustrations in this manual may not look the same as your product, but your unit will function in a similar way.

 **NOTE:** To purchase accessories for your control heads, visit our Web site at humminbird.com or Contact Humminbird Technical Support through our Help Center at <https://humminbird-help.johnsonoutdoors.com/hc/en-us>.

 **NOTE:** The procedures and features described in this manual are subject to change without notice. This manual was written in English and may have been translated to another language. Humminbird is not responsible for incorrect translations or discrepancies between documents.

 **NOTE:** Product specifications and features are subject to change without notice.

 **NOTE:** Humminbird verifies maximum stated depth in saltwater conditions, however actual depth performance may vary due to transducer installation, water type, thermal layers, bottom composition, and slope.

APEX™, Fortrex™, HELIX®, Humminbird®, Minn Kota®, SOLIX®, Ultrex™ are trademarked by or registered trademarks of Johnson Outdoors Marine Electronics, Inc.

© 2022 Johnson Outdoors Marine Electronics, Inc. All rights reserved.

Table of Contents

Introduction	1
Compatibility.....	1
Supplies.....	2
Update Software	3
Check the Current Software Version	3
Update Control Head Software with an SD Card.....	4
Update Accessory Software with an SD Card	5
Update Software with FishSmart.....	6
Install the Trolling Motor Mount	7
1. Prepare for Installation	7
2. Install the Landscape Mode Mount	8
3. Install the Shaft Mount	11
4. Install the Shaft Clamp.....	13
5. Route the Cables and Connect Power.....	15
Install the Choke Cable	20
1. Determine Whether to Install the Choke Cable.....	20
2. Install the Choke Cable.....	20
Set Up the Control Head	22
1. Confirm Connections	22
2. Set Up MEGA Live Imaging on the Control Head.....	25
3. Test MEGA Live Imaging on the Control Head.....	26
4. Confirm the Heading Sensor Operation	31
5. Confirm the Baud Rate (<i>for devices connected to Sensor pigtail only</i>).....	34
6. Set Up the Network	34
Power Off	35

Table of Contents

Maintenance	36
Control Head Maintenance.....	36
Transducer Maintenance	37
MEGA Live Imaging Maintenance.....	37
Troubleshooting	38
"Out of Water" Error Display when MEGA Live Is in the Water	38
Fishing System Doesn't Power Up	39
Fishing System Defaults to Simulator with a Transducer Attached	39
Finding the Cause of Noise	40
Specifications	41
Contact Humminbird	44

Introduction

This manual will guide you through the following installation requirements for the MEGA Live Imaging transducer:

- Installing the Transducer
- Connecting to the Control Head and Power
- Testing the Installation
- Powering Off

Before proceeding with this installation, the Humminbird control head and Minn Kota trolling motor should be installed. The MEGA Live Imaging transducer can be connected directly to the control head or to a Humminbird Ethernet Switch (optional, separate purchase required) for networking. See the Ethernet Switch installation instructions to install the Ethernet Switch.

Compatibility

Control Heads: MEGA Live Imaging is compatible with all APEX™ Series and SOLIX® Series fish finders, HELIX® Series G3N and G4N fish finders equipped with MEGA Imaging+, and HELIX 7 G4N fish finders with MEGA Down Imaging or MEGA Side Imaging. It can be mounted on all Minn Kota Ultrex trolling motors and on Minn Kota Fortrex trolling motors with built-in MEGA DI.

Minn Kota Trolling Motor	Humminbird Fish Finder
Minn Kota Ultrex (all models)	APEX Series: All models
Minn Kota Fortrex (Built-In MEGA DI models only)	SOLIX Series: All models HELIX Series: HELIX G3N and G4N models with MEGA Imaging+ and HELIX 7 G4N models with MDI or MSI



NOTE: You must have a GPS heading sensor (compass) installed in order to use the MEGA Live Imaging navigation features.

Cables: Your MEGA Live Imaging transducer comes with the cables required to connect directly to your Humminbird fish finder. In addition to the cables permanently attached to the transducer, this includes two extension cables (a 10' MEGA Live power cable and a 20' Ethernet cable) to allow for quick-disconnect. To connect the Ethernet to a HELIX control head, you will need to purchase an ethernet adapter cable.



NOTE: An ethernet switch (separate purchase required) can be used to connect your MEGA Live Imaging transducer to multiple control heads. To purchase accessories for your control heads, visit our Web site at humminbird.com or Contact Humminbird Technical Support through our Help Center at <https://humminbird-help.johnsonoutdoors.com/hc/en-us>.

Accessories: Additional recommended accessories include a Humminbird Heading Sensor GPS Puck (and a Heading Sensor GPS Adapter cable for APEX and SOLIX only), or a Minn Kota Heading Sensor connected to an i-Pilot Link trolling motor. For the most current list of compatible accessories, visit our Web site at humminbird.com.

Supplies

In addition to the hardware included with your accessory, you will need the following supplies:

- Cable ties for cable routing
- 2 Amp fuse
- Multi-bit screwdriver

Switch (optional): If you do not have a main switch or fuse panel available on your boat to connect power, you will need to purchase a battery switch. See *Install the Trolling Motor Mount, Section 5: Route the Cables and Connect Power* for more information.

Update Software

Your control head model may need a software update to work with the MEGA Live Imaging transducer. We recommend that you read the following section completely before starting any software updates.



NOTE: It is important to install the latest software update on your control head to enable all MEGA Live features. For the latest software update, visit our Web site at humminbird.com.

Check the Current Software Version

It is helpful to review the software version number that is currently installed on the control head and each accessory.

APEX/SOLIX Series

1. Press the HOME key.
2. Select Settings.
3. Select Network > Network Info.
4. The Network Info dialog box shows a section for each device connected to the network. Scroll to each section to note the software version number listed.

HELIX Series

1. Press and hold the VIEW key.
2. Select System > System Status.
3. Confirm the Software Version listed.

Update Control Head Software with an SD Card

You will need an SD or microSD card (depending on your control head model).



WARNING! Humminbird is not responsible for the loss of data files (waypoints, routes, tracks, groups, snapshots, recordings, etc.) that may occur due to direct or indirect damage to the unit's hardware or software. It is important to back up your control head data files periodically. See your control head operations manual for more information.

1. Before the control head software is updated or restored to system defaults, export your navigation data and copy your screen snapshots to an SD or microSD card. See your control head operations manual for instructions.
2. Install a formatted SD or microSD card into the computer card slot.
3. Go to **humminbird.com**, and click Support > Software Updates.
4. Click on your control head model. The available software updates are listed as downloads under each product. Confirm the file name is for your control head model.
 - Read the notices and instructions, and select Download.
 - Follow the on-screen prompts to save the software file to the SD or microSD card.
5. Repeat step 4 to download the software updates posted to each product.
6. Insert the SD or microSD card (with the software file) into the control head card slot.
7. Power on your Humminbird control head. Start **Normal** mode.
8. Follow the on-screen prompts to update the control head software.
9. When the software update is complete, remove the SD or microSD card from the control head card slot.
10. **Restart:** If you don't have any other software updates to install, power off the control head, and restart it.

Update Accessory Software with an SD Card

You will need an SD or microSD card (depending on your control head model).

1. Install a formatted SD or microSD card into the computer card slot.
2. Go to **humminbird.com**, and click Support > Software Updates.
3. Scroll down to Accessories and Mapping. The available software updates are listed as downloads under each accessory product. Confirm your control head model is listed in the software description.
 - Read the notices and instructions, and select Download.
 - Follow the on-screen prompts to save the software file to the SD or microSD card.
4. Insert the SD or microSD card (with the software file) into the control head card slot.
5. Power on your Humminbird control head. Start **Normal** mode.
6. **APEX/SOLIX:** Select the Files tool. From the Software Update tab, scroll to MEGA Live on the Accessories list. Confirm that the most current software version is selected from the list, and select Install Now.
HELIX: The software will be automatically detected. The control head will display a dialog box to indicate that it has detected the software. It may take several minutes for the control head to update, and you will briefly lose sonar returns as the update completes.
7. When the software update is complete, remove the SD or microSD card from the control head card slot.
8. **Restart:** If you don't have any other software updates to install, power off the control head, and restart it.

Update Software with FishSmart

You can use the FishSmart App to download and push software updates directly to your Humminbird control head or accessory.



NOTE: It is important to install the latest software update on your control head to enable all FishSmart features. For the latest software update, visit our Web site at humminbird.com.



NOTE: You must first download the FishSmart App and pair your mobile device to your control head. See the *FishSmart User Manual* for more information.

1. Open the FishSmart App on your mobile device.
2. **Apple iOS:** Tap the System menu icon.
Google Android: Tap the FishSmart main menu. Select system.
3. Tap Update next to the selected unit. The download progress is displayed on the screen.
4. Tap Transfer next to the selected unit once the download is complete.
5. Confirm the estimated transfer time.
6. Tap the checkbox to select where to upload the software update (internal storage, card slot 1, or card slot 2).



NOTE: For APEX and SOLIX Series control heads, you cannot download software updates to an SD or microSD card with LakeMaster charts saved to it.

7. Tap Transfer. The upload progress is displayed on the System menu in FishSmart and in the System Status view on the control head.
8. Follow the on-screen prompts on the control head to complete the software installation.

Install the Trolling Motor Mount

Use the following instructions to install the MEGA Live Imaging transducer on your Minn Kota trolling motor. It is important to read the instructions completely and understand the mounting guidelines before you start the installation.

1. Prepare for Installation

1. The trolling motor should be in the fully retracted (flat) position on the boat deck for this installation.
2. Disconnect the motor from all sources of electrical power.
3. Test run the Ethernet cable from the chosen mounting location on the trolling motor to the control head or ethernet switch. Test run the power cable from the chosen mounting location on the trolling motor to the main switch or fuse panel.

It is important to consider the following:

- The MEGA Live Imaging transducer is powered separately from the control head. It must be connected to a switch where it can be powered on when the boat is underway and powered off when it is docked.
 - The cables should be routed through an established routing system on the boat, in an area with minimal interference, without sharp edges, obstacles, or obstructions that may damage the cables.
 - The cables will move with the trolling motor when it is deployed and retracted, so it is important to allow enough length for movement.
4. With the trolling motor deployed, the transducer has the following installation requirements:
 - The transducer should not have anything obstructing the 'view' of the beams. If possible, move anything to the sides and below the transducer that might obstruct the sight line of the beams.

2. Install the Landscape Mode Mount

Use the following instructions to install the Landscape Mode mount onto the transducer.

Landscape Mode Mount

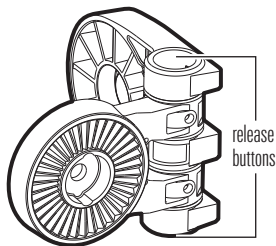

1. The Landscape Mode mount should be open for this step of the installation. Unlock the mount by pressing down on the two release buttons, and pull the mount open. It will relock automatically once fully opened.
2. In addition to the requirements listed in the *Prepare for Installation* section, determine if the transducer will be installed on the left or right side of the trolling motor.

If the trolling motor stows on the right (starboard) side of the boat, you will mount the transducer on the right side of the trolling motor.

If the trolling motor stows on the left (port) side of the boat, you will mount the transducer on the left side of the trolling motor.

Port Installation

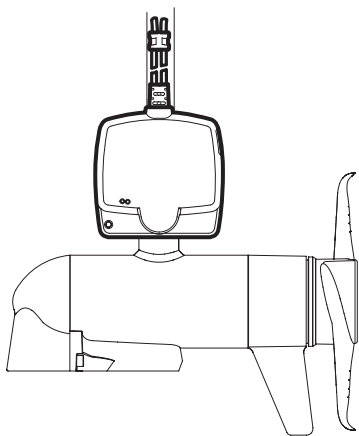

Starboard Installation

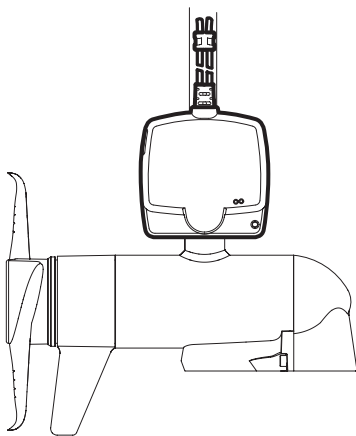

3. With the transducer face down and its cables pointed away from you, determine how the Landscape Mode mount should align with the transducer.

Recommended Configuration: Align the mount with the hinge on the left for a Port installation or on the right for a Starboard installation (see the illustration *Positioning the Landscape Mode Mount*).



NOTE: Your transducer will flip up for landscape mode when installed in the Recommended Configuration. If you prefer to flip your transducer down for landscape mode (see the illustration *MEGA Live Views* in *Section 5. Route the Cable and Connect Power*), use the Optional Configuration.

Optional Configuration: Align the mount with the hinge on the right for a Port installation or on the left for a Starboard installation (see the illustration *Positioning the Landscape Mode Mount*).

Positioning the Landscape Mode Mount

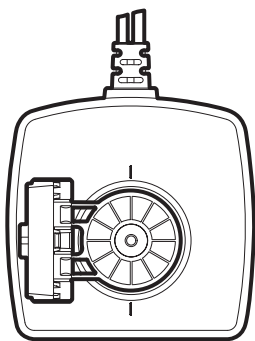

Hinge on Left

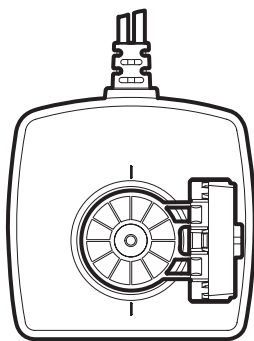

Hinge on Right

4. Connect the Landscape Mode mount to the transducer according to your Recommended or Optional configuration.

The ratchets are keyed to allow for Port or Starboard installation. The ribs on the Landscape Mode mount ratchet should align with the marks on your transducer.

Connecting the Landscape Mode Mount to the Transducer

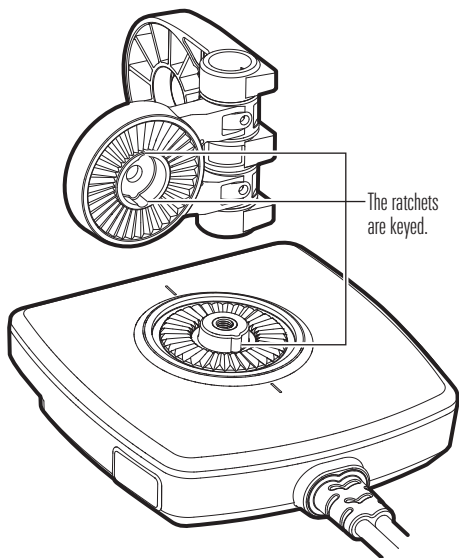

5. Secure the Landscape Mode mount to the transducer with one of the included lock washers and 1/4-28 screws, using the provided hex bit. Hand tighten the screw until the lock washer is fully compressed (see the illustration *Compressing the Lock Washer*), and then tighten an additional 1/4 turn. **Hand tighten only!**



WARNING! The screw and lock washer **MUST** be fully tightened. Failure to do so may result in the transducer detaching from the Landscape Mode mount in the water.

Compressing the Lock Washer

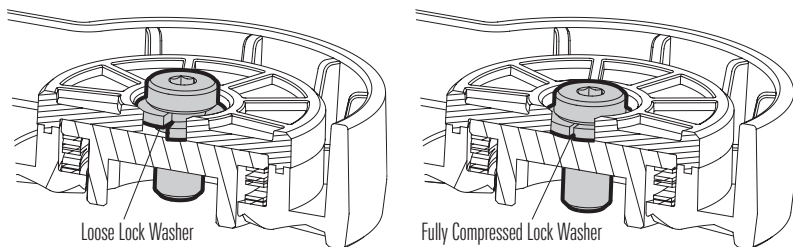

3. Install the Shaft Mount

1. Fold the Landscape Mode mount back down using the release buttons.
2. **For installation on a Fortrex trolling motor**, secure the included small rubber pads to the inside of the shaft mount as shown in the illustration ***Shaft Mount Rubber Pad Placement***. Remove the backing from the pads and press the adhesive sides firmly into place against the shaft mount.

Shaft Mount Rubber Pad Placement

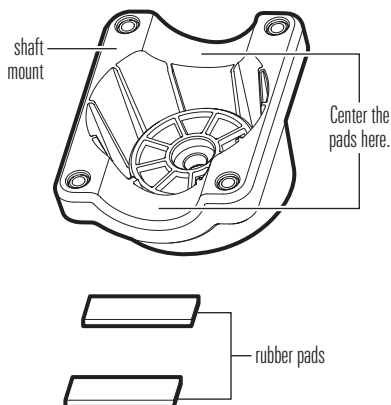

For installation on an Ultrex trolling motor, rubber pads are not needed. Proceed to Step 3.

- Align the keys on the shaft mount and the Landscape Mode mount to connect them.

Connecting the Shaft Mount to the Landscape Mode Mount

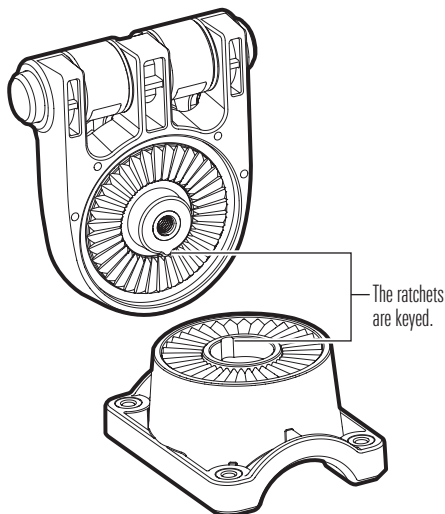

- Secure the shaft mount with one of the included lock washers and 1/4-28 screws, using the provided hex bit. Hand tighten the screw until the lock washer is fully compressed (see the illustration *Compressing the Lock Washer*), and then tighten an additional 1/4 turn. **Hand tighten only!**



WARNING! The screw and lock washer **MUST** be fully tightened. Failure to do so may result in the Landscape Mode mount detaching from the shaft mount in the water.

- Rotate the shaft mount until it is aligned vertically with the transducer.

4. Install the Shaft Clamp

WARNING! Disconnect the motor from all sources of electrical power before you start installation.

WARNING! Confirm that the trolling motor is properly secured to the boat and will not shift during the installation.

1. The trolling motor should be in the fully retracted (flat) position on the boat deck for this installation.
2. Disconnect the motor from all sources of electrical power.

3. **For installation on a Fortrex trolling motor**, secure the included large rubber pad to the inside of the shaft clamp as shown in the illustration ***Shaft Clamp Rubber Pad Placement***. Remove the backing from the pad and press the adhesive side firmly into place against the shaft clamp.

For installation on an Ultrex trolling motor, the rubber pad is not needed. Proceed to Step 4.

4. With the trolling motor stowed, align the shaft mount and shaft clamp around the base of the trolling motor shaft.

Optional: The transducer can be installed farther up the trolling motor shaft if desired.

5. Secure the shaft clamp to the shaft mount by installing the (4) #10-32 screws into the threaded holes on the clamp using the provided 5/32" Allen wrench. Do not fully tighten.

**Shaft Clamp
Rubber Pad Placement**

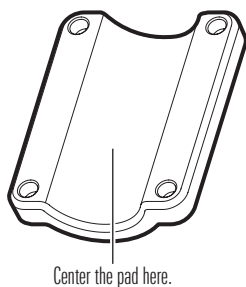

6. Rotate the MEGA Live Imaging transducer around the shaft until it is parallel with the lower unit of the trolling motor (see *Aligning the Transducer*). This ensures the transducer is pointing in the same direction as the trolling motor.

Aligning the Transducer

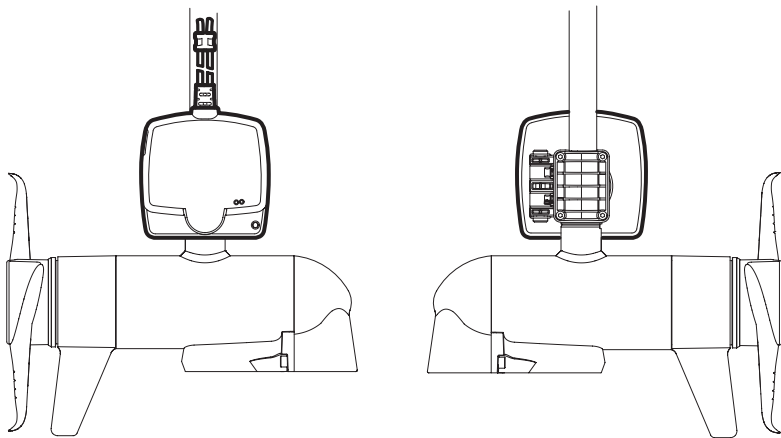

7. Fully tighten the screws until the transducer cannot be moved on the shaft.
Hand-tighten only!

5. Route the Cables and Connect Power

WARNING! The power source must be turned off before you proceed with this installation.

Molded Anchor Point

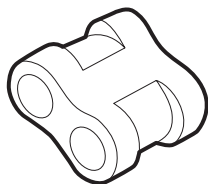

1. Position the first molded anchor point 4-5 inches from the top of the mount. Secure it with a cable tie. Do not fully tighten.

CAUTION! To avoid damaging the cables, apply cable ties **ONLY** at the designated anchor points.

2. Rotate the transducer by hand to test the Down, Forward and Landscape Mode views as illustrated in *MEGA Live Views* to ensure proper slack in the cables. Your trolling motor mount includes guides to help you position the transducer correctly (see the illustration *MEGA Live Mode Guides*).

To alternate between Down and Forward views, rotate the transducer on its mount using both hands.

To change from Down or Forward view to Landscape Mode, press the two release buttons on the hinge until the mount unlocks. Flip the transducer out until the hinge locks.

To adjust the Landscape Mode angle, rotate the transducer on its mount using both hands.

MEGA Live Mode Guides

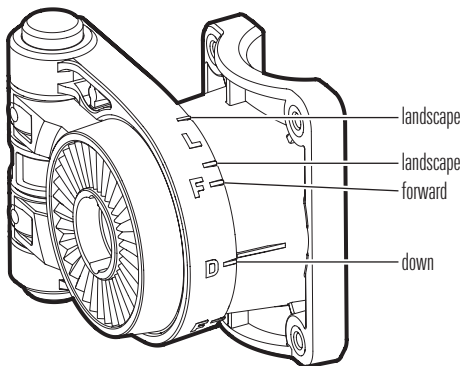

MEGA Live Views

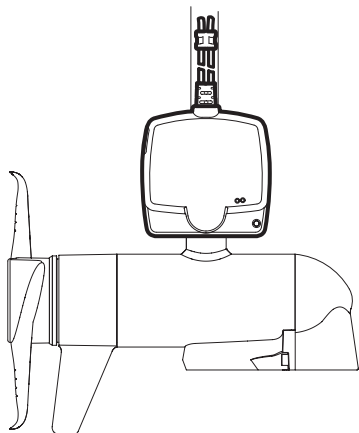

Down View

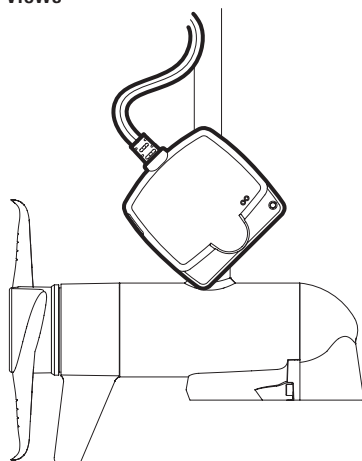

Forward View

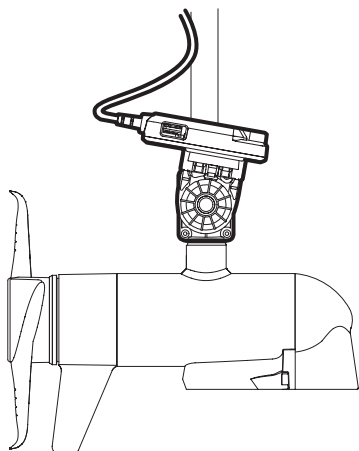

Recommended Landscape Mode

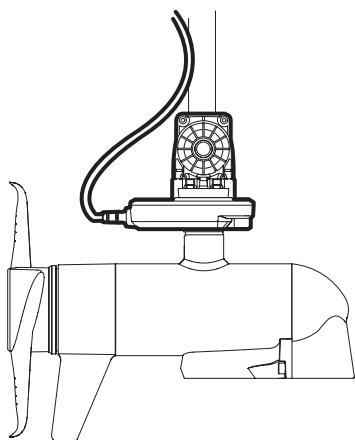

Optional Landscape Mode

3. Adjust the first anchor point as needed and then fully tighten the cable tie.

- Secure the remaining anchor points with cable ties as you route the cables up the trolling motor shaft.

Depending on your installation configuration and motor's shaft length, you may not need all five anchor points.

- Route the rest of the cables to the side of the trolling motor, over the bow, to the chosen connection locations in **Section 1: Prepare for Installation**. Leave sufficient slack in the cables to allow for full movement of the trolling motor during normal operation (see **Routing the Cables**).

Routing the Cables

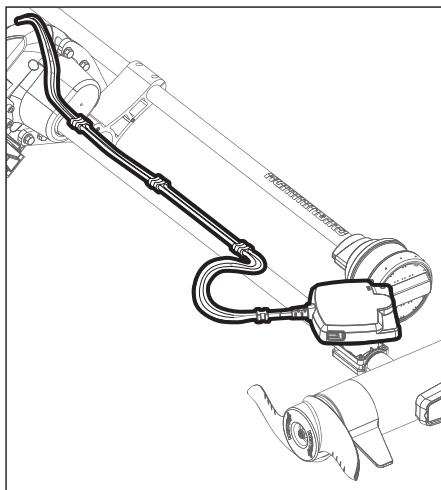

CAUTION! Do NOT mount the cables where the connectors could be submerged in water or flooded. If cables are installed in a splash-prone area, it may be helpful to apply dielectric grease to the inside of the connectors to prevent corrosion. Dielectric grease can be purchased separately from a general hardware or automotive store.

NOTE: The cables should be routed through an established routing system on the boat, in an area with minimal interference. Inspect the selected route carefully to ensure that there are no sharp edges, obstacles, or obstructions that may damage the cables. **Avoid pinch points created by stowing or deploying the trolling motor.**



NOTE: You must ensure your MEGA Live ethernet and power wires are installed in a location where they will not be cut or ripped by the trolling motor articulating or rotating. Wires damaged by improper installation are **NOT** covered by the product warranty.

- Ethernet:** Insert the Ethernet Cable into the Ethernet port on the control head. Hand-tighten the screw nut.



NOTE: If you have a HELIX Series unit with Ethernet, connect the Ethernet Cable to an Ethernet Adapter Cable (AS EC QDE, separate purchase required). Insert the connector into the Ethernet port on the control head or cable tray. See your control head installation guide for details.

Hand-tightening the Screw Nut



The connectors are keyed to prevent reversed installation.

HELIX G3N 8, 9, 10, 12 Cable Tray

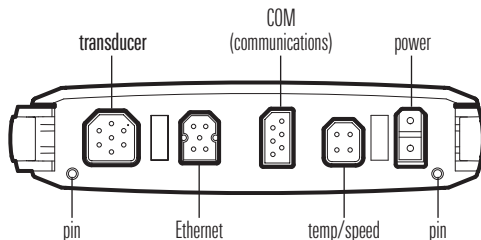

HELIX G4N 8, 9, 10, 12, 15 Cable Tray

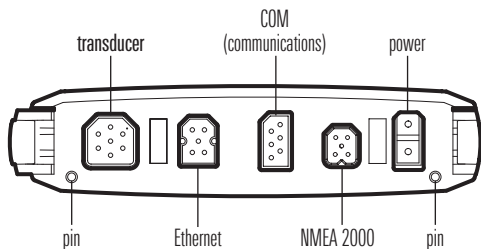

- Power:** Route the power cable to the main switch or fuse panel (usually located near the console). If you must connect to a battery, connect to a battery switch (not included).



WARNING! The MEGA Live Imaging transducer should be connected to a main switch, fuse panel, or battery switch. Humminbird does not recommend connecting to a battery without a fuse and a switch.



CAUTION: Some boats have 24 or 36 Volt electric systems, but the MEGA Live Imaging transducer **MUST** be connected to a 12 VDC power supply.



NOTE: Humminbird is not responsible for over-voltage or over-current failures. The MEGA Live Imaging transducer must have adequate protection through the proper selection and installation of a 2 Amp fuse.



NOTE: A 10' (3 m) power cable is included to supply power to the MEGA LIVE Imaging transducer. You may shorten or lengthen the cable using 12 gauge multi-stranded copper wire.

- 8a. **Main Switch/Fuse Panel:** If a fuse terminal is available, use crimp-on type electrical connectors (not included) that match the terminal on the fuse panel. Attach the black wire to ground (-), and the red wire to positive (+) 12 VDC power, and the drain/shield wire to the boat's chassis ground terminal. Install a 2 Amp fuse (not included) for protection of the unit.

Connecting to the Fuse Panel

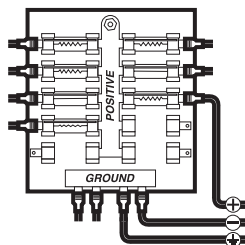

OR

- 8b. **Battery Switch:** Install the battery switch (not included) using the instructions provided with it. You will also need to obtain and install an inline fuse holder and a 2 Amp fuse (not included) for the protection of the unit. Attach the black wire to ground (-), the red wire to positive (+) 12 VDC power, and the drain/shield wire to the boat's chassis ground terminal.



WARNING! If you are unable to obtain a battery switch and are forced to connect the power cable directly to the battery, be aware that this will drain the battery. Humminbird does not recommend connecting to a battery without the appropriate fuse and a switch.



NOTE: The drain/shield wire is the non-tinned black wire.

9. Secure the cables along the route as needed for a clean assembly.

Install the Choke Cable

Reduce noise interference (if needed) using the included choke cable.

1. Determine Whether to Install the Choke Cable

If an on-board charger is present and attached to the cranking battery, install the choke cable (included) to reduce noise interference in the transducer.

If there is not an on-board charger connected to the cranking battery, the choke cable is not required.

2. Install the Choke Cable

Use the following instructions to install the choke cable.

Supplies: Wire cutter, wire stripper, wire crimper, safety glasses, protective gloves, and a heating agent.

⚠ WARNING! Disconnect the power source for all related equipment before you start the installation.

1. Disconnect the on-board charger from the main power source.
2. Disconnect the charger cable from the cranking battery.
3. Use a wire cutter to cut the charger cable between the fork in the output cable and the fuse holder. The fuse holder should always remain within 7" of the battery terminals.

Cutting the Charger Cable

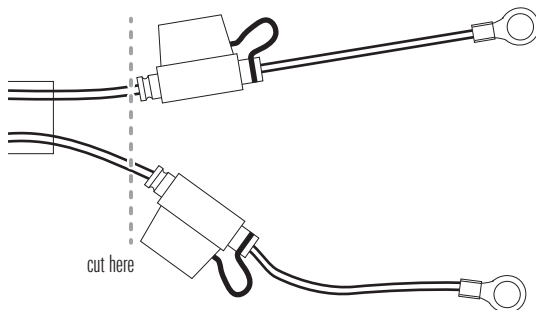

4. Strip back the shield on each end of the cut wires approximately 1/4 inch (6.4 mm).
5. Connect the stripped wires of the charger cable to the butt connectors on the choke cable (red to white and black to black).
6. Securely crimp the wires in the butt connectors.
7. Apply heat over the splice connection shrink insulation to secure the connection.



WARNING! Use extreme caution when applying heat to the shrink insulation.

8. Connect the terminals on the charger cable to the cranking battery.

Set Up the Control Head





Use the following instructions to power on the control head and confirm the MEGA Live Imaging transducer and the GPS Heading Sensor are detected by the unit.





 **CAUTION!** It is important to finish all installation connections before powering on the control head. It may take up to a minute for the MEGA Live Imaging transducer and other attached equipment to be detected by the control head.

1. Confirm Connections

APEX/SOLIX Series

1. Turn on the power source from the main switch.
2. On the control head, press and hold the POWER key. **If you are powering on a control head in a multiple-control head Ethernet network**, power on the control head that is connected to the MEGA Live Imaging transducer first.
3. Select Normal mode.
4. Review the status bar in the top, right corner of the screen to confirm the sensor status for the MEGA Live Imaging transducer and the GPS Receiver/Heading Sensor is connected.

MEGA Live Status Icon	Icon Description
	Connected/In Water/Pinging: The MEGA Live is connected, in the water, and pinging.
	Connected/In Water/Not Pinging: The MEGA Live is connected and in the water, but it is not pinging.
	Connected/Out of Water: The MEGA Live is connected, but the wet indicator is out of the water.
	Connection Lost: The connection to the MEGA Live was lost.

GPS Heading Sensor Icon	Icon Description
	Compass: The selected heading sensor is on and heading data is being received.
	Detected and Active: The GPS receiver is detected and a GPS fix has been obtained.
	Connected but not Detected or Active: The GPS receiver is connected, but not detected on the network or no GPS fix has been obtained.
	Connected but not Transmitting/Receiving: The GPS receiver is detected, but it doesn't have a GPS fix.



NOTE: For additional system status, select Home > Settings > Network > Network Info.

MEGA Live Imaging Transducer Connected (APEX/SOLIX)

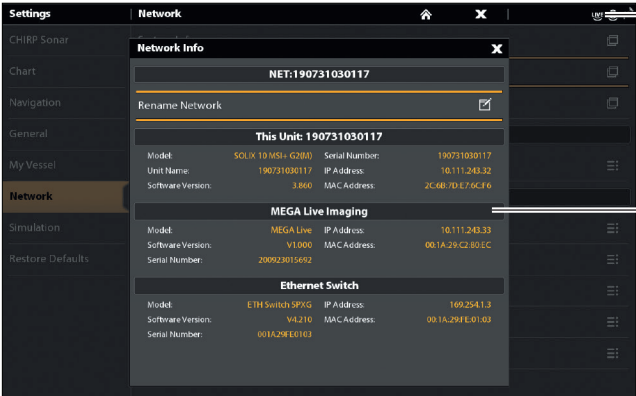

The screenshot shows the 'Network Info' settings page. It lists three network devices:

- NET:190731030117** (Rename Network)
- This Unit: 190731030117**
 - Model: SOLIX 10 (MS) - G280
 - Serial Number: 190731030117
 - Unit Name: 190731030117
 - IP Address: 10.111.243.32
 - Software Version: 3.860
 - MAC Address: 2C-6B-7D-E7-6C-F6
- MEGA Live Imaging**
 - Model: MEGA Live
 - IP Address: 10.111.243.33
 - Software Version: V1.000
 - MAC Address: 00:1A:29:C2:80:EC
 - Serial Number: 200923015692
- Ethernet Switch**
 - Model: ETH Switch SPKG
 - IP Address: 169.254.1.3
 - Software Version: V4.2.10
 - MAC Address: 00:1A:29:FE:01:03
 - Serial Number: 001A29FE0103

Annotations on the right side of the screenshot:

- An arrow points to the 'NET:190731030117' header with the text: "MEGA Live icon on the status bar".
- An arrow points to the 'MEGA Live Imaging' section with the text: "MEGA Live Imaging listed".

HELIX Series

1. Turn on the power source from the main switch.
2. On the control head, press the POWER key. **If you are powering on a control head in a multiple-control head Ethernet network**, power on the control head that is connected to the Mega Live Imaging transducer first.
3. When the Title screen is displayed, press the MENU key.
4. Select Normal. Press the RIGHT Cursor key.
5. Press and hold the VIEW key. Select System > Accessory Test. Confirm that **Mega Live** and **GPS + Heading Sensor** are listed as Connected. It will take a minute for the equipment to be detected.
6. Press and hold the VIEW key. Select System > GPS Diagnostic View. Confirm that External GPS is displayed and the Fix Type indicates Enhanced or 3D.



NOTE: If the GPS Diagnostic View or Accessory Test is not displayed in the View Rotation, press the MENU key twice to open the Main Menu. Select the Views tab > GPS Diagnostic View or Accessory Test. Change the setting for each view to Visible.

HELIX Accessory Test

Accessory Test	
Depth 41.4 ft	360 Imaging UNCONNECTED
Temp. 1 35.1 °F	BT Talon UNCONNECTED
N 34.19530° W 083.99157°	GPS + Heading Sensor CONNECTED
Time 11:31 AM	I-Pilot BT v9.999 CONNECTED
Speed 5.6 mph	MEGA 360 Imaging UNCONNECTED
5:06 am	MEGA Live v0.011 S/N: 200923015692 CONNECTED
1.9 0.4 mph	NIMEA 2000 CONNECTED
VLT 13.4 V	CHIRP-Radar CONNECTED
	Speed CONNECTED
	Temperature CONNECTED

GPS Heading Sensor listed as Connected

MEGA Live Imaging listed as Connected

GPS Diagnostic View

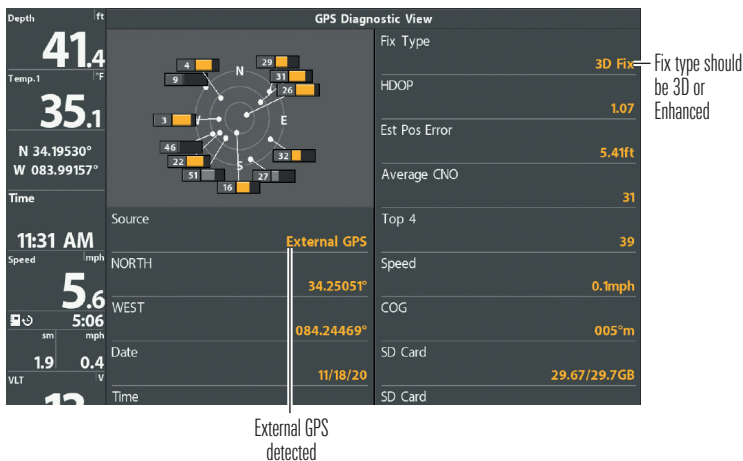

2. Set Up MEGA Live Imaging on the Control Head

APEX/SOLIX Series



Your APEX or SOLIX control head will automatically detect and subscribe to MEGA Live Imaging. To review the selected sonar sources, open the Settings tool, and select CHIRP Sonar > Sonar Source.

HELIX Series

Your HELIX control head will automatically detect and subscribe to MEGA Live Imaging. Use the following instructions to confirm that MEGA Live is selected in the Network Source Setup dialog box. It might take up to a minute for the equipment to be detected.

1. **Main Menu:** Press the MENU key twice.
2. Select the Network tab > Network Source Setup. Press the RIGHT Cursor key.
3. Select the Live tab from the Network Source Setup dialog box.
4. Select MEGA Live from the transducer list. Press the RIGHT Cursor key. A checkmark will display in the box to show it is selected.
5. Press the EXIT key until the dialog box is closed.

Selecting the MEGA Live Imaging Transducer

Network Source Setup						
Status	2D	DI	Live	T1	T2	GPS
Name	Model			kHz		
zynq	MEGA Live Sonar		MEGA Live	MULTIBEAM 		

3. Test MEGA Live Imaging on the Control Head

It is important to confirm that the MEGA Live Imaging transducer is providing sonar returns to the display. The instructions in this section should be performed at trolling speeds in calm, open water, in a large area that is far from shallow water, boats, or other obstacles.

APEX/SOLIX Series

1. Tap the View widget icon in the side bar.



NOTE: Once the MEGA Live has been detected the first time, the MEGA Live Imaging view will display on the Favorite Views widget.

2. Tap MEGA Live Imaging.
3. The sonar returns from the MEGA Live scan will begin to display on the MEGA Live View. Review the display for the following information and see the illustrations *Reviewing the MEGA Live View*.
 - **Bottom:** Confirm that the bottom is visible on-screen.
 - **Blocked Beams:** If the beams hit a hard surface, it will appear as bright white on the display. If the beams are blocked by any objects, move the objects if possible. You can also adjust the MEGA Live Range on the X-Press Menu to see more or less detail on the display.
4. **Stop Pinging:** When you are finished reviewing the operation, tap Ping Off from the MEGA Live status bar.

HELIX Series

1. Press and hold the VIEW key.
2. Select Sonar > MEGA Live View.
3. The sonar returns from the MEGA Live scan will begin to display on the MEGA Live View. Review the display for the following information and see the illustrations *Reviewing the MEGA Live View*.
 - **Bottom:** Confirm that the bottom is visible on-screen.
 - **Blocked Beams:** If the beams hit a hard surface, it will appear as bright white on the display. If the beams are blocked by any objects, move the objects if possible. You can also adjust the MEGA Live Range on the X-Press Menu to see more or less detail on the display.
4. **Stop Pinging:** When you are finished reviewing the operation, press the MENU key once. Select MEGA Live Pinging, and press the LEFT Cursor key.

Reviewing the MEGA Live View

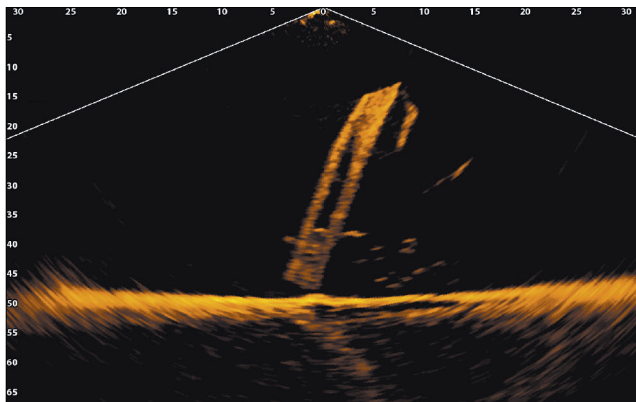

(Down)

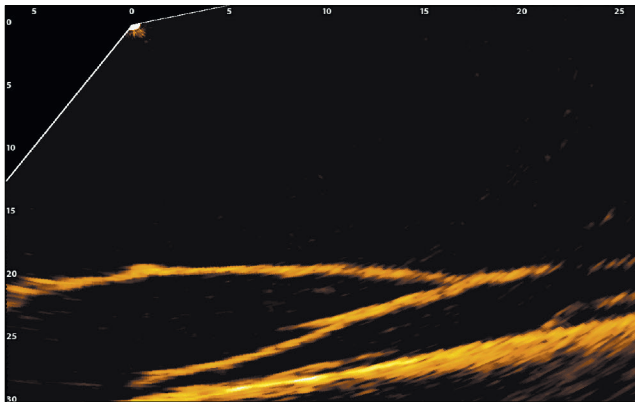

(Forward)

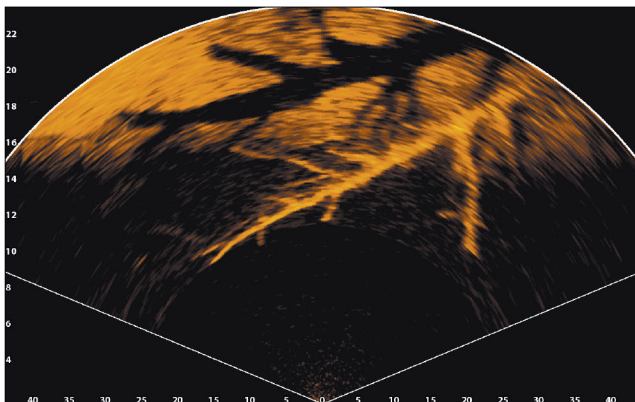

(Landscape)

Changing the MEGA Live Mode

Your control head will automatically select the best mode for your installation. Use the following instructions to manually change the MEGA Live Mode to Down, Forward, or Landscape.

APEX/SOLIX Series

1. With a MEGA Live Imaging View displayed on-screen, tap the MEGA Live Mode icon in the status bar.
2. Select Auto.
Tap the on/off button, or press the ENTER key, to turn Auto off.
3. Tap, or use the Joystick and Enter key, to select a MEGA Live Mode.

When you manually change the MEGA Live mode, a message box will display reminding you to also change the transducer's installation orientation. For instructions on changing the installation orientation, see Step 2 of *Install the Trolling Motor Mount, Section 5: Route the Cables and Connect Power*.

Changing the MEGA Live Mode (APEX/SOLIX)

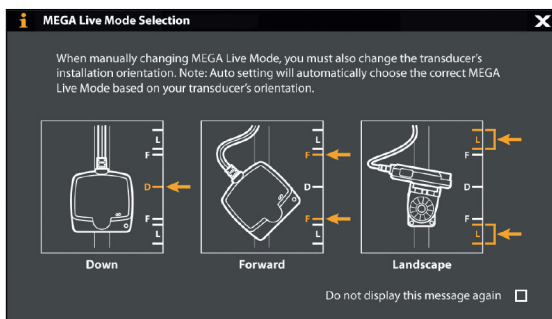

HELIX Series

1. **X-Press Menu:** With a MEGA Live Imaging View displayed on-screen, press the Menu key once.
2. Select MEGA Live Mode.
3. Press the RIGHT or LEFT Cursor keys to select a mode.

When you manually change the MEGA Live mode, a message box will display reminding you to also change the transducer's installation orientation. For instructions on changing the installation orientation, see Step 2 of *Install the Trolling Motor Mount, Section 5: Route the Cables and Connect Power.*

Changing the MEGA Live Mode (HELIX)

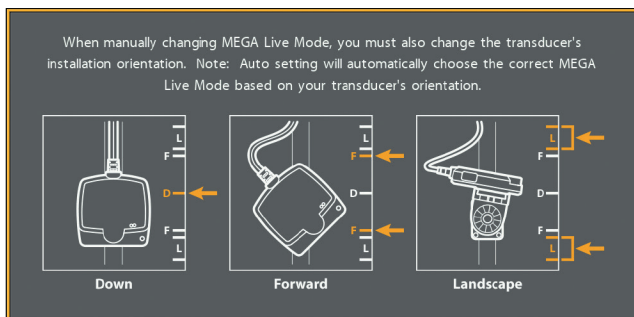

4. **Close:** Press the EXIT key.

4. Confirm the Heading Sensor Operation

It is important to confirm that the Heading Sensor is installed correctly by reviewing the heading digital readout.



NOTE: This procedure should be performed at slow speeds, in calm, open water, in a large area that is far from shallow water, boats, or other obstacles.

APEX/SOLIX Series

1. Press the HOME key.
2. Select Settings > General > Units > Compass > Magnetic North.
3. With a Chart View displayed on-screen, navigate the boat in a straight line, in calm, open water at 4.5 mph. Compare the Heading digital readout on the screen with the Course (COG) digital readout. The readouts should be within approximately 5° of each other.

Adjust: To adjust the zero point of the Heading Sensor, select Settings > Network NMEA 0183 > Data Offsets. Select Heading Adjustment. Tap the on/off button, or press the ENTER key, to turn it on. Press and hold the slider, or press and hold the ENTER key, to adjust the setting.

If the procedure failed: If the Heading digital readout is significantly different than the COG, the Heading Sensor might be installed in a location with too much magnetic interference. Check the installation location and possible magnetic disturbances in the area.

Confirming the Heading Digital Readout (APEX/SOLIX)

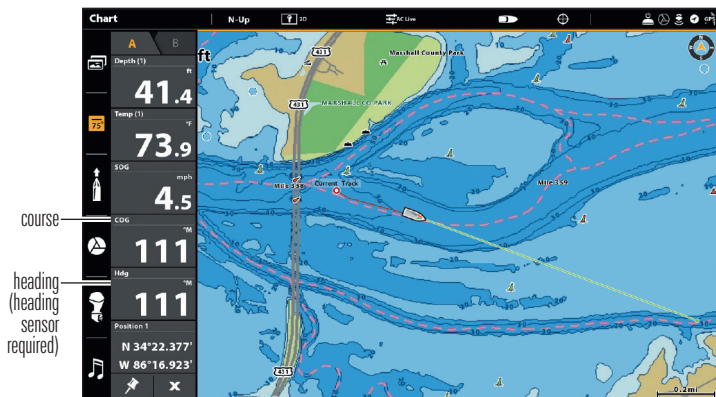

HELIX Series

1. **Main Menu:** Press the MENU key twice.
2. Select the Chart tab > North Reference > Magnetic.
3. Press the EXIT key.
4. Select the Setup tab > Select Readouts (G3N models) or Edit Data Boxes (G4N models).



NOTE: If the Select Readouts or Edit Data Boxes menu option does not appear under the Setup tab, change the User Mode to Custom. Select Main Menu > Setup tab > User Mode > Custom.

5. Select a Readout position or Data Box position and use the RIGHT or LEFT Cursor keys to select Vessel. Then select Heading. Select another Readout position or Data Box and select Course Over Ground.
6. Press the EXIT key until the Main Menu is closed.
7. Press and hold the VIEW key. Select Chart > Chart View.
8. Navigate the boat in a straight line, in calm, open water at 4.5 mph. Compare the Heading digital readout on the screen with the Course (COG) digital readout. The readouts should be within approximately 5° of each other.

Adjust (G3N): To adjust the zero point of the Heading Sensor, select Main Menu > Navigation tab > Heading Offset. Press the RIGHT or LEFT Cursor keys to adjust the setting.

Adjust (G4N): To adjust the zero point of the Heading Sensor, select Main Menu > Data Sources tab > Data Offsets> Heading Adjustment. Press the RIGHT or LEFT Cursor keys to adjust the setting.

If the procedure failed: If the Heading digital readout is significantly different than the COG, the Heading Sensor might be installed in a location with too much magnetic interference. Check the installation location and possible magnetic disturbances in the area.

Confirming the Heading Digital Readout (HELIX)

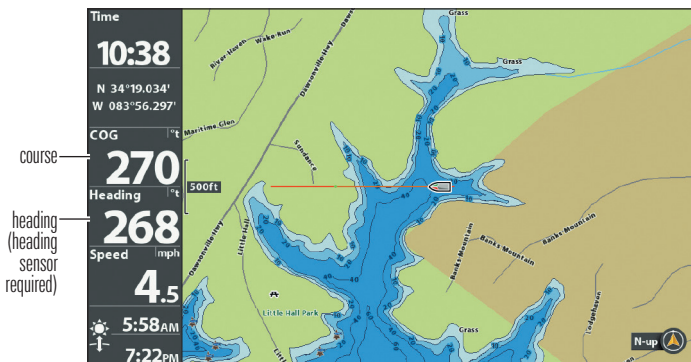

5. Confirm the Baud Rate *(for devices connected to the Sensor pigtail only)*

If there is an accessory, such as an autopilot, connected to the Sensor pigtail cable wires, you will need to confirm that the devices are communicating at the same baud rate. The baud rate details are as follows:

- **If the GPS Receiver/Heading Sensor is connected to the control head, and NMEA Output is turned on**, the control head will operate exclusively at a baud rate of 38400. If there is an accessory attached to the Sensor's pigtail, it also needs to operate at 38400. See your accessory installation guide to set the baud rate to 38400.
- **If NMEA Output is turned off**, then baud rates 4800, 9600, and 38400 are available on the control head and no further action is required.

Turn On/Off NMEA Output

APEX/SOLIX

1. Press the HOME key.
2. Select Settings > Network > NMEA 0183 > NMEA 0183 Output.
3. Tap the on/off button.

HELIX

1. **Main Menu:** Press the MENU key twice.
2. Select the Setup tab (G3N models) or the Data Sources tab (G4N models) > NMEA 0183 Output.
3. Press the RIGHT or LEFT Cursor keys to select On or Off. (Default = Off)



NOTE: The menu option in your Fishing System will be called NMEA 0183 Output or NMEA Output. If the menu option is not shown under the Setup or Data sources tab, make sure the User Mode is set to Custom (Setup tab > User Mode > Custom).

6. Set up the Network

After you have confirmed all connections, the MEGA Live Imaging transducer is ready to use on the water. Proceed to your ***MEGA Live Operations Manual*** to set up the temperature source and additional sonar sources.

Power Off

 **WARNING!** When the boat is stored or at dock, the MEGA Live Imaging transducer must be turned off to prevent draining the battery.

Power Off the Control Head

1. **APEX/SOLIX Series:** During operation, tap the top, right corner of the status bar or press the POWER key, and select Power Off.

HELIX Series: Press and hold the POWER key.

 **CAUTION!** Turning off the control head will NOT power off the MEGA Live Imaging transducer.

2. Turn off power on the main switch, breaker, or battery switch.

Powering off the MEGA Live Imaging transducer will be determined by the installation and power connection on your boat.

Travel with the MEGA Live Transducer Installed

The MEGA Live transducer must not hit the deck, base, or any objects. This is critical during transport. Check the tension of the trolling motor bracket after initial use and periodically thereafter to ensure that the installation remains stable.

Maintenance

Your Humminbird fishfinder is designed to provide years of trouble free operation with very little maintenance. Use the following procedures to ensure your Humminbird continues to deliver top performance.

Control Head Maintenance

It is important to consider the following precautions when using your Humminbird control head:

- **Chemicals**, such as those found in bug spray and sunscreen, may cause permanent damage to the control head screen. Such damage is not covered by the warranty.
- **NEVER leave the control head in a closed car or trunk.** The high temperatures generated in hot weather can damage the electronics.

Use the following information to keep the control head and screen clean.

- **Screen:** To clean the control head screen, use a mild soap (such as a nonabrasive liquid hand soap) and warm water. Wipe the screen dry with a soft cloth. Be careful to avoid scratching the screen. If water spots remain, use a solution of water and vinegar.



WARNING! Do not use a chemical glass cleaner on the screen. Chemicals in the solution may cause cracking in the lens of the unit.



NOTE: Do not wipe the screen while dirt or grease is on the screen.

- **Control Head:** If the control head comes into contact with salt spray, wipe the affected surfaces with a cloth dampened with fresh water.

Transducer Maintenance

Use the following information to maintain the transducer operation.

- If your boat remains in the water for long periods of time, algae and other marine growth can reduce the effectiveness of the transducer. Periodically clean the face of the transducer with a cloth dampened with fresh water.
- If your boat remains out of the water for a long period of time, it may take some time to wet the transducer when it is returned to the water. Small air bubbles can climb to the surface of the transducer and interfere with proper operation. These bubbles dissipate with time, or you can wipe the face of the transducer with your fingers after the transducer is in the water.

MEGA Live Imaging Maintenance

Use the following information to maintain the installation of the MEGA Live Imaging Transducer.

- Check the stability of the trolling motor mount after initial use and periodically thereafter to ensure that the installation remains stable.
- If your boat will be in long-term storage, remove the MEGA Live Imaging transducer and store it in -40°F to 158°F (-40°C to 70°C), dry conditions.

Troubleshooting

Before contacting the Humminbird Technical Support, please read the following section. Taking the time to review these troubleshooting guidelines may allow you to solve a performance problem yourself, and therefore avoid sending your unit back for repair.

"Out of the Water" Error Displays when MEGA Live Is in the Water

Use the following instructions if your fishing system is displaying an "Out of the Water" error message for your MEGA Live Imaging TargetLock when it is in the water.

Remove your MEGA Live Imaging transducer from the water. Place a wet piece of cloth over the two metal contacts on the surface of your transducer. If your transducer still does not work, contact Technical Support. If your transducer works with the rag, perform the following troubleshooting tasks:

1. Confirm that the drain/shield wire is connected to the boat's chassis ground terminal (see note).
2. Confirm that your MEGA Live is not connected to a trolling motor battery as this can create a problem with grounds. Ensure that your MEGA Live is connected to the starting battery or to the house batteries you use for your other electronics. Ensure that the trolling motor batteries are properly isolated from the rest of the boat's wiring.
3. If your MEGA Live is now working, there is likely a wiring issue. Check the wiring on the starting and house batteries, if present. If using a house battery system, ensure that it is grounded to the boat's chassis ground terminal (see note).
4. If you have an aluminum boat, ensure that there are no exposed wires touching the hull of the boat and that the boat's hull is properly grounded to the boat's chassis ground terminal (see note).
5. If all these steps have failed, contact Humminbird Technical Support.



NOTE: The boat's chassis ground terminal is where the boat's engine is grounded.

Fishing System Doesn't Power Up

If your Fishing System doesn't power up, use the installation guide that is included with your Fishing System to confirm specific details, making sure that:

- the power cable is properly connected to the Fishing System control head,
- the power cable is wired correctly, with red to positive battery terminal and black to negative terminal or ground, and the drain/shield wire to the boat's chassis ground terminal,
- the fuse is operational, and
- the battery voltage of the power connector is at least 12 Volts.

Correct any known problems, including removing corrosion from the battery terminals or wiring, or actually replacing the battery if necessary.

Fishing System Defaults to Simulator with a Transducer Attached

In addition to the MEGA Live Imaging accessory transducer, you will have a standard Humminbird transducer connected to the control head. A connected and functioning transducer with built-in temperature will cause the newly started Fishing System to go into Normal operating mode automatically. If, when you power up the Fishing System, it goes into Simulator mode automatically, even though a transducer is already connected, this means that the control head is not detecting the transducer. Perform the following troubleshooting tasks:

- Check the connections of all transducers that are connected to the control head or Ethernet network. See the transducer installation guide that was included with your Fishing System for connection information.
- Review this MEGA Live Imaging installation guide to confirm that the transducer cable is connected correctly to the Fishing System. Reconnect if necessary, and power on the Fishing System again to see if this fixes the problem.
- Replace the non-functioning transducer with a known good transducer if available and power up the control head again.
- Check the transducer cable. Replace the transducer if the cable is damaged or corroded.

Finding the Cause of Noise

Electrical noise usually affects the display with streaks or repetitive patterns on the view. One or more of the following sources can cause noise or interference:

Possible Source of Noise	Isolation
Other electronic devices	Turn off any nearby electronic devices to see if the problem goes away, then turn them on one at a time to see if the noise re-appears.
Other sonar devices	Turn off any nearby sonar devices to see if the problem goes away, then turn them on one at a time to see if the noise re-appears.
The boat's engine	To determine whether the boat's engine is the source of the noise, increase the RPMs while the boat is in neutral and stationary to see if the noise increases proportionately; if noise appears when you rev the engine, the problem could be the spark plugs, alternator, or tachometer wiring. Replace the spark plugs with resistor plugs, install an alternator filter, or route the control head power and transducer cables away from the engine wiring.

Specifications

Operating Frequency.....	1.05 CHIRP MHz
Power Requirement	10 to 12 VDC
Current Draw0.93 A maximum
Operating Temperature.....	32°F to 158°F (0°C to 70°C)
Storage Temperature	-40°F to 158°F (-40°C to 70°C)



NOTE: Humminbird verifies maximum stated depth in saltwater conditions, but actual depth performance may vary due to transducer installation, water type, thermal layers, bottom composition and slope.



NOTE: Product specifications and features are subject to change without notice.

ROHS STATEMENT: Product designed and intended as a fixed installation or part of a system in a vessel may be considered beyond the scope of Directive 2002/95/EC of the European Parliament and of the Council of 27 January 2003 on the restriction of the use of certain hazardous substances in electrical and electronic equipment.

ENVIRONMENTAL COMPLIANCE STATEMENT: It is the intention of Johnson Outdoors Marine Electronics, Inc. to be a responsible corporate citizen, operating in compliance with known and applicable environmental regulations, and a good neighbor in the communities where we make or sell our products.

WEEE DIRECTIVE: EU Directive 2002/96/EC “Waste of Electrical and Electronic Equipment Directive (WEEE)” impacts most distributors, sellers, and manufacturers of consumer electronics in the European Union. The WEEE Directive requires the producer of consumer electronics to take responsibility for the management of waste from their products to achieve environmentally responsible disposal during the product life cycle.

WEEE compliance may not be required in your location for electrical & electronic equipment (EEE), nor may it be required for EEE designed and intended as fixed or temporary installation in transportation vehicles such as automobiles, aircraft, and boats. In some European Union member states, these vehicles are considered outside of the scope of the Directive, and EEE for those applications can be considered excluded from the WEEE Directive requirement.



This symbol (WEEE wheelie bin) on product indicates the product must not be disposed of with other household refuse. It must be disposed of and collected for recycling and recovery of waste EEE. Johnson Outdoors Marine Electronics, Inc. will mark all EEE products in accordance with the WEEE Directive. It is our goal to comply in the collection, treatment, recovery, and environmentally sound disposal

of those products; however, these requirements do vary within European Union member states. For more information about where you should dispose of your waste equipment for recycling and recovery and/or your European Union member state requirements, please contact your dealer or distributor from which your product was purchased.

Contact Humminbird

Contact Humminbird Technical Support through our Help Center at <https://humminbird-help.johnsonoutdoors.com/hc/en-us> or by writing to the address below:

Humminbird Service Department
678 Humminbird Lane
Eufaula AL 36027 USA

Social Media Resources:



Facebook.com/HumminbirdElectronics



Twitter.com (@humminbirdfish)



Instagram.com/humminbirdfishing



YouTube.com/humminbirdtv



 **HUMMINBIRD**®