

Item	Part #	Description	Qty.
1	2374151	CONTROL BRD ASM, TALON 3 (SUB)	1
2	2040340	CONNECTOR, SCOTCHLOK, UY2 (2 ASSEMBLED)	7
3	2378705	BRACKET-SENSOR TALON 3 (ASSEMBLED)	1
4	2373439	SCREW-#4-40 X 5/16" PPH SS (ASSEMBLED)	2
5	2373106	NUT-#4-40 NYLON HEX SS (ASSEMBLED)	2
6	2298800	LOOM-WIRE, 1/4 X 4" (ASSEMBLED)	1
7	2305404	SHRINK TUBE-.374 ID X 1.0"	4
8	2305402	SHRINK TUBE-.374 OD X 2.25"	1
9	2303434	SCREW #8-32 X 5/8 MACH PHCR SS	3
10	2263434	SCREW #8-18 X 1" PPH S/S	2
11	2371780	SPACER,.166 ID, 1/4 OD, .188,ALM	2
12	2373485	SCREW-#6-32X1/4"PPH TYPE F	2

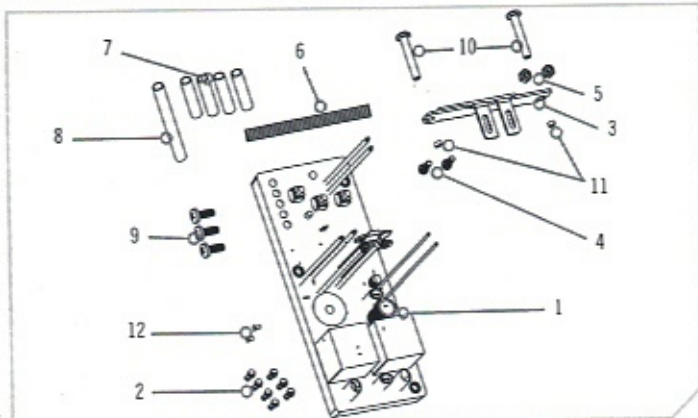

### TOOLS AND RESOURCES REQUIRED

- #2 Phillips Screwdriver
- #1 Phillips Screwdriver
- Heat Gun
- Utility Knife
- Pliers
- Approximately 30 Minutes

## **⚠ CAUTION**

Always wear safety glasses and gloves. Disconnect all power to the Talon before beginning any work or maintenance. Johnson Outdoors Inc. is not responsible for any damage due to improper rigging or installation. If you do not have the skills, experience and tools to perform the following maintenance and repairs we recommend you seek the help of a Minn Kota Authorized Service Provider.

A list of Authorized Service Providers can be found at <https://www.minnkotamotors.com/Authorized-Service-Providers/>. Or contact our Technical Service Department by email at [service@minnkotamotors.com](mailto:service@minnkotamotors.com) or by dialing 800-227-6433

### INSTALLATION

**1** Place the Control Board on the Talon Main Extrusion and use the (3) 2303434 #8-32 Machine Screws to Secure the Board to the Control Board Spacers installed in the Main Extrusion.

- 2** Connect the Wires according to the Wiring Diagram:
- Place (2) of the 2305404 Heat Shrinks on the Black and White Power Lead Wires and connect the wires to the Board Terminals as indicated on the included wiring diagram.
  - Place the 2305402 Heat Shrink on the Green Power Lead Wire, Connect the Green Power Lead Wire to the Green Lead coming from the Control Board.
  - Place (2) of the 2305404 Heat Shrinks on the Red and Black Motor Wires and connect the Motor Wires to the Board Terminals as indicated on the included wiring diagram.
  - Use (2) of the 2040340 Scotchlok Connectors to connect the two Yellow Wires coming from the end of the Motor the two Yellow Wires coming from the Control Board.

*Continued On Next Page*

**NOTICE:** The Brake Connection is critical to operation, make sure both wires are fully inserted prior to squeezing the connector closed, verify the connector is fully compressed.



## 2

Continued From Previous Page.

- e. Route the Upper Sensor Assembly (Bracket, Wire Loom, Sensor and Wires) from the Control Board to the upper end of the Main Extrusion. The wires should pass through the space between the Channel Divider and the front of the Talon (away from the Cables). Use the (2) 2263434 #8-18 Screws to secure the Upper Sensor Bracket and the (2) 2371780 Spacers to the upper end of the Main Extrusion. Installed correctly the Spacers are between the Sensor Bracket and the Main Extrusion.
- f. Install the Wrap Drum Hub Sensor. This Sensor is installed on the Wrap Drum Mount between the Motor Assembly and the Wrap Drum Mount. It is necessary to remove the Motor Assembly from the Wrap Drum Mount to remove the old sensor and install the new one. The Wrap Drum Hub Sensor installs on the motor side the Wrap Drum Mount using the (2) 2373485 #6-32 Screws. The raised part of the sensor is positioned into the rectangular opening in the Wrap Drum Mount so the writing on the sensor is towards the Wrap Drum Hub.
- g. Verify the wires for the Worklight are routed from the Worklight Assembly to the Control Board inside the Main Extrusion between the Channel Divider and the front of the Talon (away from the Cables). Use the remaining (3) 2040340 Scotchlok Connectors to connect the Red, White and Blue Wires coming from the Worklight Assembly to the Red, White, and Blue Wires that come from the Control Board.
- h. Slide the (4) 2305404 Heat Shrinks into position so they cover the sleeves that surround the Control Board Terminals, place the 2305402 Heat Shrink so it completely covers the connection made by the Male and Female Terminals on the Green Wire, then use a Heat Gun to shrink and seal all of the wire connections.

## 3

Complete assembly of the Talon so it is safe to extend the Talon its full Length.

## 4

Program the Control Board for Talon Length; this step is necessary on 10, 12 and 15 foot models, 8 foot models do not require programming:

- a. Connect the Black (B-) and White (B+) Power Leads to a 12v Power Supply.
- b. Verify it is retracted by pressing the Up Button on the Control Panel.
- c. Connect the Green Wire to the (B+) of the 12v Power Supply, within 1 second of making this connection press and release the Down Button on the Control Panel. The Talon will begin beeping.
- d. Before the beep sequence stops: Disconnect the Green Wire from the (B+) of the 12v Power Supply, then Press and Release the Down Button on the Control Panel. The Talon will extend to its full length then automatically retract.
- e. To test for proper function extend the Talon and observe the lights to verify that the 5<sup>th</sup> light comes on just prior to Talon full extension.



### CAUTION

The Talon will Fully Extend and Retract during this step. Prior to step 4c verify the Talon is fully supported and that it is safe for it to fully extend and retract.

**NOTICE:** A drop in voltage during the programming process can prevent full completion. If the process does not progress as described observe the voltage at the white and black leads entering the control board during as the Talon is extended; the voltage should not drop below 10.5v.

*This Completes Control Board Installation*

**WIRING DIAGRAM**

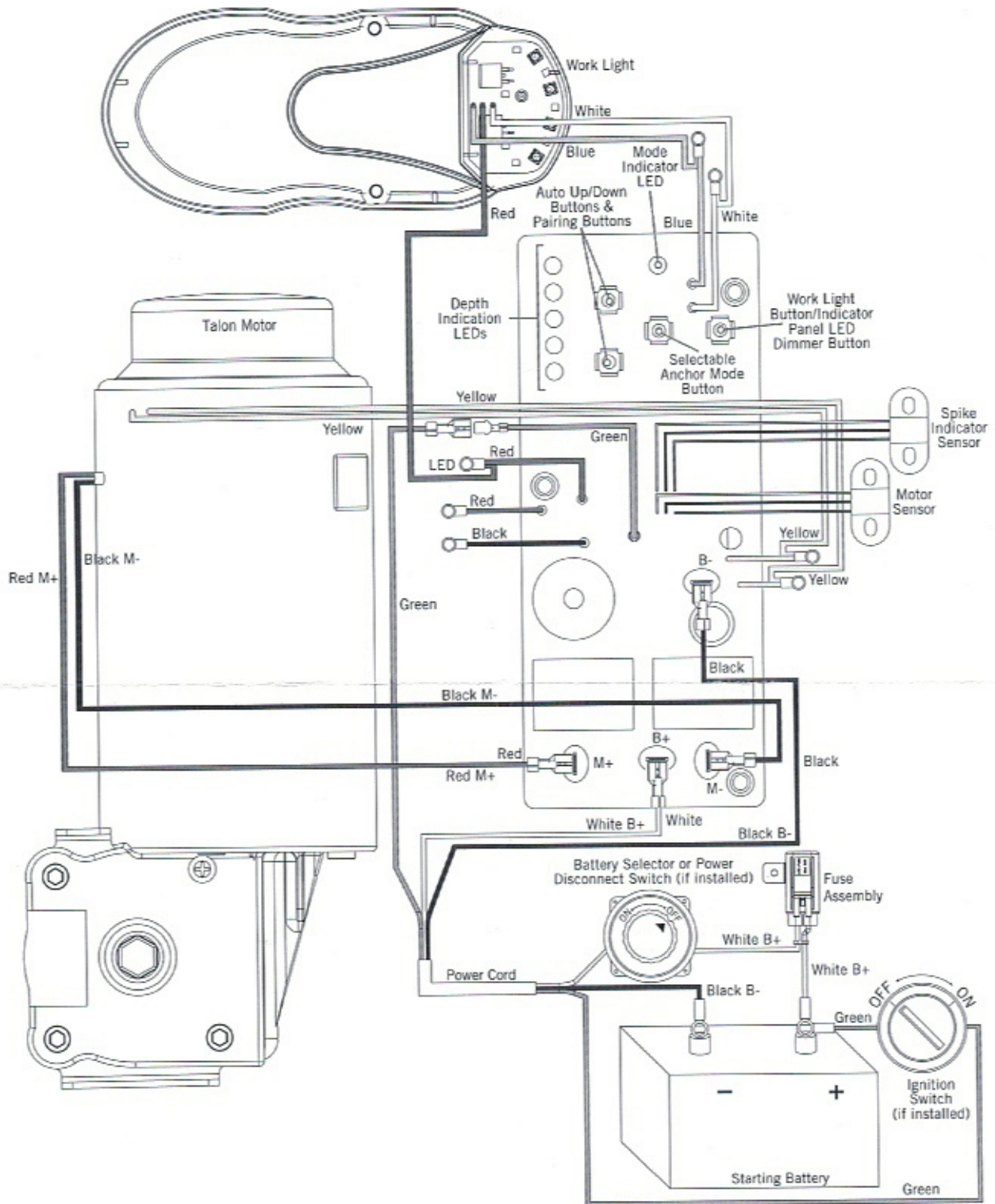

minnkotamotors.com

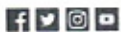

Part #2384950

Minn Kota Consumer & Technical Service  
 Johnson Outdoors Marine Electronics, Inc.  
 PO Box 8129  
 Mankato, MN 56001

ECN 39334

121 Power Drive  
 Mankato, MN 56001  
 Phone (800) 227-6433  
 Fax (800) 527-4464



©2019 Johnson Outdoors Marine Electronics, Inc.  
 All rights reserved.

Rev C

02/19