



Depend on Davey

**DAVEY**

### APPLICATIONS

Ideal for swimming pool applications such as:

- Lap pools
- Concrete and tile pools
- Fibreglass pools
- Swim Jet installation
- Sport or rehabilitation installations

### WHY CHOOSE THE Davey Hurricane Turbo Swim Jet System?

- Maximises the value and enjoyment of your pool
- High powered pump provides a high flow jet of water to swim against
- Swim jet controlled by air switch on swim jet. No need to leave the pool to turn on or off
- Turbo swim jet outlet provides 3 settings for jet flow control
- Simple installation of swim jet – only one hole required for both suction and return points
- Designed for dependability and long life using corrosion resistant, UV stabilised materials
- Self priming up to 4 metres for easy operation and installation
- Stainless steel pump shaft suited for salt chlorinated pools
- 65mm barrel unions for easy installation to large OD pipe
- 65-80mm PVC adaptors also available for easy connection to DN80 pipe – M3689
- 2 Year guarantee



DAVEY

**Hurricane®**

**Turbo Pump & Swim Jet System**

Has the power to turn your swimming pool into a practical sport and leisure zone, with a counter-current swim system.

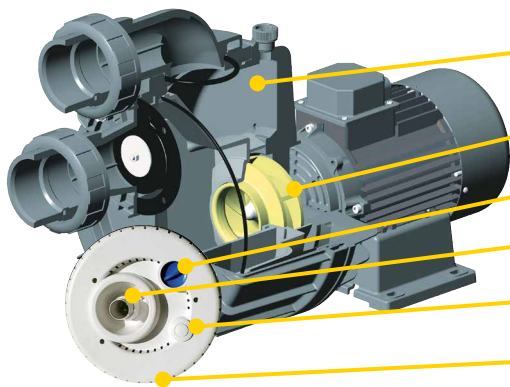

- Corrosion resistant body, foot and diffuser from glass-filled polypropylene construction.
- Stainless steel motor shaft for corrosion resistance in salt water pools. Carbon / Ceramic mechanical seal.
- Air Mixture Dial regulates jet bubbles through outlet adjustment.
- Adjustable jet stream nozzle.
- Air switch to activate pump from pool.
- Integrated suction and return-jet.

ELECTRICAL DATA	
<b>Model</b>	<b>Hurricane 300</b>
Voltage (V)	220-250
Supply Frequency/Phase	50Hz / 1
Run Current (A)	12.5
Motor Input Power (W)	3000
Motor Output Power (W)	2300
RPM	2900
Enclosure Class (IP)	55
Insulation Class	F
Approval No.	W2442

OPERATING LIMITS	
Maximum water temperature	35°C
Maximum ambient temperature	50°C

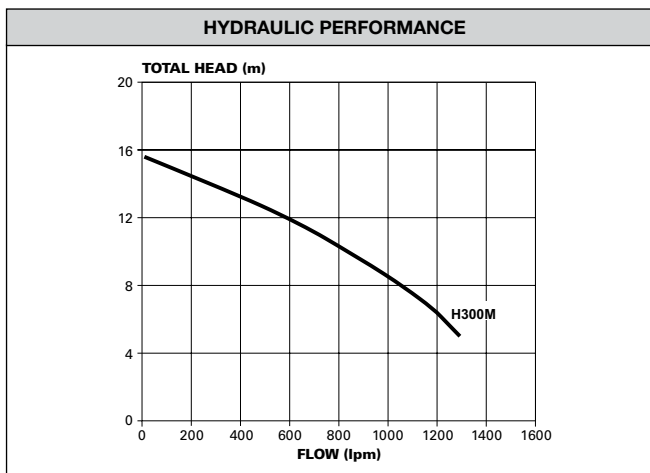

DIMENSIONS (mm)								Net Weight (Kg)
Type	A	B	C	D	E	F	G	
<b>H300M</b>	615	335	414.6	195	247	130	65	26

