

±100-165 (4-6")

approx 15.5kg (34lb)

- PENDANTS: nine
- MOUNTING: 142mm (5.6") x 35mm (1.38")
- LAMPING: 1.5w LED
- STEM LENGTH: 2.7m (9') long stem
- ADDITIONAL EXTENDERS: 153mm (6") / 305mm (12") / 914mm (36") / 1524mm (60")
- MATERIALS: blown and dipped grey or white opaline glass, electrical components, brass, black, or white canopy
- WEIGHT: approximately 15.5kg (34lb)
- POWER SUPPLIES: integral

DESCRIPTION

The stem suspended system comes in a brass, black, or white finish with a 142mm (5.6") diameter mounting plate rated for ceiling use.

57 is an exploration of a technique used for producing closed cell foam. The process involves trapping voids of air of different sizes and configurations within a glass matrix, yielding a shape loosely referencing a rain cloud. These pockets of air remain invisible when the piece is off, but come alive to reveal an interior universe when the piece is illuminated. By virtue of the fabrication process, each piece is completely unique.

NOTES

- + Purchase replacement lamps online at www.bocci.com/shop/bulbs
- + Power supply can be remote mounted with 94mm (3.7") x 6mm (0.24") canopy.
- + **The brass used in our Stem Series is untreated and, as such, will develop a natural patina over time. To avoid any marking or tarnish on the brass during handling and installation, please use the gloves provided in your shipment.**

US Patent # D796732
EU Design Patent # 002268581-0001 to 0006

Made in Vancouver, Canada

Vancouver
sales@bocci.com
www.bocci.com

Berlin
europe@bocci.com
www.bocci.com

STEM - SUSPENDED

57.9

Design by Omer Arbel
PRODUCT SPECIFICATION

© 2020, Bocci Design and Manufacturing Inc. All rights reserved. Any inquiries should be directed to: info@bocci.com

BOCCI



1

Thread the cover cap on one end of the stem.

Note: Bocci recommends wearing thin gloves during installation to protect the stem finish and the glass surface.



2

Connect the stem pieces by threading the stem connector to the stems.

Note: This step is only necessary for overall stem lengths longer than 1.8m (6').

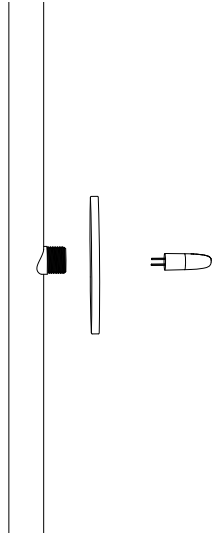

3

Thread the pendant mounting plate onto the stem.

Carefully insert provided lamp into socket.

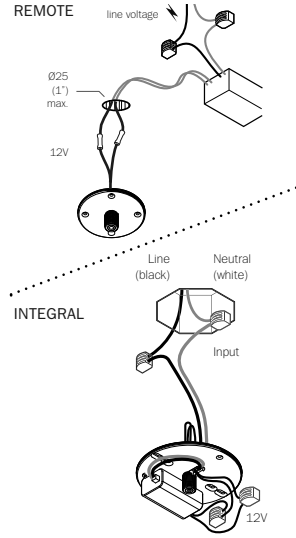

4

Connect power supply to line voltage.

- i. Connect input low voltage wire to 12V DC output wires by feeding the wires through the slots on the mounting plate.
- ii. Connect the black wire to line wire and white wire to neutral wire.
- iii. Ensure that line voltage is not active during this part of the installation!

Note: As an option, Bocci recommends mounting power supplies remotely in a close, accessible and hidden location for ease of long term maintenance. Installation to be done by certified personnel to ensure compliance with the code.

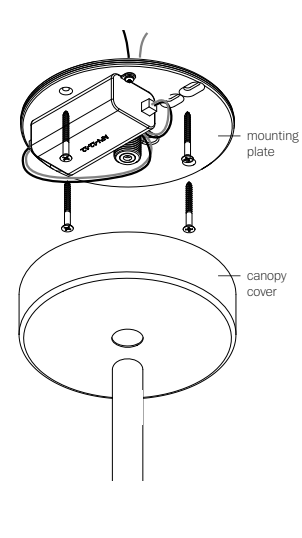

5

The client is responsible to ensure fasteners are attached to a robust structural substrate.

Affix mounting plate to surface with fasteners provided.

Thread canopy cover onto the mounting plate.

Thread on the stem to canopy.

Turn power to fixture on.

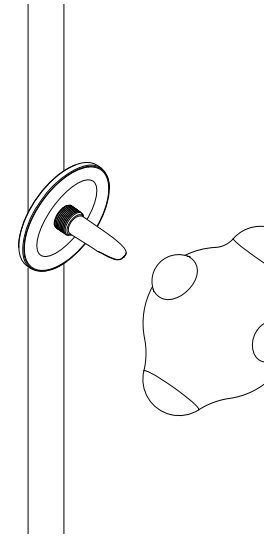

6

Gently thread pendant onto the stem. Be sure to carefully place the pendant so as not to damage the lamp during installation.

Clean fingerprints from fixture surfaces.

For additional assistance, please contact Bocci:

Vancouver
sales@bocci.com
www.bocci.com

Berlin
europe@bocci.com
www.bocci.com

US Patent # D796732
EU Design Patent # 002268581-0001 to 0006

Made in Vancouver, Canada

STEM - SUSPENDED

57.9

Design by Omer Arbel
PRODUCT INSTALLATION INSTRUCTIONS

© 2020, Bocci Design and Manufacturing Inc. All rights reserved. Any inquiries should be directed to: info@bocci.com

BOCCI