

±165 (6.5")

approx 15kg (33lb)

- PENDANTS: twelve
- MOUNTING: 94mm (3.7") x 6mm (0.24")
- LAMPING: 1.5w LED
- STEM LENGTH 3.7m (12') long stem
- ADDITIONAL EXTENDERS 153mm (6") / 305mm (12") / 914mm (36") / 1524mm (60')
- MATERIALS: blown glass, electrical components, unlacquered brass or matte black brass stem, black or white canopy
- WEIGHT: approximately 15kg (33lb)
- POWER SUPPLIES: remote mounted

DESCRIPTION

The stem ceiling mounted system comes in unlacquered brass or matte black stem with a 94mm (3.7") diameter mounting plate rated for ceiling use.

Individual 28s result from a complex glass blowing technique whereby air pressure is intermittently introduced into and then removed from a glass matrix which is intermittently heated and then rapidly cooled. The result is a distorted spherical shape with a composed collection of imploded inner shapes, one of which acts as a shade for the light source.

Standard 28s are made with clear glass exterior spheres and milk white interior lamp holder cavities. 28s are possible with infinite versatility in colour compositions, sizes and shapes.

NOTES

- + Purchase replacement lamps online at www.bocci.com/shop/bulbs
- + **The brass used in our Stem Series is untreated and, as such, will develop a natural patina over time. To avoid any marking or tarnish on the brass during handling and installation, please use the gloves provided in your shipment.**

US Patent # D687,740
EU Patent # 001695834-001 to 004

Made in Vancouver, Canada

Vancouver
sales@bocci.com
www.bocci.com

Berlin
europe@bocci.com
www.bocci.com

STEM - CEILING MOUNTED

28.12

PRODUCT SPECIFICATION



1

Thread the cover cap on one end of the stem.

Note: Bocci recommends wearing thin gloves during installation to protect the stem finish and the glass surface.



2

Connect the stem pieces by threading the stem connector to the stems.

Note: This step is only necessary for overall stem lengths longer than 1.8m (6').

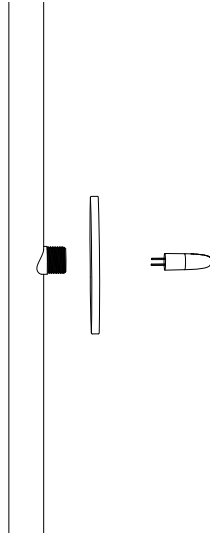

3

Thread the pendant mounting plate onto the stem.

Carefully insert provided lamp into socket.

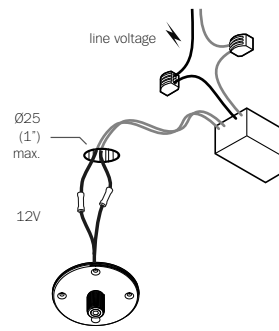

4

Connect power supply to line voltage.

- i. Connect input low voltage wire to 12V DC output wires.
- ii. Connect the black wire to line wire and white wire to neutral wire.
- iii. Ensure that line voltage is not active during this part of the installation!

Note: Mount power supplies remotely in a close, accessible and hidden location for ease of long term maintenance. Installation to be done by certified personnel to ensure compliance with the code.

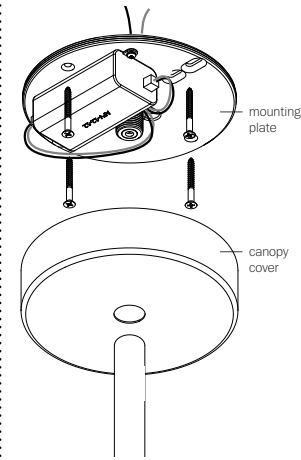

5

The client is responsible to ensure fasteners are attached to a robust structural substrate.

Affix mounting plate to surface with fasteners provided.

Thread canopy cover onto the mounting plate.

Thread on the stem to canopy.

Turn power to fixture on.

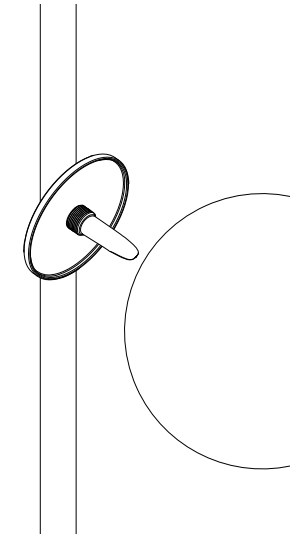

6

Gently thread pendant onto the stem. Be sure to carefully place the pendant so as not to damage the lamp during installation.

Clean fingerprints from fixture surfaces.

For additional assistance, please contact Bocci:

Vancouver
sales@bocci.com
www.bocci.com

Berlin
europe@bocci.com
www.bocci.com

US Patent # D687,740
EU Patent # 001695834-001 to 004

Made in Vancouver, Canada

STEM - CEILING MOUNTED

28.12

PRODUCT INSTALLATION INSTRUCTIONS

© 2021, Bocci Design and Manufacturing Inc. All rights reserved. Any inquiries should be directed to: info@bocci.com

BOCCI