

# Solar USB Charger 2.0

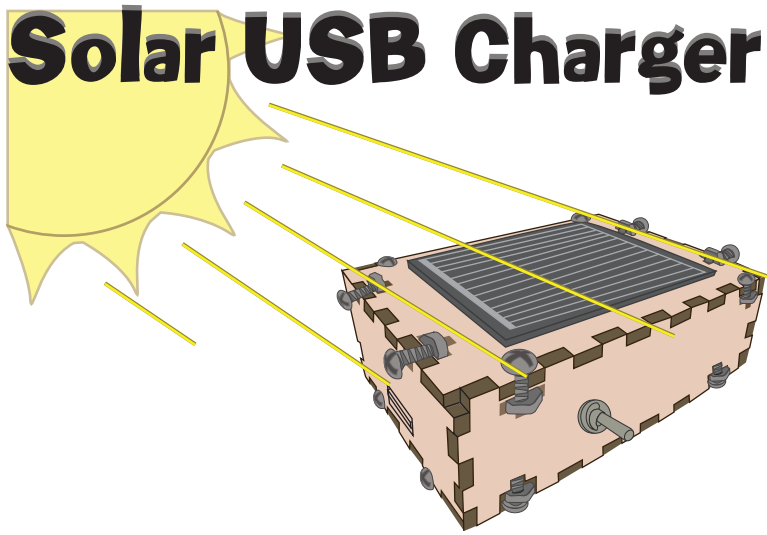

**TIME:**  
30-60 MINUTES

## YOU WILL NEED:

### PARTS:

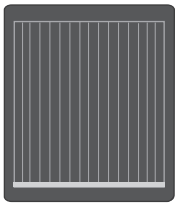

6V Solar Cell

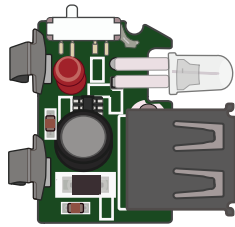

USB Charging Circuit

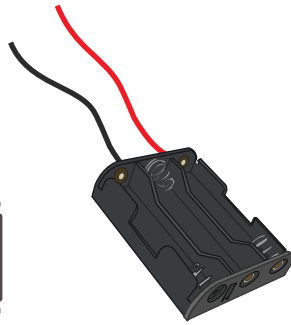

AA 3 Battery Holder



AA Rechargeable Batteries

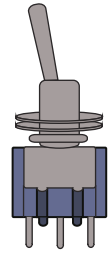

Toggle Switch

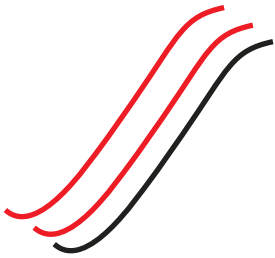

Wire

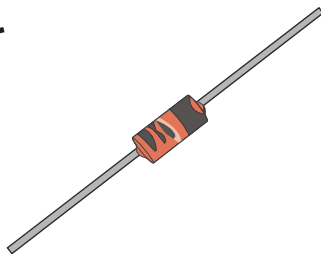

1N914 Diode

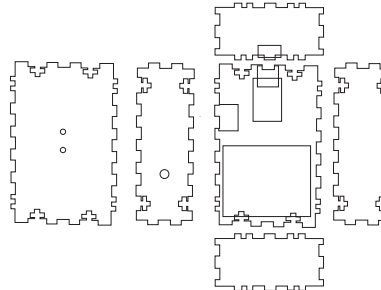

Wooden Case

### TOOLS:

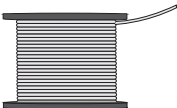

Solder

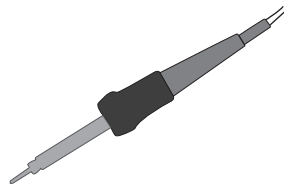

Soldering Iron

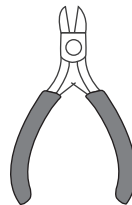

Wire Cutters

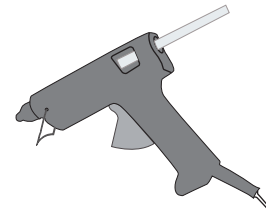

Hot Glue Gun or Foam Tape (optional)



Make sure to warm up your Soldering Iron and Glue Gun before you start.

Please visit [www.BrownDogGadgets.com](http://www.BrownDogGadgets.com) for more great ideas & info.

## 1 STRIP WIRES

Strip the ends of the loose black and red wires, including the ones on the battery holder.

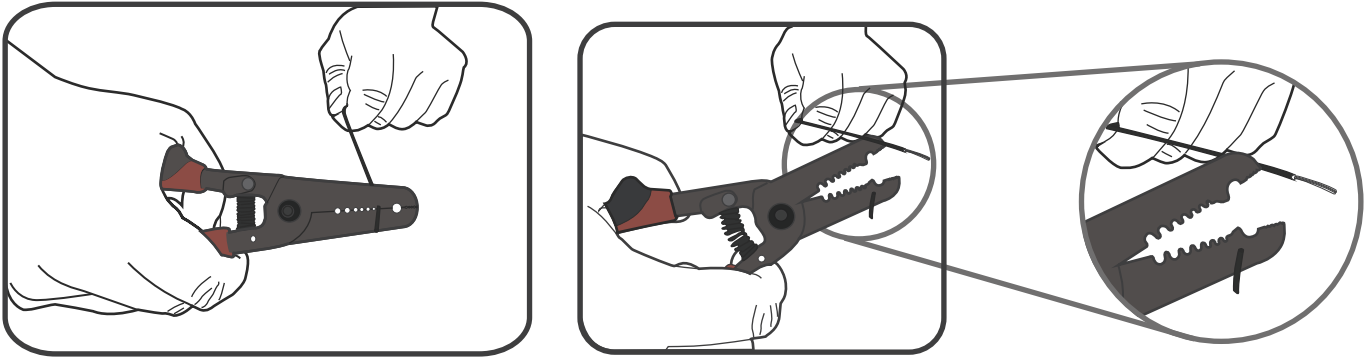

## 2 SOLDER the DIODE

Look at your diode. Find the black stripe. This is the negative end. Solder the wire on the positive (orange) side of your diode to the positive (+) terminal of your solar cell. Cut off the excess wire on the positive (orange) side of the diode.

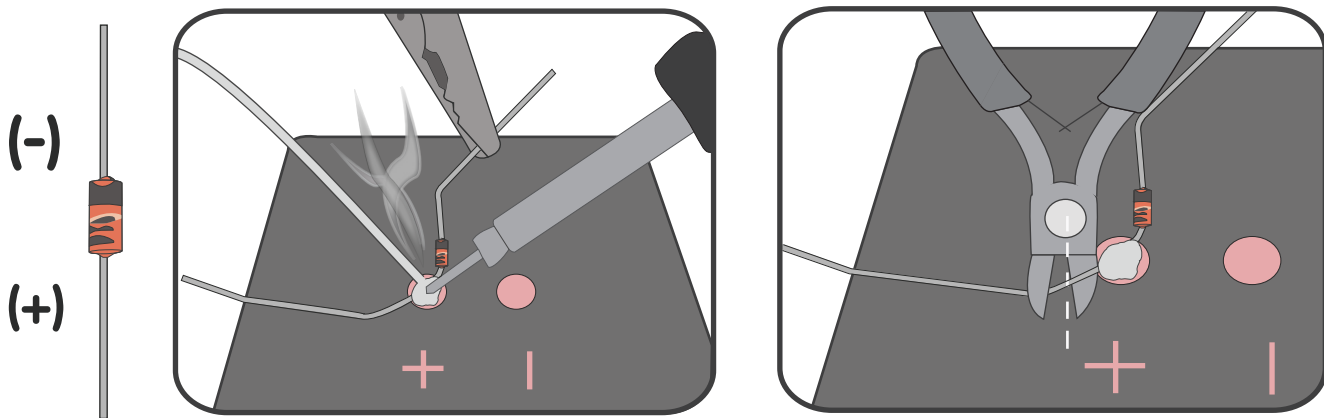

## 3 SOLDER LOOSE RED WIRE

Twist one end of the first loose red wire around the negative (black stripe) side of your diode. Solder them together. Put the other end of the wire through the hole in the top piece of the box.

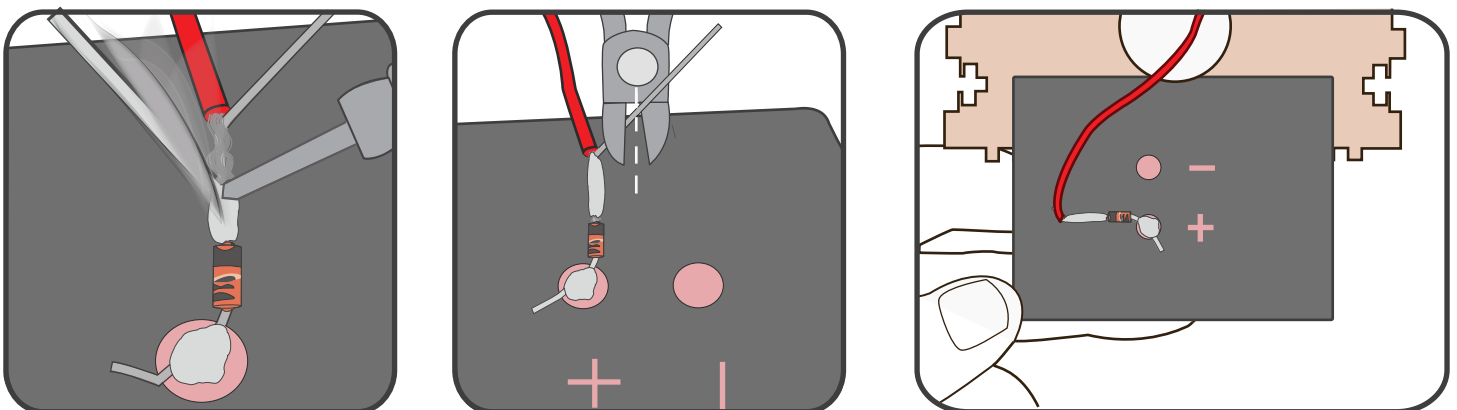

#### 4 **TWIST BOTH RED WIRES**

Twist the other end of the first loose red wire with the positive (red) wire from the battery pack.

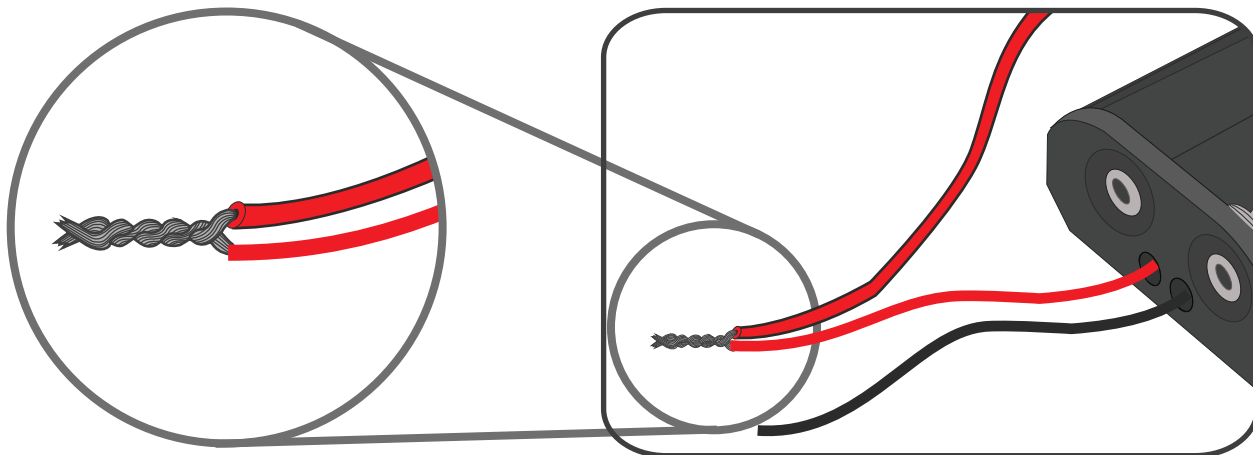

#### 5 **SOLDER RED WIRES to SWITCH**

Solder these wires to the center terminal of the Switch. Solder the second loose red wire to the outside legs of the toggle switch.

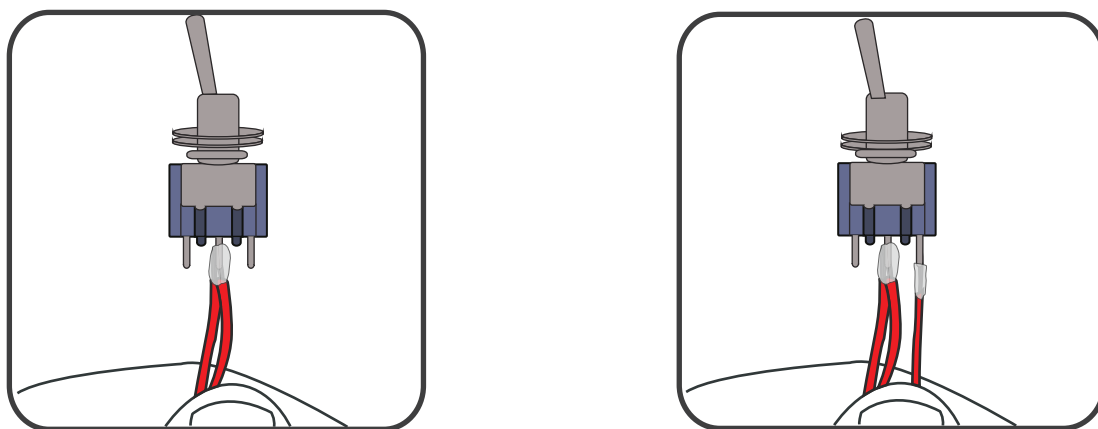

#### 6 **SOLDER RED WIRE to USB CIRCUIT**

Solder the other side of the second red wire to the positive (+) terminal of the USB circuit.

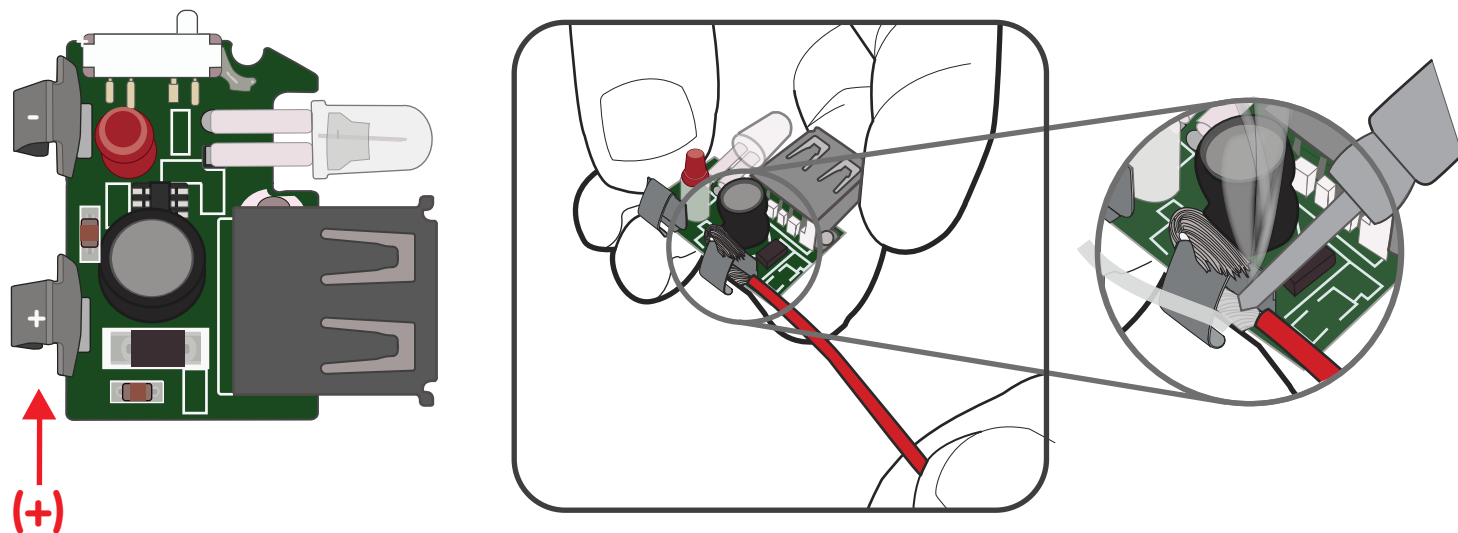

## 7 SOLDER LOOSE BLACK WIRE

Solder one end of the loose black wire to the negative (-) terminal of your solar cell.

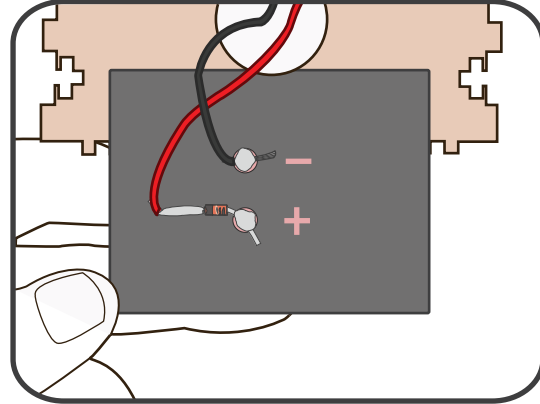
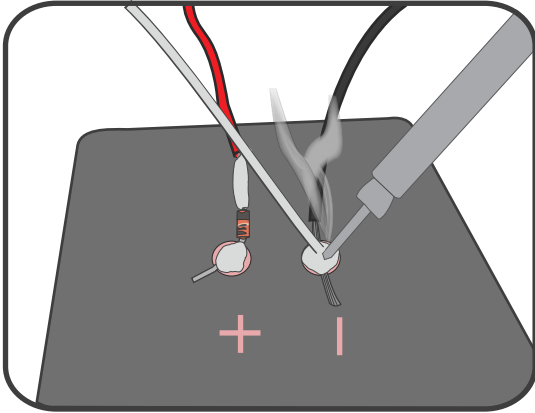

## 8 TWIST BLACK WIRES

Twist the negative (black) solar cell wire and the negative (black) battery holder wire together.

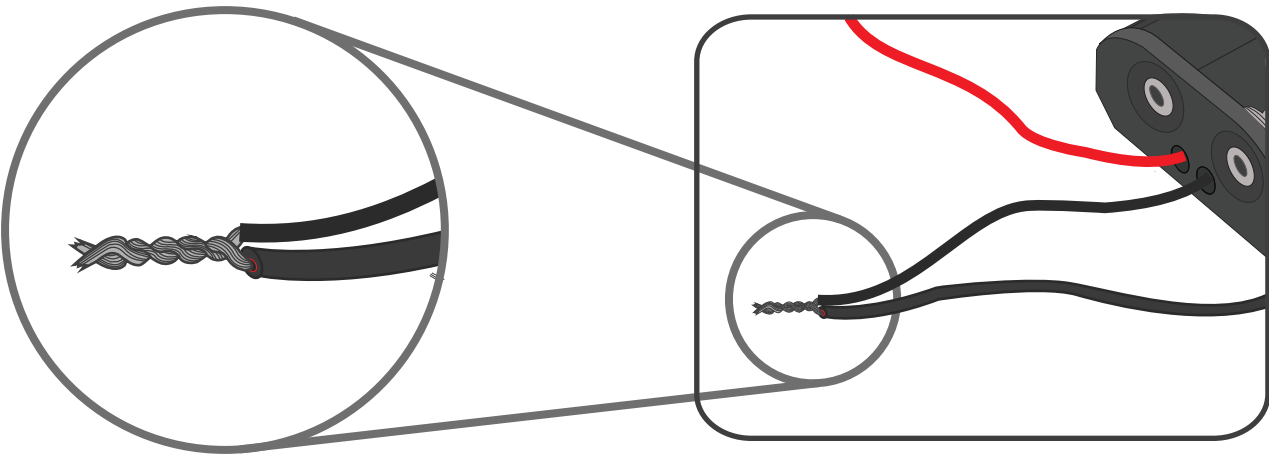

## 9 SOLDER BLACK WIRES to USB CIRCUIT

Solder the other side of the loose black wires to the negative (-) terminal of the USB circuit.

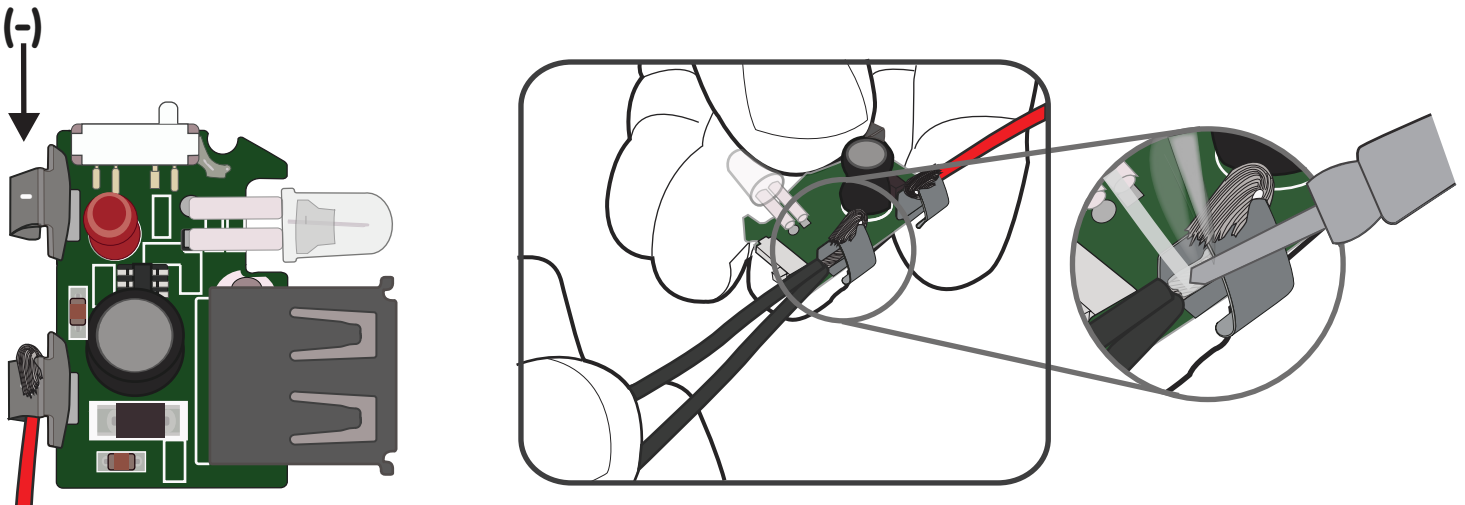

## 10 **FLIP the SWITCH**

Push the switch on the USB circuit all the way back (toward the soldered terminals)

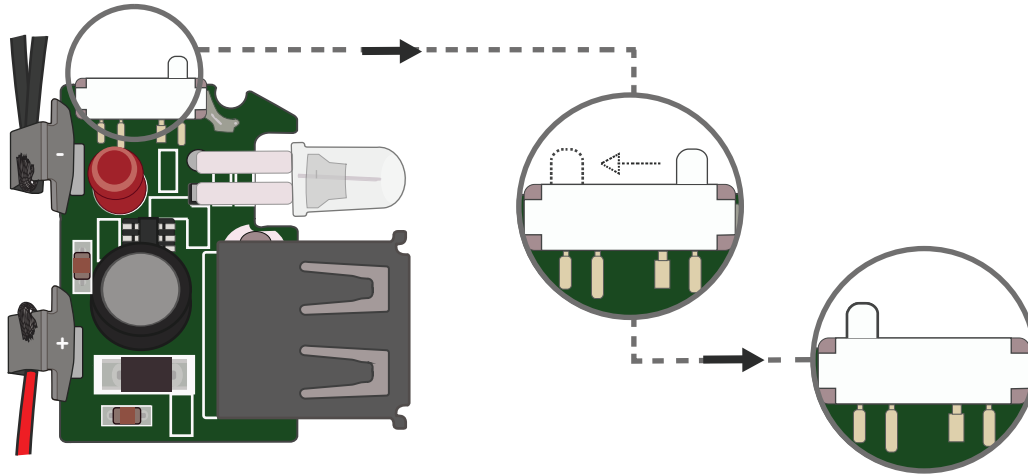

## 11 **CUT LEDs**

Use wire snips to cut off the two LEDs on the USB Circuit

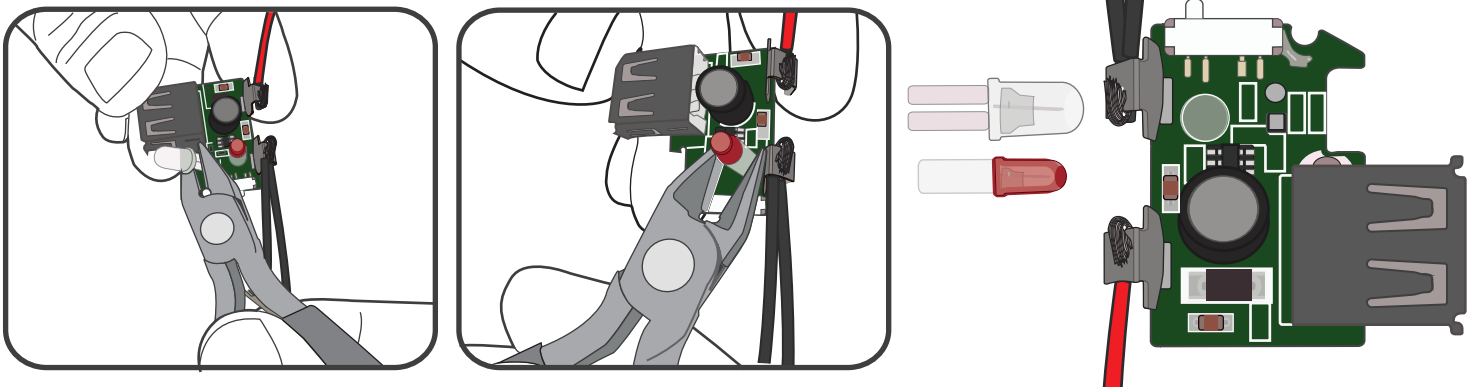

## 12 **TEST CIRCUIT**

Use a gadget to test your circuit)before final assembly. Check the troubleshooting sections on the last page if it is not working.

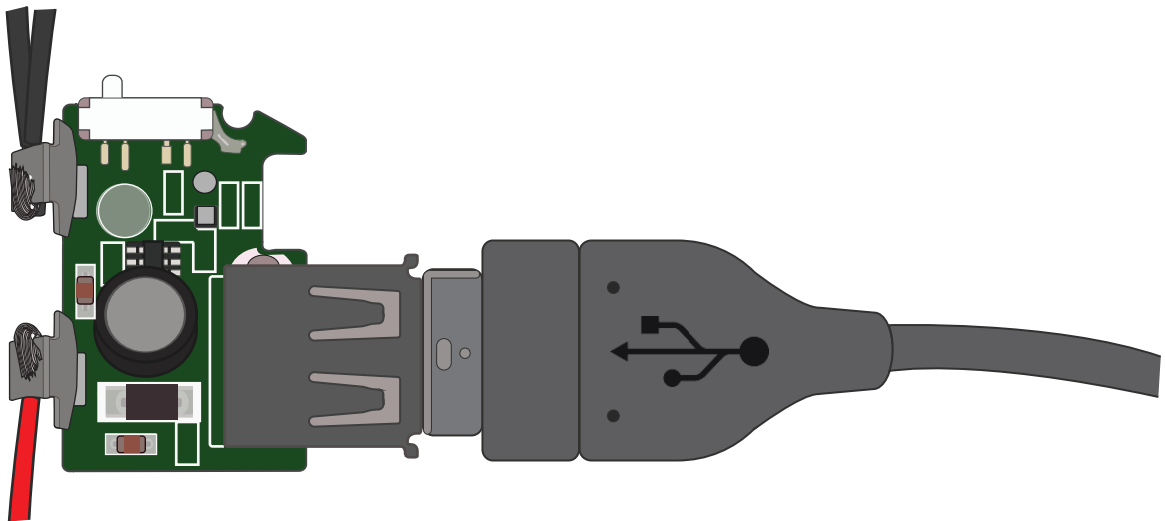

Please visit [www.BrownDogGadgets.com](http://www.BrownDogGadgets.com) for more great ideas & info.

## 12 FINAL ASSEMBLY

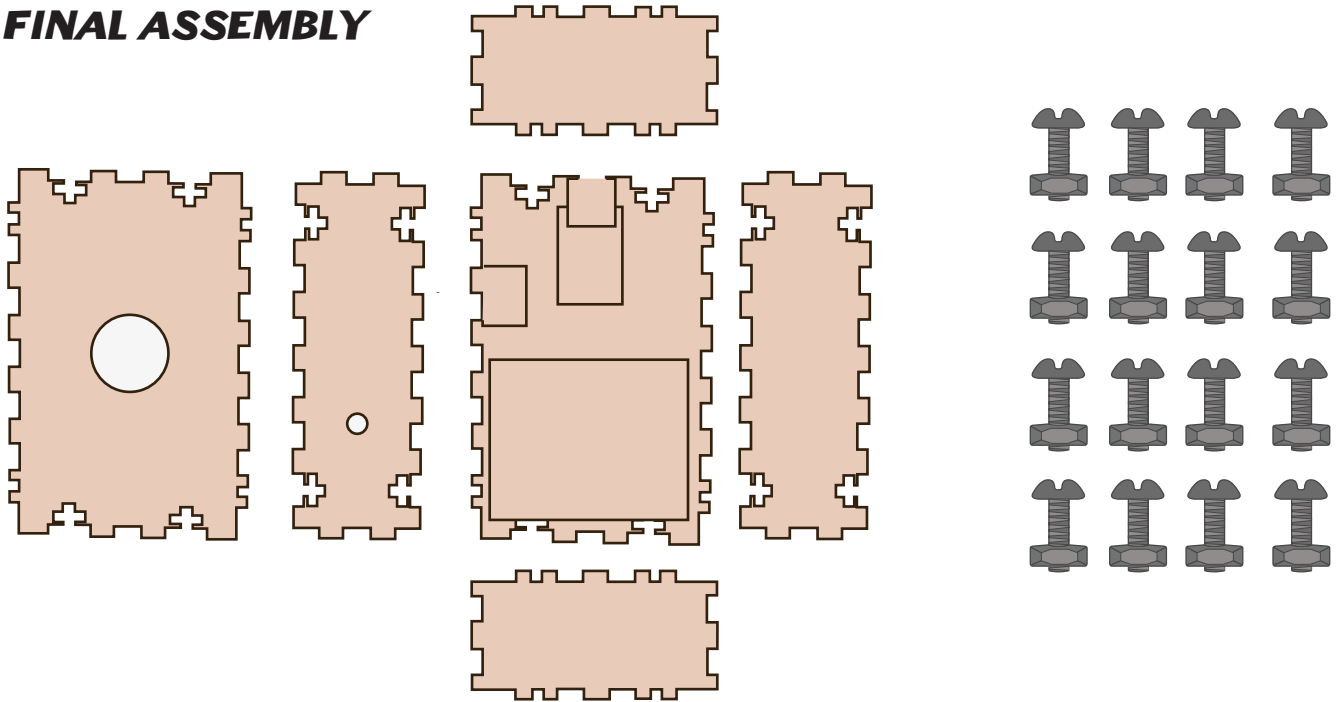

**A** Assemble sides and bottom of box.

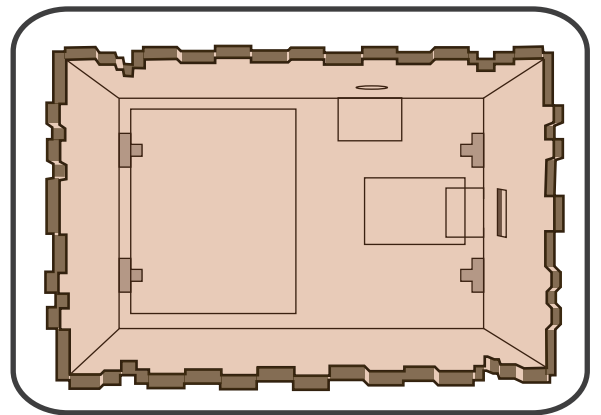
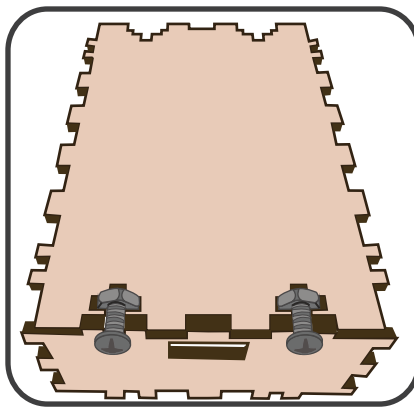
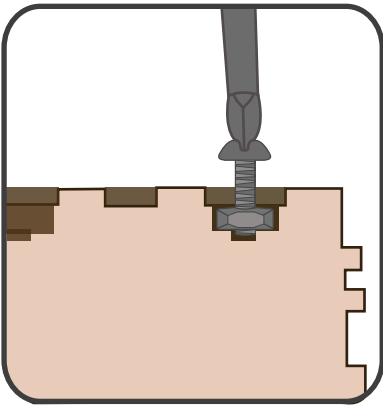

**B.** Use hot glue or foam tape to secure battery holder & USB circuit. Secure switch with the included nut.

**C.** Use hot glue or foam tape to secure solar panel to the top of the box and screw it down.

**B**

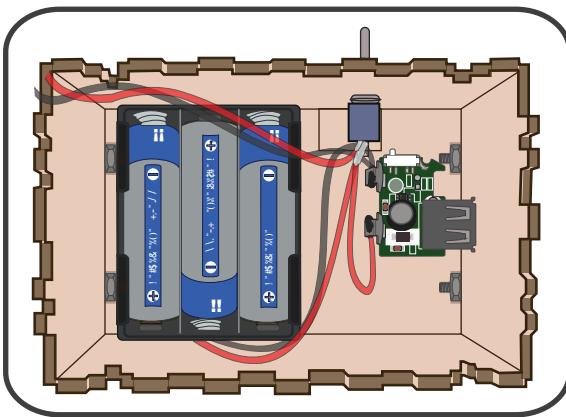

**C**

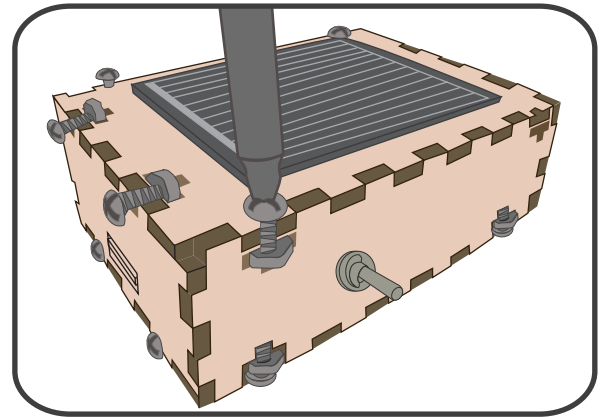

**YOU'RE FINISHED!!**

Please visit [www.BrownDogGadgets.com](http://www.BrownDogGadgets.com) for more great ideas & info.

## CIRCUIT DIAGRAMS

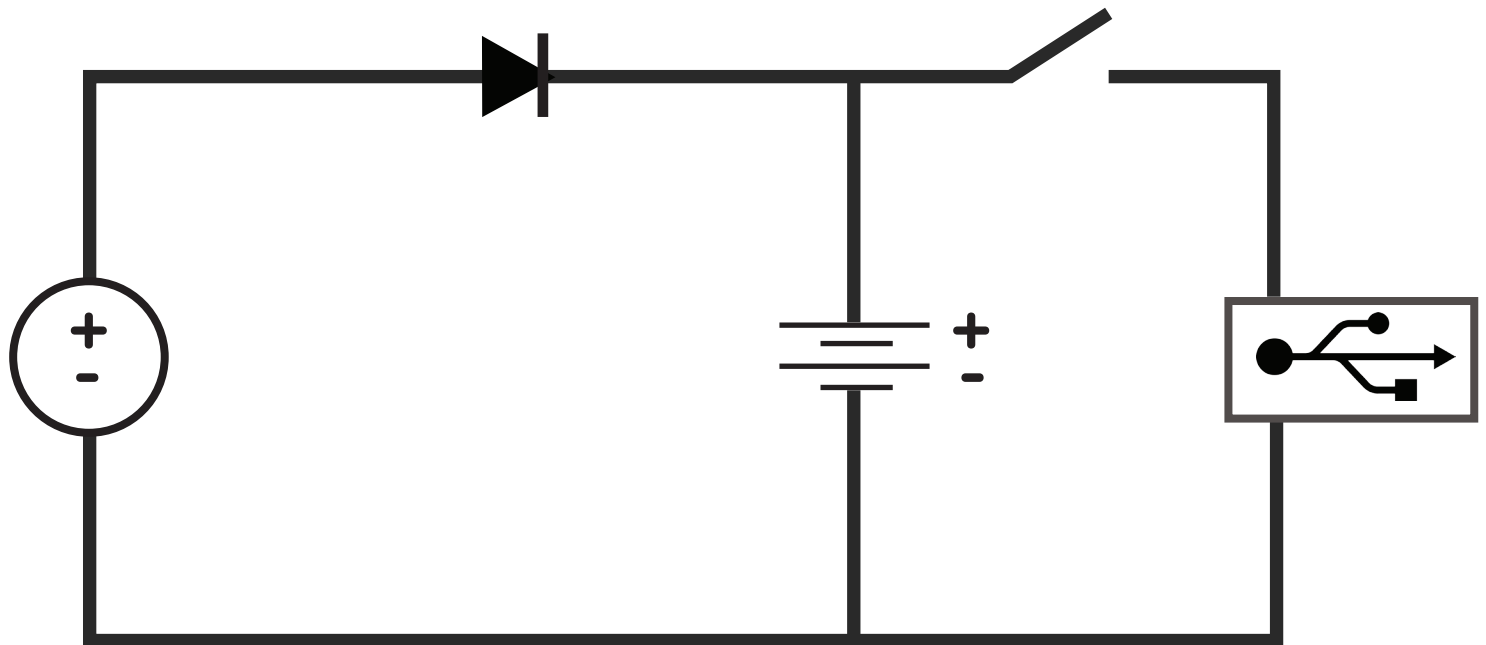
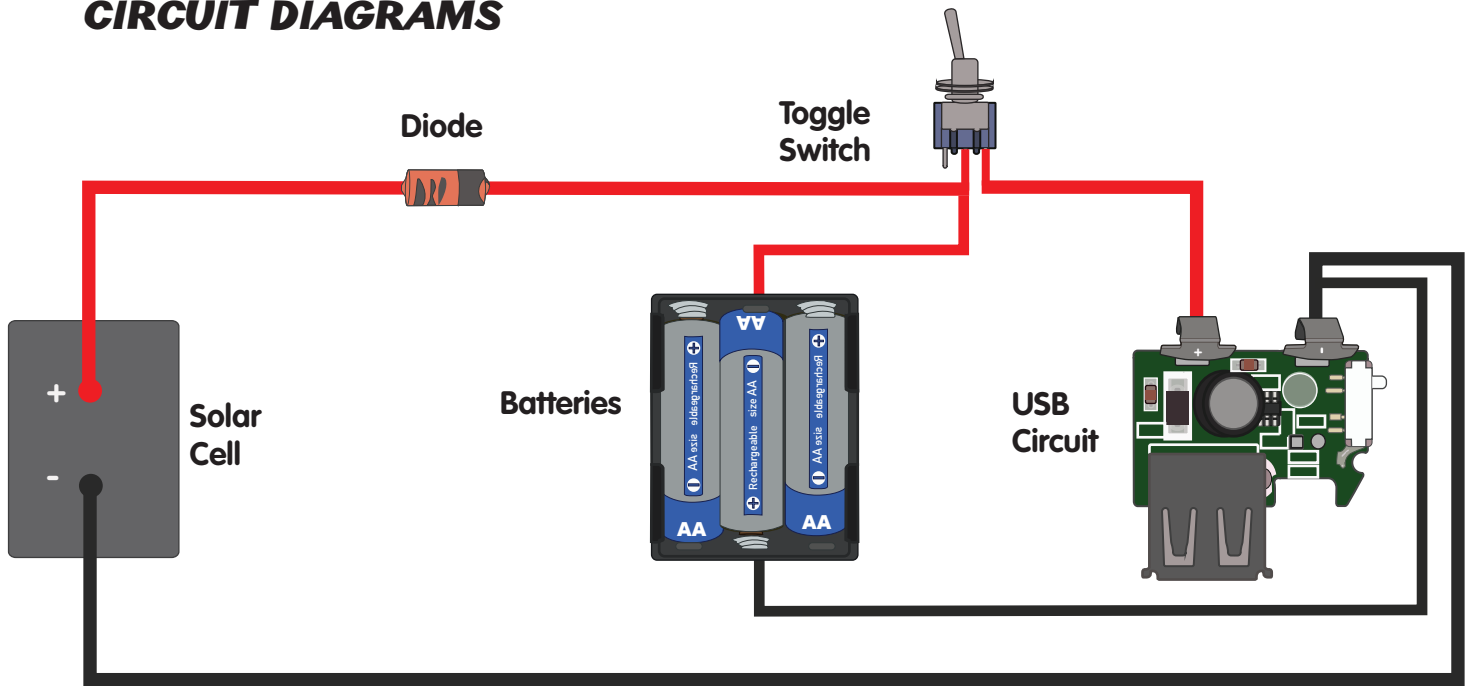

## TROUBLESHOOTING

1. Check the switch on the USB Circuit (step 10)
2. Try a different device. Some devices are not compatible with the USB circuit.
3. Check the batteries:
  1. Are they firmly in place and pointing in the correct direction?
  2. Do they have a charge? You can check this with a digital multimeter.
4. Check your solder points for short circuits or loose connections
5. Make sure your diode is aligned properly.