

CityRabbit™

USER MANUAL

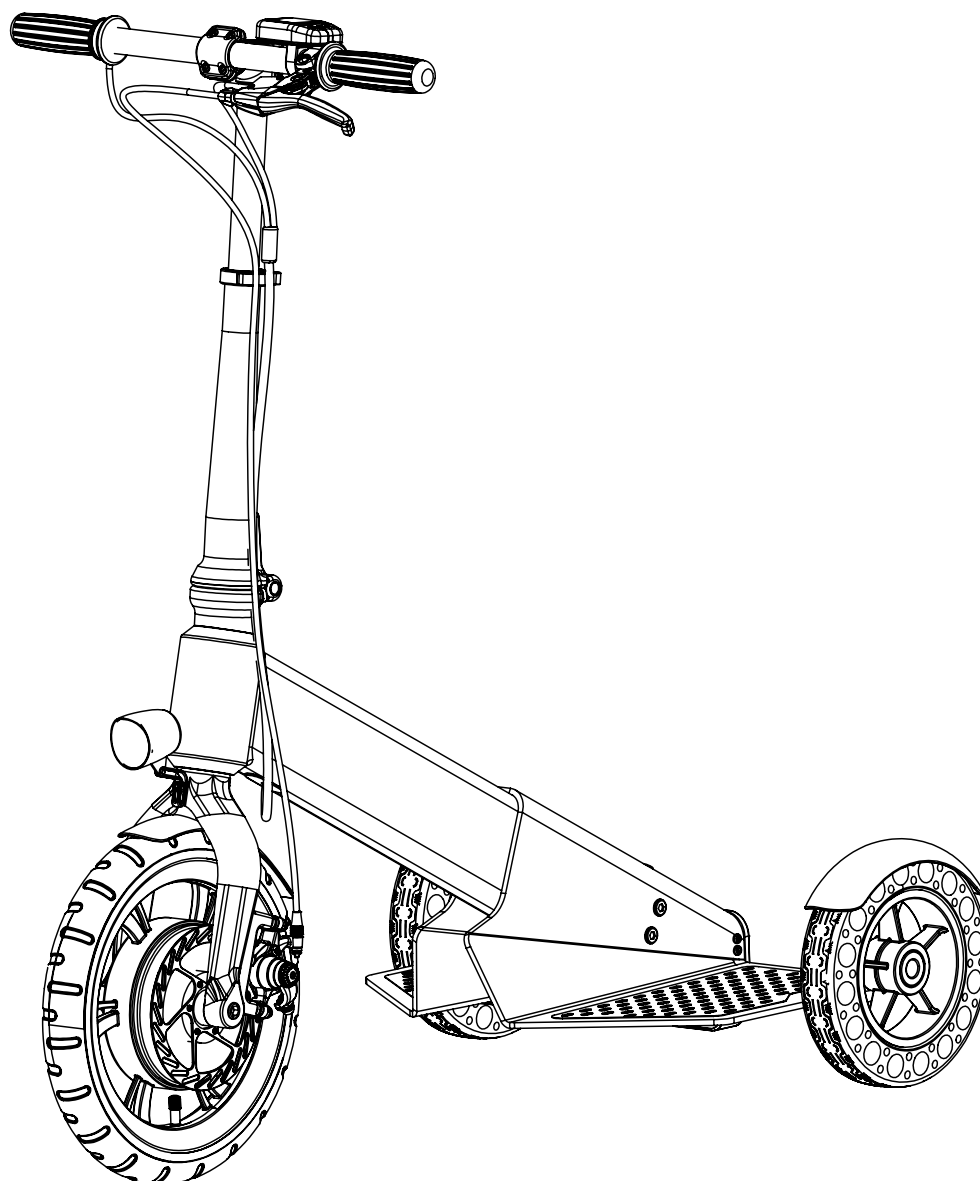

SAFETY PRECAUTIONS

1. Do not attempt to ride up or down stairs, or jump over obstacles
2. Do not ride in a ponding that is higher than 2 cm (0.78 inches)
3. Do not ride with anyone else, including children
4. Do not keep your hand away from handlebar
5. Do not ride in heavy rain



Wear a helmet and knee pads in case of falls and injuries when you learn to ride the scooter

HOW TO RIDE

1. Step on the deck with both feet placed in front of the two rear wheels

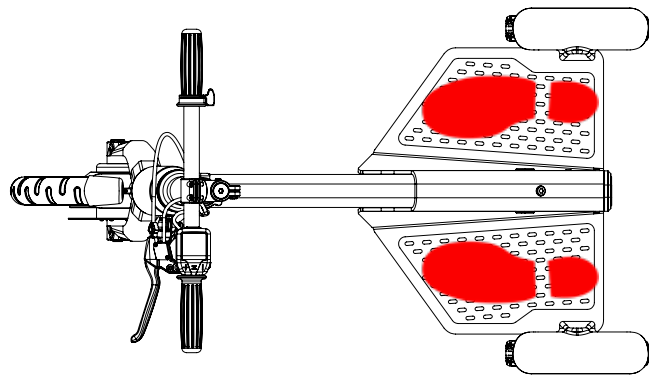

2. Press the accelerator down to initiate speed

3. Press the brake lever to initiate braking

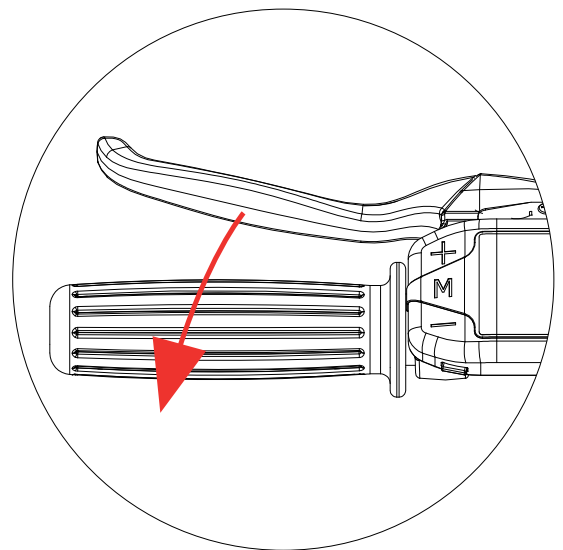
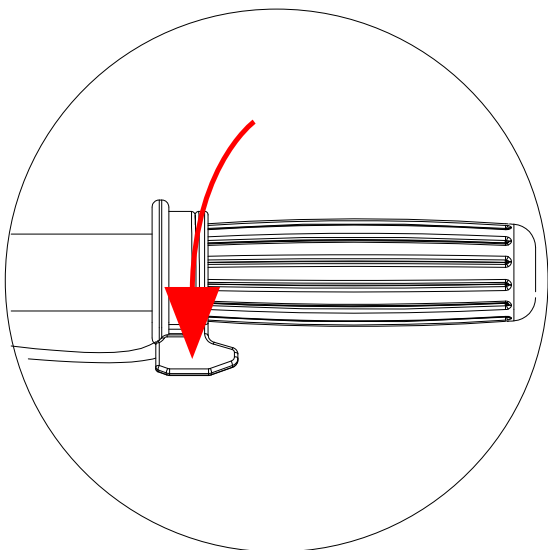

DISPLAY

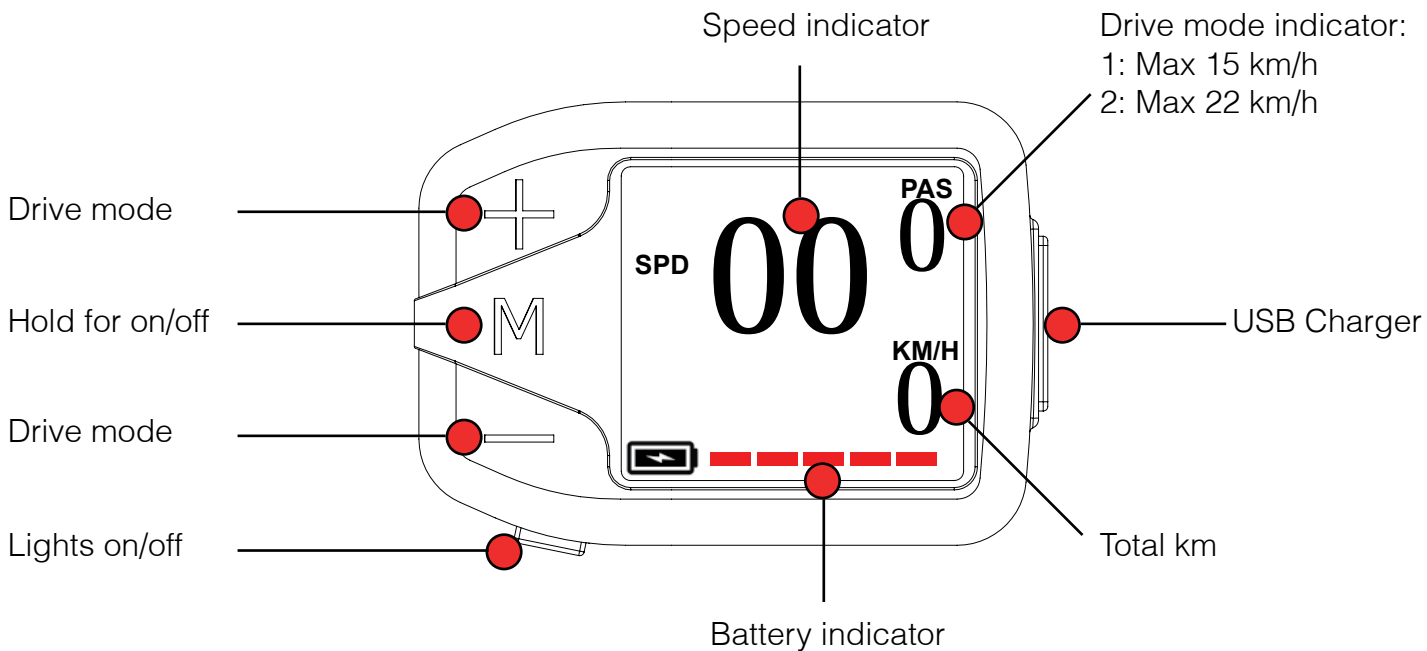

App



Lock bike

Lights on/off

Drive mode

Scan for Android



Scan for iPhone



CHARGE AND ADJUSTMENTS

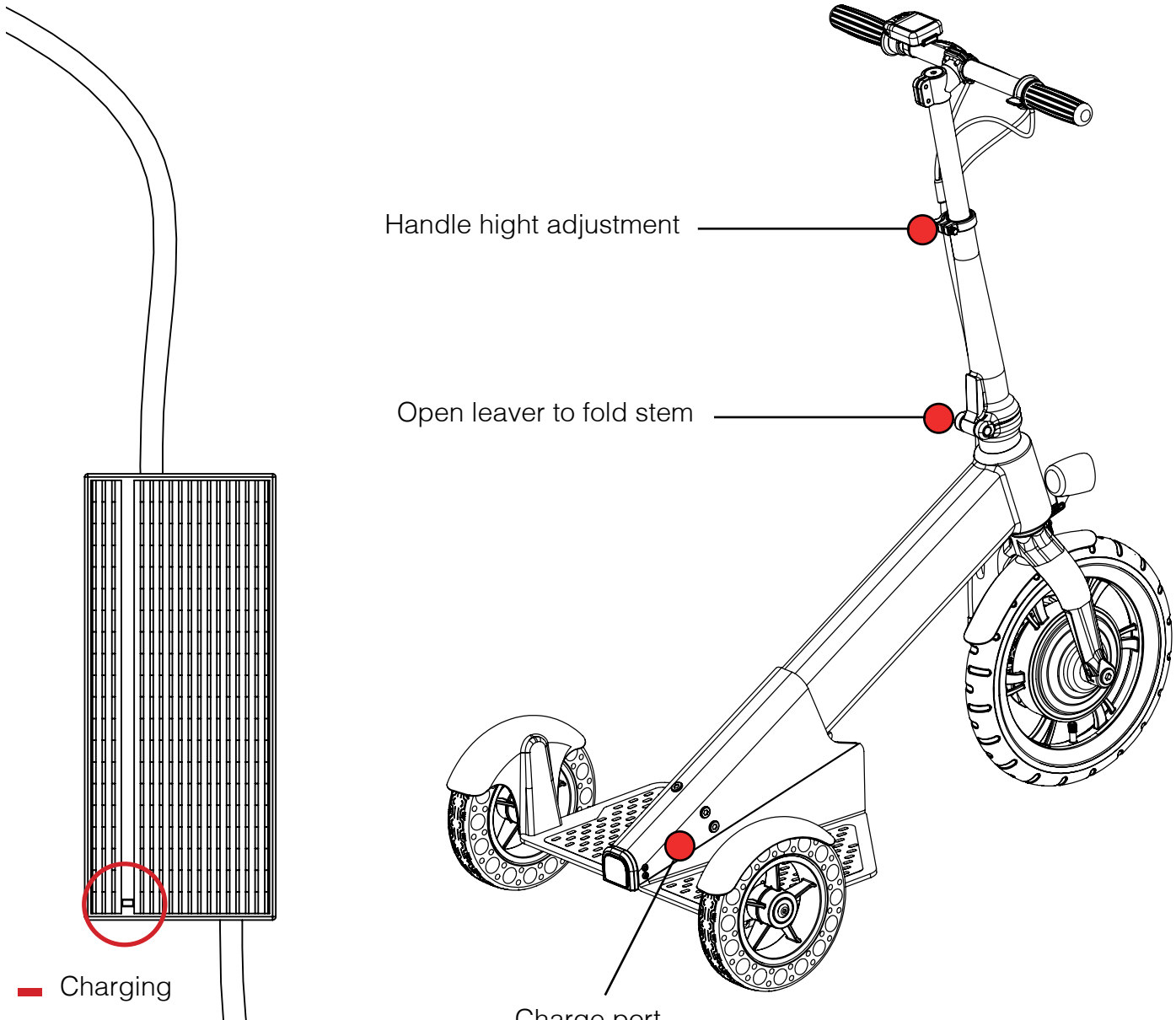

Handle height adjustment

Open lever to fold stem

Charge port.

— Charging

— Full/disconnected

NB: Do not leave unattended while charging.

BY: CITY MOBILITY CREW AS
MODEL NR.: CR-V1
RATED POWER: 300W
INPUT VOLTAGE: 36V
BATTERY: LG 7.8AH
MOTOR: 300W
MAX SPEED: 22 KM/H (15,5 MPH)
MAX LOAD: 120 KG

SERIAL NR.: _____

APP ID: _____

