

ERGON[®]

LIVING

FOLDING

TECHNICAL MANUAL - CONSTRUCTION AND INSTALLATION
Swinging sliding Folding pivot door with adjustable external frame
Up to 6 door leaves

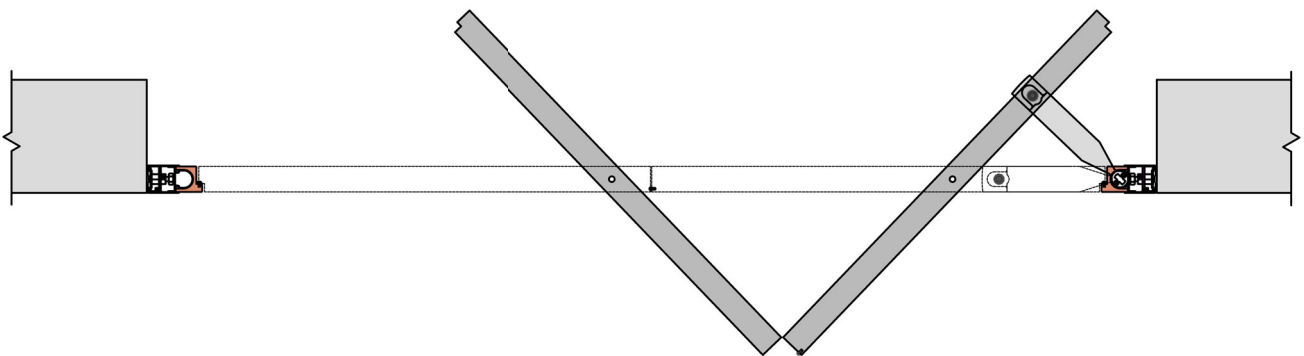

INDEX

Introduction	pag. 3
Parts list	pag. 4
Accessories	pag. 5
Equipments	pag. 6
Horizontal sections	pag. 7
Legend for dimensional drawings	pag. 8
Horizontal dimensional drawings - equipments with 2 doors leaf	pag. 8
Horizontal dimensional drawings - equipments with 3 doors leaf	pag. 9
Horizontal dimensional drawings - equipments with 4 doors leaf	pag. 10
Horizontal dimensional drawings - equipments with 5 doors leaf	pag. 11
Horizontal dimensional drawings - equipments with 6 doors leaf	pag. 12
Vertical ceiling sections	pag. 13
Ceiling vertical dimensional drawings	pag. 14
Vertical section on false ceiling	pag. 15
Vertical dimensional drawings on false ceiling	pag. 16
Working position according to the equipments "A; D; H; L"	pag. 17
Working position according to the equipments "B; E; I; M"	pag. 18
Working position according to the equipments "C; F; G"	pag. 19
Plate processing specification 155S e 155F1	pag. 20
Plate processing specification 155F2 e 155F3	pag. 21
Specifications of door leaf processing for gasket	pag. 22
Folding hinge kit exploded view (optional)	pag. 23
Folding hinge positioning (optional)	pag. 24
Workings doors leaf for Folding hinges (optional)	pag. 25
Folding hinge assembly (optional)	pag. 26
Folding door leaf locking options	pag. 27
"Soft Opening S1" installation	pag. 28
"Soft Opening Plus" installation	pag. 29

INTRODUCTION

Ergon Living FOLDING is an evolution of the Ergon Living T.E. system, it allows the rototranslating movement of several door leaves connected to each other by moving only the outermost door leaf, it has no floor guides and the movement is fluid and stable.

The system features an aluminum frame equipped with special adjustments to ensure correct installation

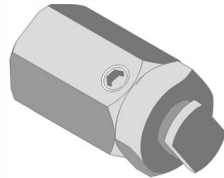

Patent pending











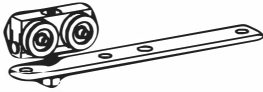

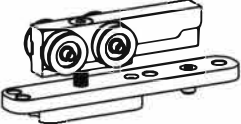
TECHNICAL FEATURES:

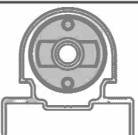
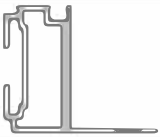



- Door leaf thickness from 1 19/32" to 2 3/16"
- Single leaf weight limit: 154 lbs
- Weight limit for folding door leaves: 110 lbs per door leaf
- Can be installed directly on the ceiling (see page 5) or on a false ceiling (see page 6)

DOWNLOAD ON www.celegon.it:



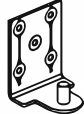

- Calculator for developing measurements and fittings: enter the wall opening width and height measurements, enter with or without false ceiling, select the desired fitting.
- Video animation for the correct installation of the whole system.

PARTS LIST

	Carriage for single door leaf Rif. 155S
	Carriage for 1^ folding door leaf Rif. 155F1
	Carriage for folding door leaves with adjustable plate Rif. 155F2
	Carriage for folding door leaves adjustable with plate and Soft Opening Rif. 155F3
	Upper and lower arm Rif. 185F
	Arm cap Rif. 186F
	Rod cover upright profile (with or without rod)
	External frame profile
	External frame profile cover
	Track profile Rif. 100F
	Track cover profile Rif. 145F
	Upper and lower arm plate Rif. 175.1
	Outer frame alignment plug Rif. 426F
	Clips for hooking the veil profile on external frame profile Rif. 397F
	Track cover fixing pin Rif. 250F

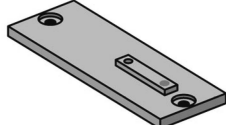
	Upper bracket Rif. 130F
	Lower bracket Rif. 195
	Hex screwdriver 3/32" Rif. 280
	Double 3 mm hex key for Folding carriage adjustment Rif. 405F
	Special hex key 9/32" for adjustable carriage Rif. 415F
	Sponge cleaner for track Rif. 420

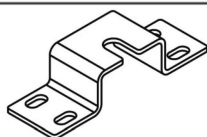
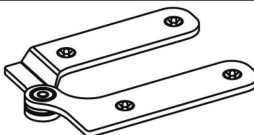
ACCESSORIES

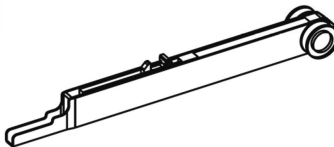
	Push&Go EVO striker plate Rif. 393 See p. 27
	Plate with threaded bar for false ceiling system Rif. 422F
	Omega plate for false ceiling system Rif. 424F
	Folding hinge (optional)
	Soft Opening S1 single leaf (optional) Rif. 410S
	Soft Opening Plus with folding door bearings (optional) Rif. 410F

ACCESSORIES

- FOLDING HINGES: assemblable and specially designed for the Folding system -

Item code:

C701000F1 BLACK

C721000F1 STAINLESS

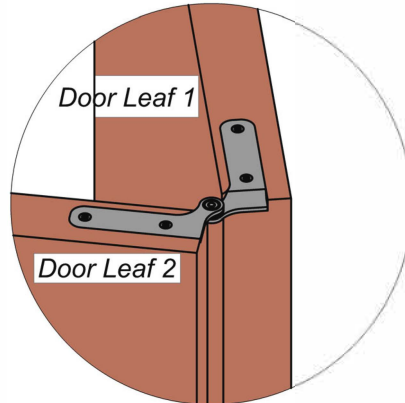

- SOFT OPENING S1: damper for single door leaf

- SOFT OPENING PLUS: damper for Folding door leaves

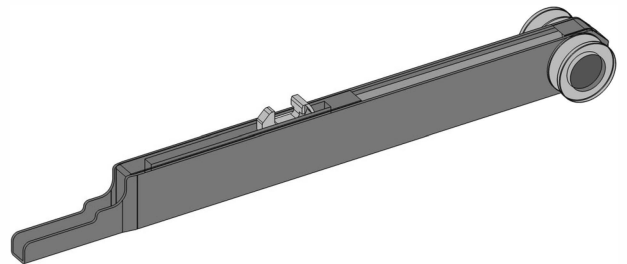
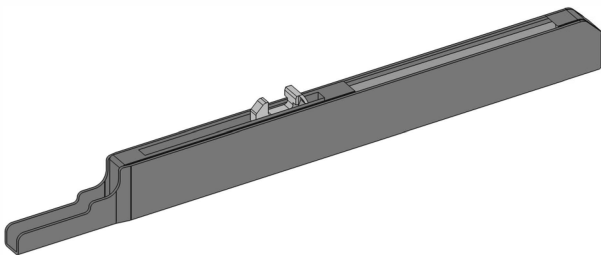

- BALLOON GASKET Ø9/32": see pag. 21 "leaf processing specifications for gasket"

Item code:

GS680--- (see price list)



- Push&Go EVO: Quick release system for Folding door leaves

Item code Push:

4100-- (see price list)

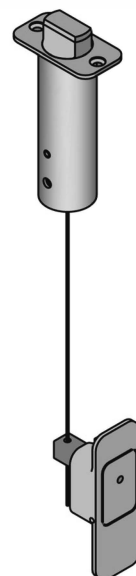
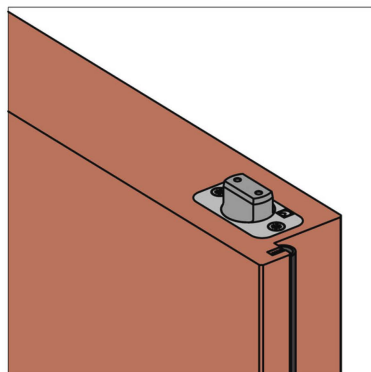

EQUIPMENTS



Equipment "A"

Single folding opening with 2 door leaves
Wall Hole Width: **Minimum 49" - Max 101 25/32"**



Equipment "B"

Double opening: single + folding with 2 door leaves
Wall Hole Width: **Minimum 75 7/32" - Max 148 13/16"**

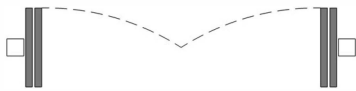

Equipment "C"

Double folding opening with 2 door leaves
Wall Hole Width: **Minimum 90 9/16" - Max 196 1/16"**

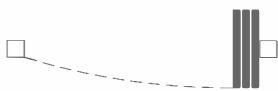

Equipment "D"

Single folding opening with 3 door leaves
Wall Hole Width: **Minimum 78 11/32" - Max 149 7/32"**



Equipment "E"

Double opening: single + folding with 3 door leaves
Wall Hole Width: **Minimum 99 5/8" - Max 196 1/16"**



Equipment "F"

Double opening: folding with 2 doors + folding with 3 door leaves
Wall Hole Width: **Minimum 115 5/32" - Max 243 1/2"**

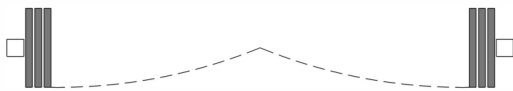

Equipment "G"

Double opening: single + folding with 3 door leaves
Wall Hole Width: **Minimum 139 25/32" - Max 257 7/8"**

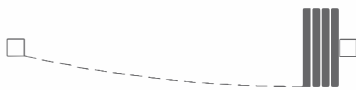

Equipment "H"

Single folding opening with 3 door leaves
Wall Hole Width: **Minimum 90 15/16" - Max 196 15/32"**



Equipment "I"

Double opening: single + folding with 4 door leaves
Wall Hole Width: **Minimum 117 1/8" - Max 243 1/2"**

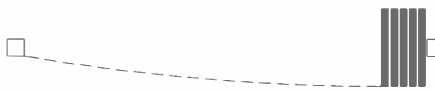

Equipment "L"

Single folding opening with 5 door leaves
Wall Hole Width: **Minimum 125 25/32" - Max 243 29/32"**



Equipment "M"

Double opening: single + folding with 5 door leaves
Wall Hole Width: **Minimum 144 3/32" - Max 257 7/8"**

Use the calculator to get all the measurements you need
For other setups, ask Celegon S.r.l. for feasibility.

HORIZONTAL SECTIONS

Horizontal section applied to the stile

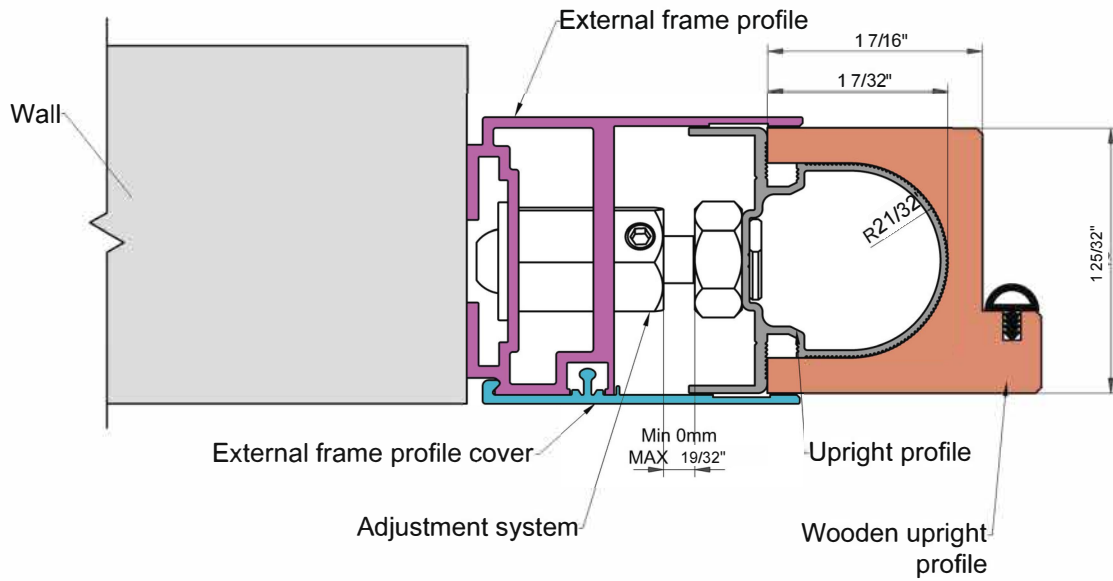

Horizontal section applied to the wall

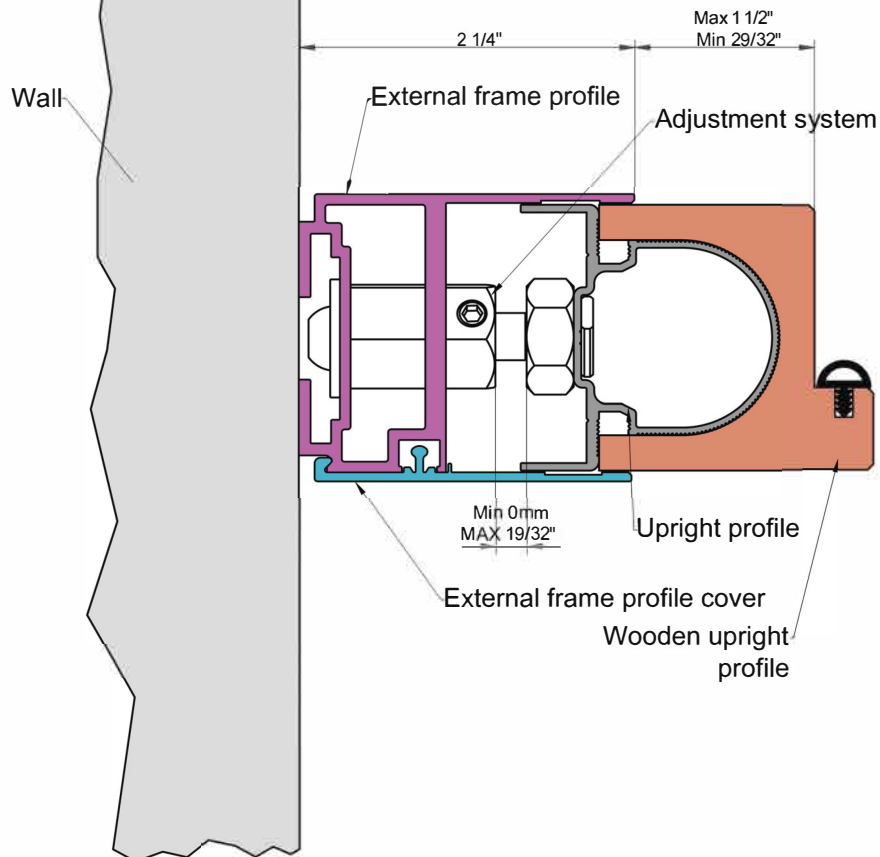

LEGEND FOR DIMENSIONAL DRAWINGS

- LFM** = WALL HOLE WIDTH
- LP** = PASSAGE DIMENSION
- LPD** = DOUBLE PASSAGE DIMENSION
- LS** = DOOR JAMB OPENING
- LA1** = SINGLE DOOR WIDTH
- LA2** = DOOR WIDTH WITH TWO CONSECUTIVE DOOR LEAVES
- LA3** = DOOR WIDTH WITH THREE CONSECUTIVE DOOR LEAVES
- LA4** = DOOR WIDTH WITH FOUR CONSECUTIVE DOOR LEAVES
- LA5** = DOOR WIDTH WITH FIVE CONSECUTIVE DOOR LEAVES
- QF = QC** = FIXED DIMENSION ENCUMBRANCE ARM-SIDE = CARRIAGE DIMENSION (391,3)
- QV** = VARIABLE DIMENSION ENCUMBRANCE HANDLE-SIDE
- HP** = PASSAGE HEIGHT DIMENSION
- HA** = DOOR LEAF HEIGHT
- HFM** = WALL HOLE HEIGHT
- HC** = FALSE CEILING HEIGHT

HORIZONTAL DIMENSIONAL DRAWINGS - EQUIPMENTS WITH 2 DOOR LEAVES

EQUIPMENT "A"

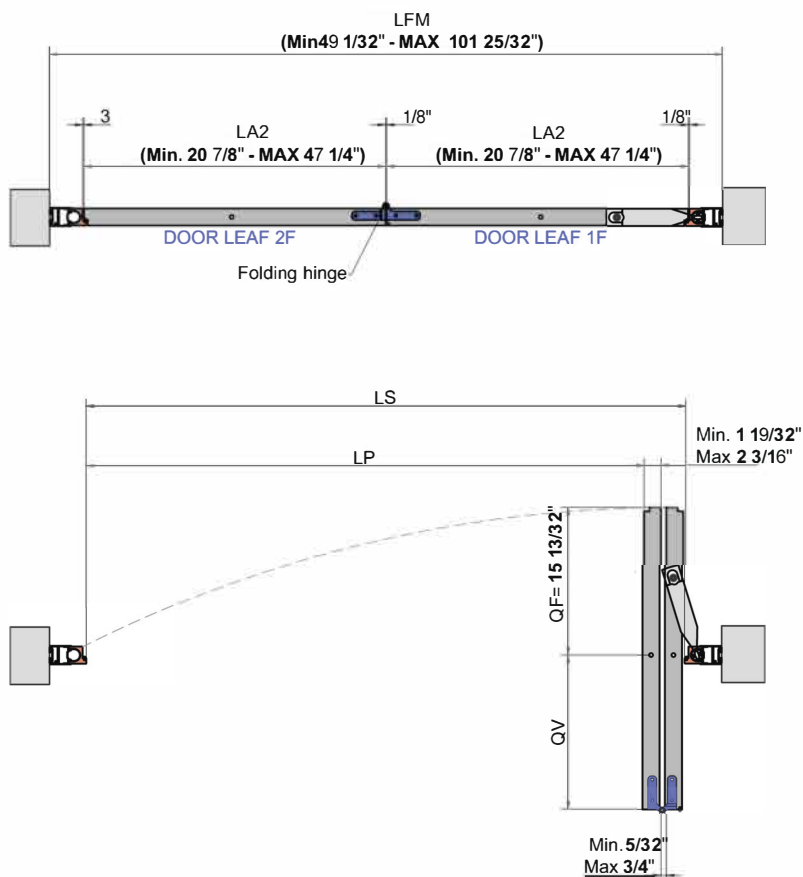

HORIZONTAL DIMENSIONAL DRAWINGS - EQUIPMENTS WITH 3 DOOR LEAVES

EQUIPMENT "B"

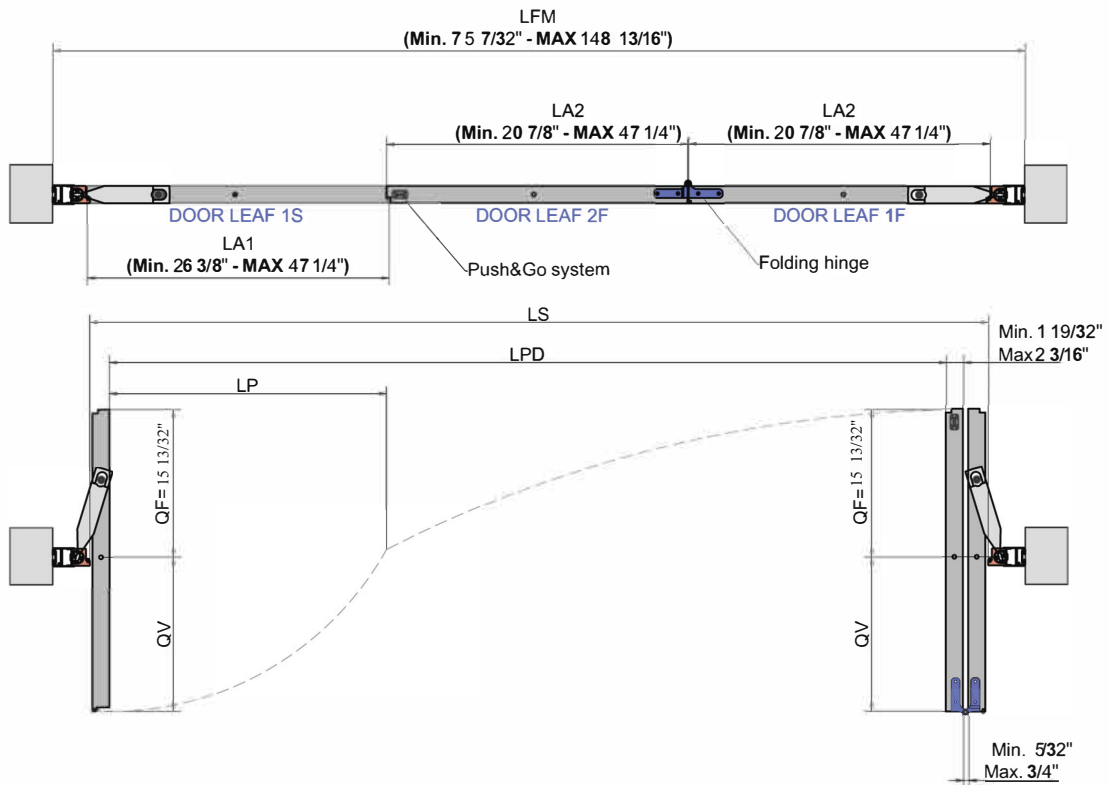

EQUIPMENT "D"

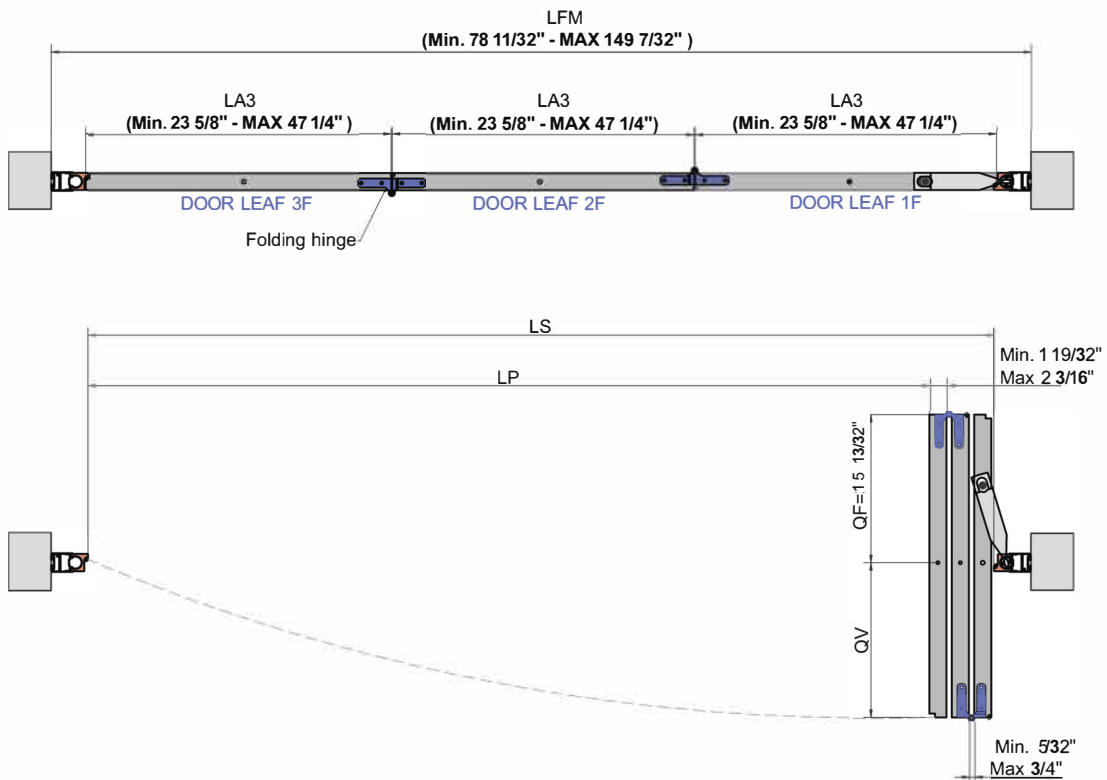

HORIZONTAL DIMENSIONAL DRAWINGS - EQUIPMENTS WITH 4 DOOR LEAVES

EQUIPMENT "C"

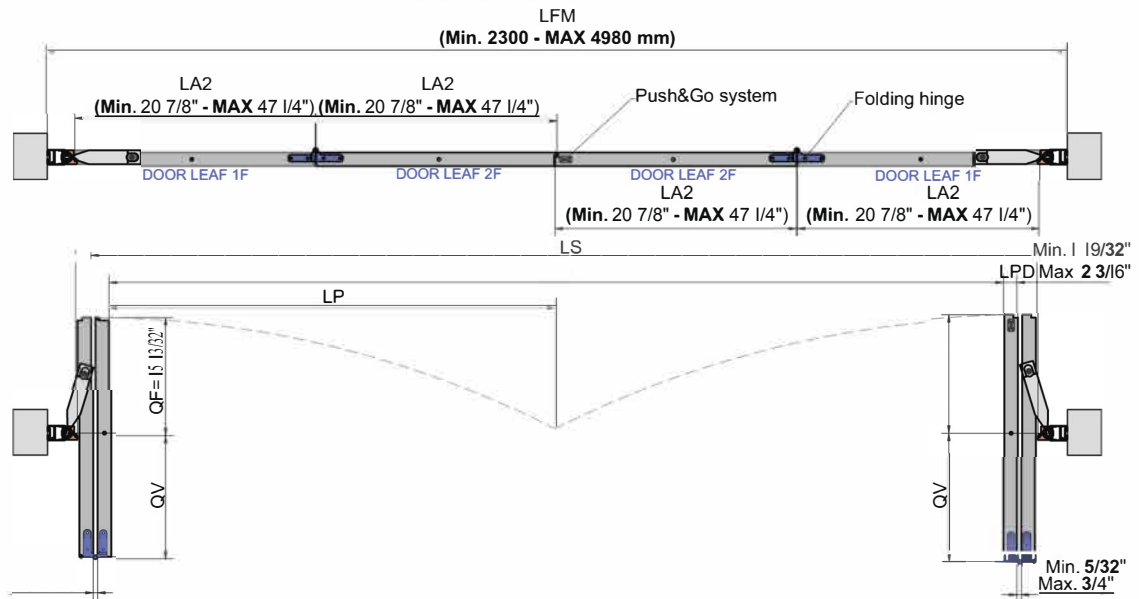

EQUIPMENT "E"

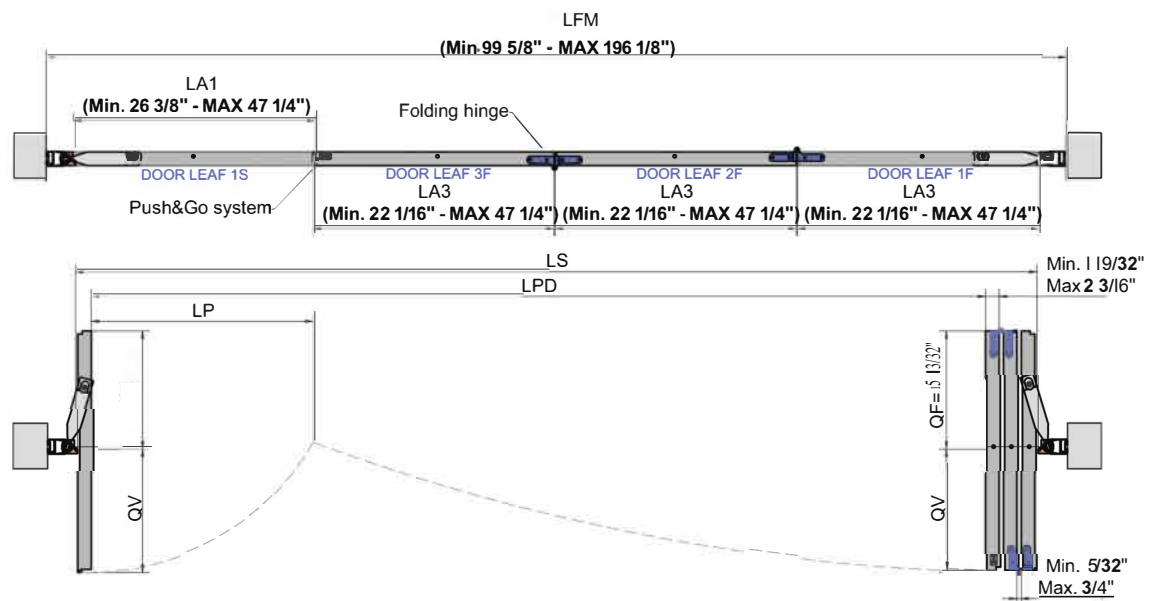

EQUIPMENT "H"

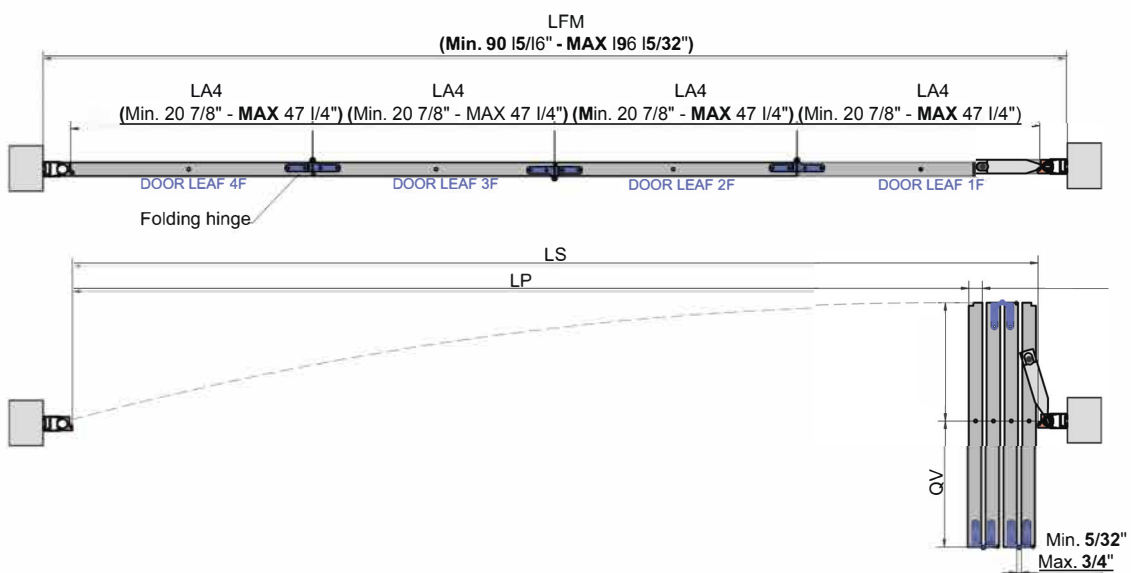

HORIZONTAL DIMENSIONAL DRAWINGS - EQUIPMENTS WITH 5 DOOR LEAVES

EQUIPMENT "F"

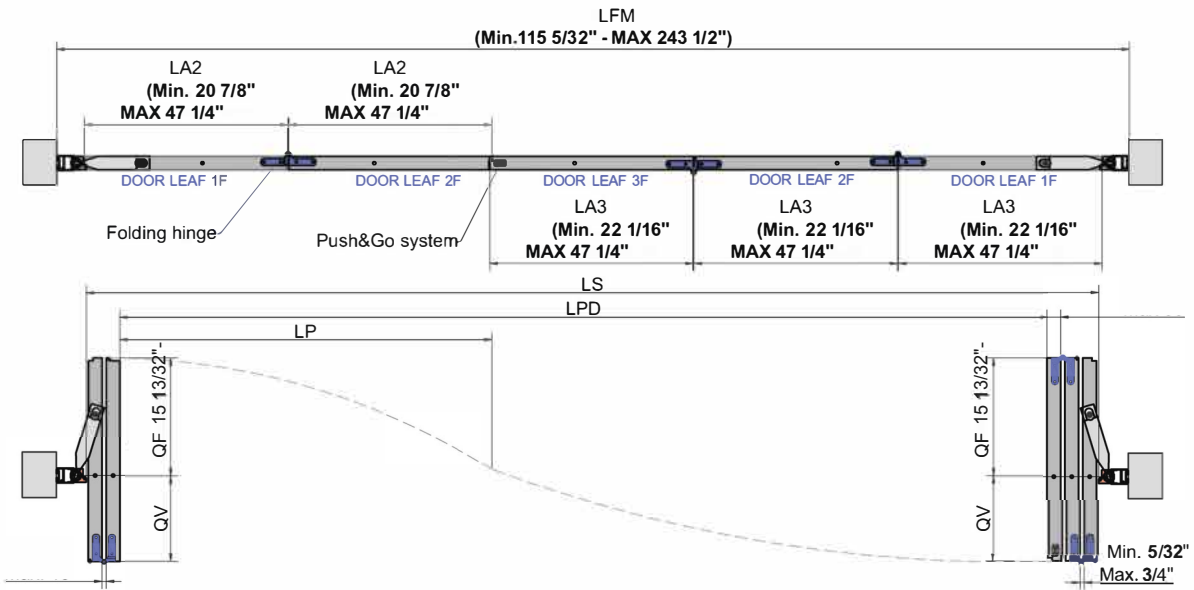

EQUIPMENT "I"

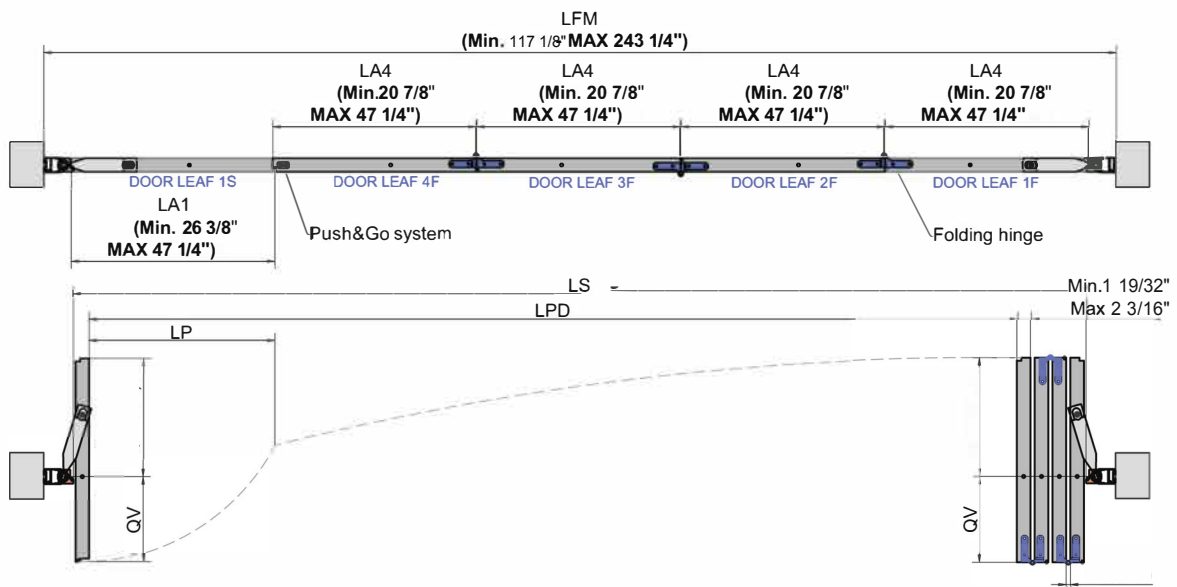

EQUIPMENT "L"

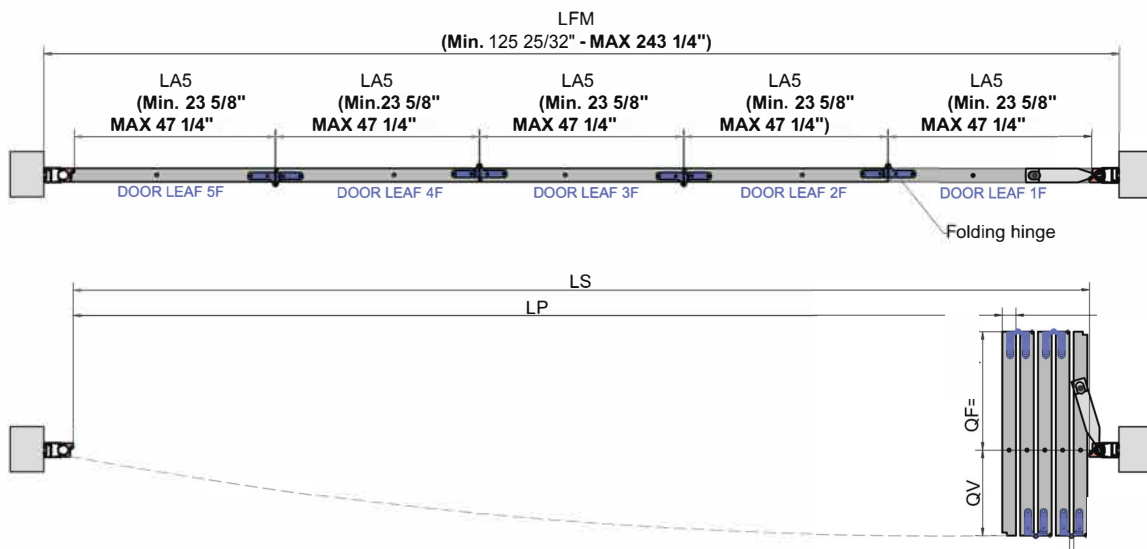

HORIZONTAL DIMENSIONAL DRAWINGS - EQUIPMENTS WITH 6 DOOR LEAVES

EQUIPMENT "G"

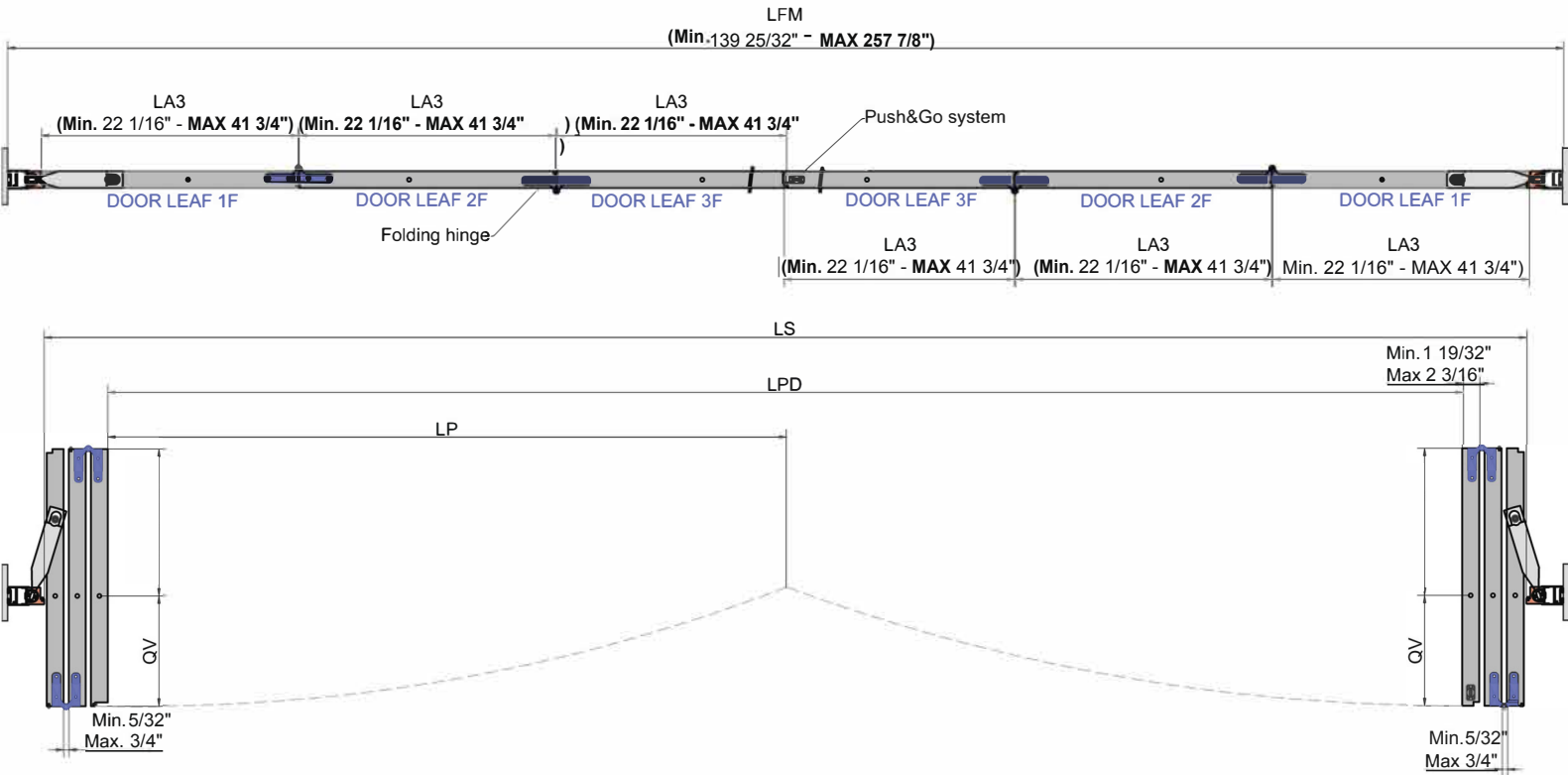

EQUIPMENT "M"

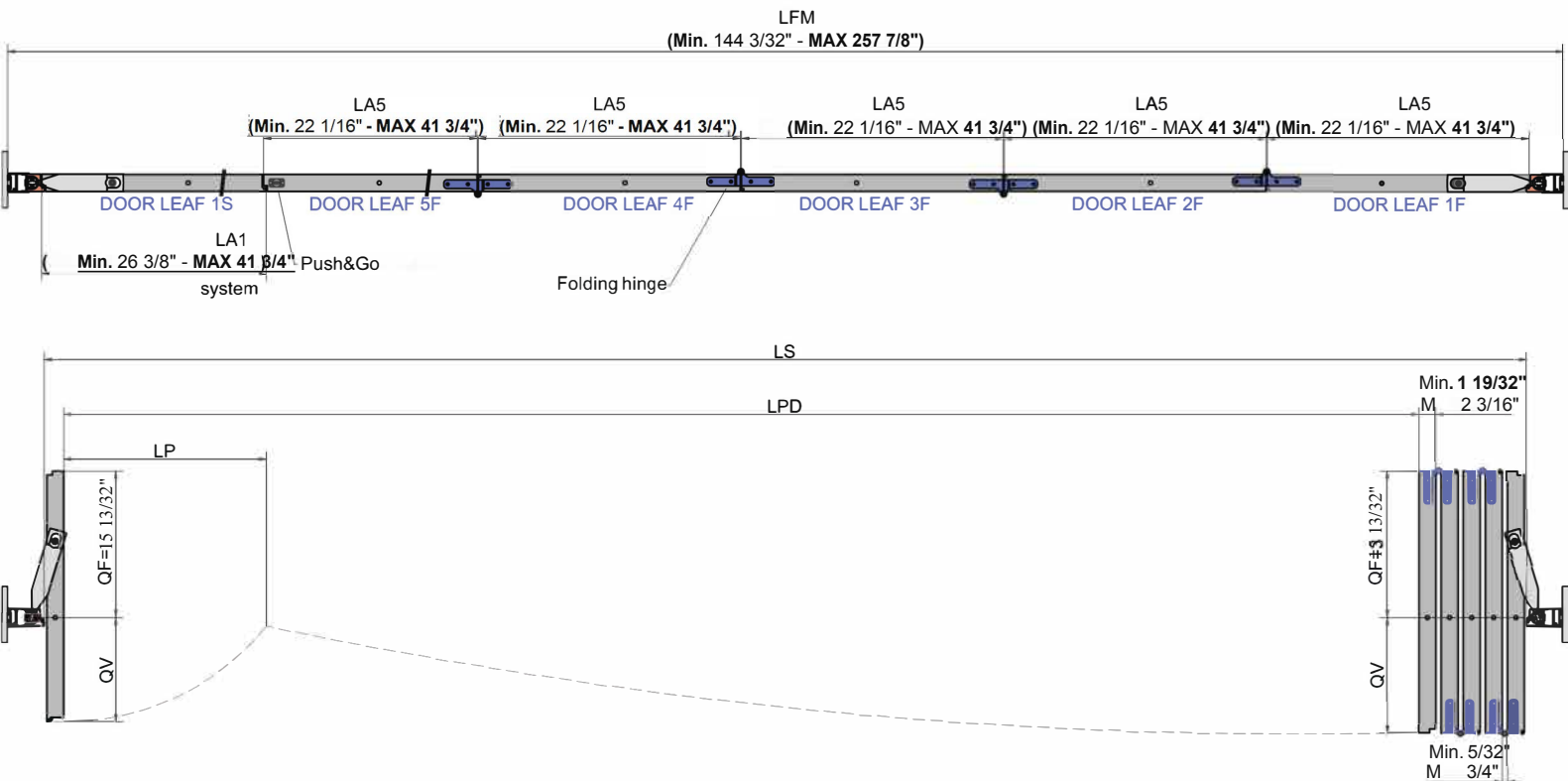

VERTICAL CEILING SECTIONS

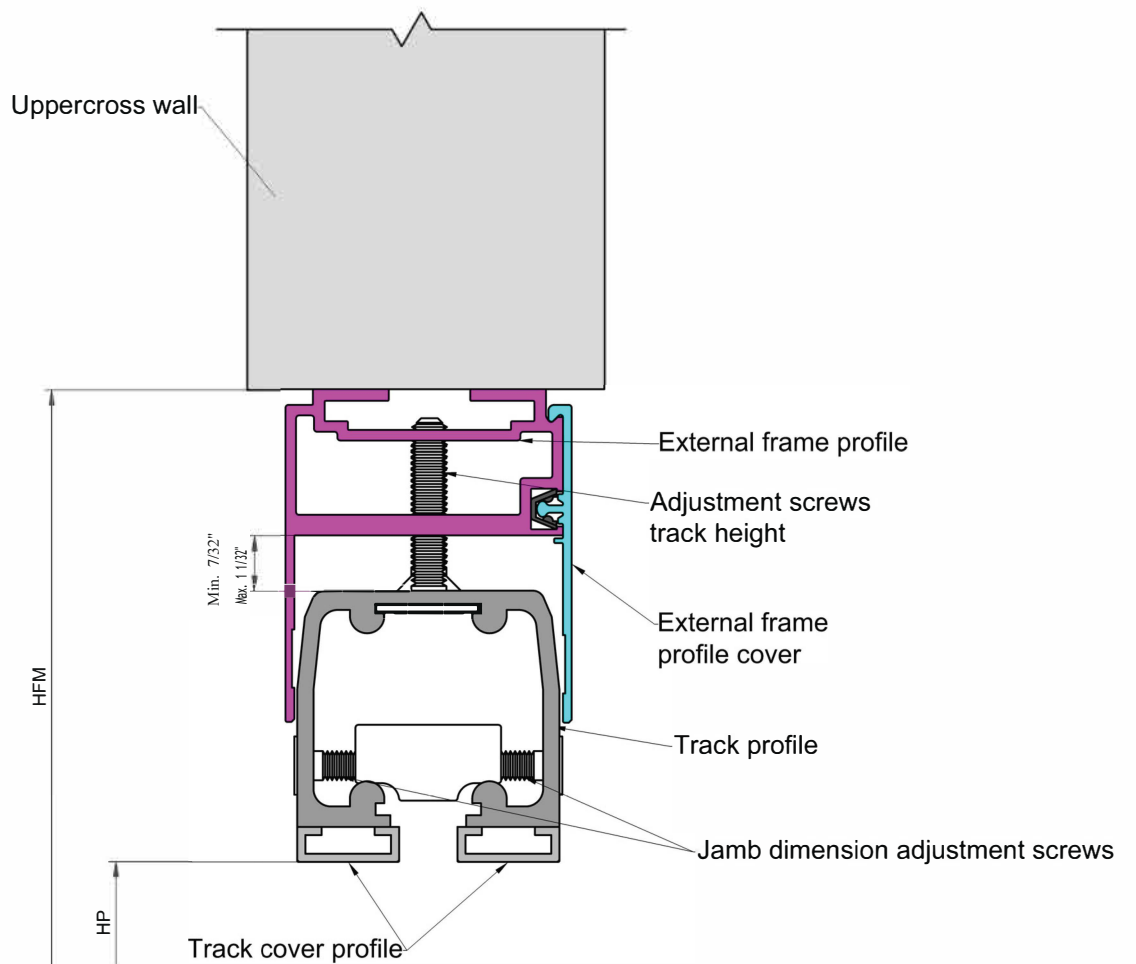
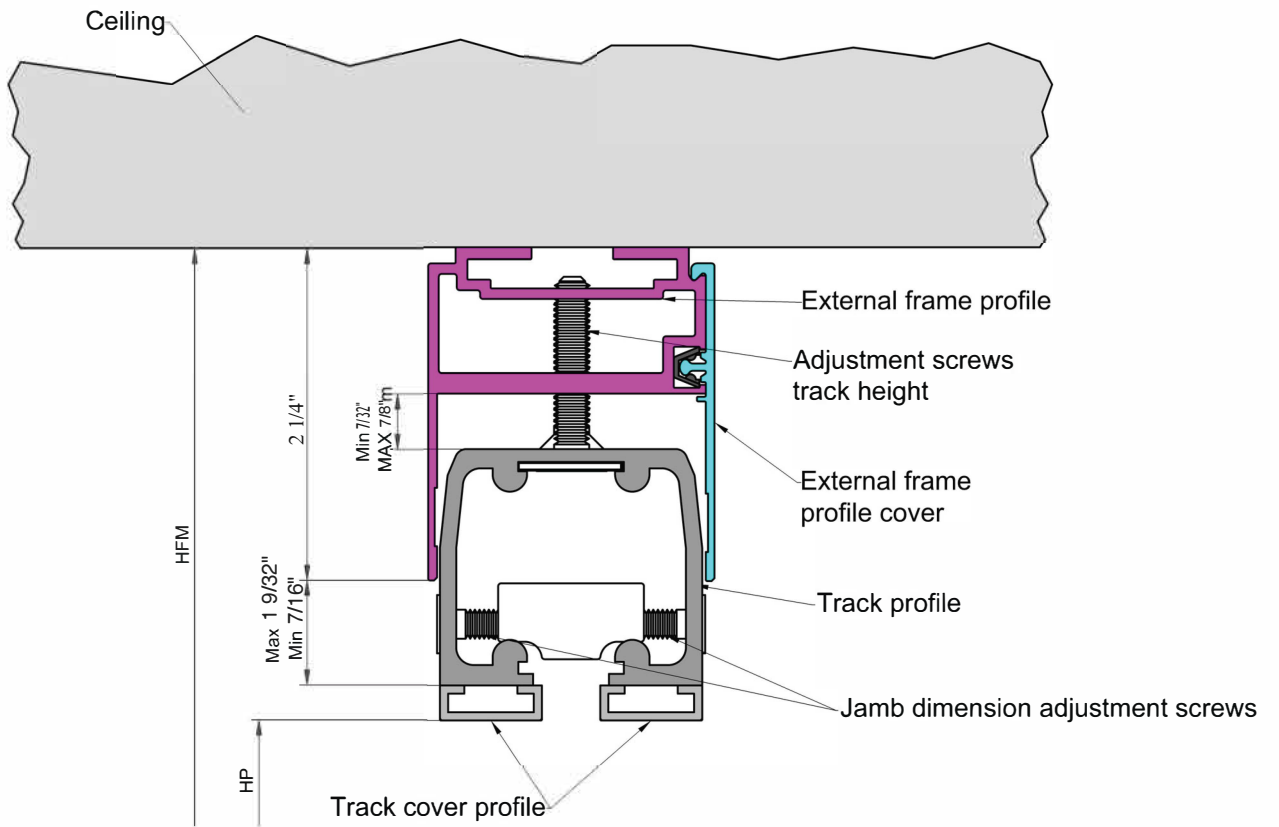

VERTICAL DIMENSIONAL DRAWINGS ON THE CEILING

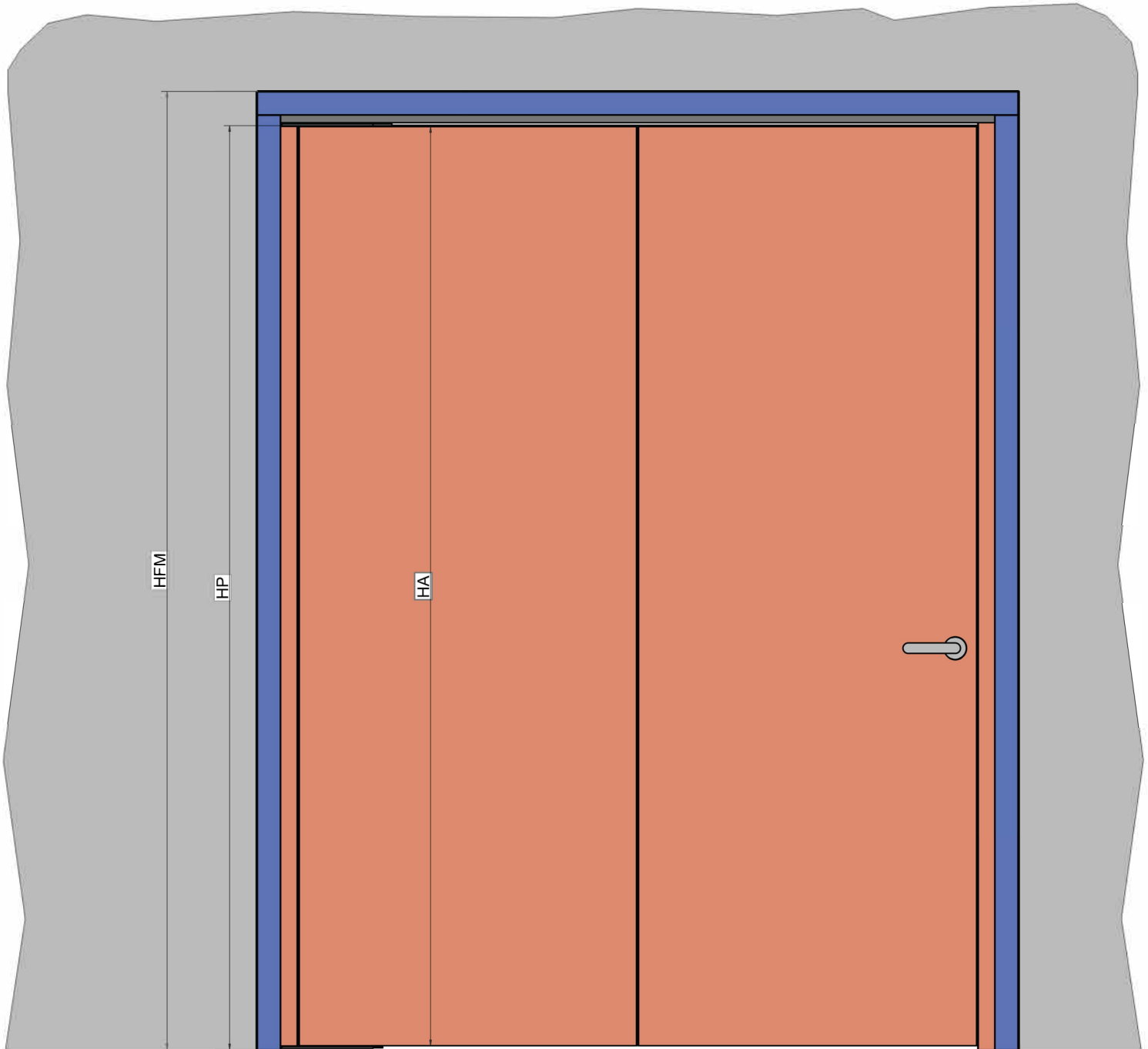

$HP = HFM - 2 \frac{31}{32}''$

$HA = HFM - 3 \frac{5}{8}''$

When ordering the rod kit, the wall opening size (HFM) must be provided. According to the communicated dimensions will be supplied a customised rod kit

Max size HFM $123 \frac{1}{32}''$

Max size HP $120 \frac{3}{32}''$

For larger sizes, ask Celegon S.r.l. for feasibility.

VERTICAL SECTION ON FALSE CEILING

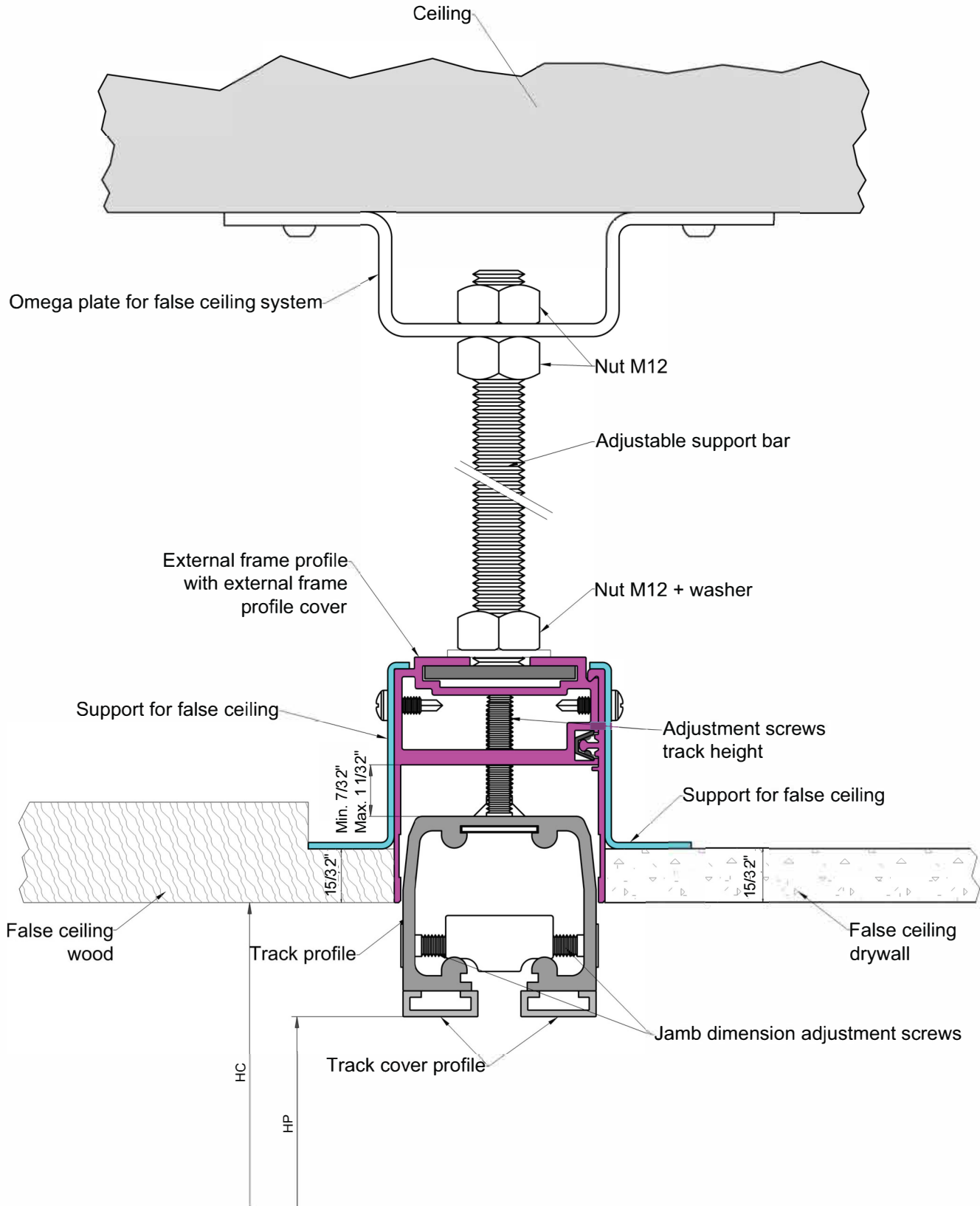

VERTICAL DIMENSIONAL DRAWINGS ON THE FALSE CEILING

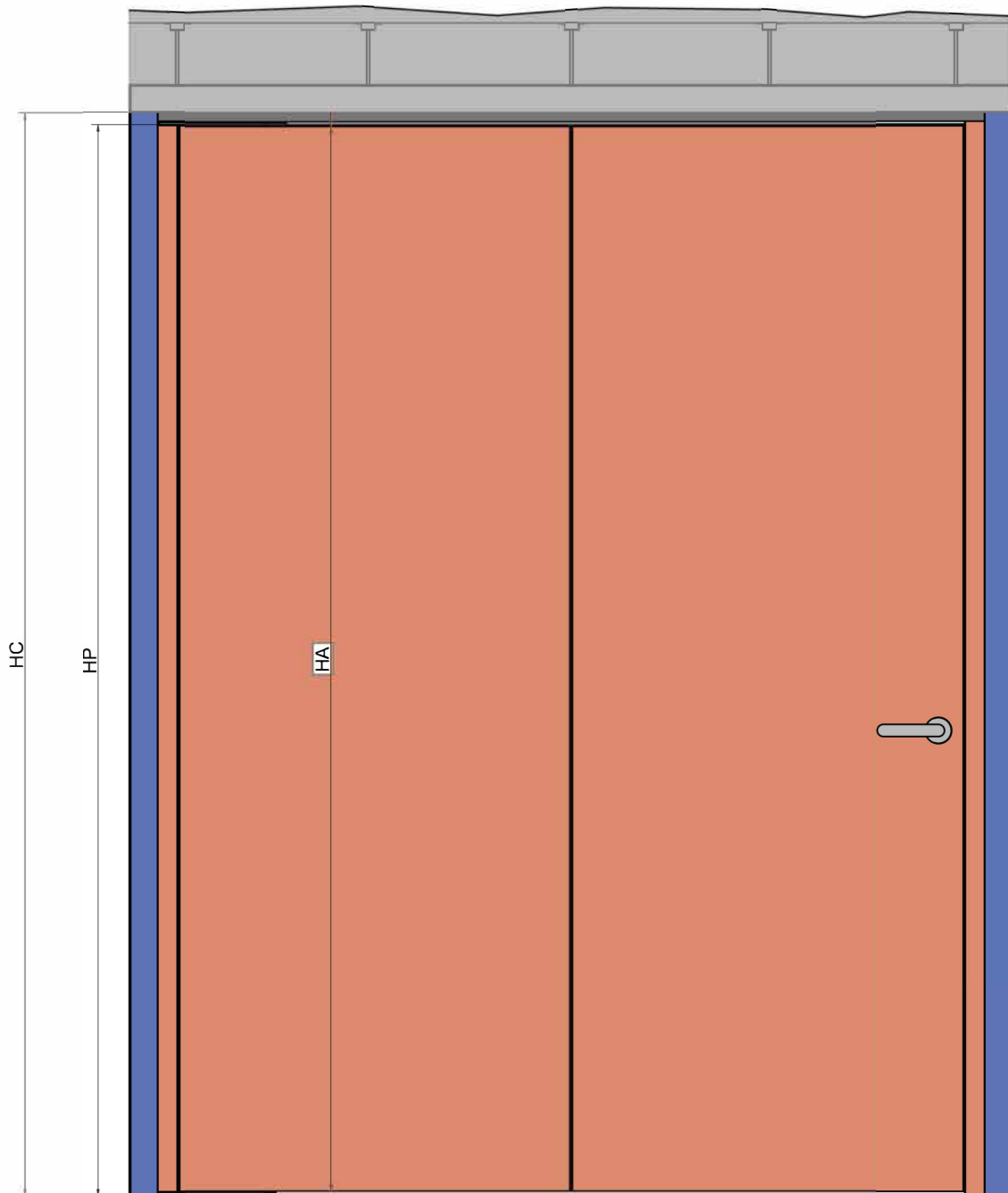

$$HP = HC - 23/32''$$

$$HA = HC - 1 \frac{3}{8}''$$

When ordering the rod kit, the measurement of the height of the false ceiling (HC) must be provided.

According to the communicated dimensions will be supplied a customised rod kit

Max size HC 120 $25/32''$

Max size HP 120 $3/32''$

For larger sizes, ask Celegon S.r.l. for feasibility.

PROCESSING POSITION ACCORDING TO THE EQUIPMENTS "A; D; H; L"

Single openings: Folding

EQUIPMENT "A" - Folding with 2 door leaves

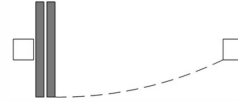
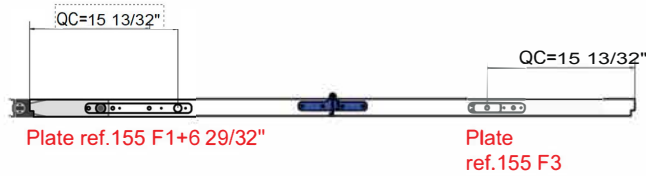

EQUIPMENT "D" - Folding with 3 door leaves

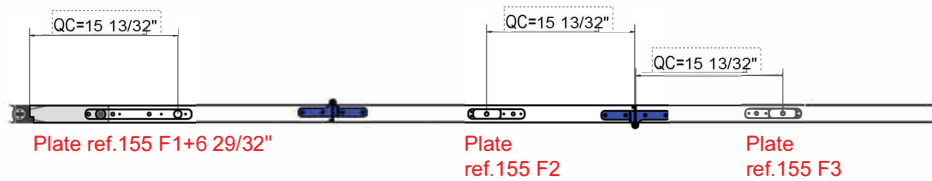

EQUIPMENT "H" - Folding with 4 door leaves

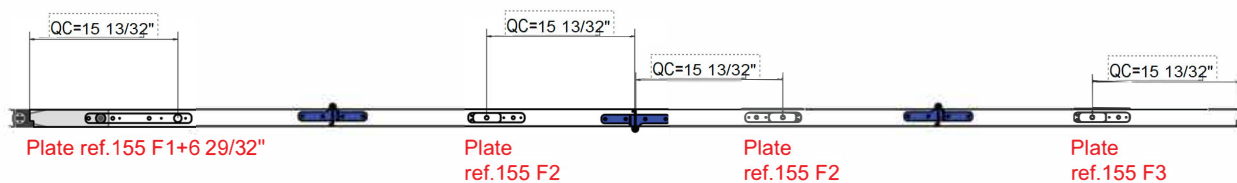

EQUIPMENT "L" - Folding with 5 door leaves

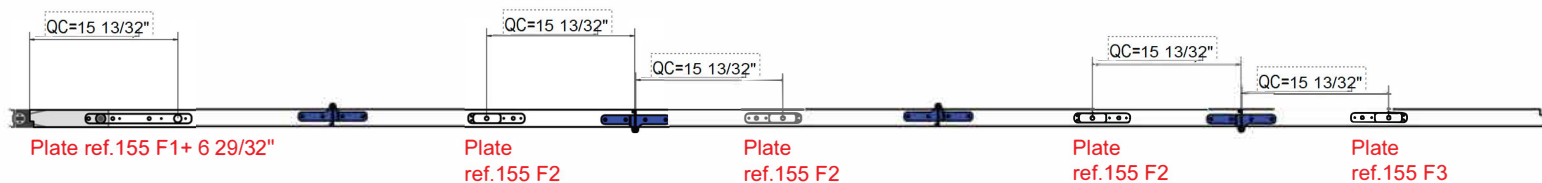

PROCESSING POSITION ACCORDING TO THE EQUIPMENTS "B; E; I; M"

Double openings: Folding + single

EQUIPMENT "B" - Single + folding with 2 door leaves

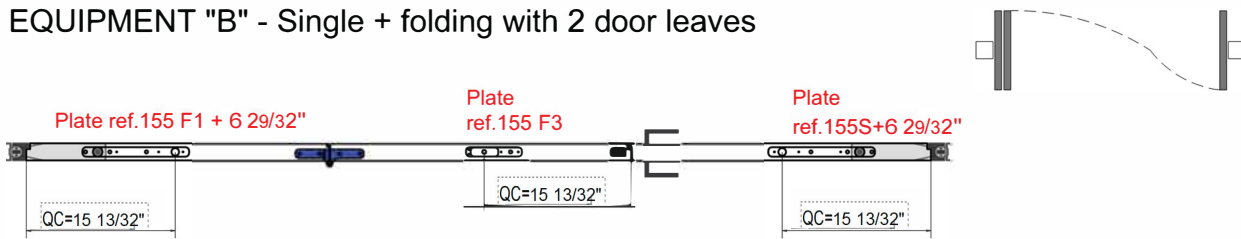

EQUIPMENT "E" - Single + folding with 3 door leaves

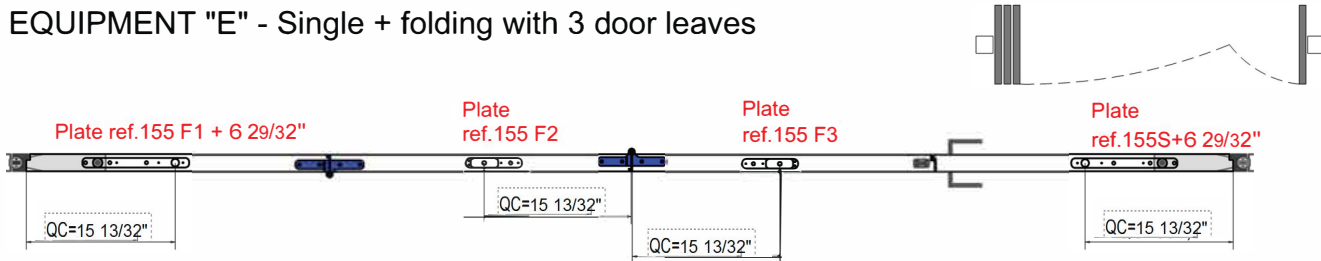

EQUIPMENT "I" - Single + folding with 4 door leaves

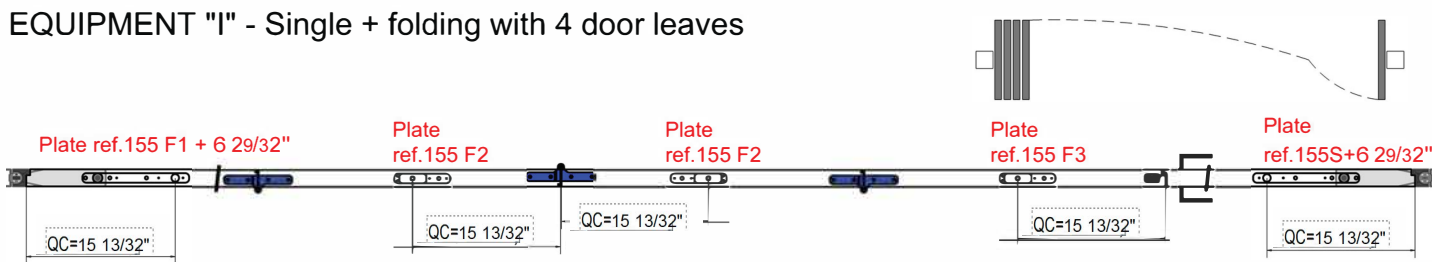

EQUIPMENT "M" - Single + folding with 5 door leaves

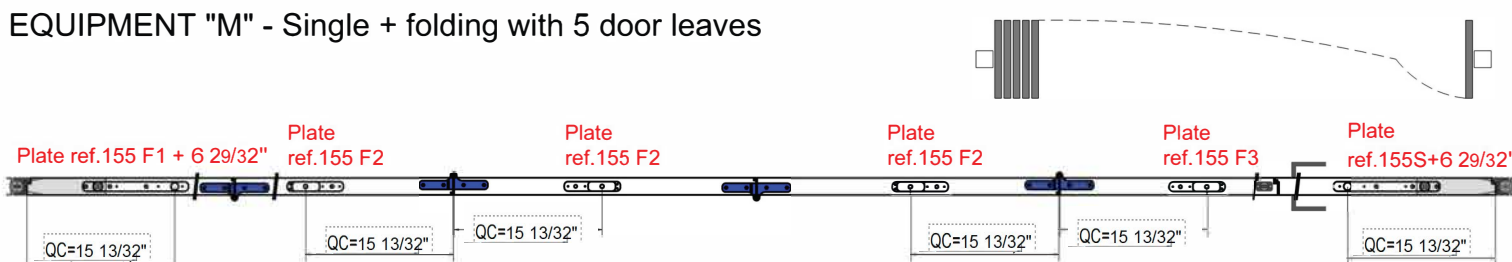

PROCESSING POSITION ACCORDING TO THE EQUIPMENTS "C; F; G"

Double openings: Folding

EQUIPMENT "C" - Folding with 2 door leaves + 2 door leaves

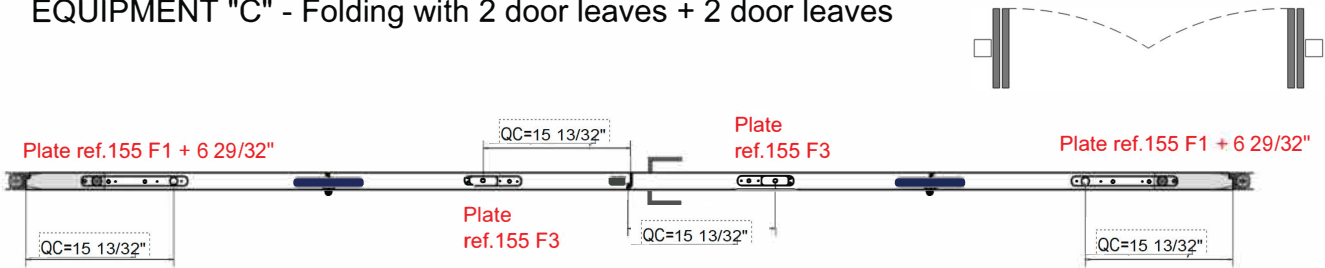

EQUIPMENT "F" - Folding with 3 door leaves + 2 door leaves

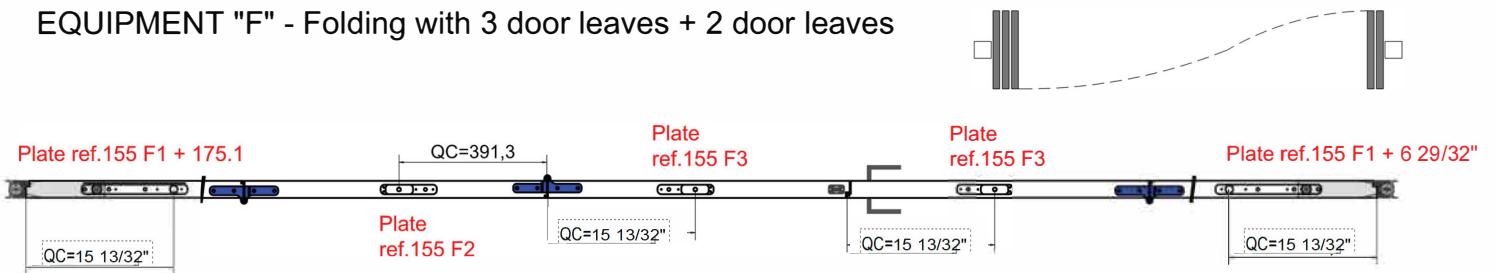

EQUIPMENT "G" - Folding with 3 door leaves + 3 door leaves

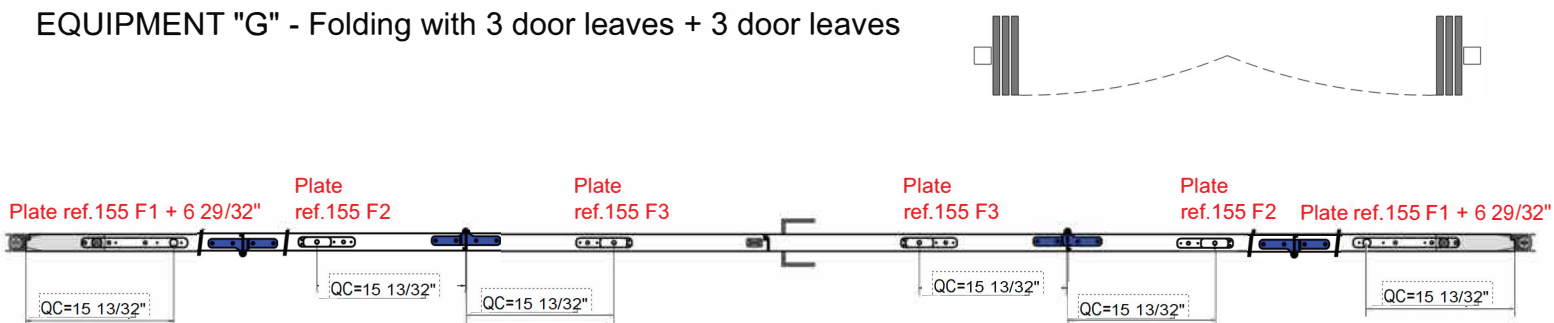

155S and 155F1 PLATE PROCESSING SPECIFICATIONS

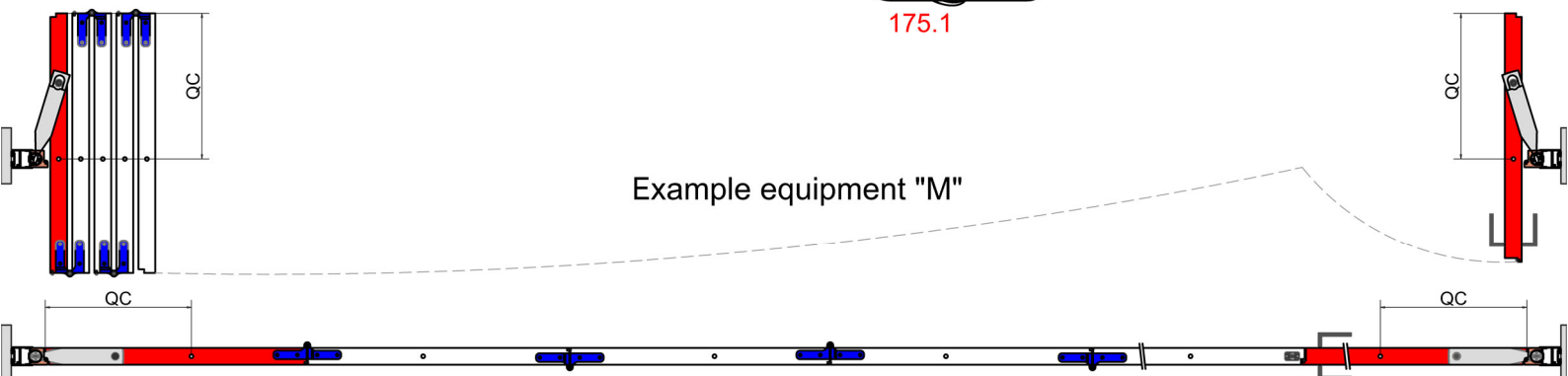
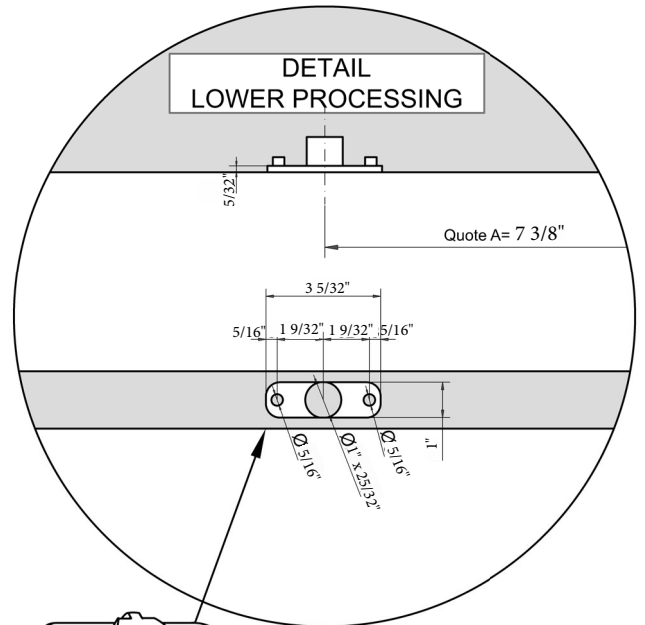
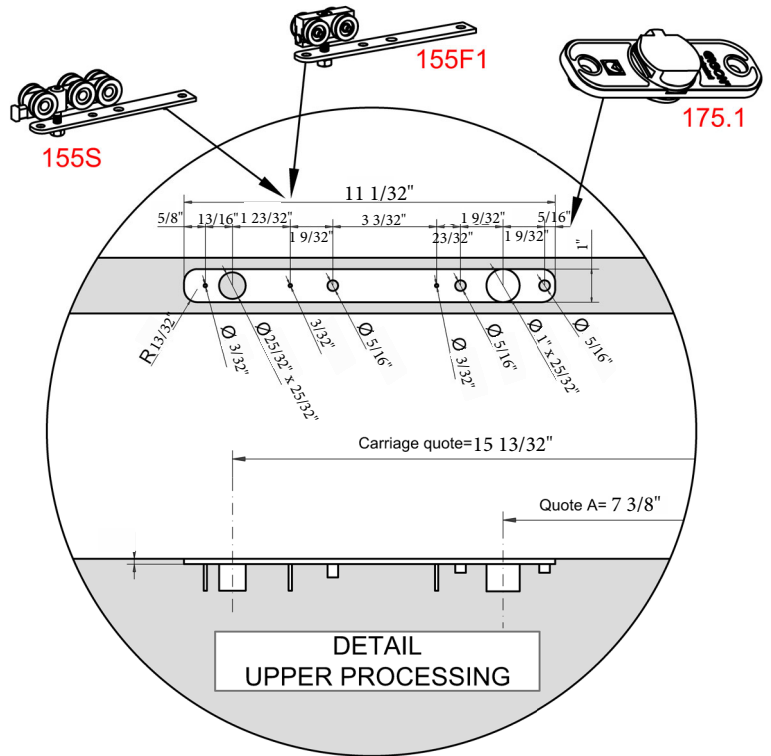
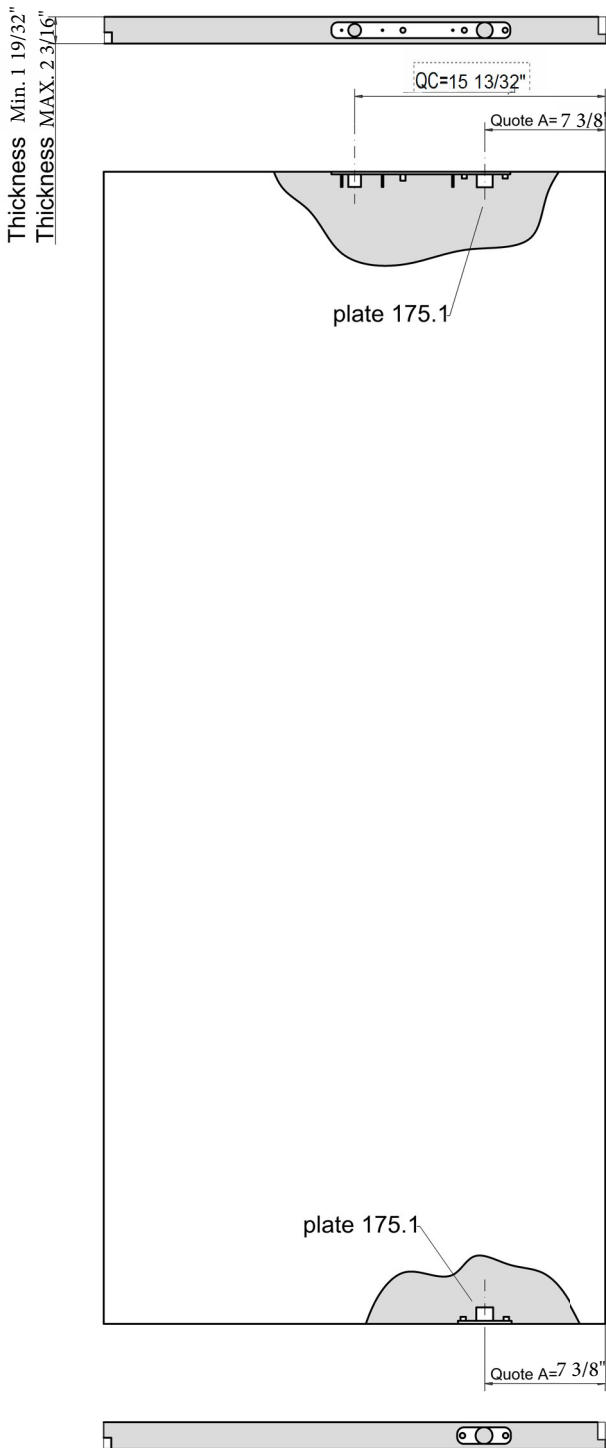

Example equipment "M"

155F2 and 155F3 PLATE PROCESSING SPECIFICATIONS

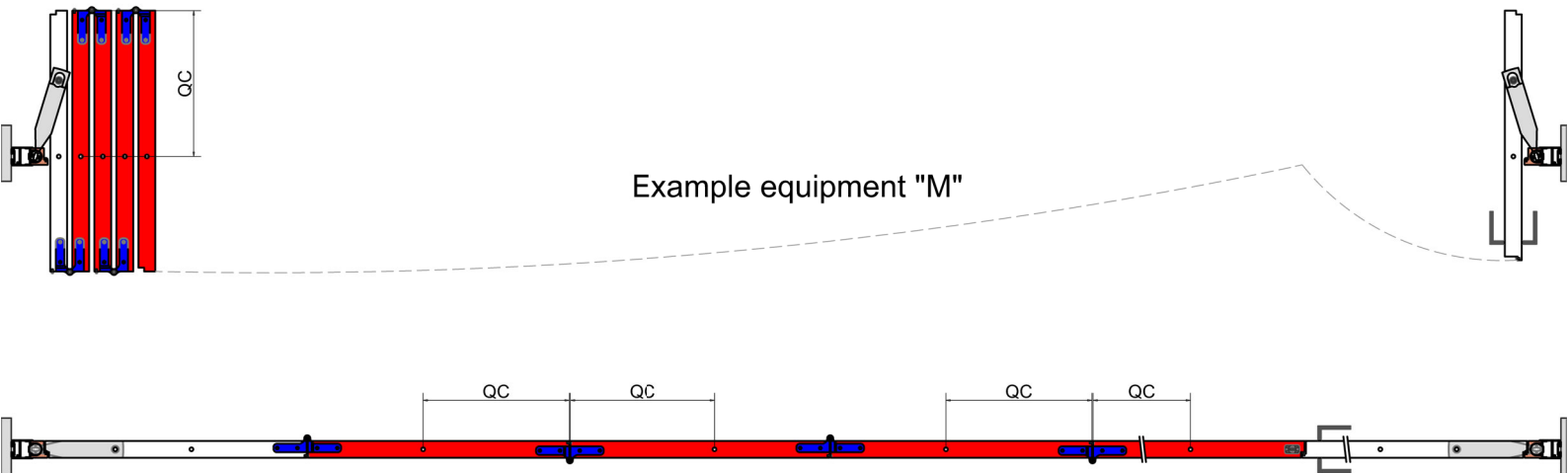
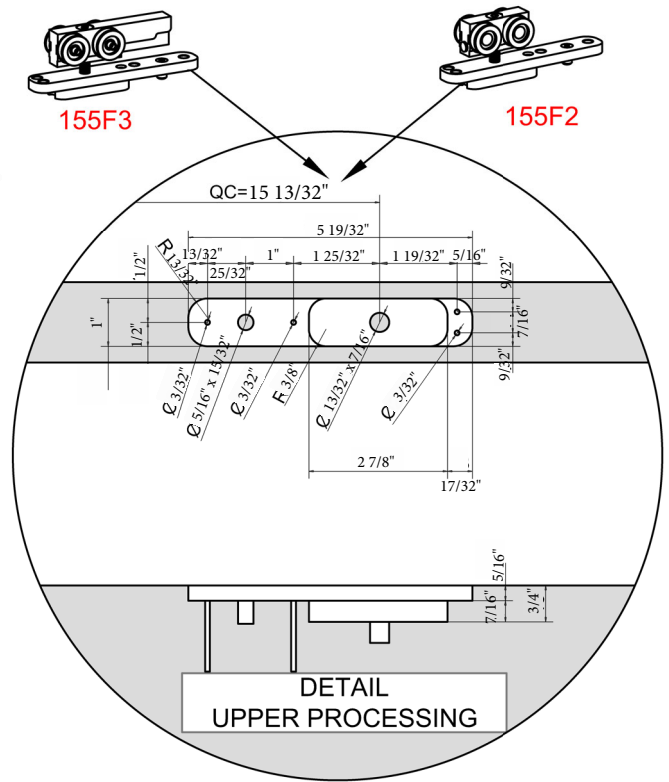
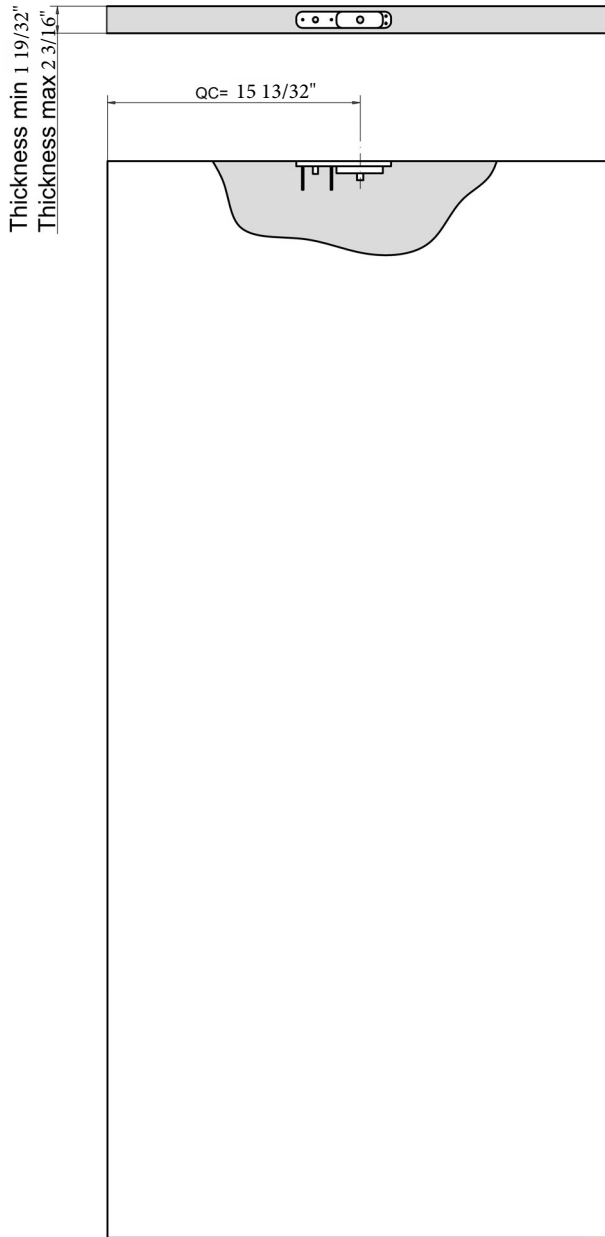

DOOR LEAF PROCESSING SPECIFICATIONS FOR THE GASKET

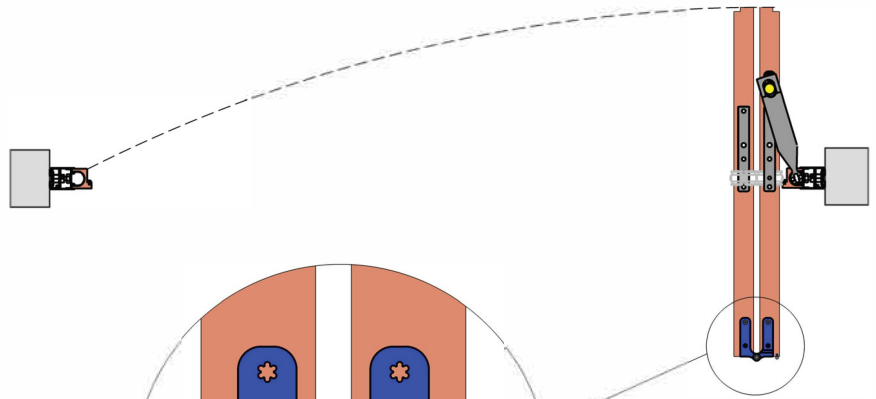

Detail on the door leaf processing

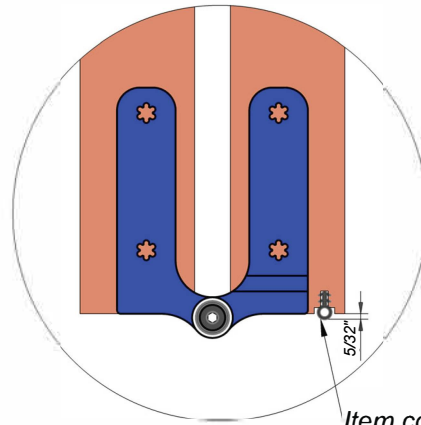
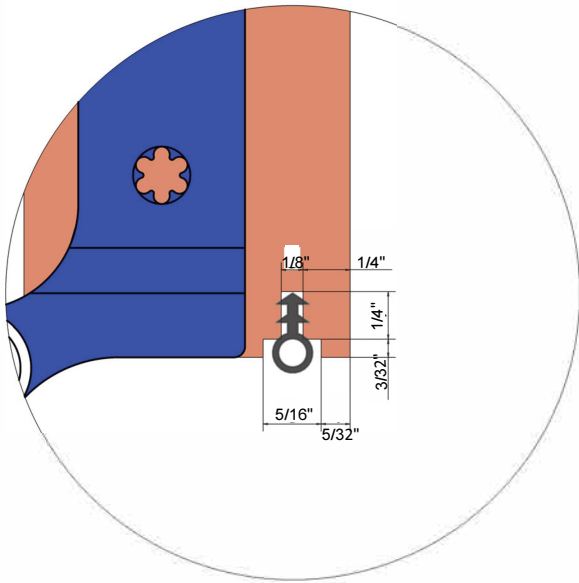

Item code gasket Roverplastik A 109 S 68

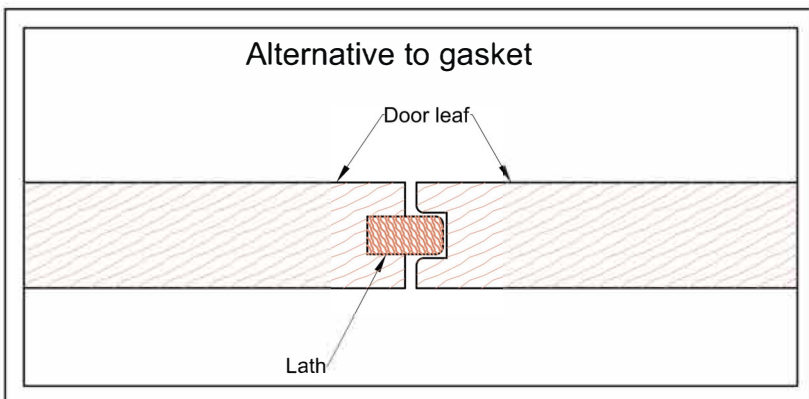
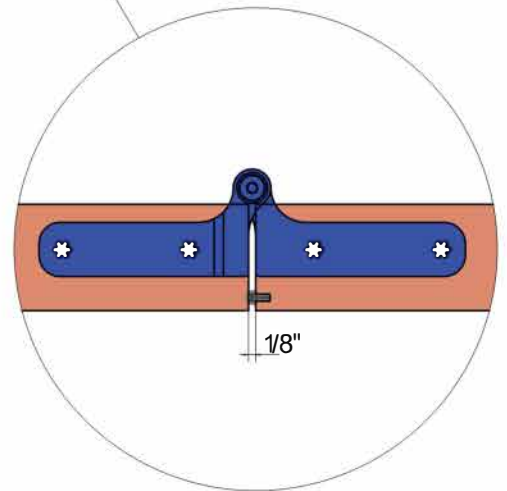
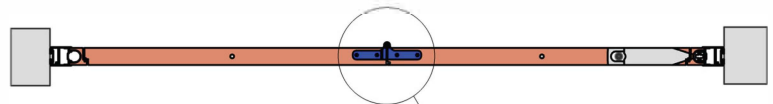

EXPLODED VIEW OF HINGES KIT

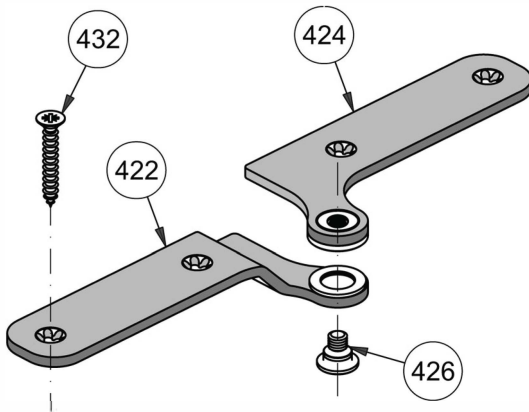

Hinge Right

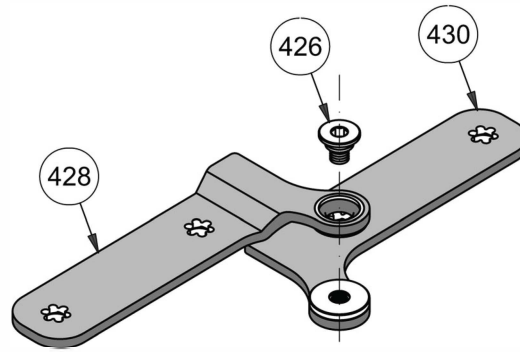

Hinge Left

Parts		
RIF.	Q.ty	Description
422	1	Right hinge curved element Right
424	1	hinge flat element Elements union
426	2	screw M5
428	1	Left hinge curved element
430	1	Left hinge flat element
432	8	Screw for wood TSPtorx Ø5/32"x1 3/16"

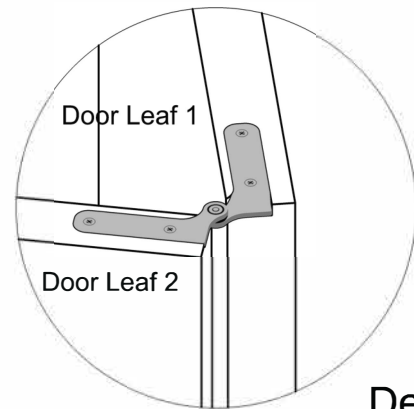
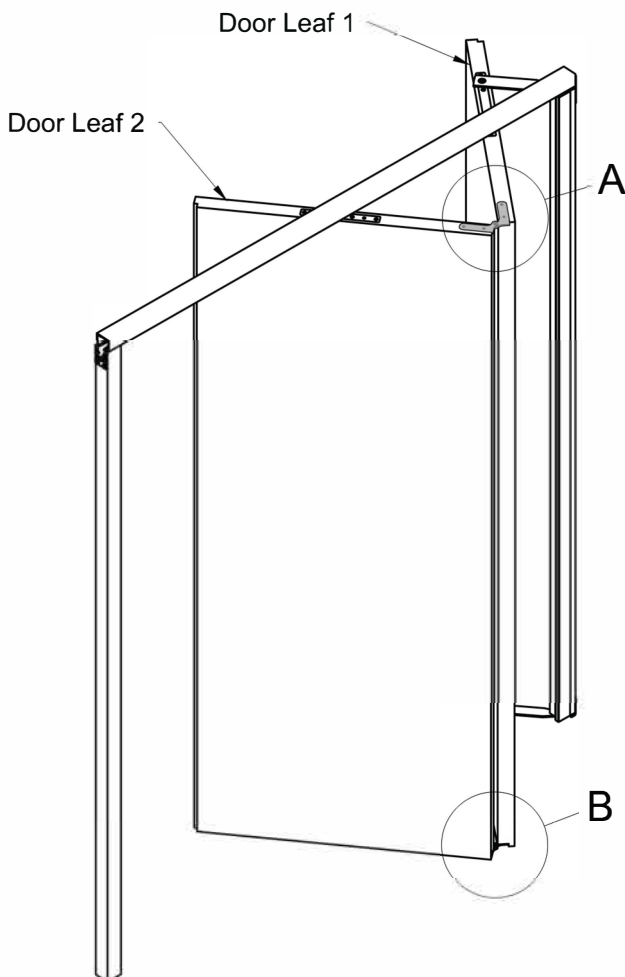

Detail A

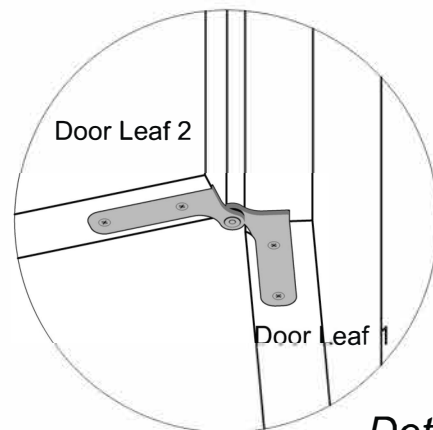

Detail B

POSITIONING HINGES

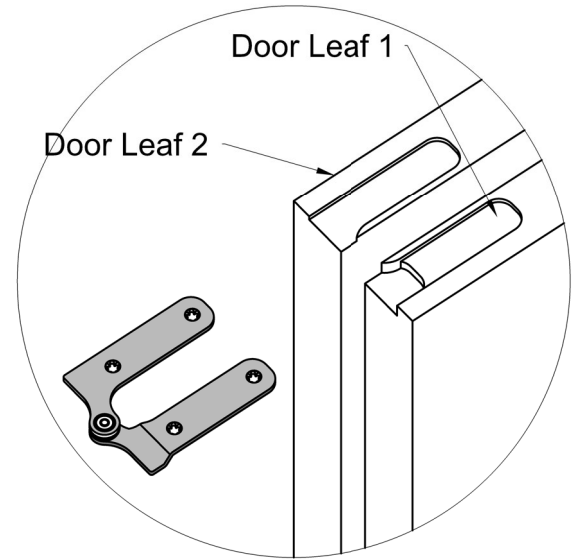
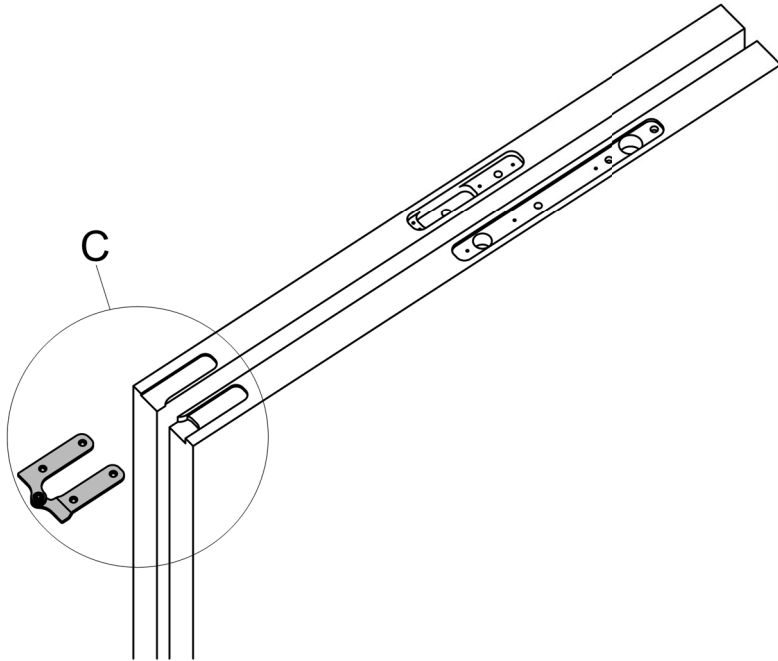

Detail C

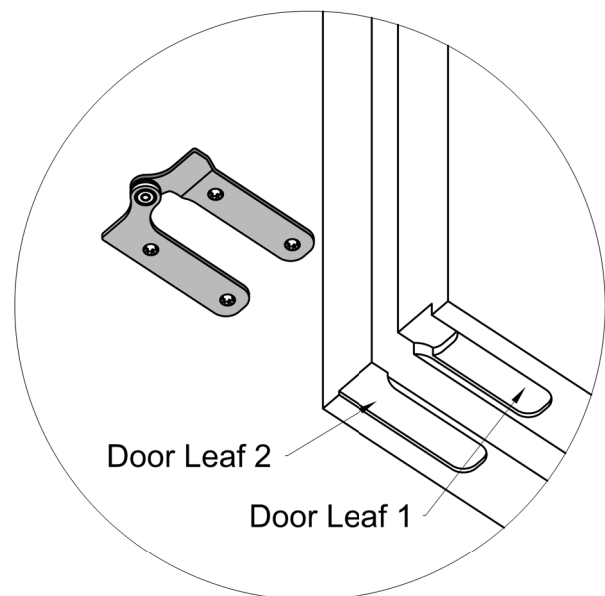
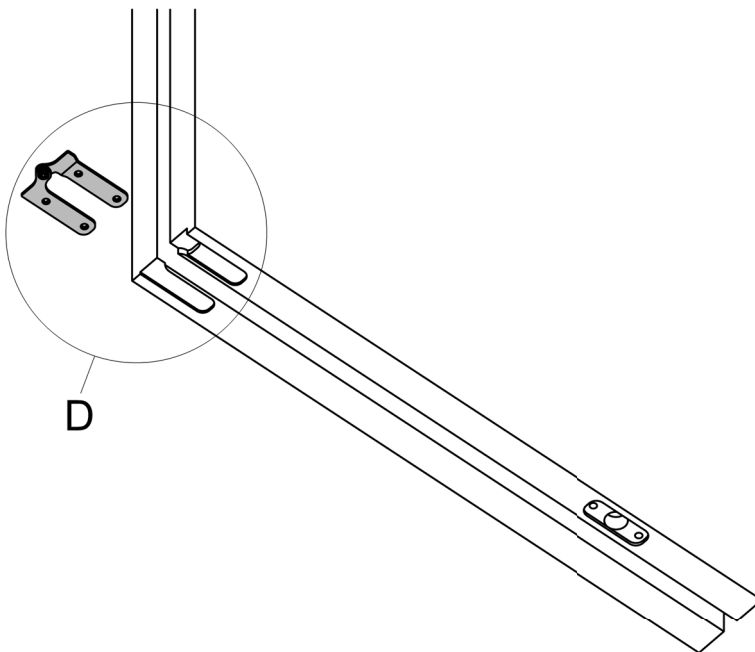

Detail D

DOOR LEAVES PROCESSING

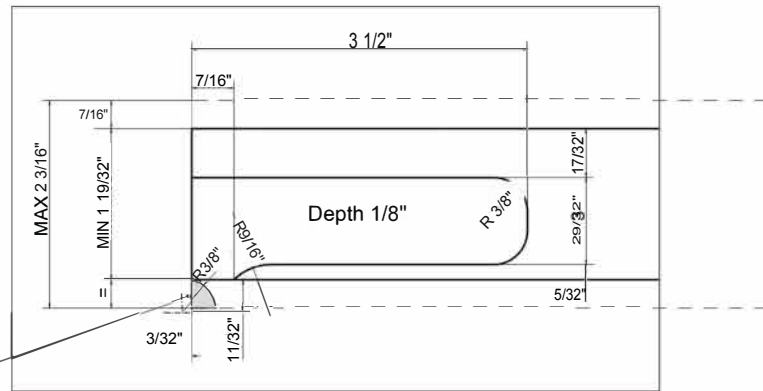

Milling to be done on door thicknesses bigger than 1 19/32"
Total depth 3/8"

Detail E

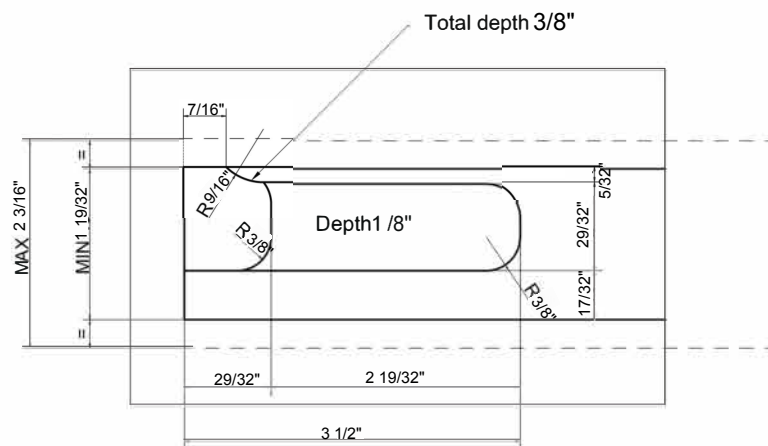
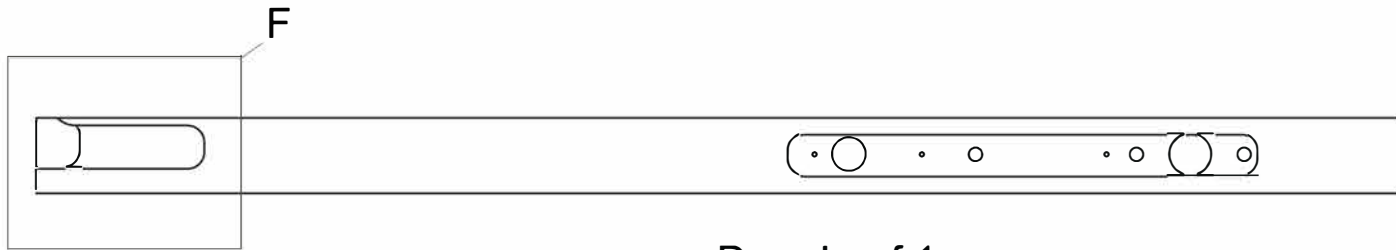
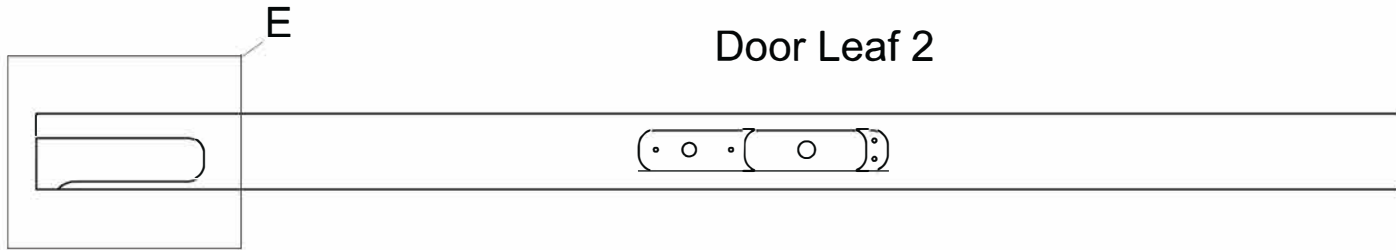

Detail F

HINGES ASSEMBLY

For door leaves with a thickness bigger than $1 \frac{31}{32}$ " , a processing must be carried out as shown in the drawing below, which is useful for inserting the screw (426)

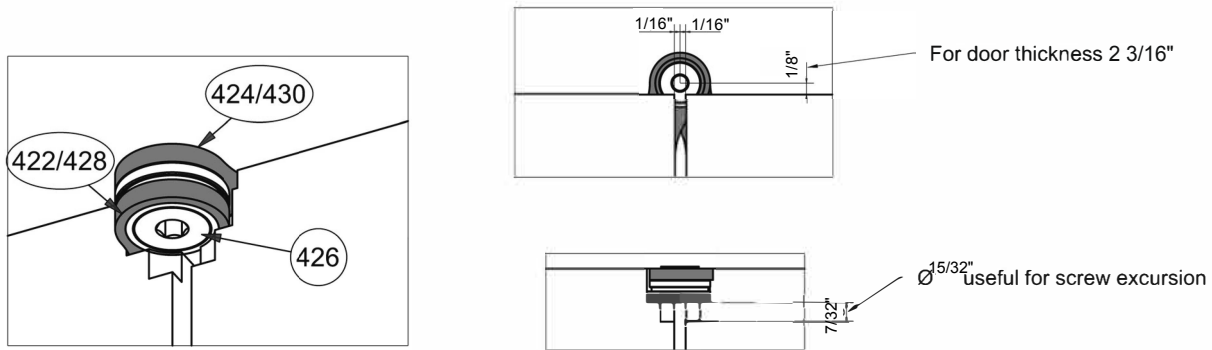

Separate the hinge by completely unscrewing the joining screw (426), fix the single elements on the top and on the bottom of the door leaves

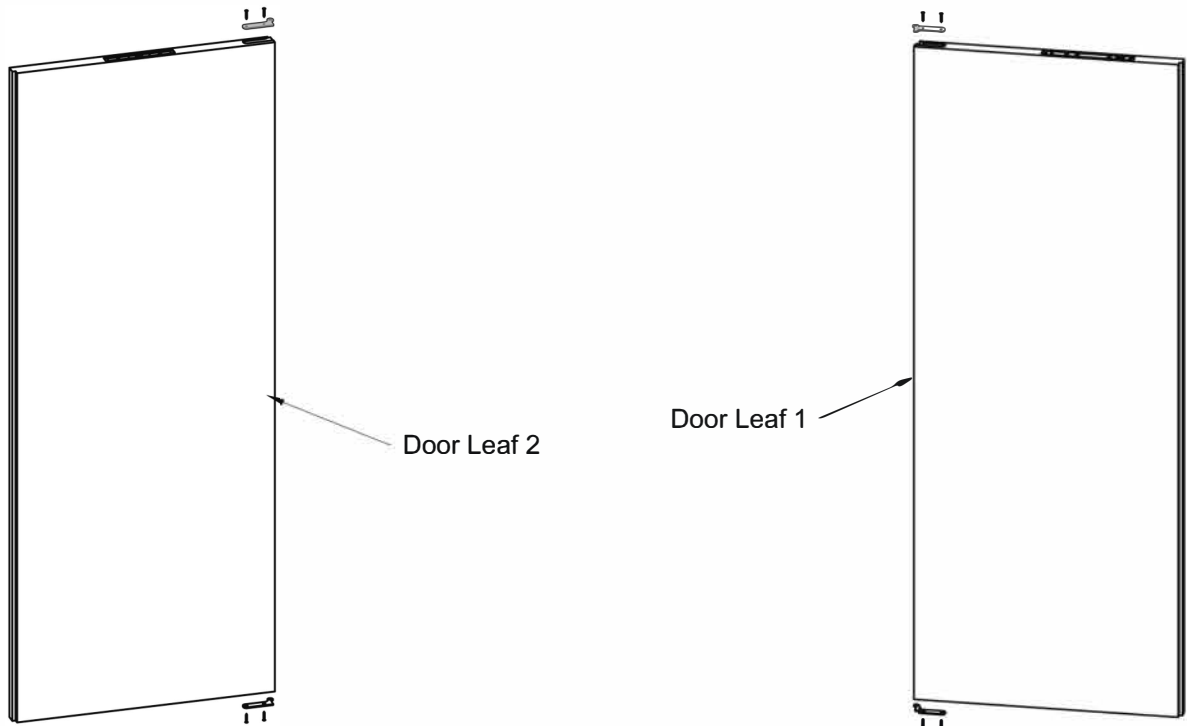

After hanging the doors on the track, put the doors together and join them using the joining screw (426), making sure that the brass bearing and the plastic washer are present



FOLDING DOOR LEAF LOCKING OPTIONS

Push&Go EVO (advised)

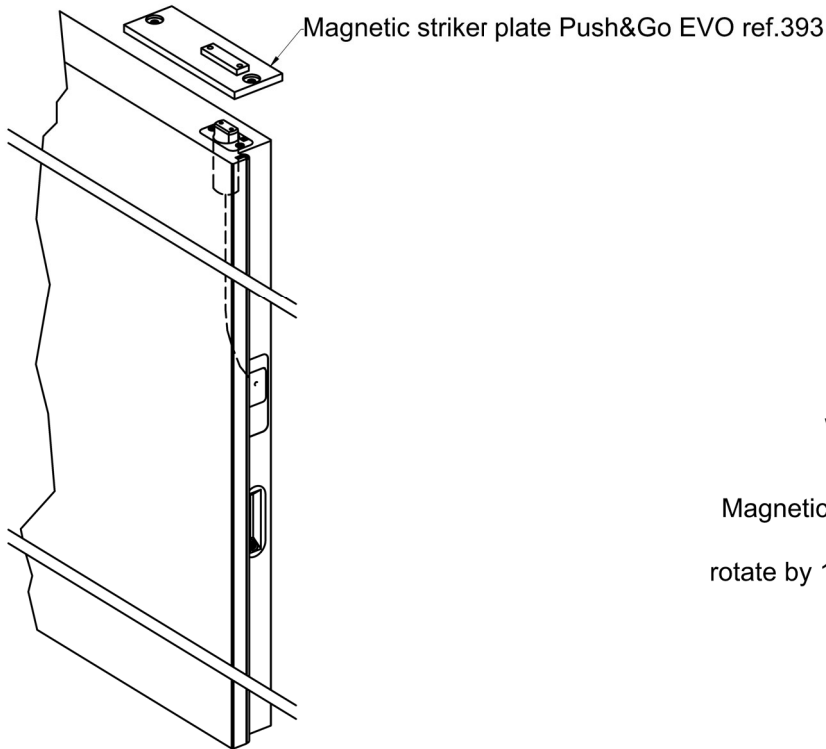

WITH BOLT

Magnetic striker plate Push&Go EVO ref.393 rotate by 180° and drill a hole for the bolt pin

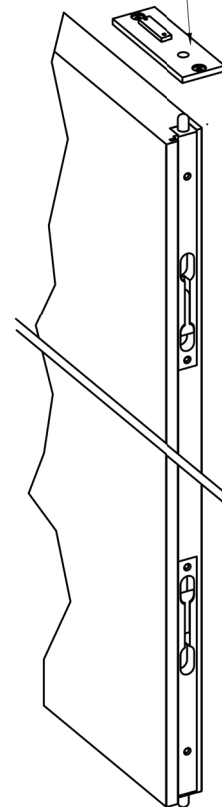

WITH LOCK FOR FOLDING DOORS

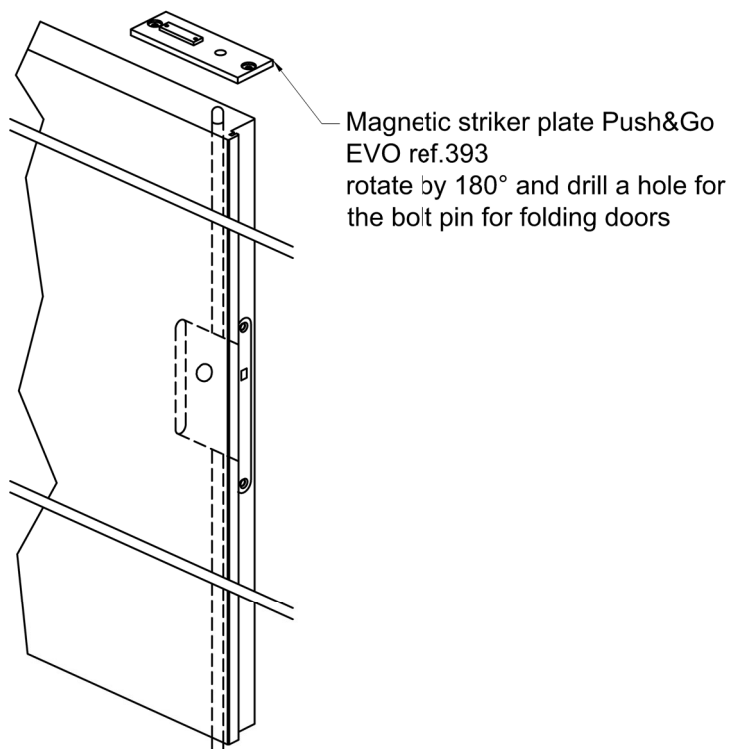

"SOFT OPENING S1" INSTALLATION

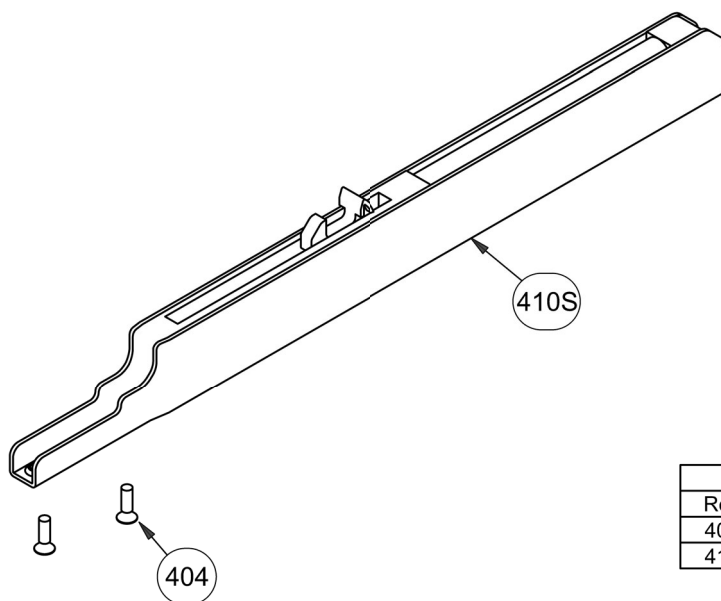

Parts list		
Ref.	Q.ty	Description
404	2	Screw TSP+ M3x8 - ISO 7046
410S	1	Soft Opening S1

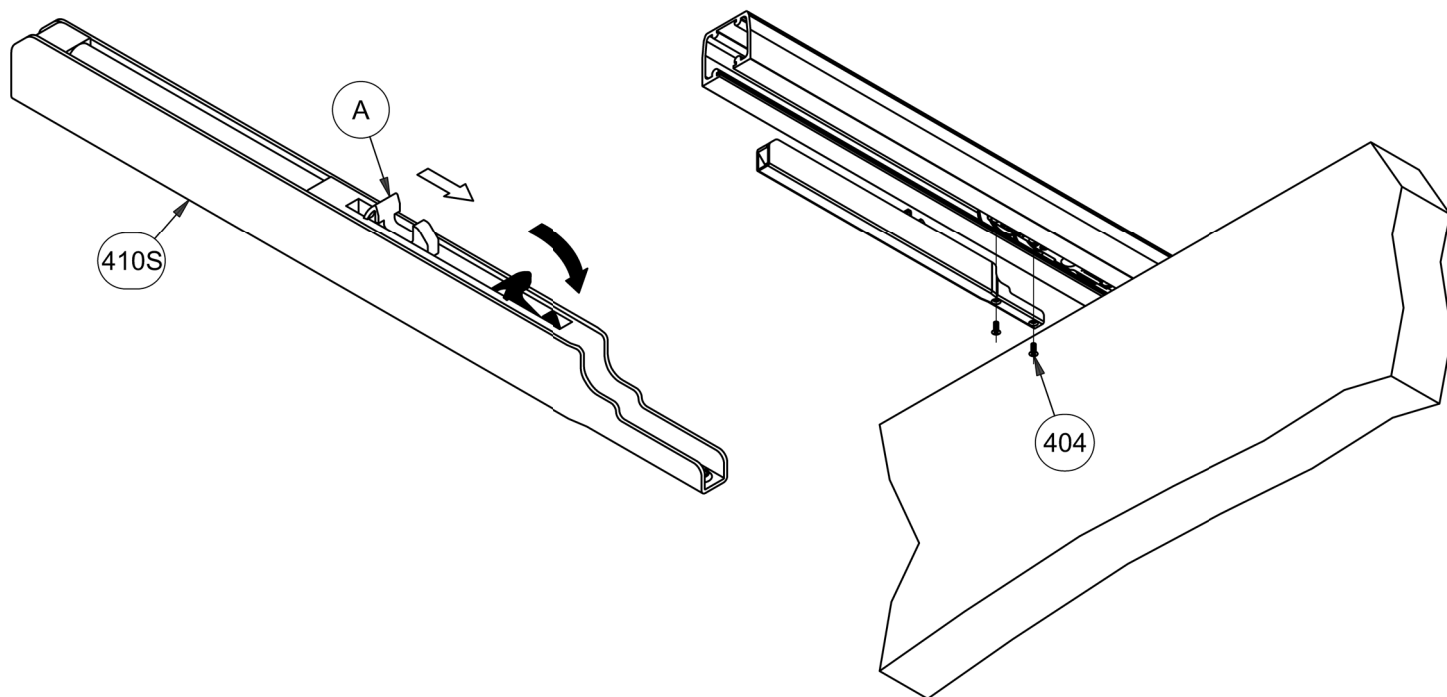

- 1) Push hook (A) to set the Soft Opening (410S).
Mount Soft Opening unit using the screw provided (404).
- 2) Verify that the Soft Opening system functions properly.
Finish installing door.

"SOFT OPENING PLUS" INSTALLATION

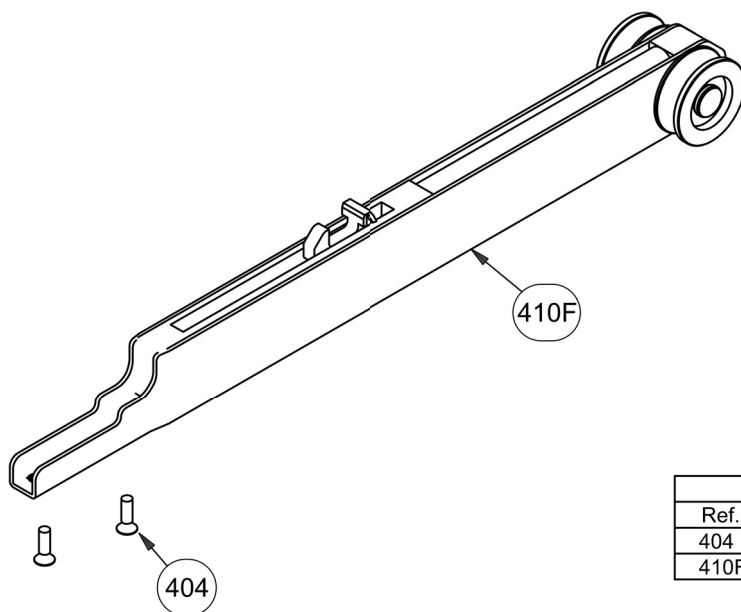

Parts list		
Ref.	Q.ty	Description
404	2	Screw TSP+ M3x8 - ISO 7046
410F	1	Soft Opening Plus

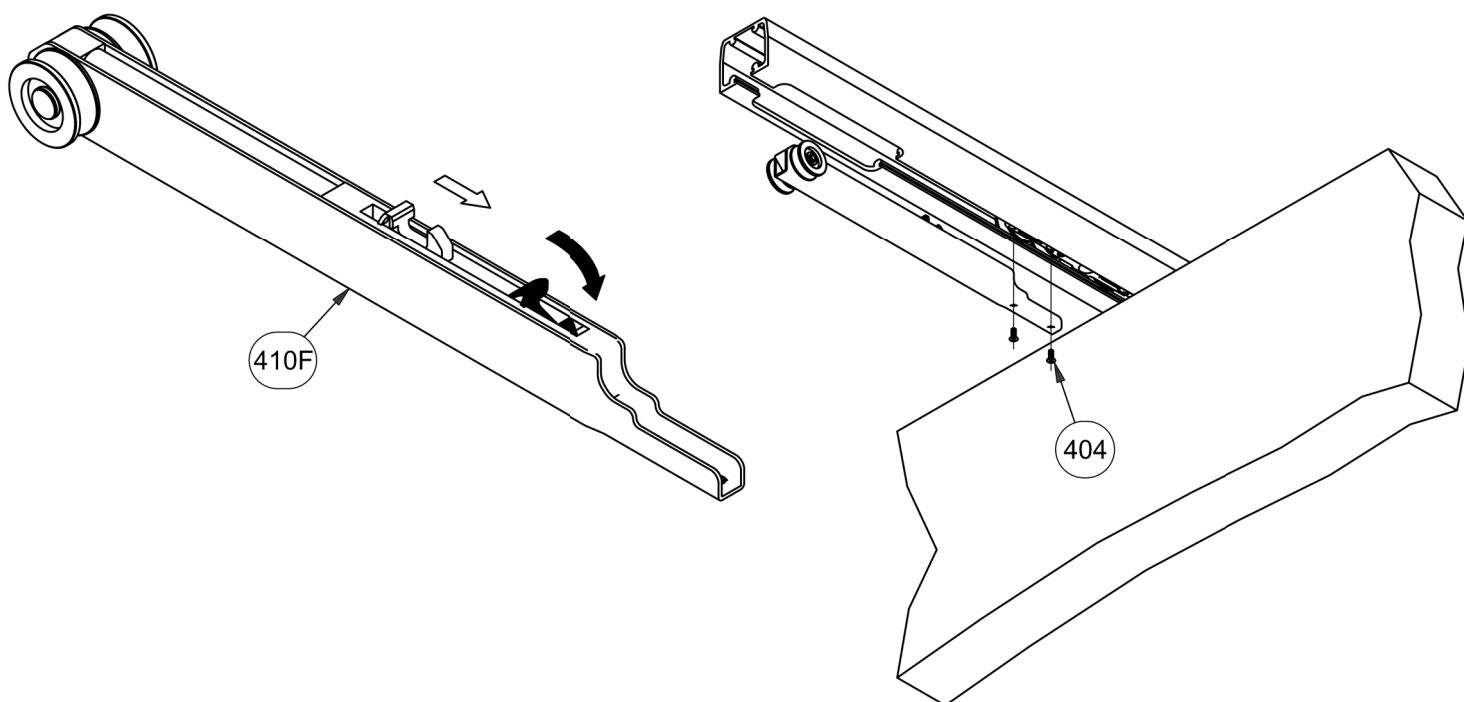

- 1) Push hook (A) to set the Soft Opening (410F).
Mount Soft Opening unit using the screw provided (404).
- 2) Verify that the Soft Opening system functions properly.
Finish installing door.



MILCASA STORE



2211 2nd Ave North, Suite A105
Lake Worth, FL 33461
(888) MILCASA (645-2272)

milcasastore.com | support@milcasastore.com