

# ERGON<sup>®</sup>

---

## LIVING

# FOLDING

**TECHNICAL MANUAL - CONSTRUCTION AND INSTALLATION**  
Swinging sliding Folding pivot door with adjustable external frame  
Up to 6 door leaves

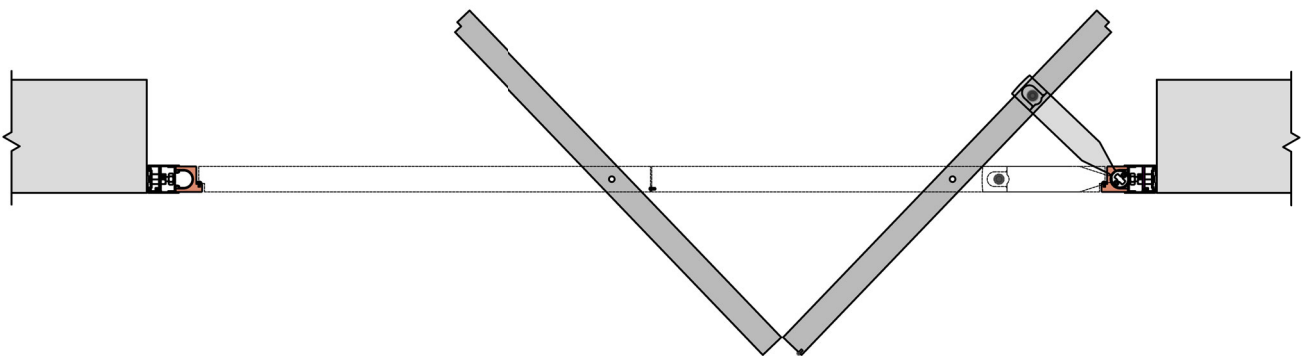

INDEX

Introduction	pag. 3
Parts list	pag. 4
Accessories	pag. 5
Equipments	pag. 6
Horizontal sections	pag. 7
Legend for dimensional drawings	pag. 8
Horizontal dimensional drawings - equipments with 2 doors leaf	pag. 8
Horizontal dimensional drawings - equipments with 3 doors leaf	pag. 9
Horizontal dimensional drawings - equipments with 4 doors leaf	pag. 10
Horizontal dimensional drawings - equipments with 5 doors leaf	pag. 11
Horizontal dimensional drawings - equipments with 6 doors leaf	pag. 12
Vertical ceiling sections	pag. 13
Ceiling vertical dimensional drawings	pag. 14
Vertical section on false ceiling	pag. 15
Vertical dimensional drawings on false ceiling	pag. 16
Working position according to the equipments "A; D; H; L"	pag. 17
Working position according to the equipments "B; E; I; M"	pag. 18
Working position according to the equipments "C; F; G"	pag. 19
Plate processing specification 155S e 155F1	pag. 20
Plate processing specification 155F2 e 155F3	pag. 21
Specifications of door leaf processing for gasket	pag. 22
Folding hinge kit exploded view (optional)	pag. 23
Folding hinge positioning (optional)	pag. 24
Workings doors leaf for Folding hinges (optional)	pag. 25
Folding hinge assembly (optional)	pag. 26
Folding door leaf locking options	pag. 27
"Soft Opening S1" installation	pag. 28
"Soft Opening Plus" installation	pag. 29



## INTRODUCTION

Ergon Living FOLDING is an evolution of the Ergon Living T.E. system, it allows the rototranslating movement of several door leaves connected to each other by moving only the outermost door leaf, it has no floor guides and the movement is fluid and stable.

The system features an aluminum frame equipped with special adjustments to ensure correct installation

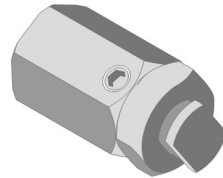

Patent pending









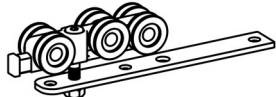
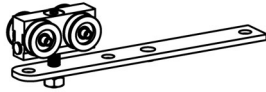
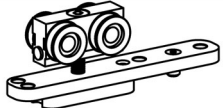
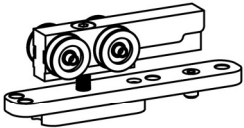

### TECHNICAL FEATURES:

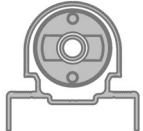

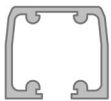
- Door leaf thickness from 40 to 55 mm
- Single leaf weight limit: 70Kg
- Weight limit for folding door leaves: 50kg per door leaf
- Can be installed directly on the ceiling (see page 5) or on a false ceiling (see page 6)

DOWNLOAD ON [www.celegon.it](http://www.celegon.it):



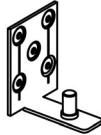
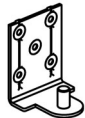
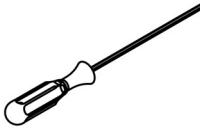

- Calculator for developing measurements and fittings: enter the wall opening width and height measurements, enter with or without false ceiling, select the desired fitting.
- Video animation for the correct installation of the whole system.

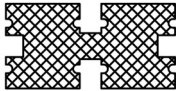
**PARTS LIST**

	Carriage for single door leaf <b>Rif. 155S</b>
	Carriage for 1^ folding door leaf <b>Rif. 155F1</b>
	Carriage for folding door leaves with adjustable plate <b>Rif. 155F2</b>
	Carriage for folding door leaves adjustable with plate and Soft Opening <b>Rif. 155F3</b>
	Upper and lower arm <b>Rif. 185F</b>
	Arm cap <b>Rif. 186F</b>
	Rod cover upright profile (with or without rod)
	External frame profile
	External frame profile cover
	Track profile <b>Rif. 100F</b>
	Track cover profile <b>Rif. 145F</b>
	Upper and lower arm plate <b>Rif. 175.1</b>
	Outer frame alignment plug <b>Rif. 426F</b>
	Clips for hooking the veil profile on external frame profile <b>Rif. 397F</b>
	Track cover fixing pin <b>Rif. 250F</b>

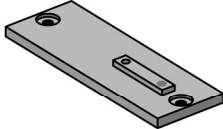
	Upper bracket <b>Rif. 130F</b>
	Lower bracket <b>Rif. 195</b>
	Hex screwdriver 2,5mm <b>Rif. 280</b>
	Double 3 mm hex key for Folding carriage adjustment <b>Rif. 405F</b>
	Special hex key 7mm for adjustable carriage <b>Rif. 415F</b>
	Sponge cleaner for track <b>Rif. 420</b>

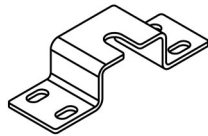
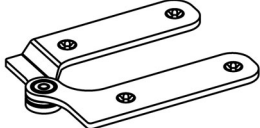
**ACCESSORIES**

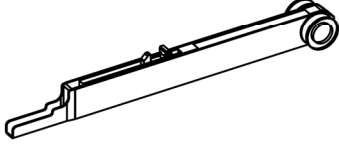
	Push&Go EVO striker plate <b>Rif. 393</b> See p. 27
	Plate with threaded bar for false ceiling system <b>Rif. 422F</b>
	Omega plate for false ceiling system <b>Rif. 424F</b>
	Folding hinge (optional)
	Soft Opening S1 single leaf (optional) <b>Rif. 410S</b>
	Soft Opening Plus with folding door bearings (optional) <b>Rif. 410F</b>

**ACCESSORIES**

- FOLDING HINGES: assemblable and specially designed for the Folding system -

Item code:

C701000F1 BLACK

C721000F1 STAINLESS

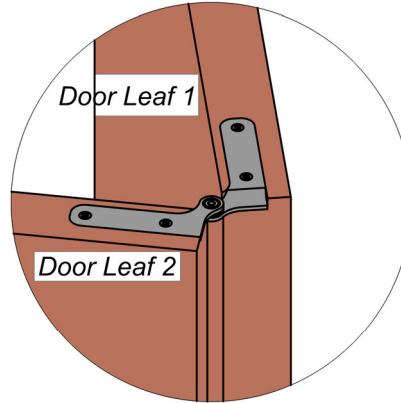

- SOFT OPENING S1: damper for single door leaf

- SOFT OPENING PLUS: damper for Folding door leaves

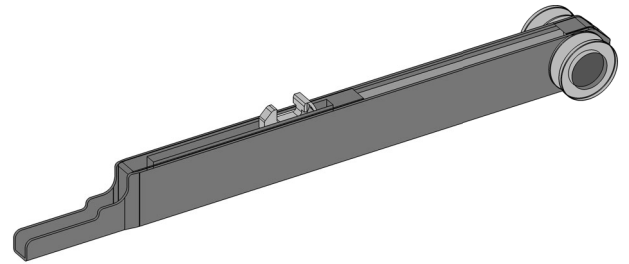
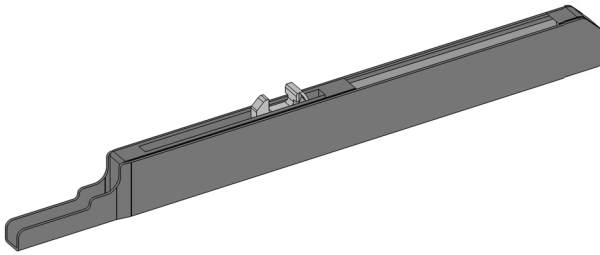

- BALLOON GASKET Ø6,8 mm: see pag. 21 "leaf processing specifications for gasket"

Item code:

GS680--- (see price list)

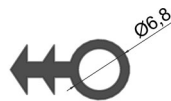

- Push&Go EVO: Quick release system for Folding door leaves

Item code Push:

4100-- (see price list)

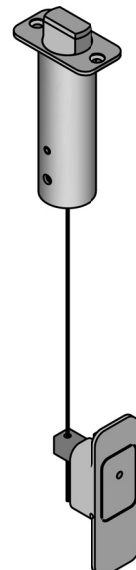
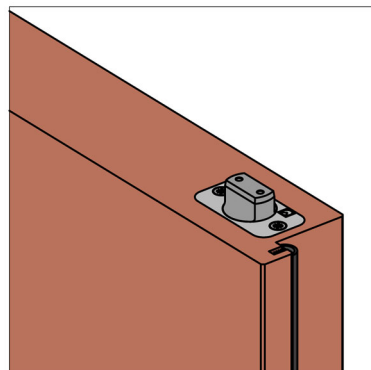

**EQUIPMENTS**

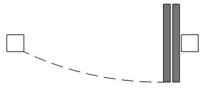

**Equipment "A"**

Single folding opening with 2 door leaves  
Wall Hole Width: **Minimum 1245 - Max 2585**



**Equipment "B"**

Double opening: single + folding with 2 door leaves  
Wall Hole Width: **Minimum 1910 - Max 3780**

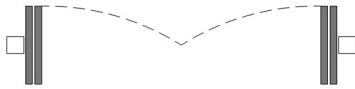

**Equipment "C"**

Double folding opening with 2 door leaves  
Wall Hole Width: **Minimum 2300 - Max 4980**



**Equipment "D"**

Single folding opening with 3 door leaves  
Wall Hole Width: **Minimum 1990 - Max 3790**



**Equipment "E"**

Double opening: single + folding with 3 door leaves  
Wall Hole Width: **Minimum 2530 - Max 4980**



**Equipment "F"**

Double opening: folding with 2 doors + folding with 3 door leaves  
Wall Hole Width: **Minimum 2925 - Max 6185**

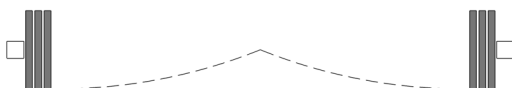

**Equipment "G"**

Double opening: single + folding with 3 door leaves  
Wall Hole Width: **Minimum 3550 - Max 6550**



**Equipment "H"**

Single folding opening with 3 door leaves  
Wall Hole Width: **Minimum 2310 - Max 4990**

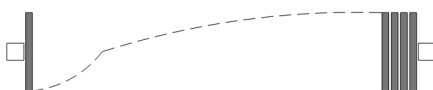

**Equipment "I"**

Double opening: single + folding with 4 door leaves  
Wall Hole Width: **Minimum 2975 - Max 6185**



**Equipment "L"**

Single folding opening with 5 door leaves  
Wall Hole Width: **Minimum 3195 - Max 6195**



**Equipment "M"**

Double opening: single + folding with 5 door leaves  
Wall Hole Width: **Minimum 3660 - Max 6550**

Use the calculator to get all the measurements you need  
For other setups, ask Celegon S.r.l. for feasibility.

HORIZONTAL SECTIONS

Horizontal section applied to the stile

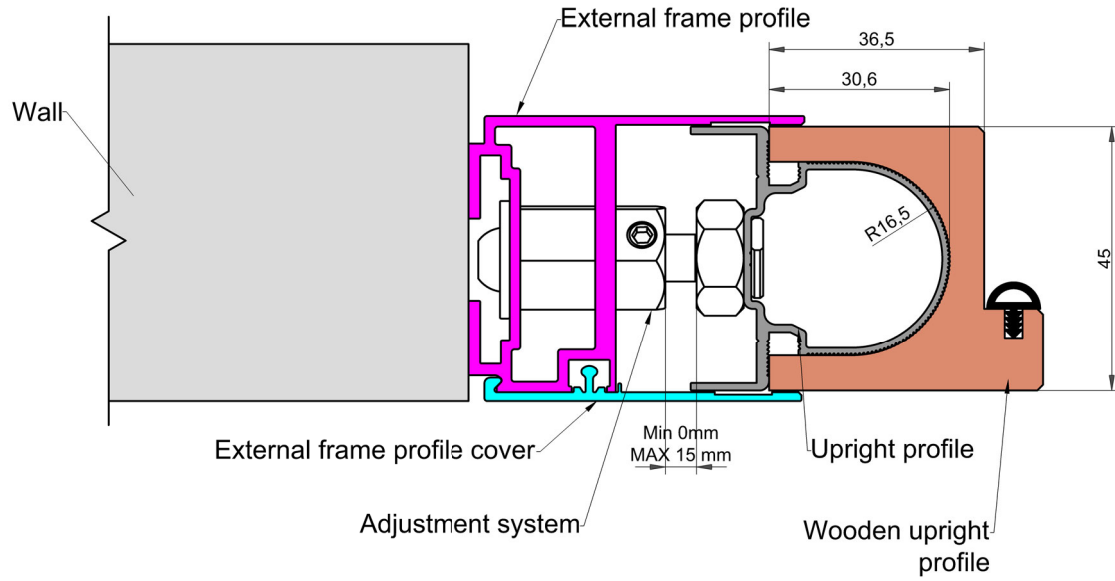

Horizontal section applied to the wall

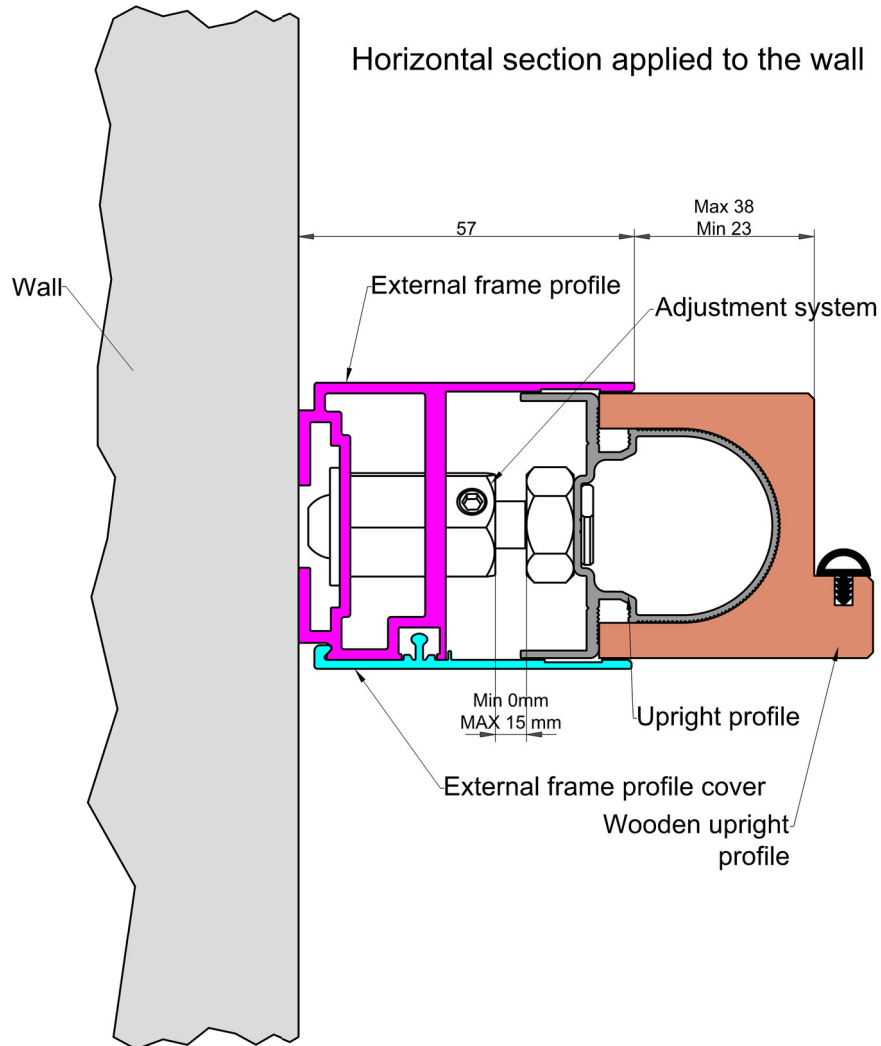

**LEGEND FOR DIMENSIONAL DRAWINGS**

- LFM** = WALL HOLE WIDTH
- LP** = PASSAGE DIMENSION
- LPD** = DOUBLE PASSAGE DIMENSION
- LS** = DOOR JAMB OPENING
- LA1** = SINGLE DOOR WIDTH
- LA2** = DOOR WIDTH WITH TWO CONSECUTIVE DOOR LEAVES
- LA3** = DOOR WIDTH WITH THREE CONSECUTIVE DOOR LEAVES
- LA4** = DOOR WIDTH WITH FOUR CONSECUTIVE DOOR LEAVES
- LA5** = DOOR WIDTH WITH FIVE CONSECUTIVE DOOR LEAVES
- QF = QC** = FIXED DIMENSION ENCUMBRANCE ARM-SIDE = CARRIAGE DIMENSION (391,3)
- QV** = VARIABLE DIMENSION ENCUMBRANCE HANDLE-SIDE
- HP** = PASSAGE HEIGHT DIMENSION
- HA** = DOOR LEAF HEIGHT
- HFM** = WALL HOLE HEIGHT
- HC** = FALSE CEILING HEIGHT

**HORIZONTAL DIMENSIONAL DRAWINGS - EQUIPMENTS WITH 2 DOOR LEAVES**

**EQUIPMENT "A"**

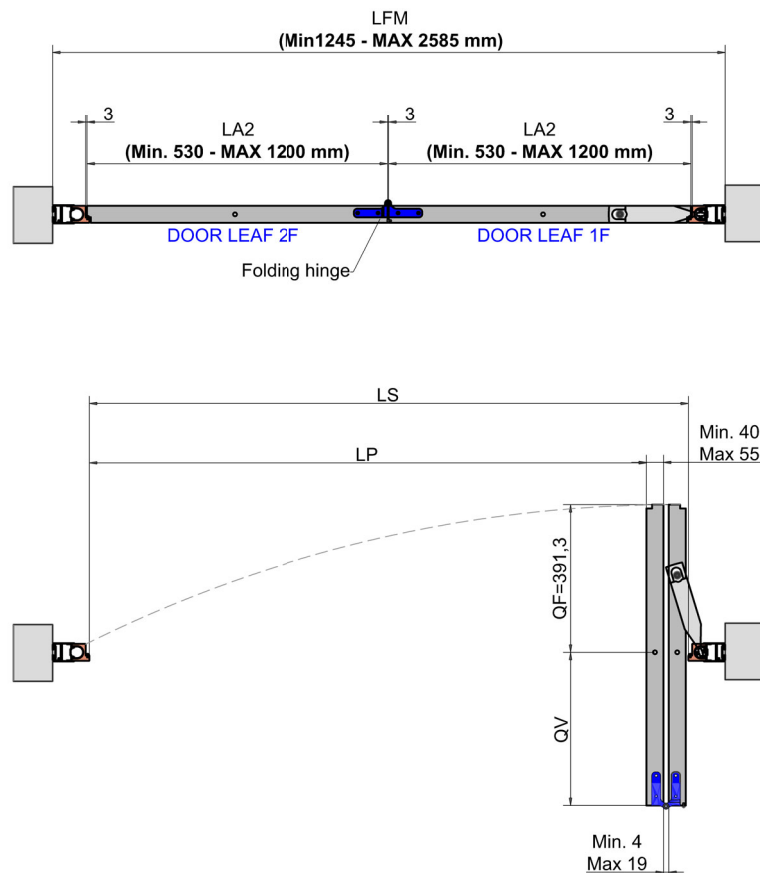



**HORIZONTAL DIMENSIONAL DRAWINGS - EQUIPMENTS WITH 3 DOOR LEAVES**

**EQUIPMENT "B"**

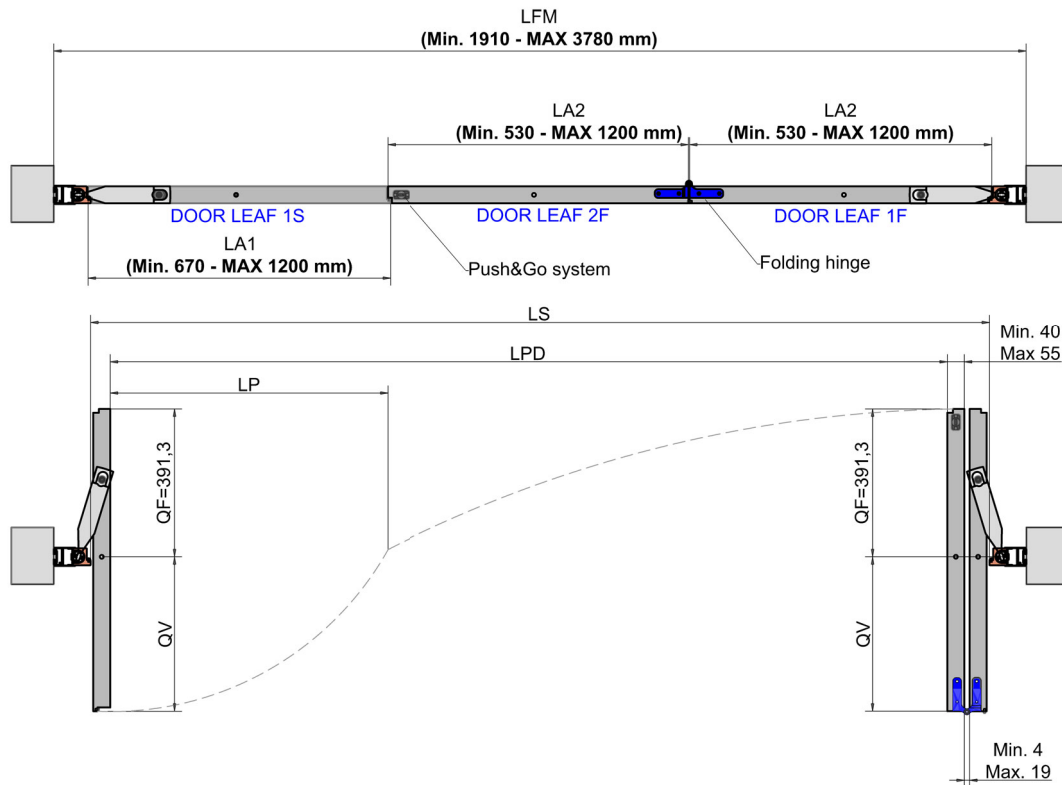

**EQUIPMENT "D"**

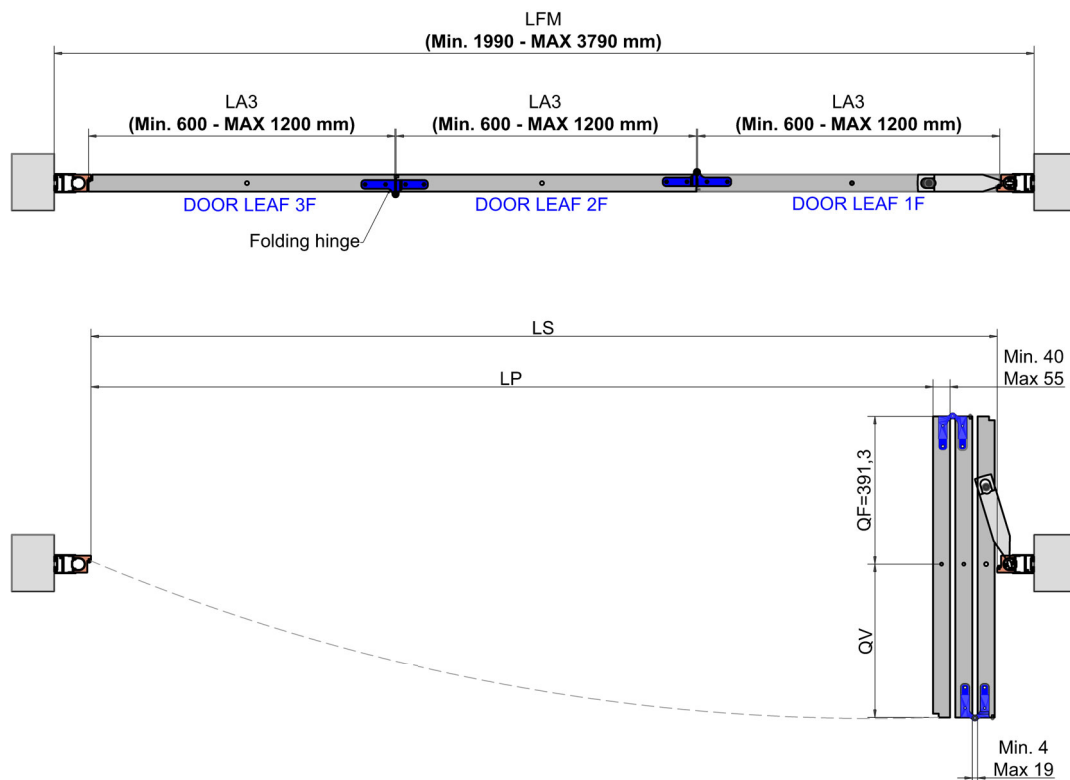

**HORIZONTAL DIMENSIONAL DRAWINGS - EQUIPMENTS WITH 4 DOOR LEAVES**

**EQUIPMENT "C"**

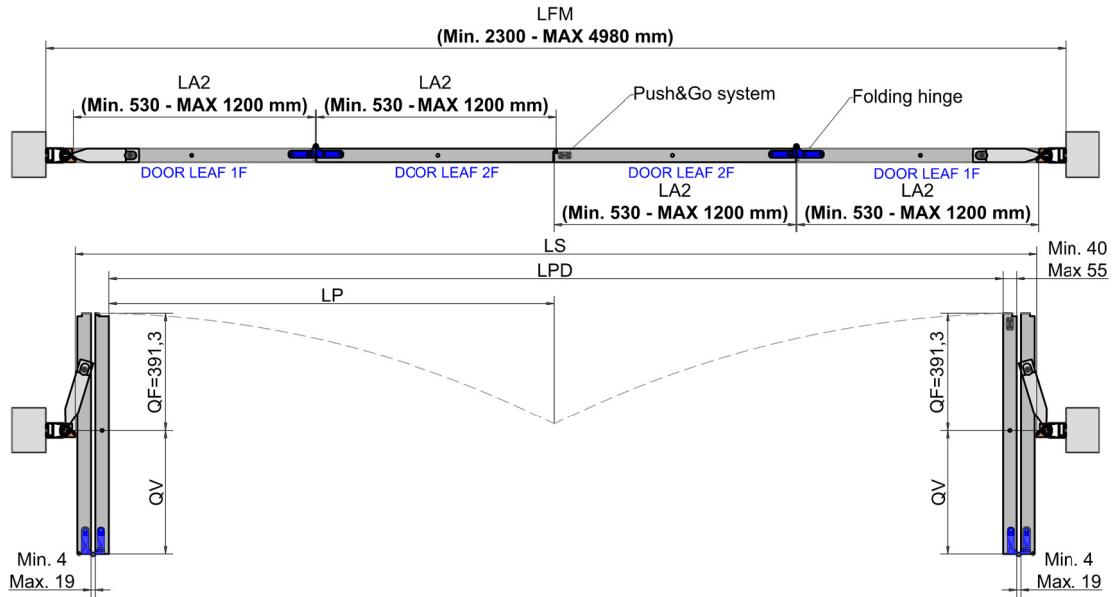

**EQUIPMENT "E"**

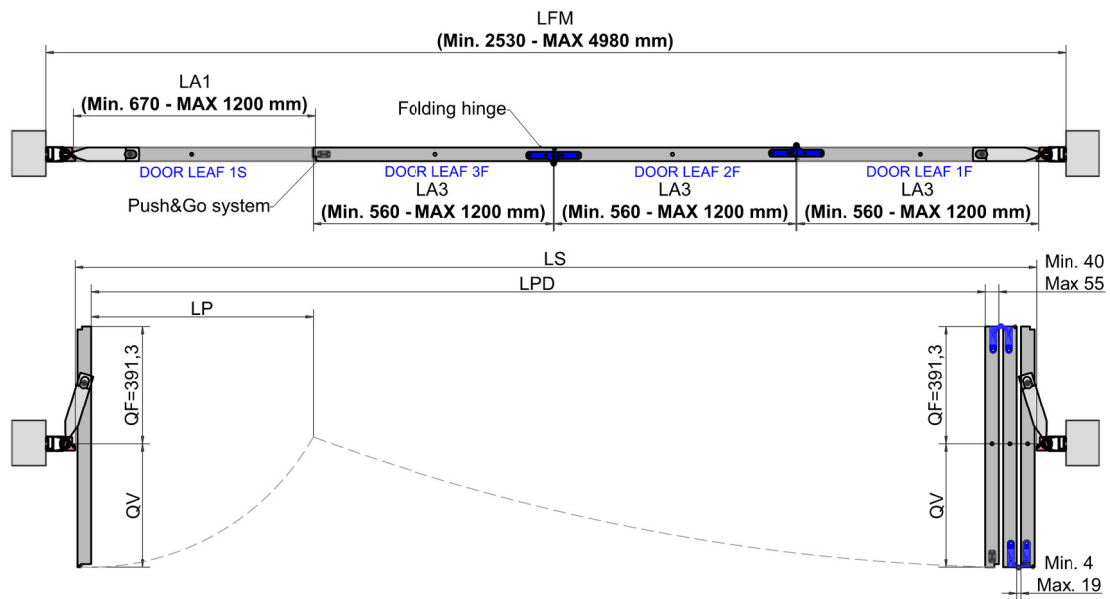

**EQUIPMENT "H"**

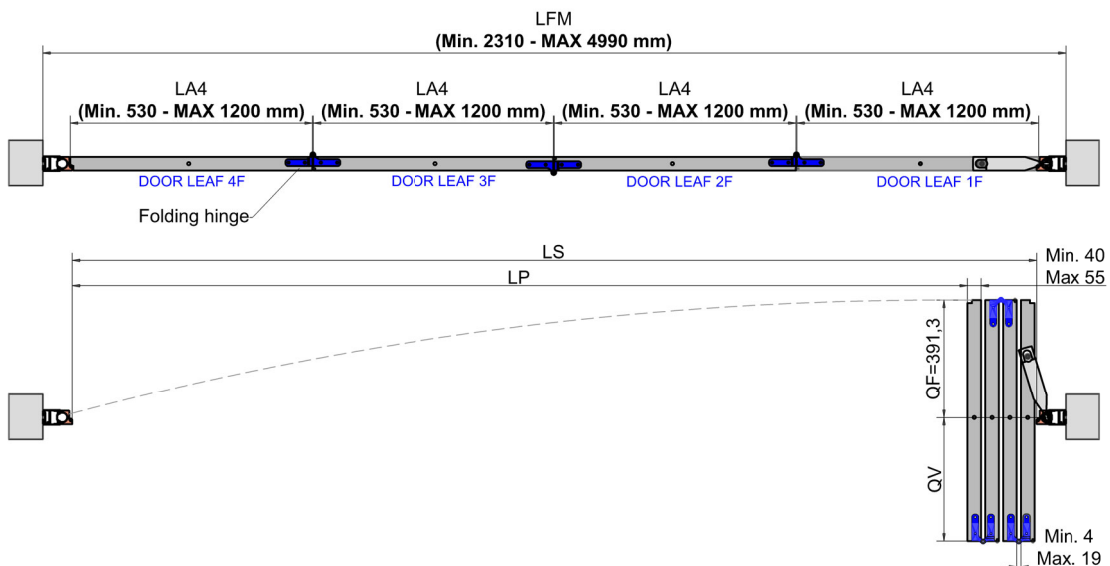

**HORIZONTAL DIMENSIONAL DRAWINGS - EQUIPMENTS WITH 5 DOOR LEAVES**

**EQUIPMENT "F"**

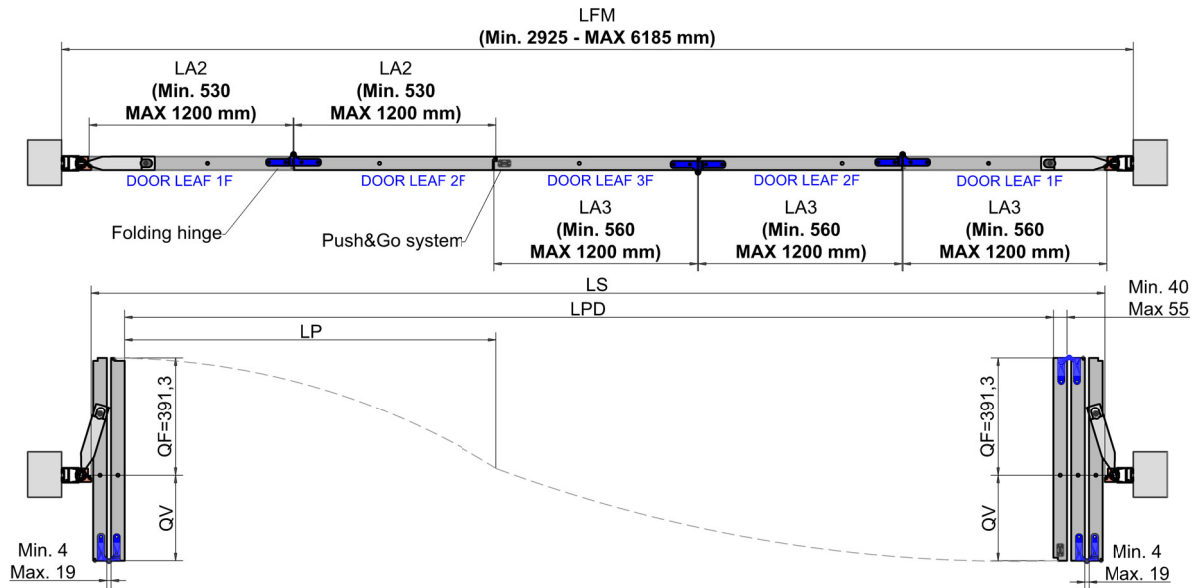

**EQUIPMENT "I"**

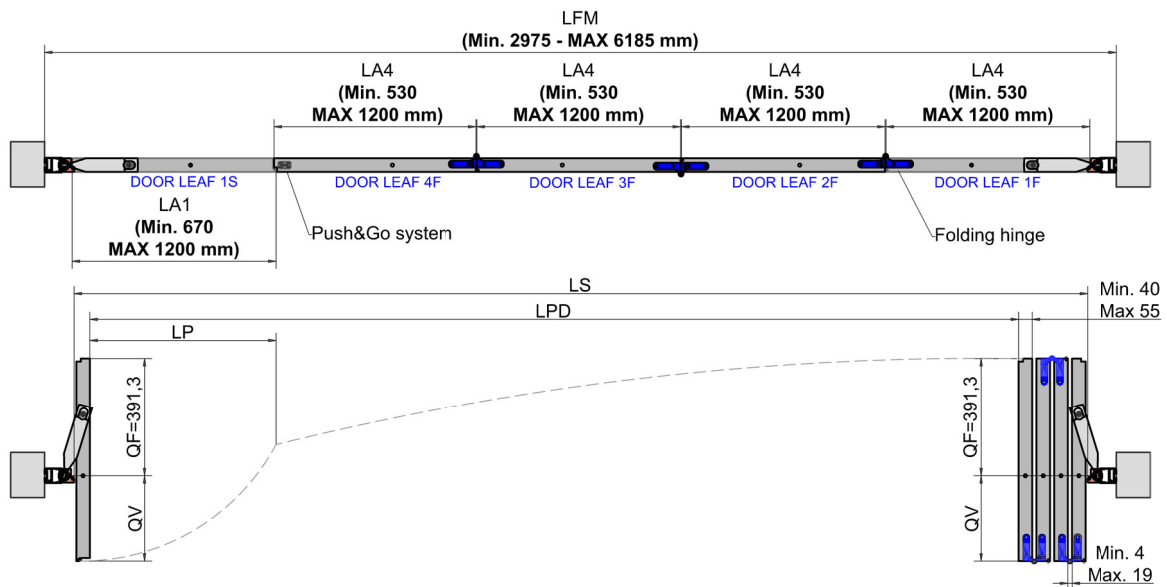

**EQUIPMENT "L"**

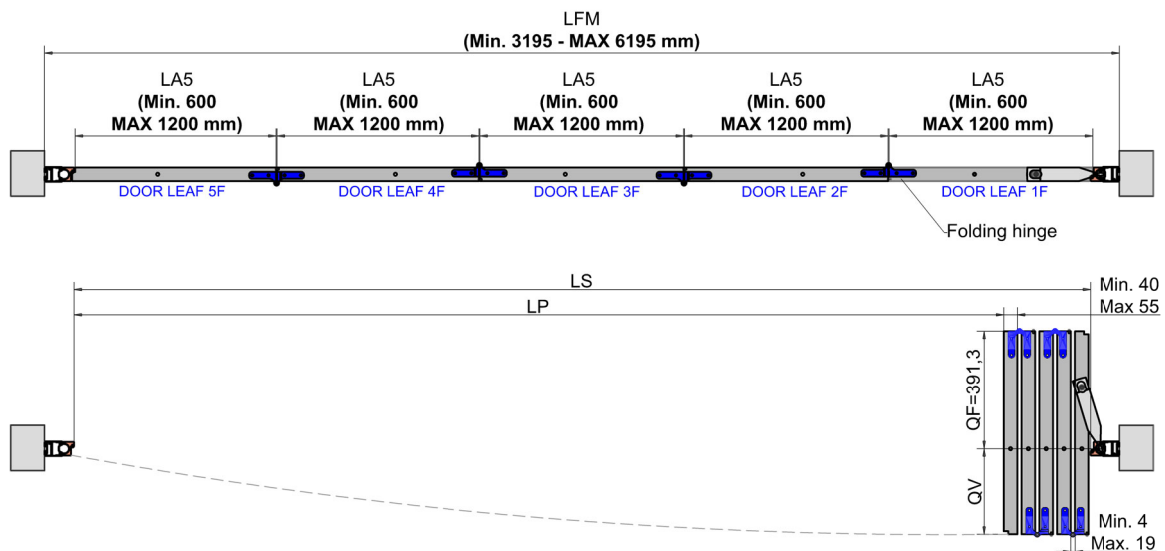

**HORIZONTAL DIMENSIONAL DRAWINGS - EQUIPMENTS WITH 6 DOOR LEAVES**

**EQUIPMENT "G"**

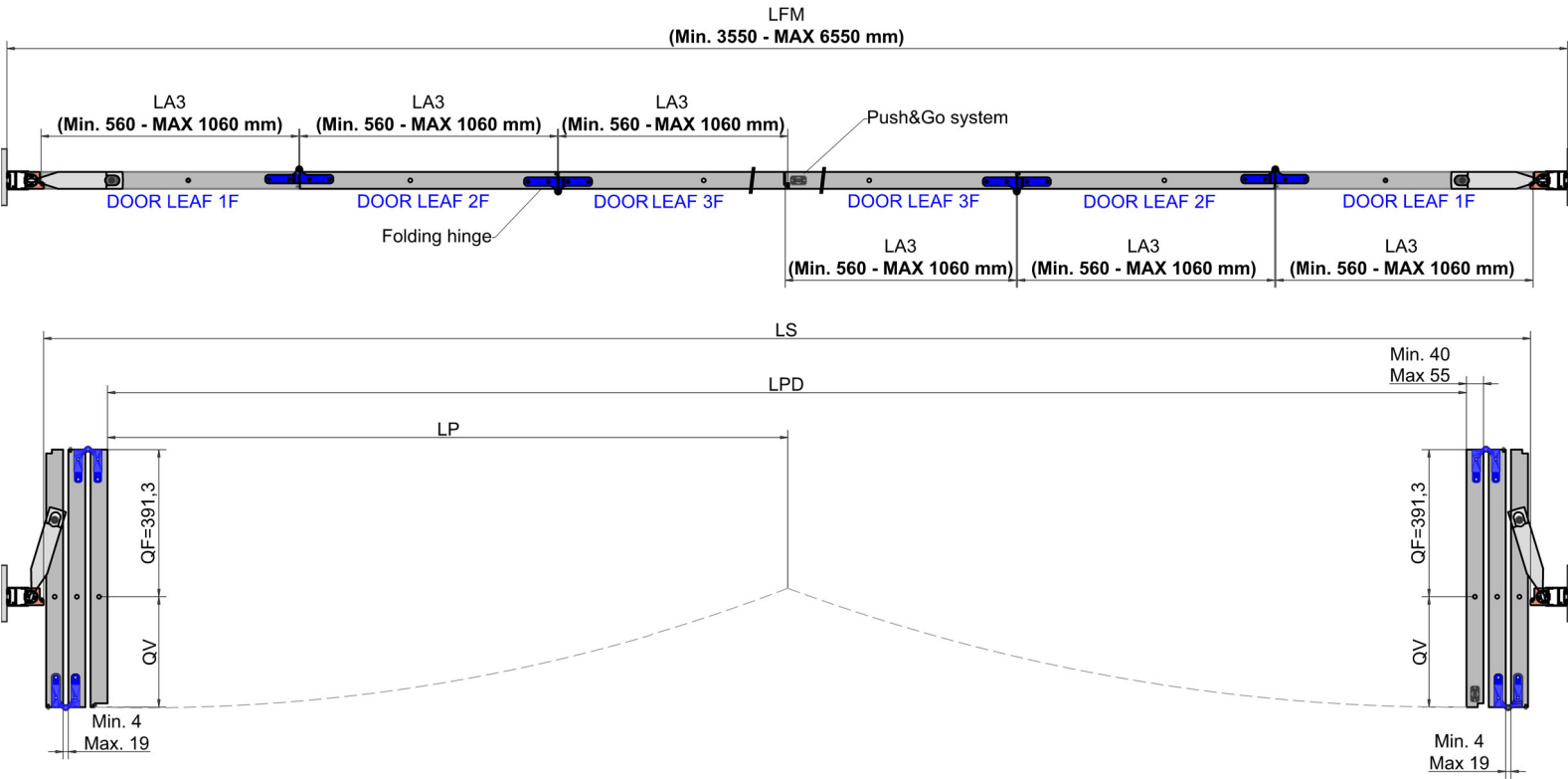

**EQUIPMENT "M"**

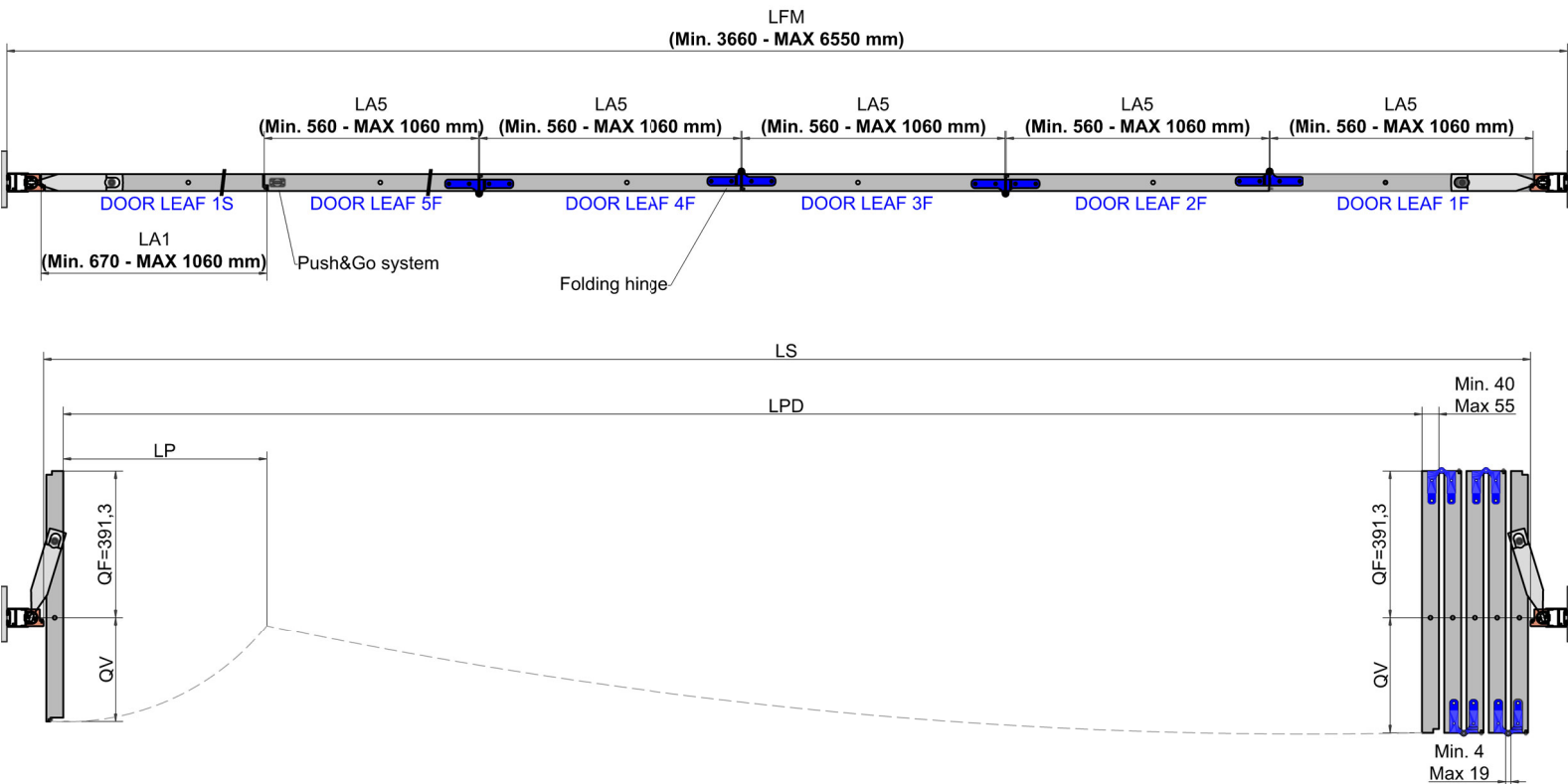

**VERTICAL CEILING SECTIONS**

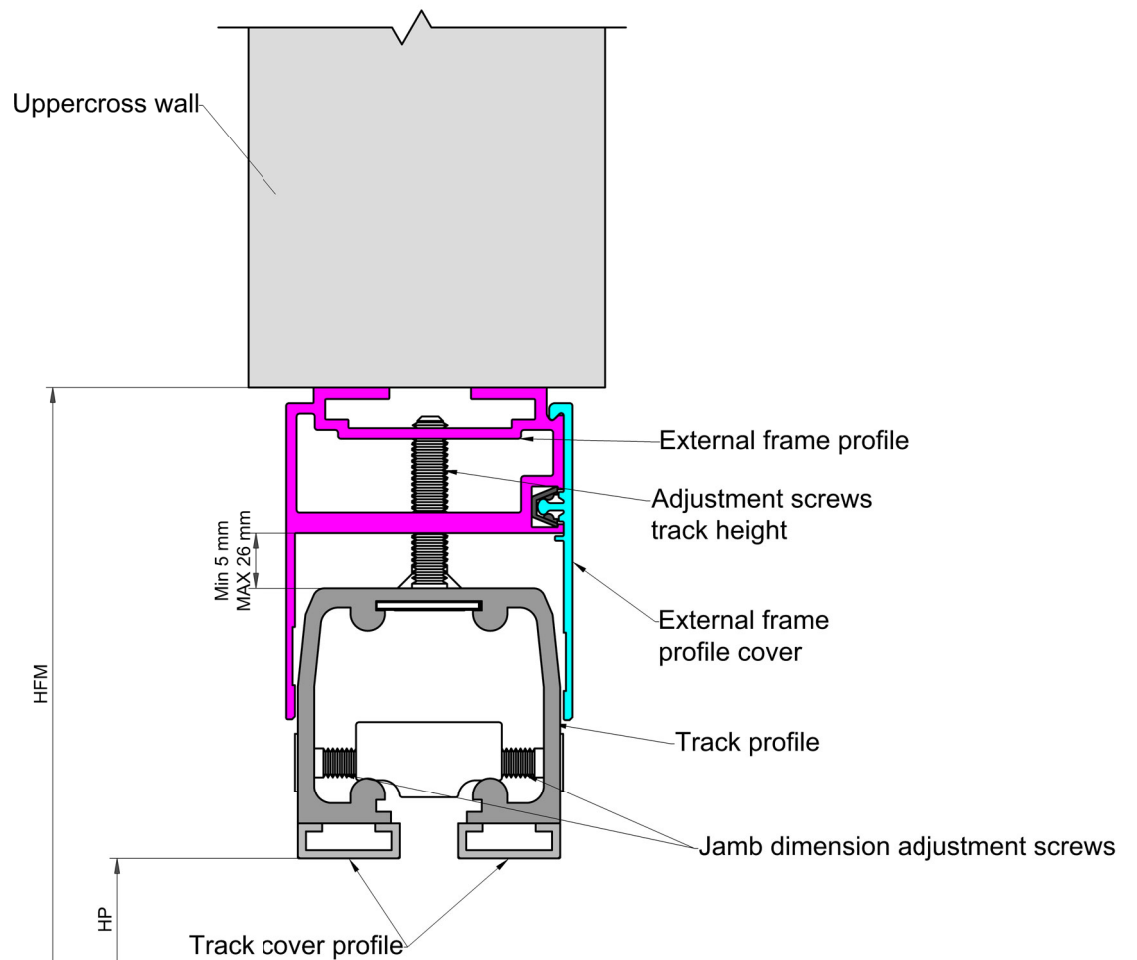
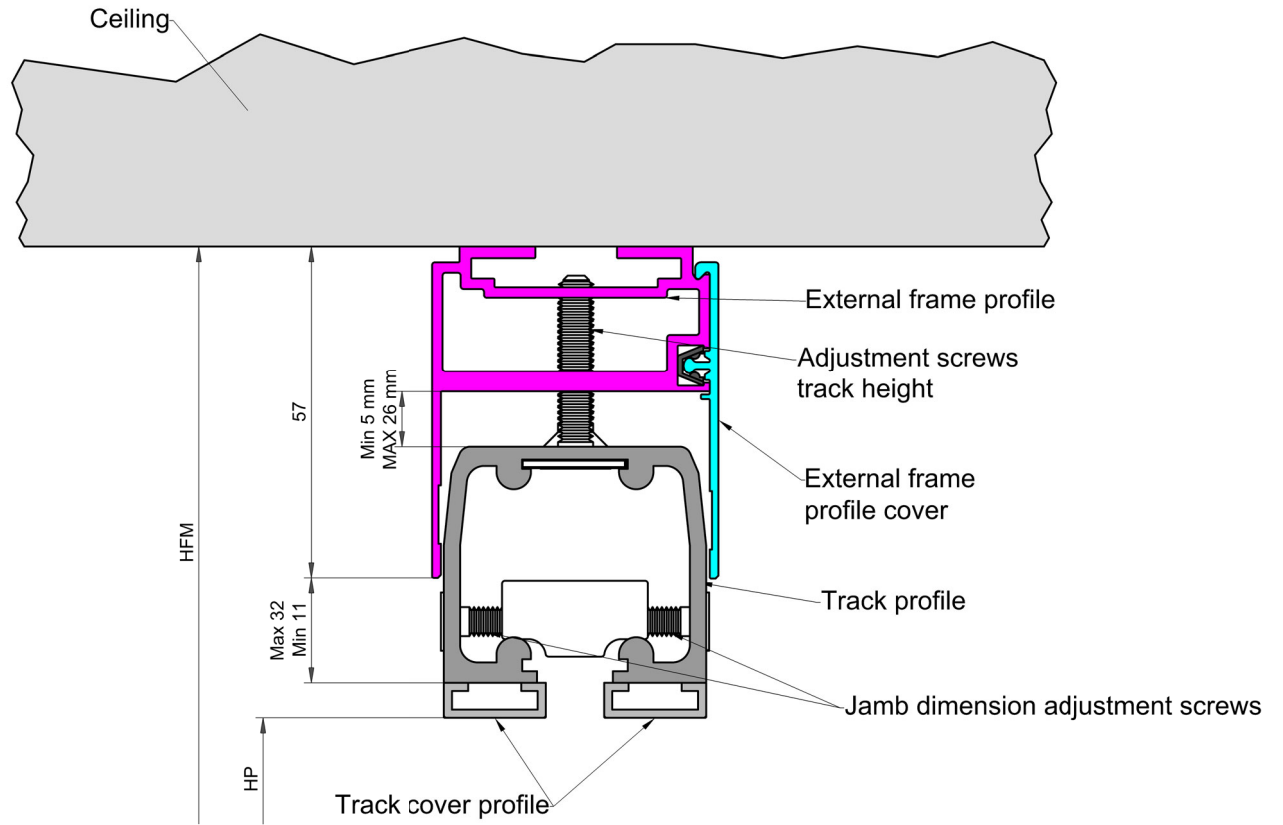



VERTICAL DIMENSIONAL DRAWINGS ON THE CEILING

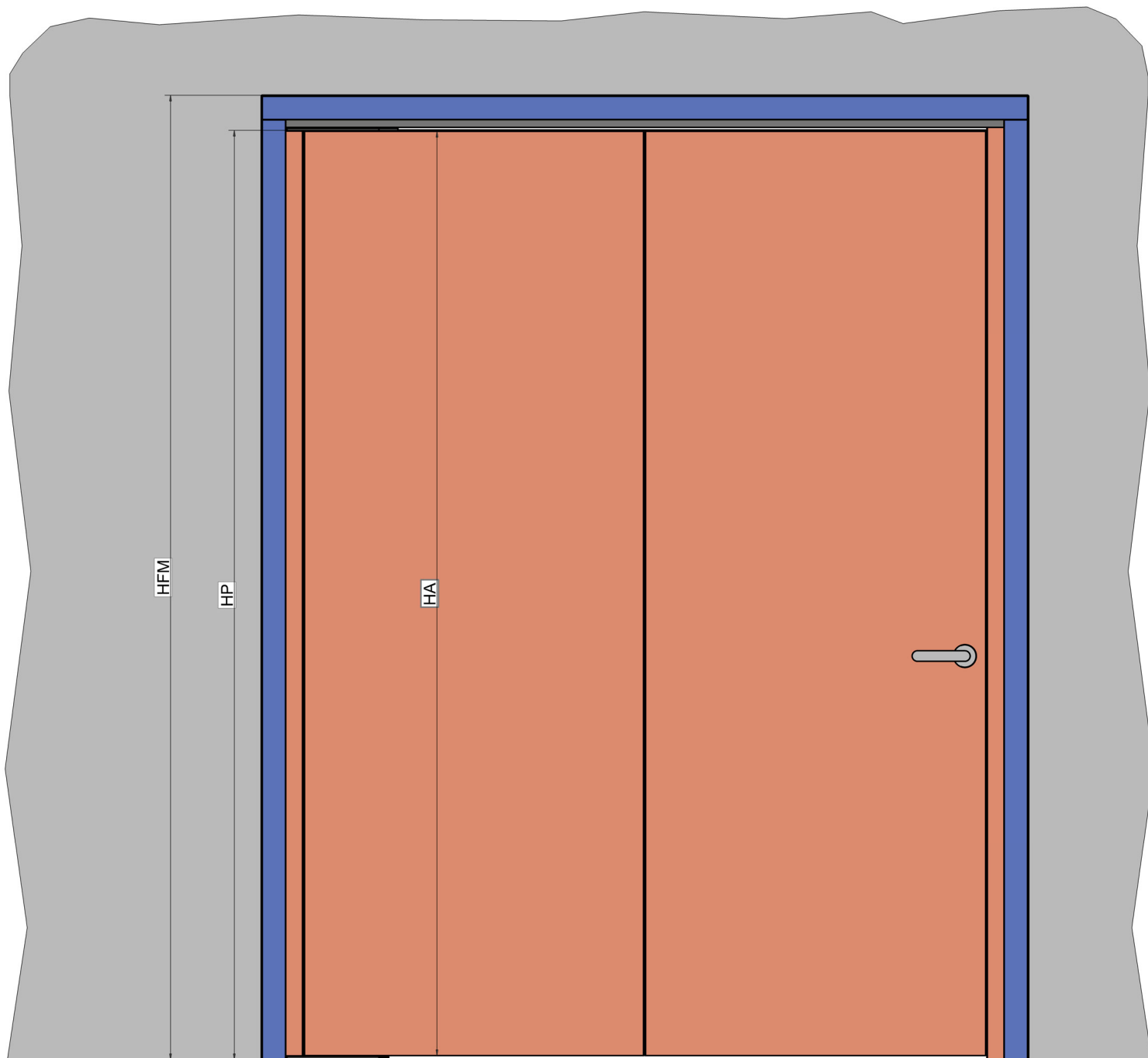

HP = HFM-75

HA = HFM-92

When ordering the rod kit, the wall opening size (HFM) must be provided. According to the communicated dimensions will be supplied a customised rod kit

Max size HFM 3125 mm

Max size HP 3050 mm

For larger sizes, ask Celegon S.r.l. for feasibility.



**VERTICAL SECTION ON FALSE CEILING**

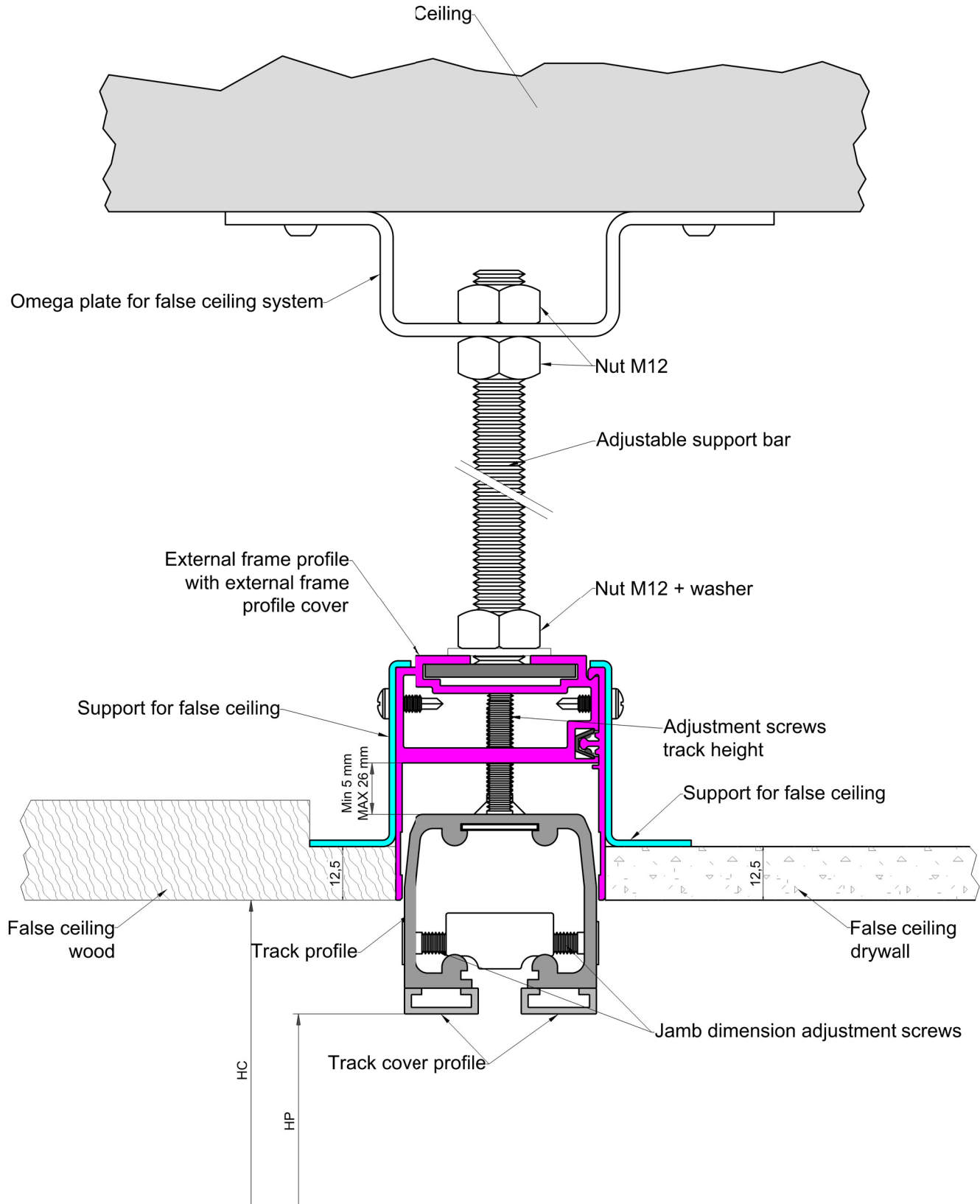

VERTICAL DIMENSIONAL DRAWINGS ON THE FALSE CEILING

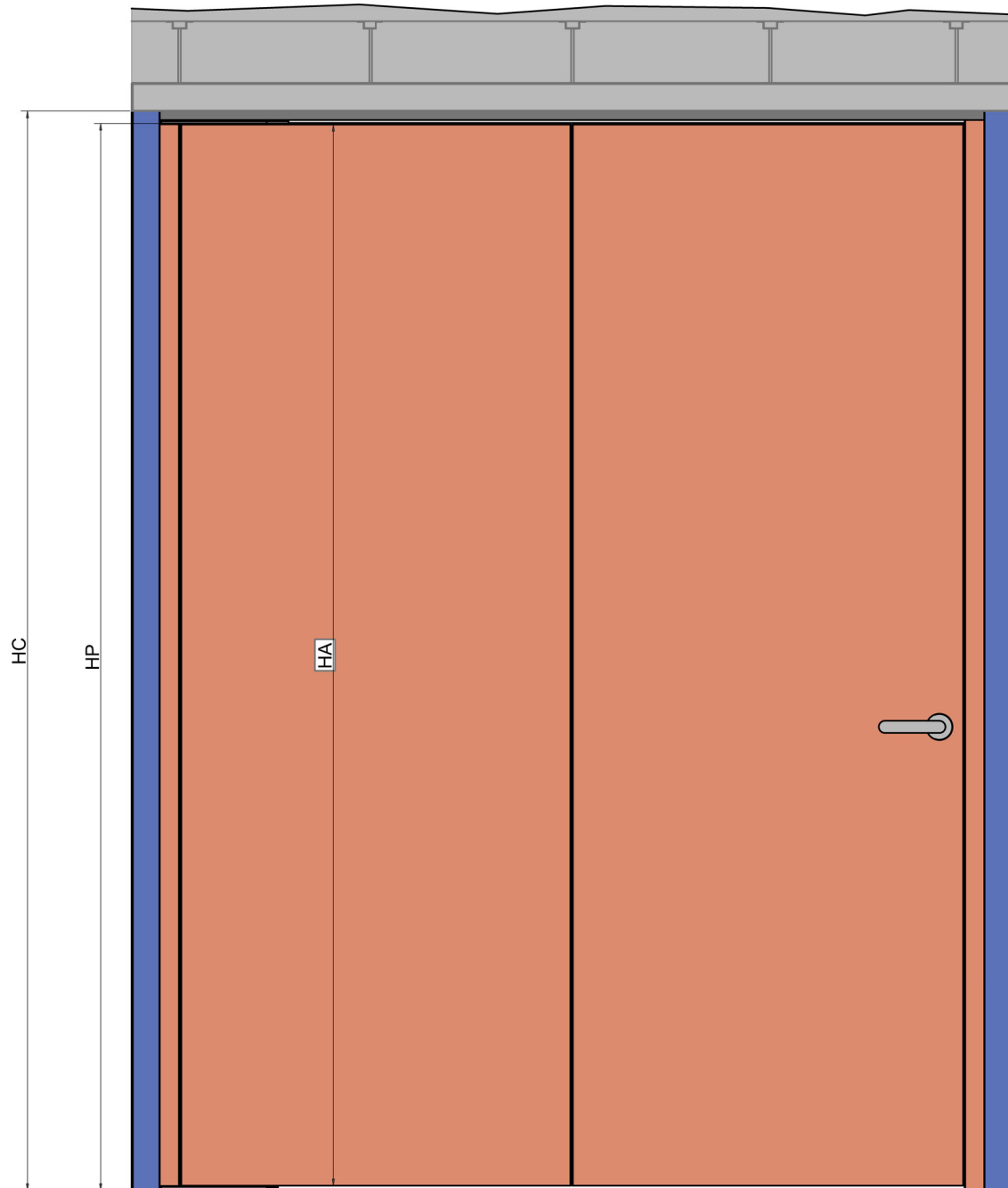

$$HP = HC - 18$$

$$HA = HC - 35$$

When ordering the rod kit, the measurement of the height of the false ceiling (HC) must be provided.

According to the communicated dimensions will be supplied a customised rod kit

Max size HC 3068 mm

Max size HP 3050 mm

For larger sizes, ask Celegon S.r.l. for feasibility.



PROCESSING POSITION ACCORDING TO THE EQUIPMENTS "A; D; H; L"

Single openings: Folding

EQUIPMENT "A" - Folding with 2 door leaves

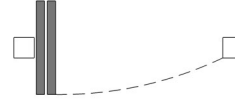
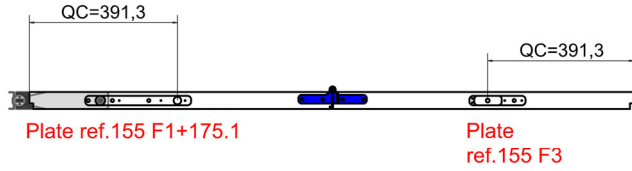

EQUIPMENT "D" - Folding with 3 door leaves

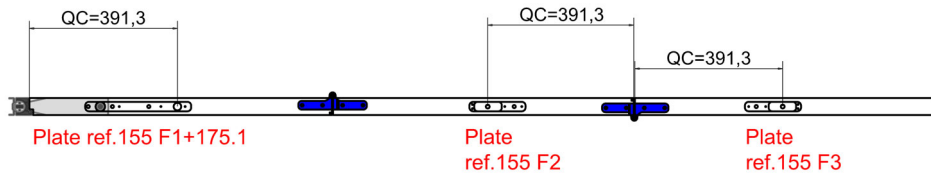

EQUIPMENT "H" - Folding with 4 door leaves

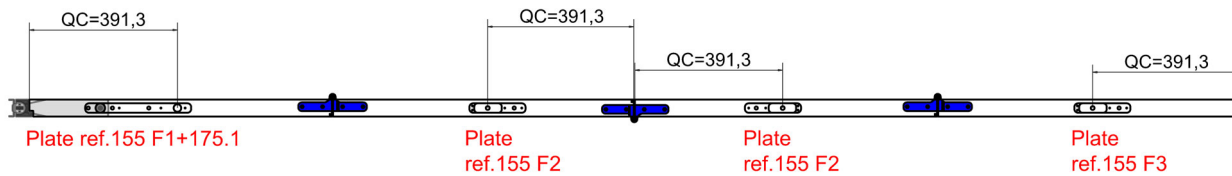

EQUIPMENT "L" - Folding with 5 door leaves

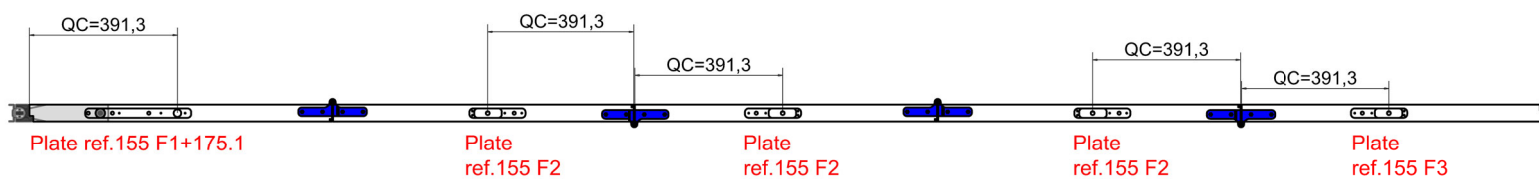

PROCESSING POSITION ACCORDING TO THE EQUIPMENTS "B; E; I; M"

Double openings: Folding + single

EQUIPMENT "B" - Single + folding with 2 door leaves

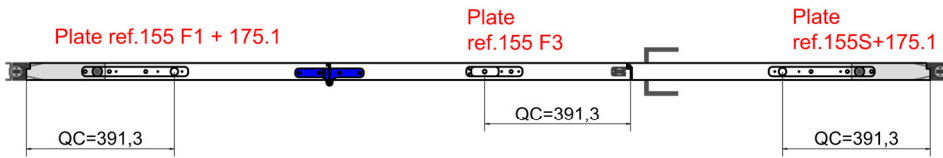

EQUIPMENT "E" - Single + folding with 3 door leaves

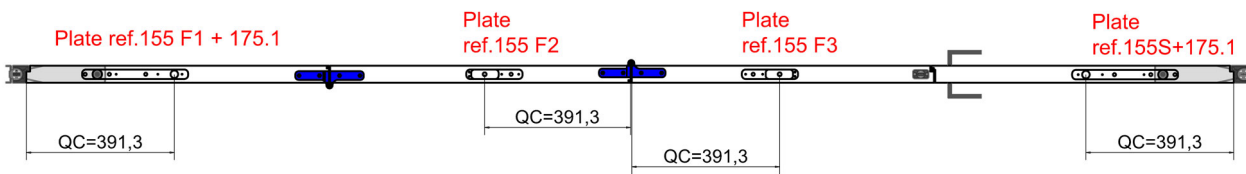

EQUIPMENT "I" - Single + folding with 4 door leaves

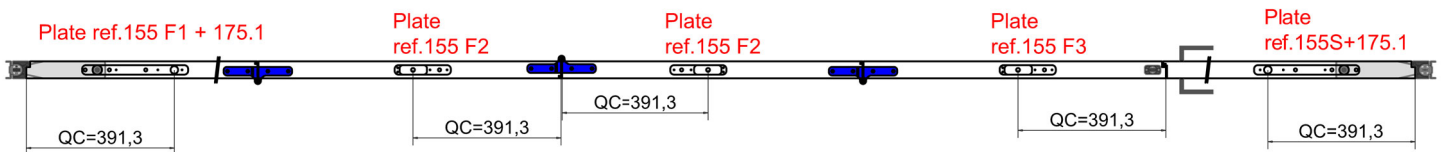

EQUIPMENT "M" - Single + folding with 5 door leaves

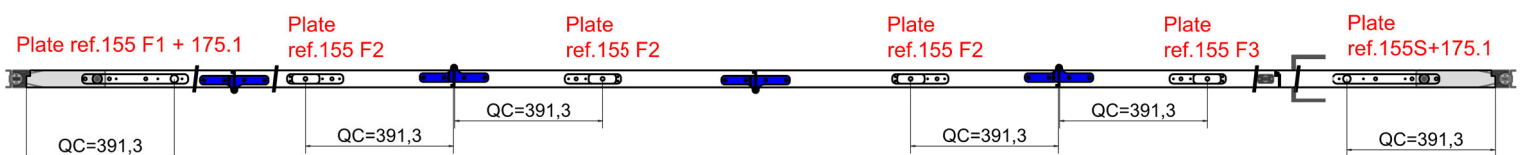

PROCESSING POSITION ACCORDING TO THE EQUIPMENTS "C; F; G"

Double openings: Folding

EQUIPMENT "C" - Folding with 2 door leaves + 2 door leaves

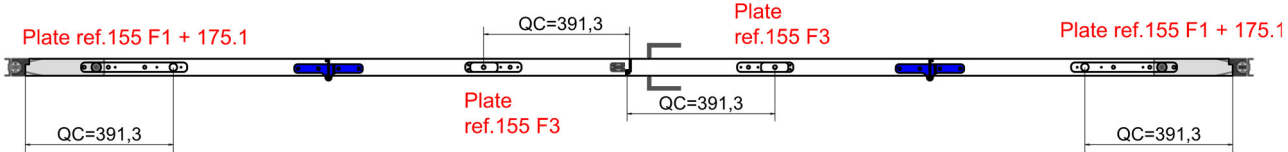
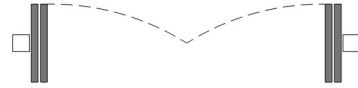

EQUIPMENT "F" - Folding with 3 door leaves + 2 door leaves

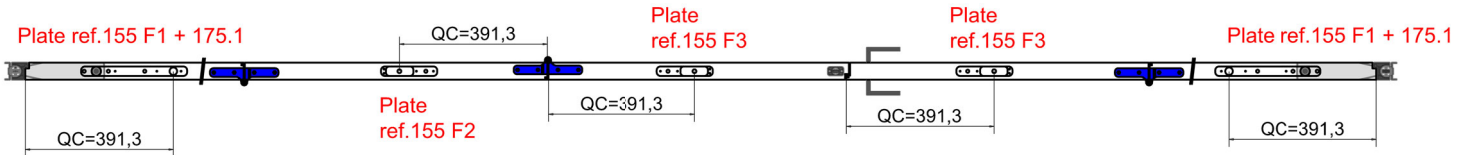

EQUIPMENT "G" - Folding with 3 door leaves + 3 door leaves

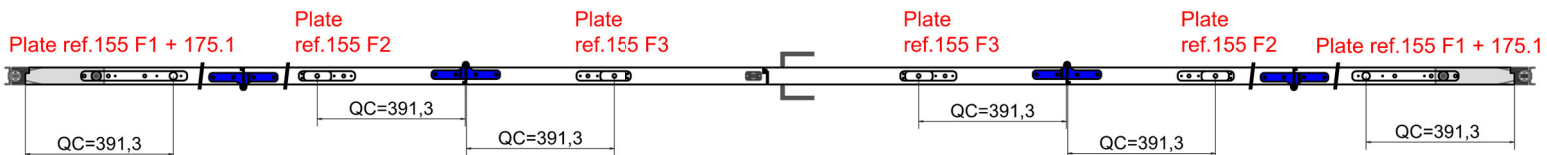
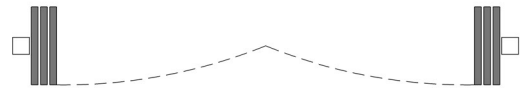

155S and 155F1 PLATE PROCESSING SPECIFICATIONS

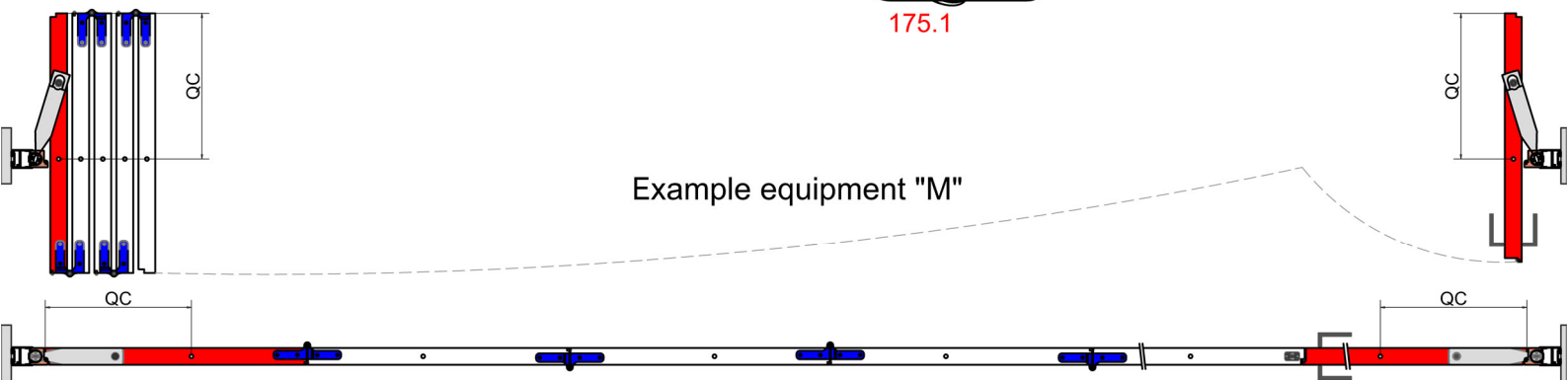
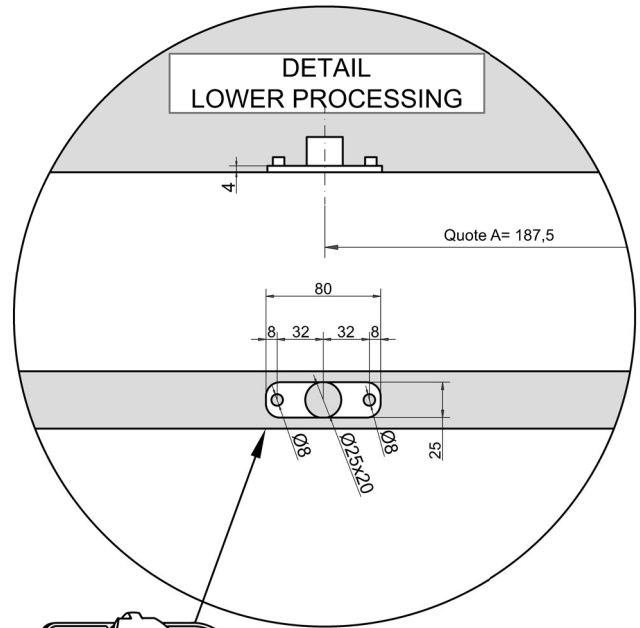
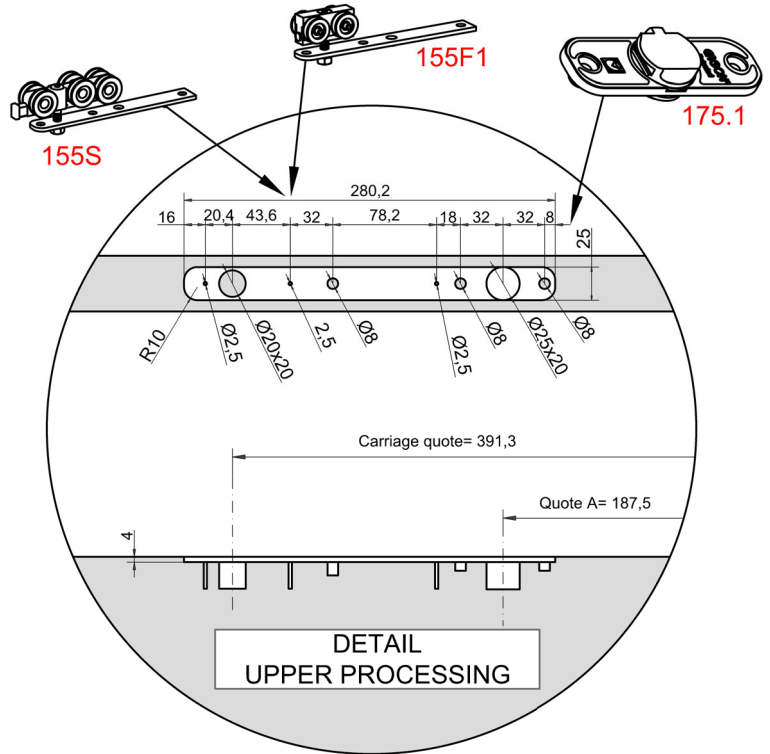
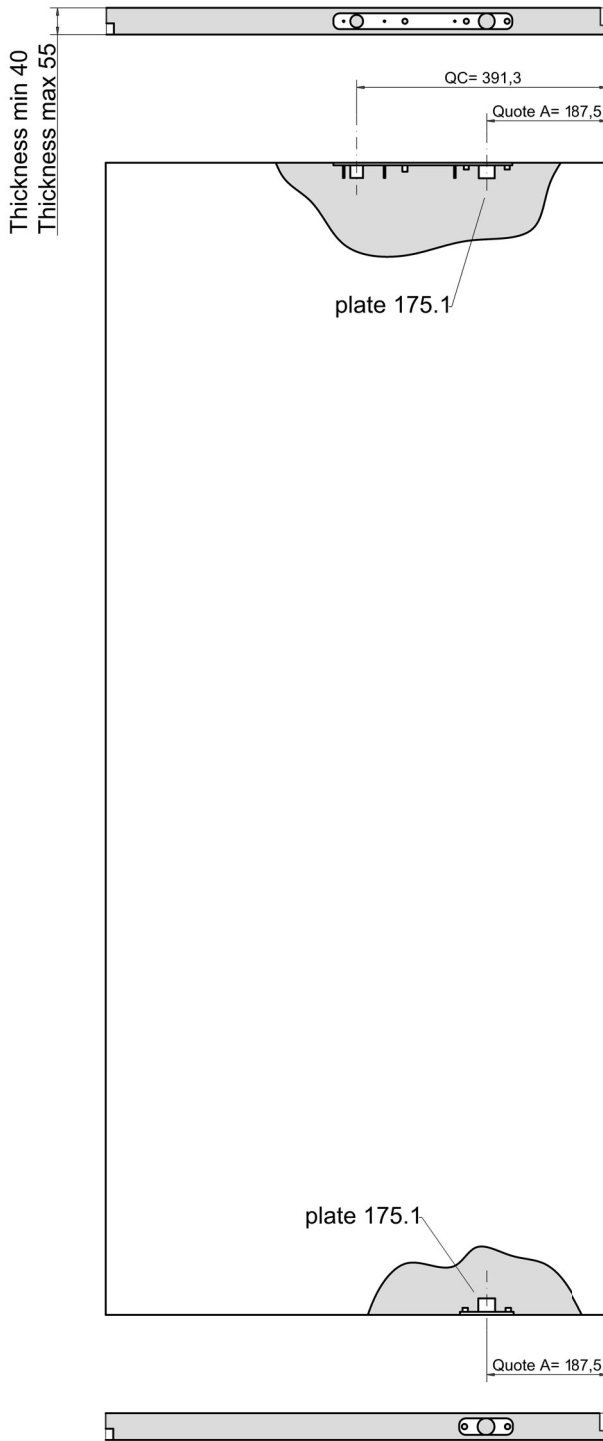

**155F2 and 155F3 PLATE PROCESSING SPECIFICATIONS**

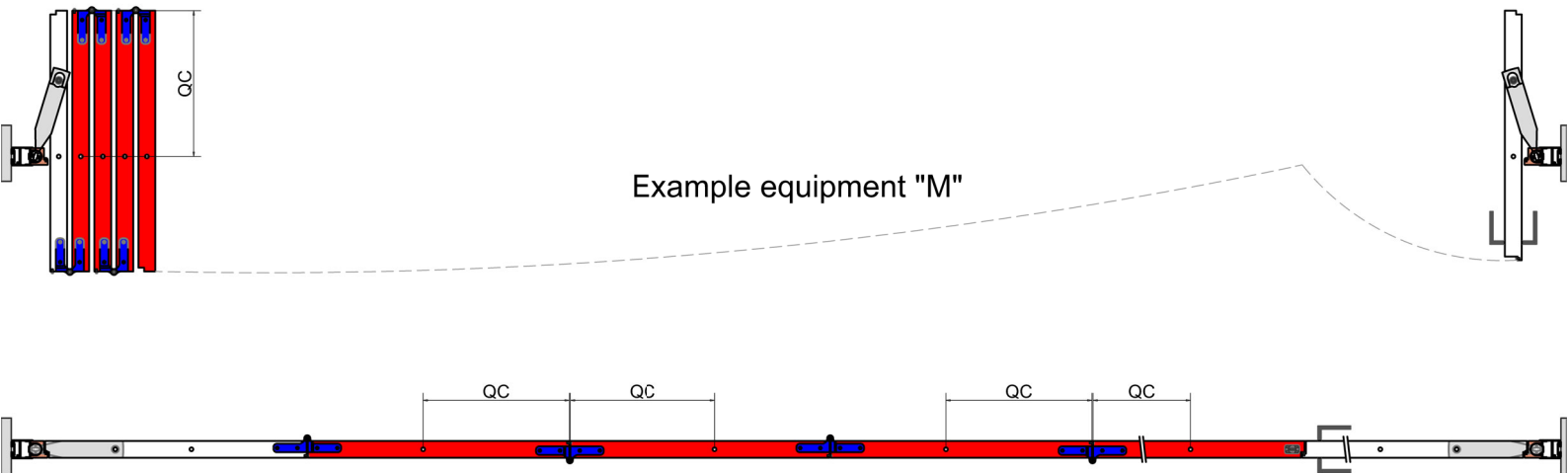
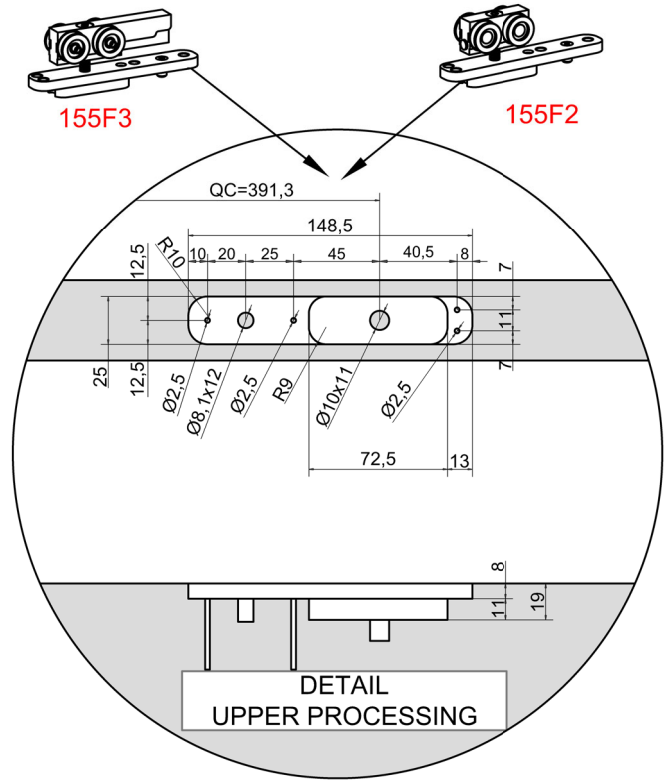
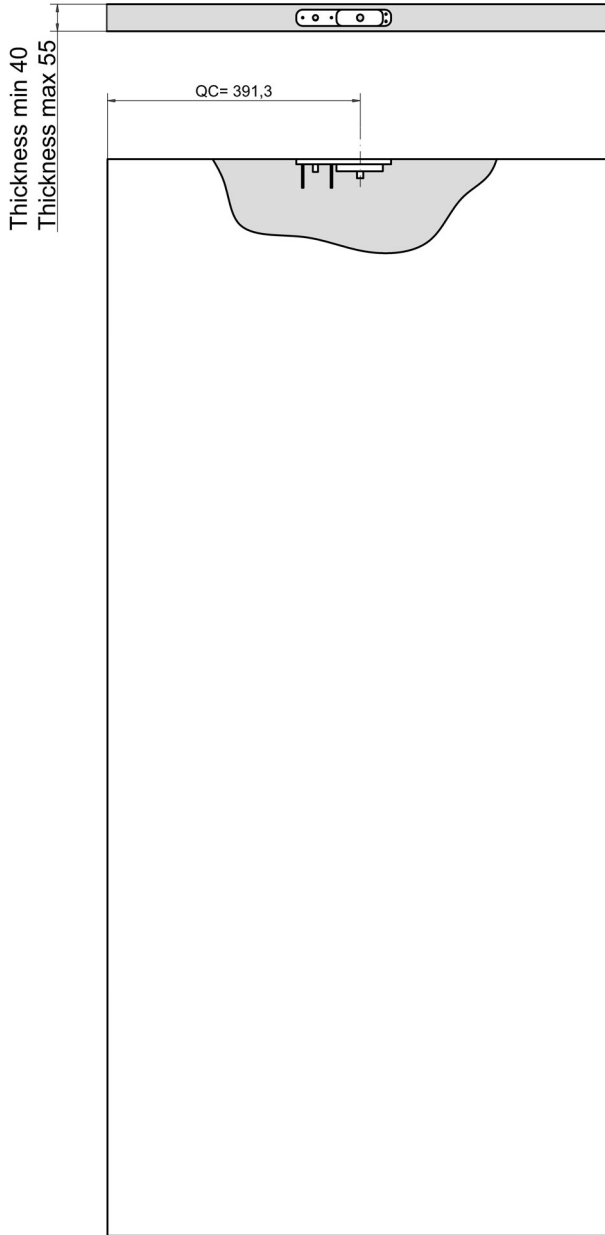

DOOR LEAF PROCESSING SPECIFICATIONS FOR THE GASKET

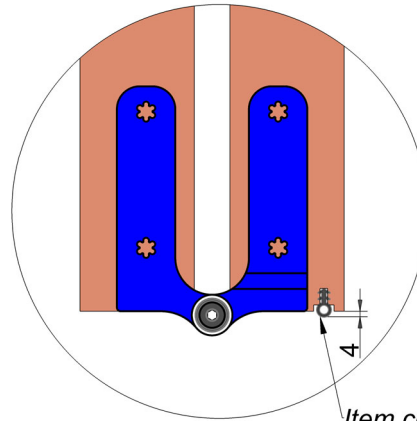
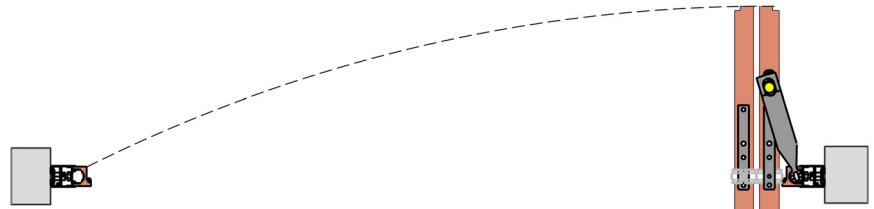

Item code gasket Roverplastik A 109 S 68

Detail on the door leaf processing

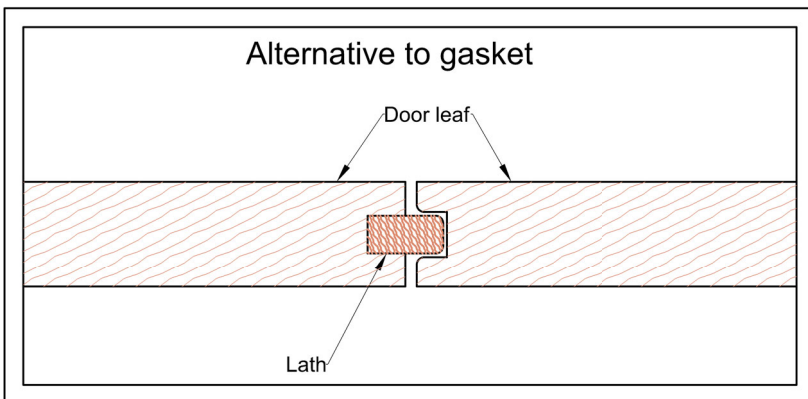
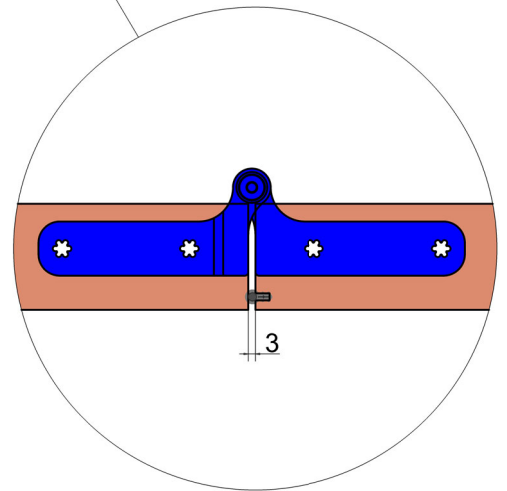
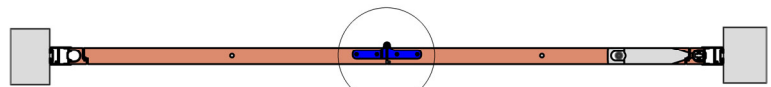
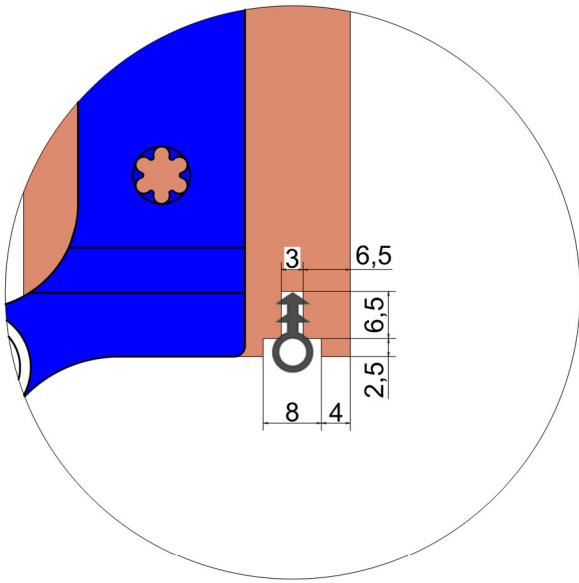

**EXPLODED VIEW OF HINGES KIT**

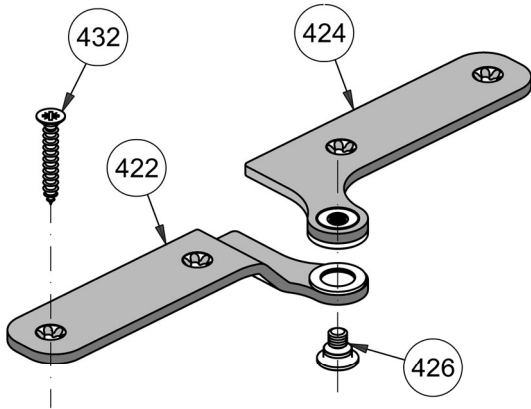

Hinge Right

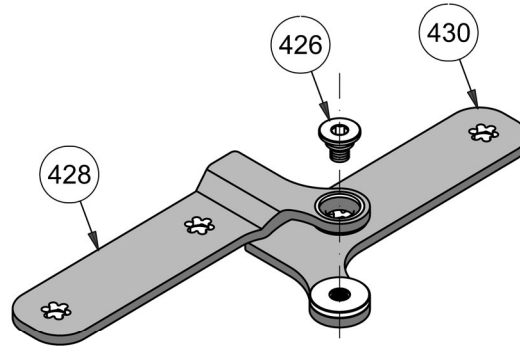

Hinge Left

Parts		
RIF.	Q.ty	Description
422	1	Right hinge curved element
424	1	Right hinge flat element
426	2	Elements union screw M5
428	1	Left hinge curved element
430	1	Left hinge flat element
432	8	Screw for wood TSPtorx Ø4x30

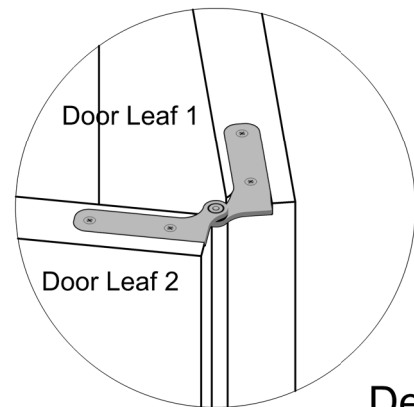
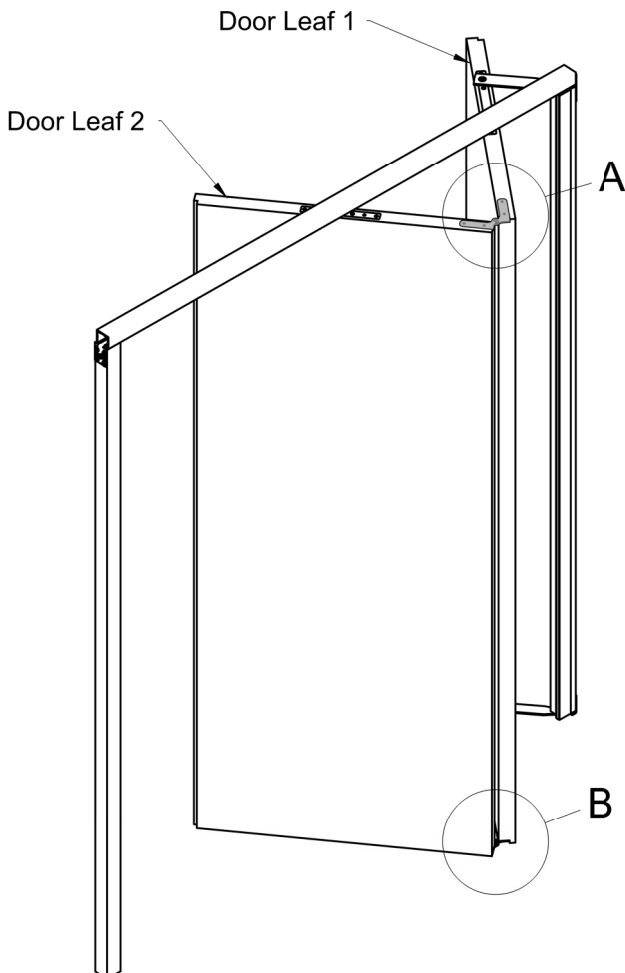

Detail A

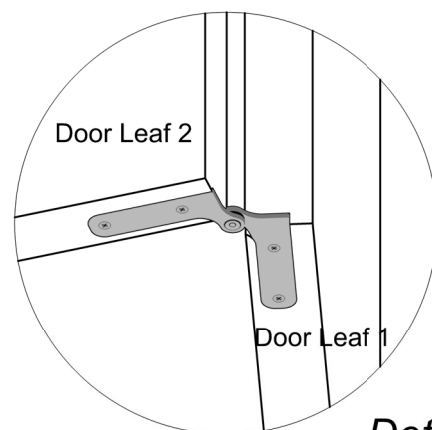

Detail B

## POSITIONING HINGES

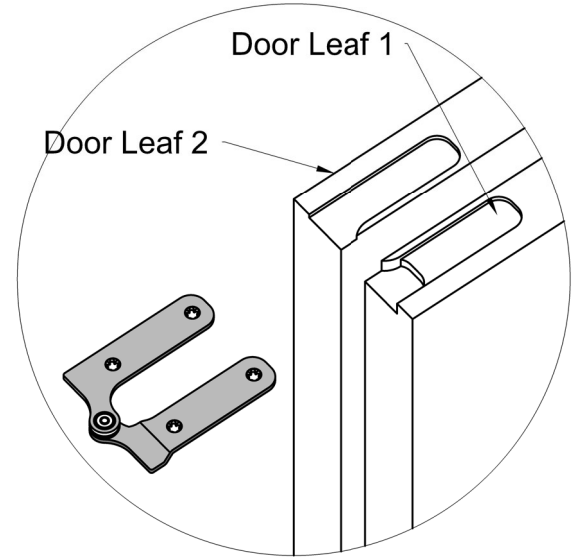
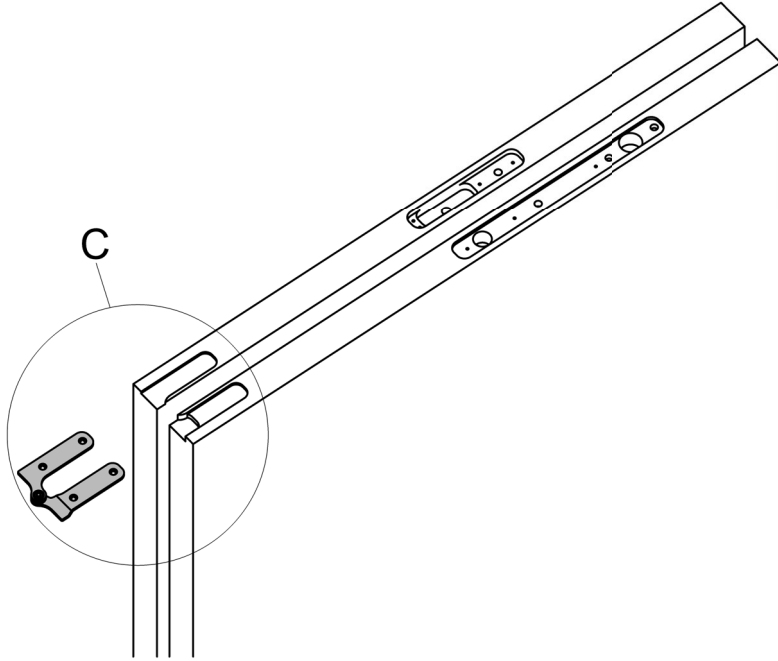

Detail C

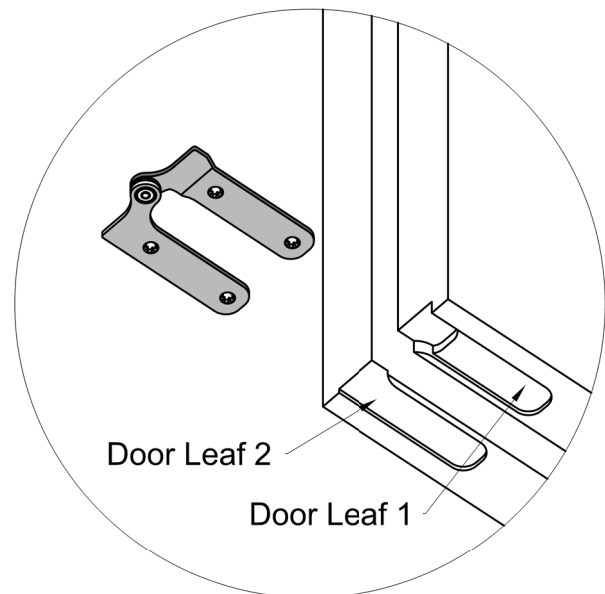
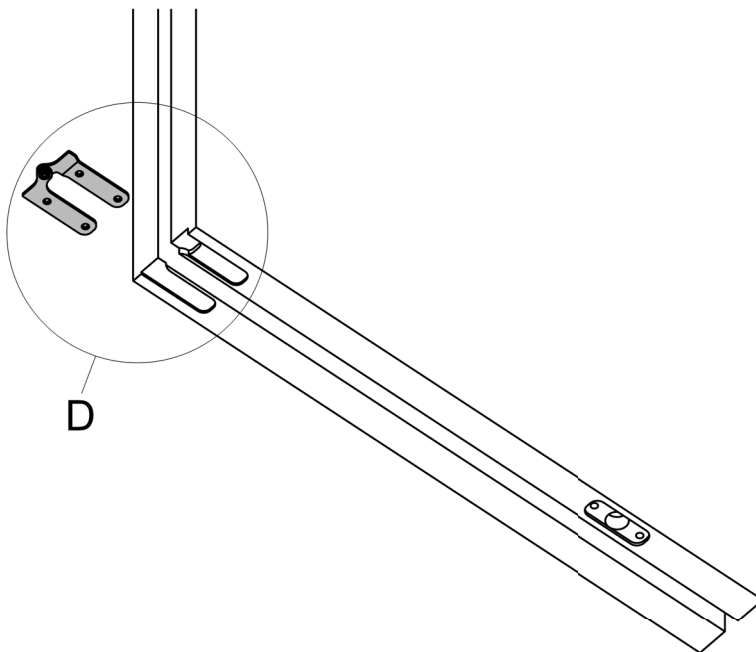

Detail D



## DOOR LEAVES PROCESSING

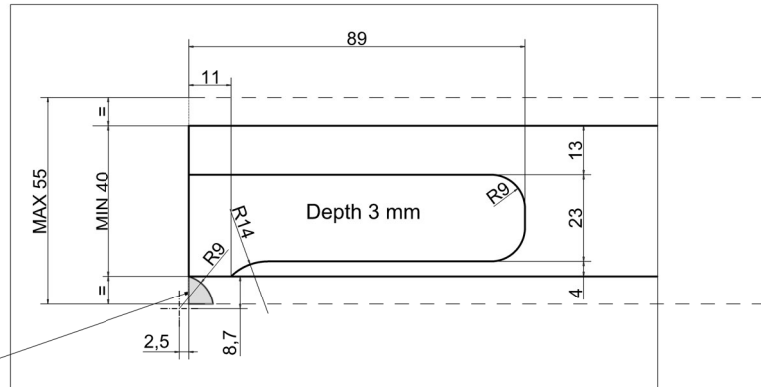

Milling to be done on door thicknesses bigger than 40 mm  
Total depth 9 mm

Detail E

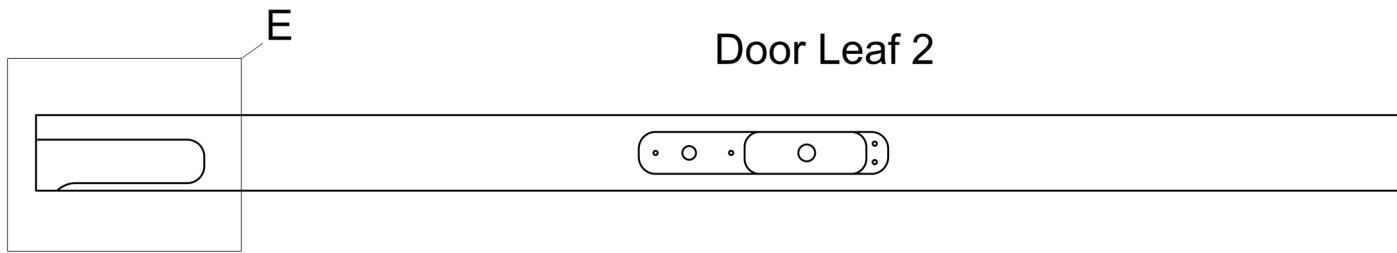

Door Leaf 2

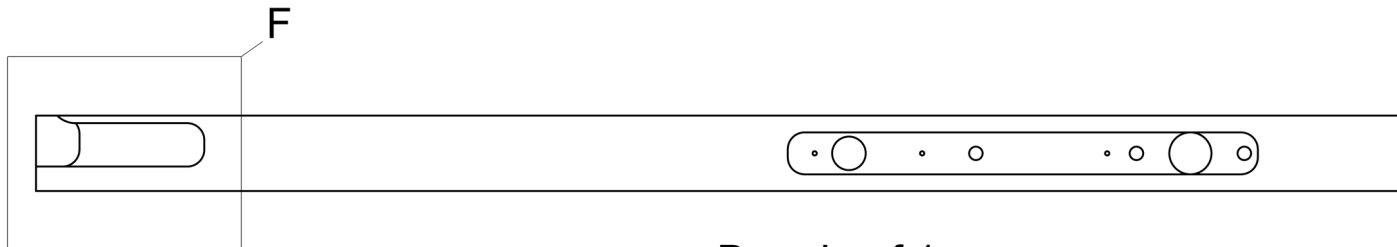

Door Leaf 1

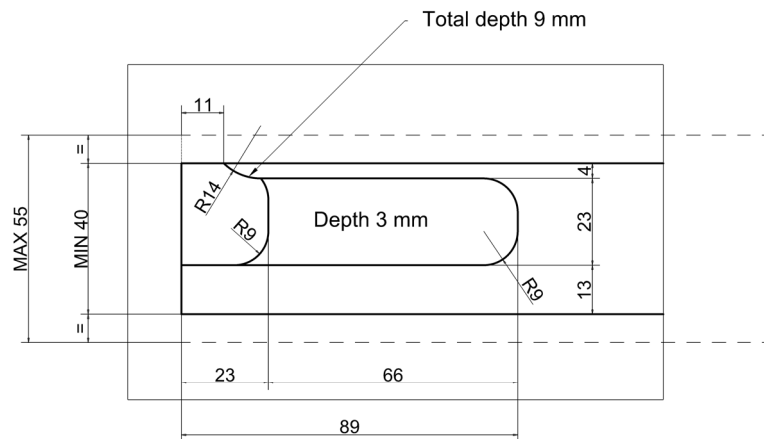

Detail F

## HINGES ASSEMBLY

For door leaves with a thickness bigger than 50 mm, a processing must be carried out as shown in the drawing below, which is useful for inserting the screw (426)

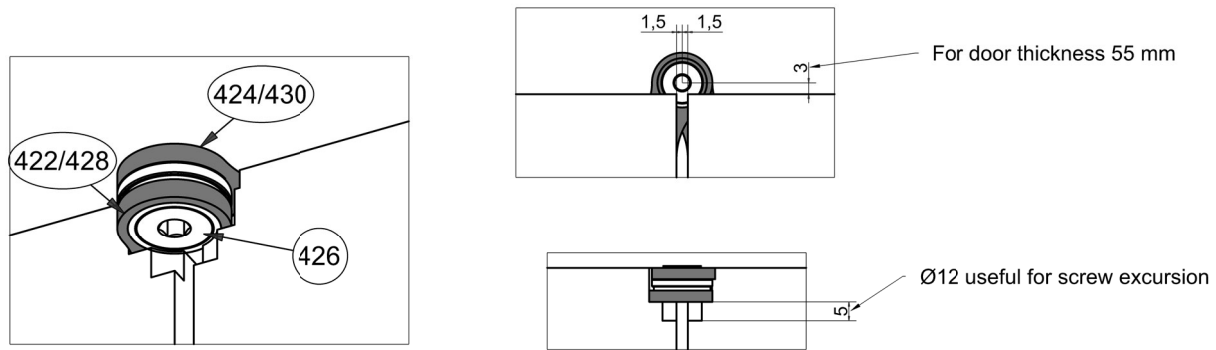

Separate the hinge by completely unscrewing the joining screw (426), fix the single elements on the top and on the bottom of the door leaves

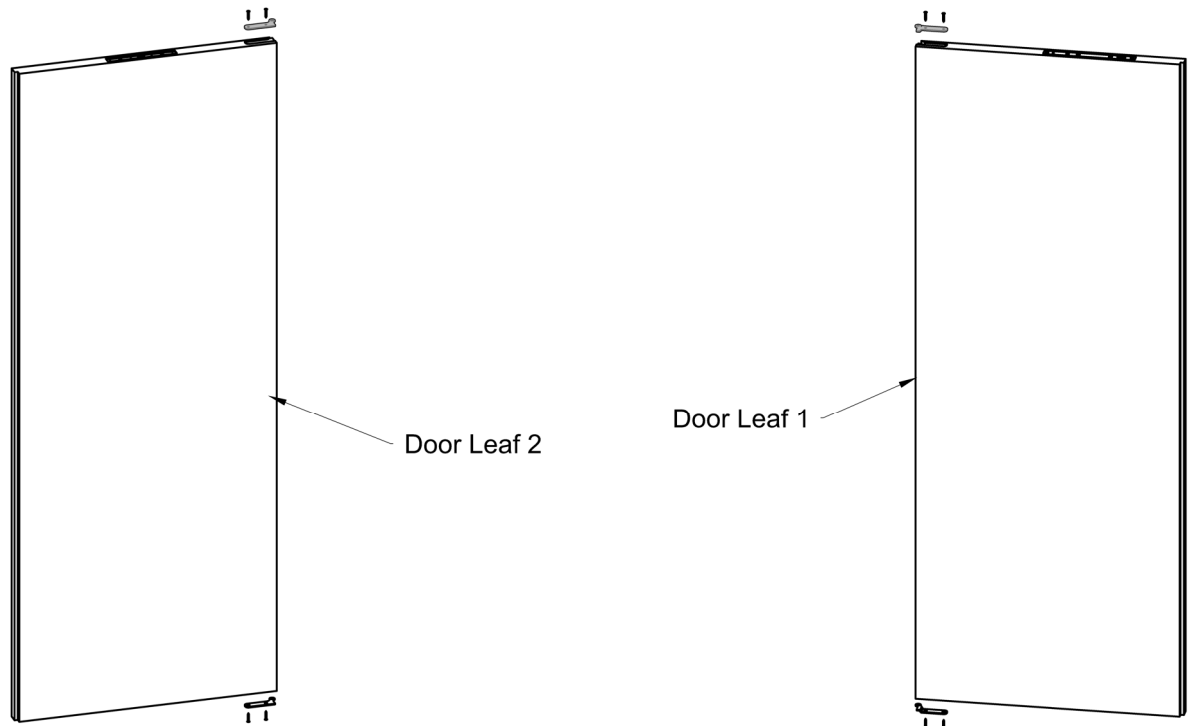

After hanging the doors on the track, put the doors together and join them using the joining screw (426), making sure that the brass bearing and the plastic washer are present

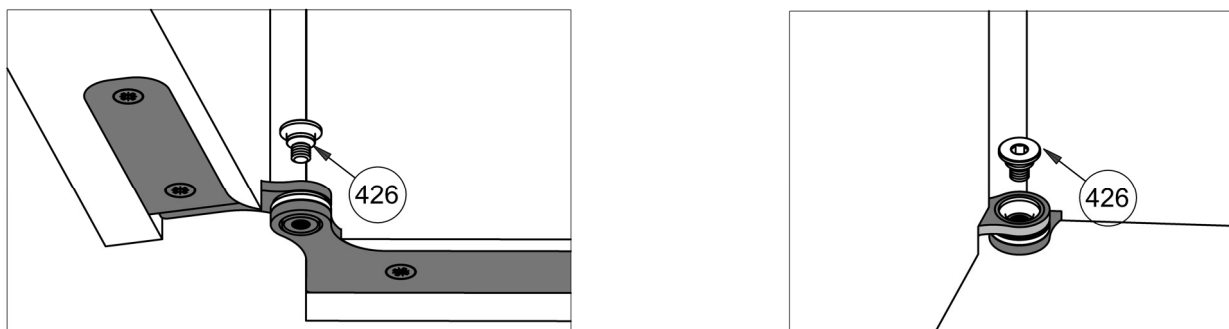

## FOLDING DOOR LEAF LOCKING OPTIONS

### Push&Go EVO (advised)

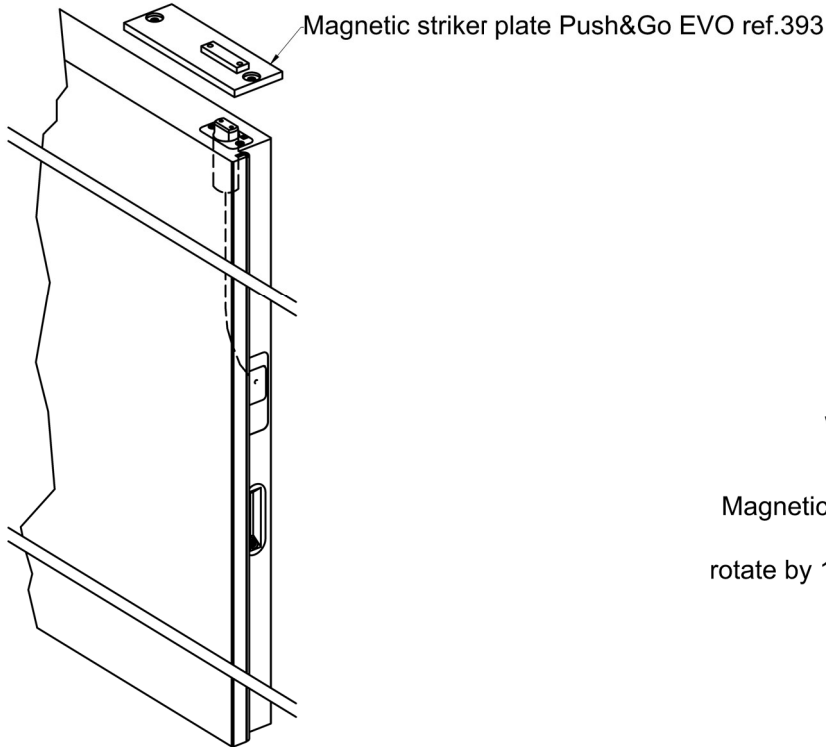

### WITH BOLT

Magnetic striker plate Push&Go EVO ref.393 rotate by 180° and drill a hole for the bolt pin

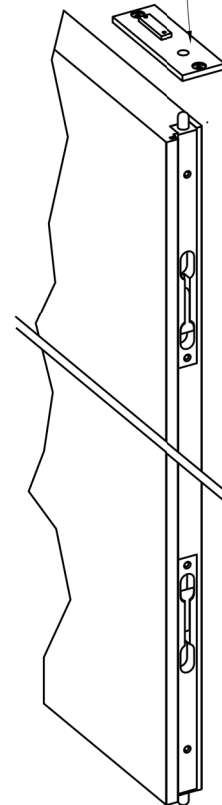

### WITH LOCK FOR FOLDING DOORS

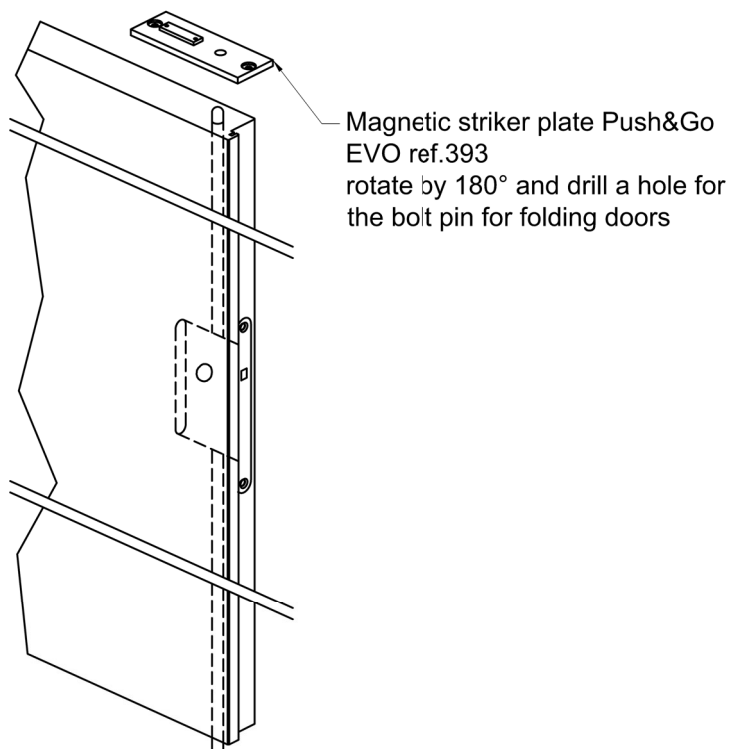

"SOFT OPENING S1" INSTALLATION

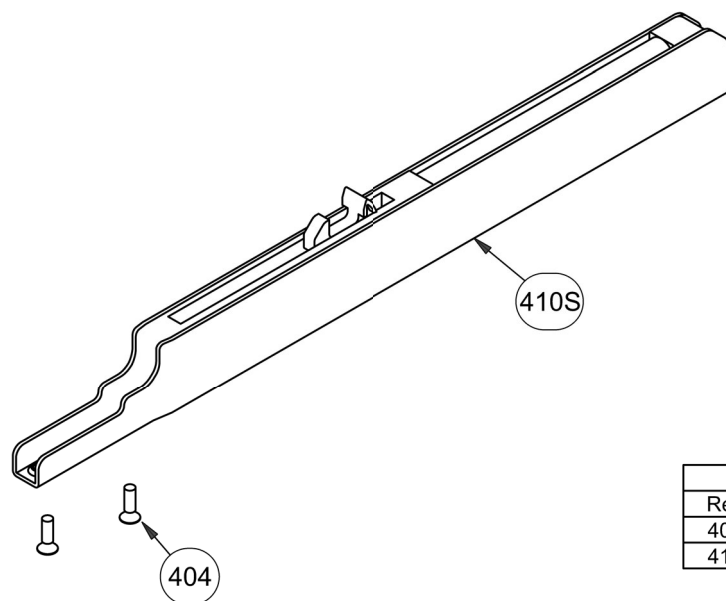

Parts list		
Ref.	Q.ty	Description
404	2	Screw TSP+ M3x8 - ISO 7046
410S	1	Soft Opening S1

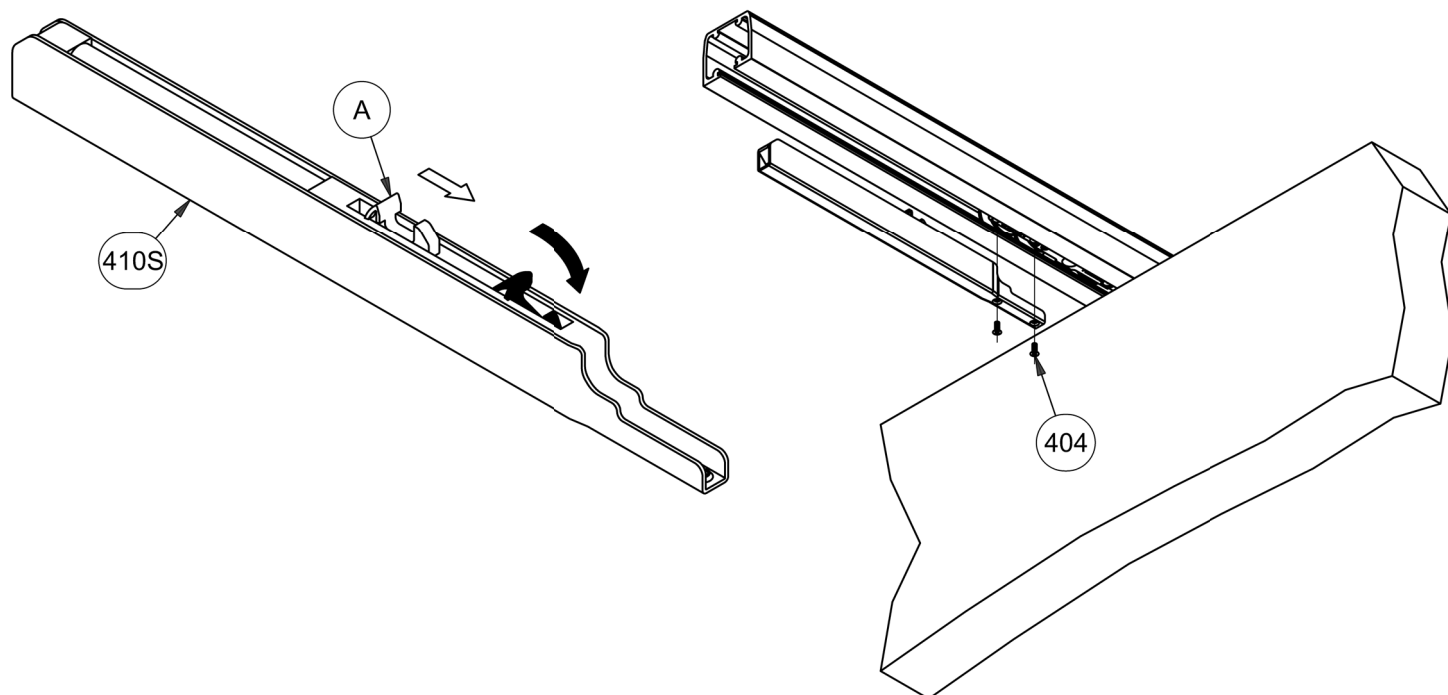

- 1) Push hook (A) to set the Soft Opening (410S).  
Mount Soft Opening unit using the screw provided (404).
- 2) Verify that the Soft Opening system functions properly.  
Finish installing door.

"SOFT OPENING PLUS" INSTALLATION

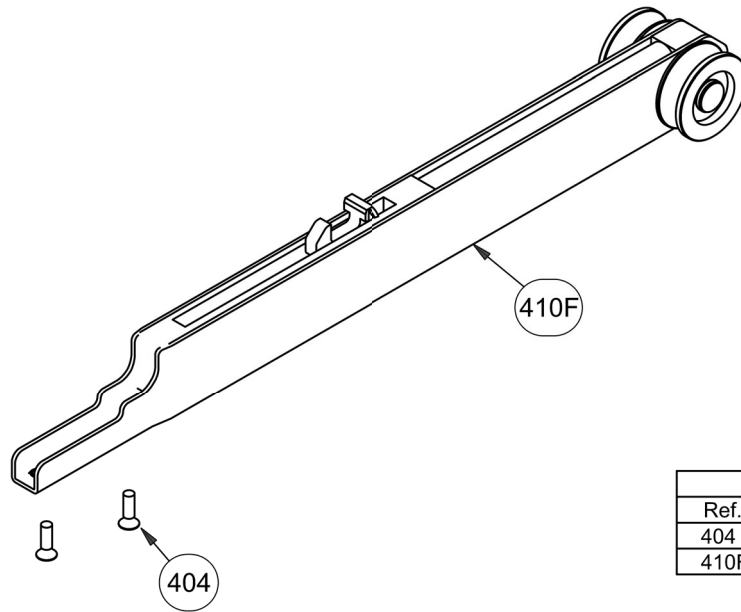

Parts list		
Ref.	Q.ty	Description
404	2	Screw TSP+ M3x8 - ISO 7046
410F	1	Soft Opening Plus

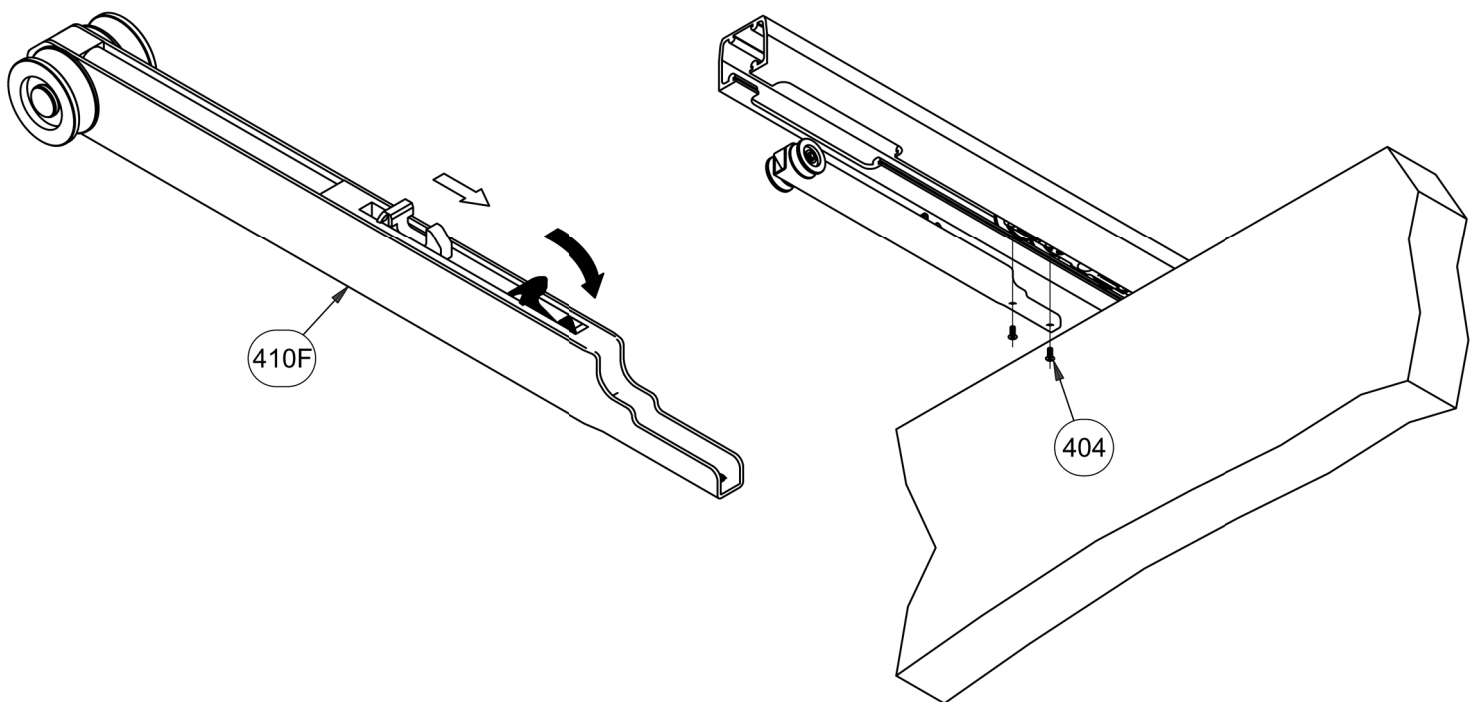

- 1) Push hook (A) to set the Soft Opening (410F).  
Mount Soft Opening unit using the screw provided (404).
- 2) Verify that the Soft Opening system functions properly.  
Finish installing door.





NOTES

---

---

---

---

---

---

---

---

---

---

---

---

---

---

---

---

---

---

---

---

---

---

---

---

-  
-



# MILCASA STORE



2211 2nd Ave North, Suite A105  
Lake Worth, FL 33461  
(888) MILCASA (645-2272)

[milcasastore.com](http://milcasastore.com) | [support@milcasastore.com](mailto:support@milcasastore.com)