

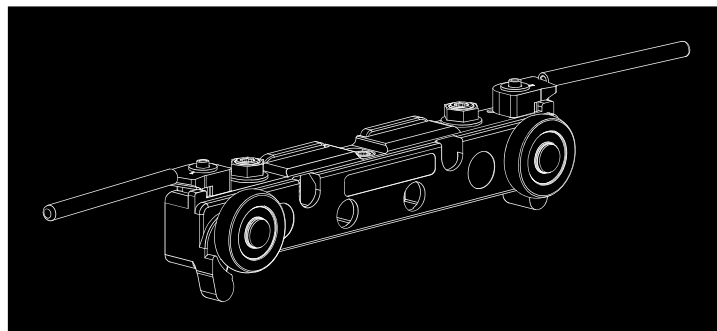





## Magic2 Frame

The perfect meeting point between Magic2 and Universal frame



 26 3/4" ÷ 70 7/8"

 176 lbs

 3/8"

 Dual shock absorbing stop

## Magic2 Frame

Magic2 Frame combines the innovative features of invisible sliding door system Magic2 with the versatility and clean design of our new Universal frame, which allows clean lines, reduced encumbrances and maximal resistance.

Magic2 Frame, designed for glasses in 3/16" and 1/4" thickness, it is therefore the perfect meeting point between functionality and design.

### Minimal and linear design, with the highest resistance

The vertical upright with reduced dimensions will decrease visibility of extruded profiles. The lines will then result linear and clean. The gap, in the upper side of the door as in the bottom's, it is reduced out just like standard swing doors and no additional drilling or milling processing are needed. The sliding track external cover will shape with the door a continuous surface: everything it contributes to confer to new Universal frame a minimal, but pleasant design.

Tubular extruded profiles, metal joints, maximal grip, load-bearing connectors, bi-extruded gaskets: All components contribute to grant the glass weight to be sustained by vertical uprights and horizontal crosstracks, halving the pressure of it.

"The new UNIVERSAL frame is the perfect answer to the demand of an elegant, performant and high resistant product."

### Versatility and resistance

The new Universal frame's extruded profiles are tubular in order to grant maximum resistance and are assembled by metal joint connectors, without any additional drilling processing requirement: This it allows to cut profile's bars to favourite size, with no additional drilling or milling process, but always granting the best grip.

### Essential and modern design

The vertical upright it has been designed with reduced dimensions in order to extremely limitate the visual impact of extruded profiles.

The sliding track's external aluminium cover aligned with the door, it is shaping a continuous and pleasant line.

### Profiles and accessories

are available in different finishings, from lighter to darker colours, as per latest design trends.

### Reduced vertical and horizontal gap

Into the horizontal crosstrack are inserted dustcover brushes, allowing to fill the gap either in the bottom, as in the upper side, towards the external cover. According to that, horizontal or vertical door's gap will result extremely reduced.

### Dedicated to monolithic and laminated glass

Thanks to innovative extruded profiles, Universal frame result to be highly resistant.

Furthermore, it has been realized an innovative bi-extruded gasket which allows an optimal grip of glass. The bi-extruded gasket will allow to use monolithic and laminated glasses from 3/16" up to 1/4" thickness.

