



MILCASA
S T O R E

Magic² Frame

The original invisible sliding doors system
Il sistema invisibile originale per porte scorrevoli



Tracks / Binari

ALUMINUM FINISHES CODES / CODICI FINITURE ALLUMINIO



8 ... 0.0

01 • (Anodized Silver / Argento - A)	13 • (Brushed Anodized Dark Brown / E3 Spazzolato - E3S)	17 • (Brushed Anodized Nickel / Nichel Spazzolato - NKS)
02 • (Brushed Anodized Silver / Argento Spazzolato - AS)	14 • (Anodized Black / Nero - N)	25 • (Brushed Anodized Graphite / Grafite Spazzolato - GRFS)
12 • (Anodized Dark Brown / E3 - E3)	15 • (Brushed Anodized Black / Nero Spazzolato - NS)	26 • (Anodized Graphite / Grafite - GRF)

01 - 02 STANDARD / 12 - 13 - 14 - 15 - 17 - 25 - 26 SPECIAL

Magic2

COMPLETE BOX KIT / KIT COMPLETO IN SCATOLA



K Complete kit / Kit completo

		0031		Magic2 - Wood Magic2 - Legno					
					1		1100 mm		
					2		1800 mm		
								01	Standard Finish / Finitura Standard

Magic2 Frame

COMPLETE BOX KIT / KIT COMPLETO IN SCATOLA



K Complete kit / Kit completo

		0461		1500 mm - 80kg					
		0462		1100 mm - 80kg					
					1		N.2 Soft damper stoppers N.2 Fermi ammortizzati		
					1		2200 mm		
					2		2600 mm		
					3		3000 mm		
								02	Brushed Anodized Silver / Argento Spazzolato
								13	Brushed Anodized Dark Brown / E3 Spazzolato
								15	Brushed Anodized Black / Nero Spazzolato
								17	Brushed Anodized Nickel / Nichel Spazzolato
								25	Brushed Anodized Graphite / Grafite Spazzolato

Magic2 Vetro

COMPLETE BOX KIT / KIT COMPLETO IN SCATOLA



K Complete kit / Kit completo

		0041		1100 mm - 80kg					
		0042		1800 mm - 80kg					
					1		Glass thk. / Vetri sp. 8 mm (5/16")		
					2		Glass thk. / Vetri sp. 10 mm (3/8")		
					3		Glass thk. / Vetri sp. 12 mm (1/2")		
								02	Brushed Anodized Silver / Argento Spazzolato

Magic2 Mix

COMPLETE BOX KIT / KIT COMPLETO IN SCATOLA



K	Complete kit / Kit completo	
	.	
	0441	Magic2 MIX UP
	0442	Magic2 MIX DOWN
	0443	Magic2 MIX UP
	0444	Magic2 MIX DOWN
	.	
	1	1100 mm → 38-40 mm
	2	1800 mm → 38-40 mm
	3	1100 mm → 42-44 mm
	4	1800 mm → 42-44 mm
	.	
		02 Brushed Anodized Silver / Argento Spazzolato
		15 Brushed Anodized Black / Nero Spazzolato

Magic2 Uni

COMPLETE BOX KIT / KIT COMPLETO IN SCATOLA



K	Complete kit / Kit completo	
	.	
	0451	40 mm - 30 kg
	0452	44 mm - 30 kg
	0453	40 mm - 80 kg
	0454	44 mm - 80 kg
	.	
	1	1100 mm
	2	1800 mm
	.	
		02 Brushed Anodized Silver / Argento Spazzolato
		15 Brushed Anodized Black / Nero Spazzolato

EXAMPLE / ESEMPIO

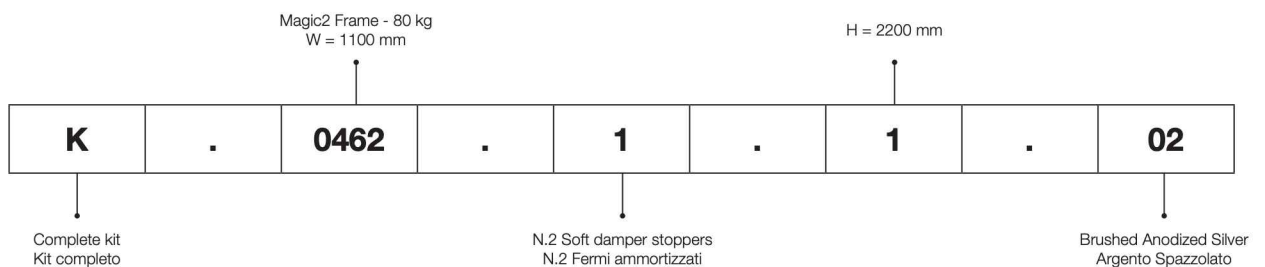

More than 50mm of damping motion

Magic2 system integrates new **PATENTED** dampers with 50 mm of braking motion, 20 mm longer than previous version of **Magic**, while keeping the same door dimensions.

Oltre 50 mm di frenatura

Il sistema **Magic2** integra nuovi fermi ammortizzati **BREVETTATI**, per una frenatura di oltre 50 mm, più di 20 mm rispetto al fermo del modello **Magic**, mantenendo gli stessi ingombri della porta.

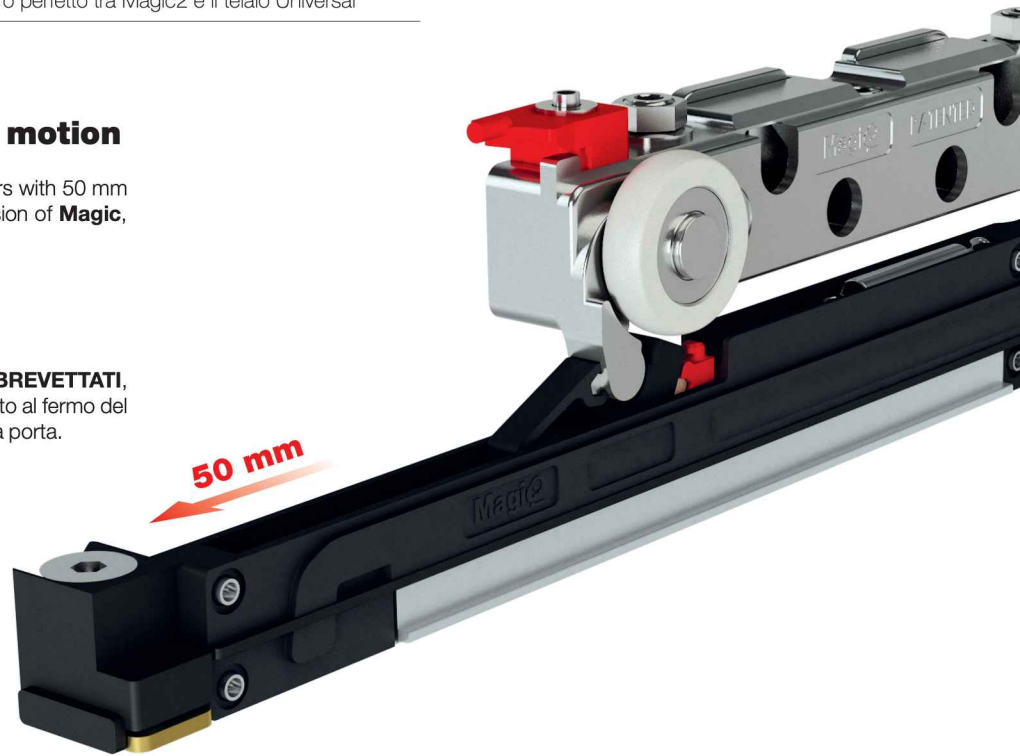

PATENTED

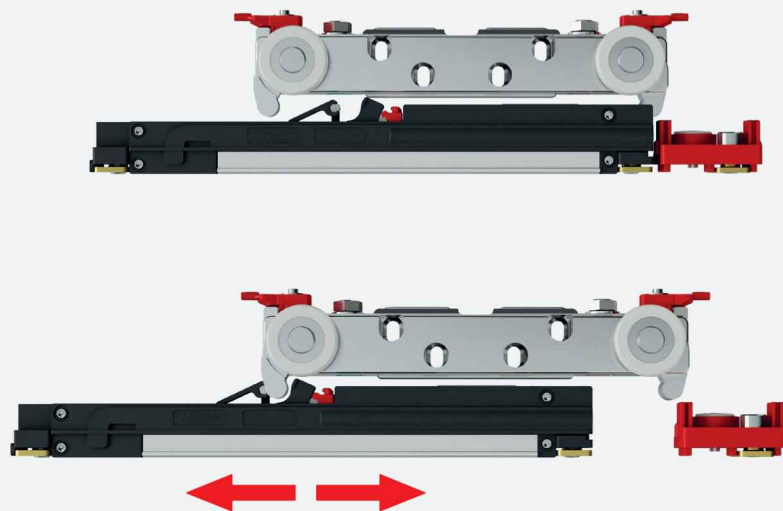

New dampers with adjustable positioning

New **Magic2** adjustable dampers were designed to be independent from wall-spacer wheels. New dampers are suitable to be moved into the track to allow door positioning adjustment.

Nuovi fermi con posizione regolabile

I nuovi fermi del **Magic2** sono stati progettati per essere indipendenti dal distanziale. All'occorrenza si possono spostare per regolare la posizione della porta.

New position of wall-spacer wheels

In **Magic2** system wall-spacer wheels are positioned on the door extremities. The wall-spacer wheels are so positioned in order to protect the door from wall contact, when wall surface are not plane.

Nuova posizione per le ruote distanziali

Nel sistema **Magic2** le ruote distanziali sono posizionate alle estremità della porta. Le ruote distanziali così posizionate proteggono la porta da contatti con la parete, in caso di muri con superfici irregolari.



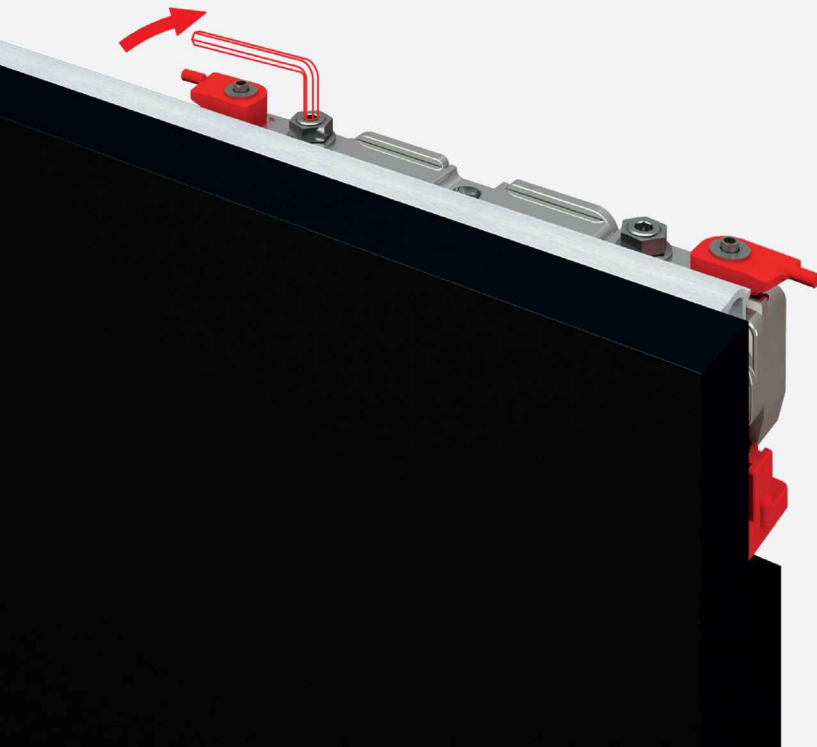

New patented adjustment system

New **Magic² PATENTED** sliding trolley integrates following door adjustments:

- Door height adjustment from floor
- Micrometric adjustment of door from wall
- Micrometric adjustment of door parallelism from wall

Door adjustments of wall distance and parallelism, are meant to compensate possible irregularities of wall. All adjustments are available in the top of sliding trolley, without removing the door.

Nuovo sistema brevettato di regolazione

Il nuovo scorrevole **Magic² BREVETTATO** integra le seguenti regolazioni:

- Regolazione dell'altezza della porta dal pavimento
- Regolazione micrometrica della distanza della porta dalla parete
- Regolazione micrometrica del parallelismo della porta rispetto alla parete

Le regolazioni di distanza e parallelismo della porta, si utilizzano per compensare eventuali irregolarità della parete. Tutte le regolazioni si realizzano dalla parte superiore dello scorrevole, senza sganciare la porta.

Practical anti-jumping system

Magic² sliding trolley includes two new turning anti-jumping activation elements. Turning anti-jumping activation elements are equipped with two safety levers, easy to rotate with no tools required. Safety levers, clearly visible, will have to be removed once anti-jumping system is activated in order to insert end caps.

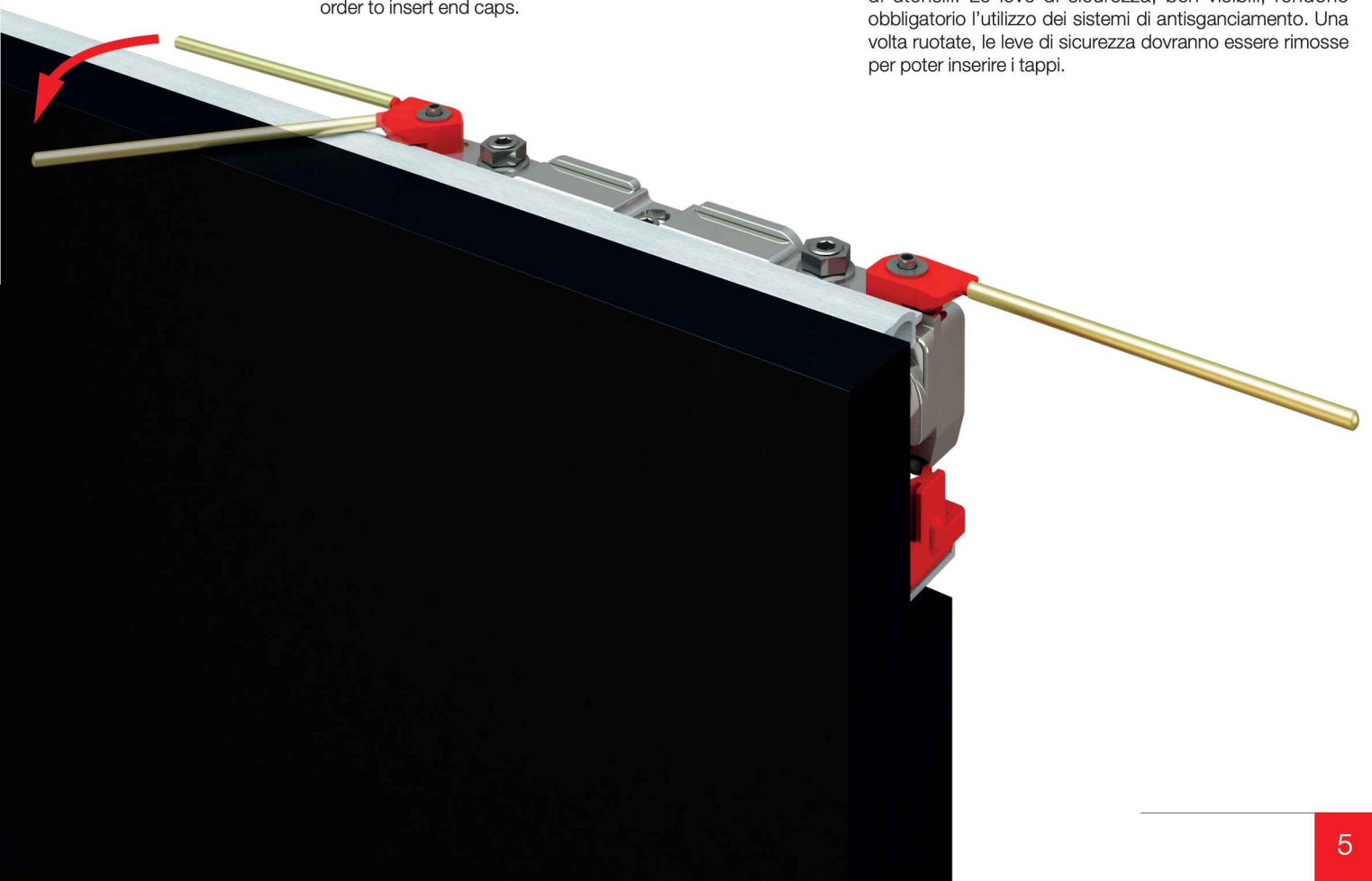

Pratico sistema di antisganciamento

Lo scorrevole **Magic²** comprende due nuovi elementi rotanti di antisganciamento. In questi nuovi elementi sono inserite due leve di sicurezza, per ruotarli senza l'utilizzo di utensili. Le leve di sicurezza, ben visibili, rendono obbligatorio l'utilizzo dei sistemi di antisganciamento. Una volta ruotate, le leve di sicurezza dovranno essere rimosse per poter inserire i tappi.



Silent lower guide

With the purpose of furtherly increase sliding quality, **Magic2** system combines a reinforced lower guide in Zamak (reliable and versatile), which slides in a silent plastic profile.

Guida inferiore silenziosa

Per migliorare ancor di più lo scorrimento, il sistema **Magic2** integra una guida inferiore rinforzata in zama (resistente e versatile), che scorre in un profilo in plastica molto silenzioso.

New patented bottom wheels designed for a better sliding

New **Magic2** bottom wheels are equipped with a **PATENTED** suspension spring system and were designed with a larger diameter, bigger bearing and steel pivots. Rubber surface have been enlarged as well, in order to reinforce wheels and improve sliding quality.

An additional important **PATENTED** innovation in lower sliding system is the introduction of two padded fixed springs which can grant damping function during door motion up to 40kg. Over 40kg of door weight and up to 80kg of maximum load capacity, new bottom wheels will be more flexible than previous version, with their Zamak surface to lean on a rubber internal cylinder, which act as a small shock absorber, granting more stability during sliding motion.

The **Magic2** wheels rubber have high performance:

- it does not leave any trace or sign on sliding surface like floors and walls
- it does not deform over time

Ruote inferiori brevettate per una migliore scorrevolezza

Le nuove ruote inferiori del sistema **Magic2** hanno molleggio **BREVETTATO**, e sono state progettate con diametro, cuscinetti e perni in acciaio maggiorati. Anche il rivestimento in gomma è stato raddoppiato per aumentare la forza e la scorrevolezza delle ruote.

Un'altra importante innovazione **BREVETTATA** nel sistema di scorrimento inferiore è l'inserimento di due molle fisse maggiorate che permettono di ammortizzare il movimento della porta fino ad una portata di 40 kg. Oltre i 40 kg, e fino ad un massimo di 80 kg, queste nuove ruote flettono maggiormente e la superficie realizzata in zama si appoggia su di un cilindro di gomma interno che funge da ammortizzatore supplementare garantendo maggior stabilità.

La gomma delle ruote di **Magic2** è altamente performante:

- non lascia traccia sulle superfici di scorrimento come pavimenti e pareti
- non si deforma nel tempo

KG 0 < KG 40

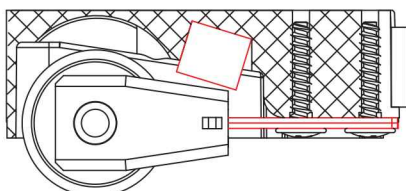

KG 40 < KG 80

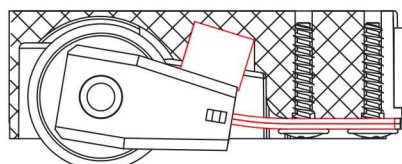

Built-in sliding track with not-through milling

Upper sliding track can be installed "built-in" into a blind milling. Laterally, track's end caps won't be visible, improving even more the aesthetics of door. Door installation and adjustment are not going to be different than usual, because available on the top of the door.

Binario incassato in fresata non passante

Il binario superiore può essere incassato in una fresata cieca. Lateralmente non saranno visibili i tappi del binario, migliorando ulteriormente l'estetica della porta. L'installazione e regolazione della porta non variano perché le regolazioni si effettuano dal lato superiore della porta.

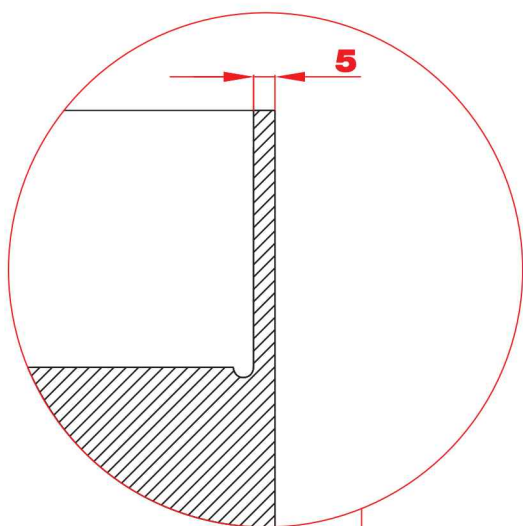

Magic2 Frame

PATENTED

Magic2 Frame combines the innovative features of invisible sliding door system **Magic2** with the versatility and clean design of our new **Universal** frame, which allows clean lines, reduced encumbrances and maximal resistance.

Magic2 Frame, designed for glasses in 5 and 6,5 mm thickness, it is therefore the perfect meeting point between functionality and design.

Magic2 Frame unisce le caratteristiche innovative del sistema invisibile per porte scorrevoli **Magic2** alla versatilità e al design pulito del nostro telaio **Universal**, che offre linee pulite, ingombri ridotti e la massima resistenza.

Magic2 Frame è quindi il perfetto punto d'incontro tra funzionalità e design, ed è progettato per vetri con spessori da 5 a 6,5 mm.





Minimal and linear design, with the highest resistance

The vertical upright with reduced dimensions will decrease visibility of extruded profiles. The lines will then result linear and clean. The gap, in the upper side of the door as in the bottom's, is reduced out just like standard swing doors and no additional drilling or milling processing are needed. The sliding track external cover will shape with the door a continuous surface: everything contributes to confer to new **Universal** frame a minimal, but pleasant design.

Tubular extruded profiles, metal joints, maximal grip, load-bearing connectors, bi-extruded gaskets: All components contribute to grant the glass weight to be sustained by vertical uprights and horizontal crosstracks, halving the pressure of it.

Design pulito e lineare, con la massima resistenza

Il montante verticale con dimensioni ridotte riduce la visibilità degli estrusi. Le linee risultano così lineari e pulite. La luce, sia nella parte alta che nella parte bassa della porta, è ridotta al pari di una porta battente. Non sono necessarie lavorazioni di foratura e fresatura. La copertura in alluminio e la porta formano una superficie continua: tutto concorre a conferire al nuovo telaio **Universal** un design essenziale ma piacevole.

Estrusi tubolari, giunzioni in metallo, aderenza massima, attacchi portanti, guarnizione biestrusa: il peso del vetro è sostenuto dai montanti e dai traversi, e ne viene dimezzata la pressione.

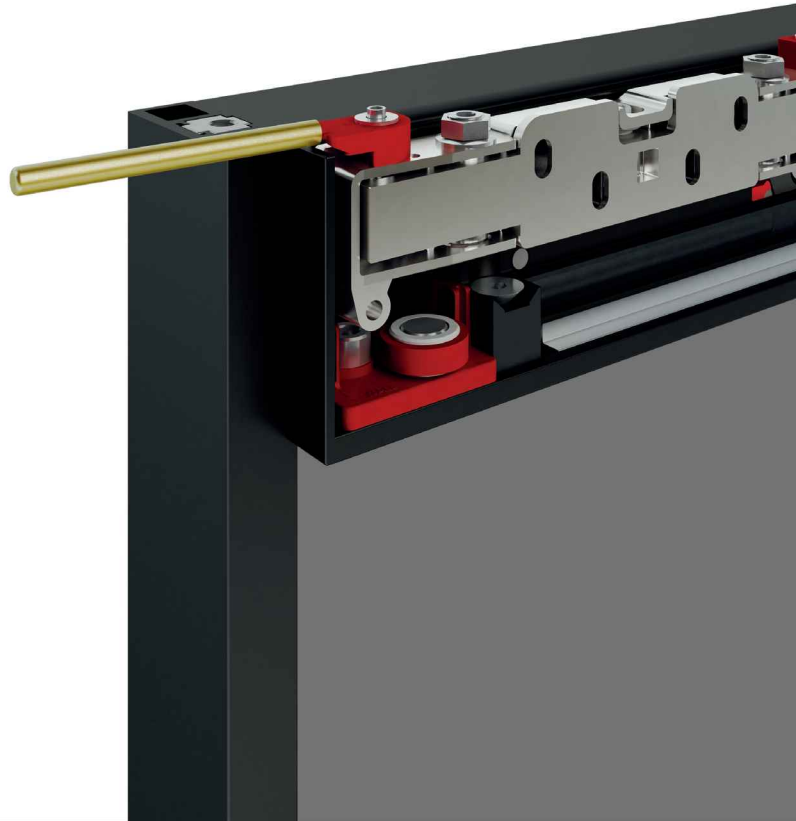

“The new UNIVERSAL frame is the perfect answer to the demand of an elegant, performant and high resistant product”

“Il nuovo telaio UNIVERSAL è la risposta perfetta alle richieste di un prodotto elegante ma funzionale, e resistente”

Versatility and resistance

The new **Universal** frame's extruded profiles are tubular in order to grant maximum resistance and are assembled by metal joint connectors, without any additional drilling precessing requirement: This allows to cut profile's bars to favourite size, with no additional drilling or milling precess, always granting the best grip.



Resistenza e flessibilità

I nuovi estrusi del telaio **Universal** sono tubolari, per ottenere la massima resistenza, e vengono assemblati tramite giunzione in metallo, senza necessità di lavorazioni di foratura: questo permette di tagliare la barra nella misura preferita, senza fori nè fresate, e di ottenere la massima aderenza.

Essential and modern design

The vertical upright has been designed with reduced dimensions in order to extremely limitate the visual impact of extruded profiles. The sliding track's external aluminium cover aligned with the door, it is shaping a continuous and pleasant line. Profiles and accessories are available in different finishings, from lighter to darker colours, as per latest design trends.

Design essenziale e moderno

Il montante verticale ha dimensioni ridotte per limitare estremamente la visibilità degli estrusi. La copertura in alluminio e la porta formano una superficie continua, piacevole alla vista. I profili e gli accessori possono inoltre essere realizzati con diversi tipi di finiture, dai colori più chiari fino a colorazioni più scure, di tendenza.

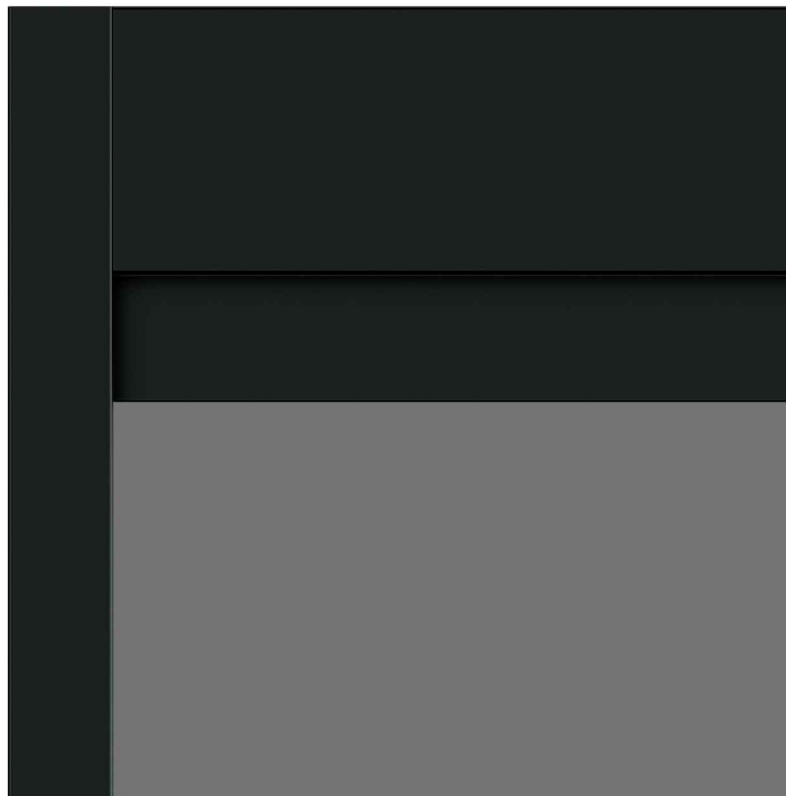

Reduced vertical and horizontal gap

Into the horizontal crosstrack are inserted dustcover brushes, allowing to fill the gap either in the bottom, as in the upper side, towards the external cover. According to that, horizontal or vertical door's gap will result extremely reduced.

Spazio di aria e di luce ridotti

Nel montante orizzontale vengono inseriti gli spazzolini parapolvere, che permettono di chiudere la luce sia nella parte inferiore che nella parte superiore, verso la copertura: lo spazio di aria e di luce risultano così estremamente ridotti.

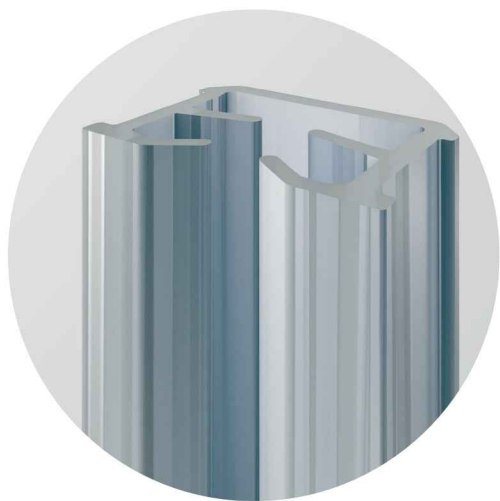

Dedicated to monolithic and laminated glass

Thanks to innovative extruded profiles, **Universal** frame result to be highly resistant. Furthermore, it has been realized an innovative bi-extruded gasket which allows an optimal grip of glass. The bi-extruded gasket will allow to use monolithic and laminated glasses from 5 up to 6,5 mm thickness.

Per vetri monolitici o stratificati

Grazie agli innovativi estrusi, il telaio **Universal** risulta molto resistente. È stata realizzata, inoltre, un'innovativa guarnizione biestrusa che permette un'ottimale tenuta del vetro. Con questa guarnizione, è possibile montare vetri monolitici o laminati con spessori da 5 a 6,5 mm.

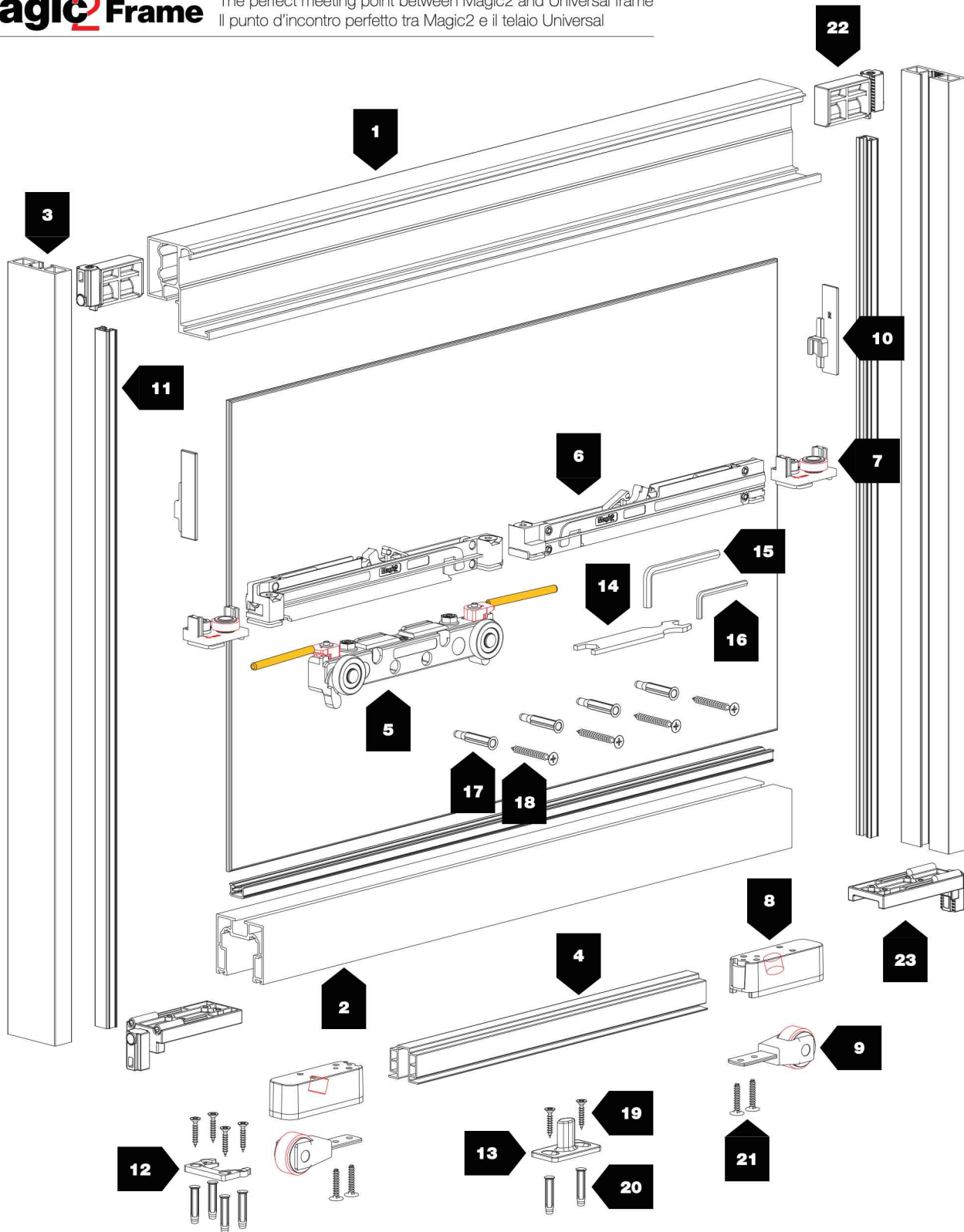

1100 - 1500 mm



80 kg



10 mm

COLORS / COLORI



Brushed Anodized
Silver
Argento Spazzolato



Brushed Anodized
Nickel
Nichel Spazzolato













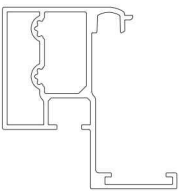
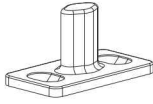
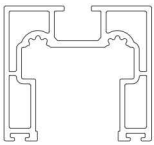
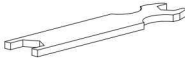

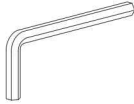
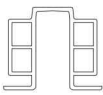

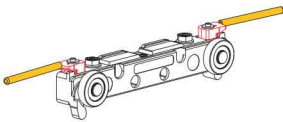

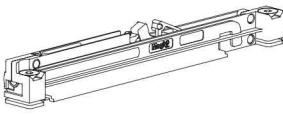

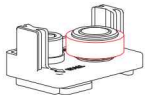
Brushed Anodized
Graphite
Grafite Spazzolato

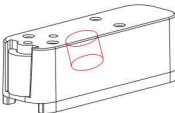

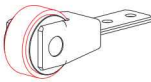
Brushed Anodized
Dark Brown
E3 Spazzolato

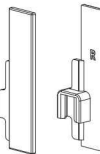
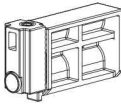

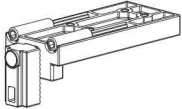
Brushed Anodized
Black
Nero Spazzolato

N°	Barcode	Image	kg		N°	Barcode	Image	kg	
1	2780		—		13	2855		—	
2	2778		—		14	1025		—	
3	2761		—		15	538		—	
4	2860		—		16	654		—	
5	2852		80		17	FISCHER UX6		—	
6	2864-80		80		18	4,5x40		—	
7	2856		—		19	4x30		—	
8	2858		80		20	FISCHER SX5		—	
9	2857		80		21	4x20		—	
10	2899		—		22	2774_DX 2774_SX		80	
11	2766		—		23	2776		80	
12	2859		—						

 **80 kg**

 N.2 Soft damper stoppers
N.2 Fermi ammortizzati

 Customizable door width
Larghezza porta personalizzabile

 Patented system
Sistema brevettato

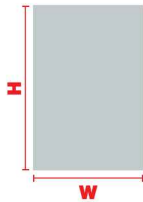
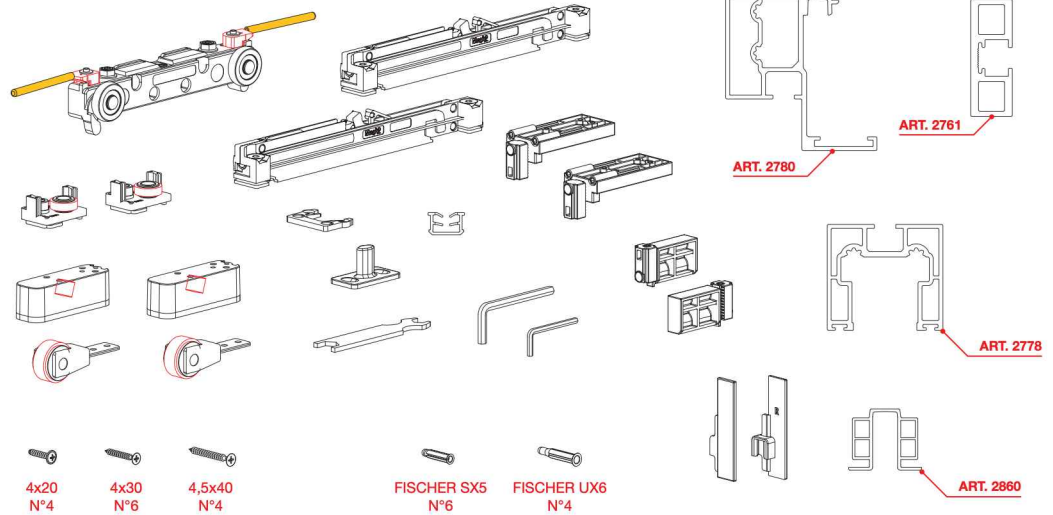

W	H	CODE	COLOURS / COLORI					
			AS	NKS	GRFS	E3S	NS	
1100 mm	2200 mm	K.0462.1.1 <input type="checkbox"/>	.02	.17	.25	.13	.15	1x
	2600 mm	K.0462.1.2 <input type="checkbox"/>	.02	.17	.25	.13	.15	1x
	3000 mm	K.0462.1.3 <input type="checkbox"/>	.02	.17	.25	.13	.15	1x
1500 mm	2200 mm	K.0461.1.1 <input type="checkbox"/>	.02	.17	.25	.13	.15	1x
	2600 mm	K.0461.1.2 <input type="checkbox"/>	.02	.17	.25	.13	.15	1x
	3000 mm	K.0461.1.3 <input type="checkbox"/>	.02	.17	.25	.13	.15	1x

MEASUREMENTS DESCRIPTION / DESCRIZIONE MISURE

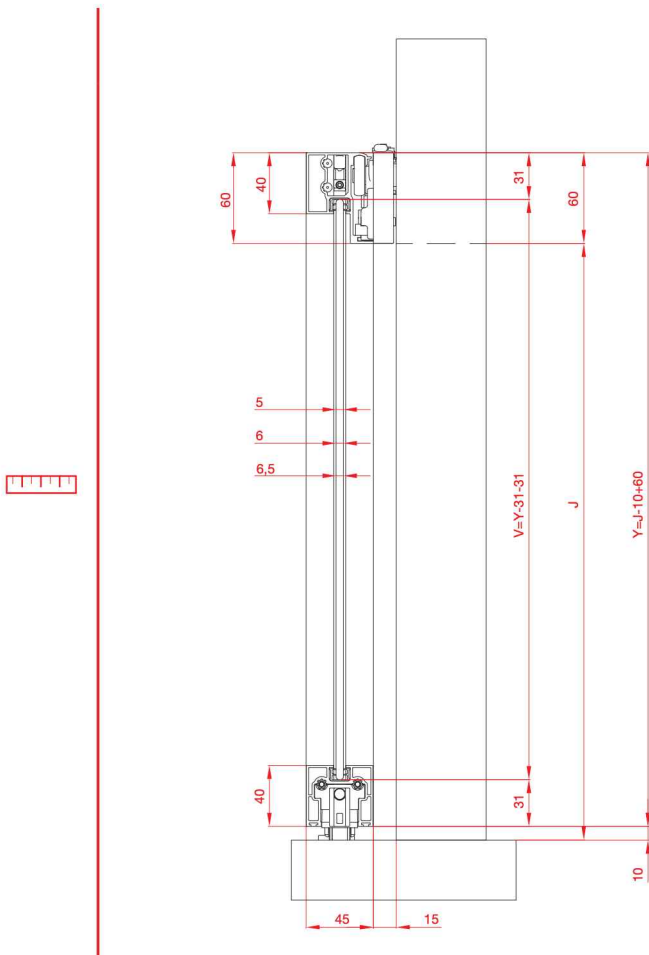

GLASS SIZE CALCULATION TABLE / CALCOLO VETRO

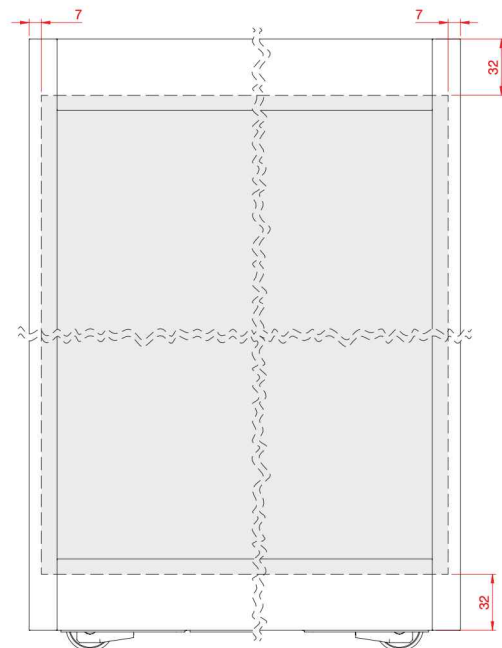

ACCESSORIES PLACEMENT (INTERMEDIATE POSITION) / POSIZIONAMENTO DEGLI ACCESSORI (POSIZIONE INTERMEDIA)



LEFT OPENING / APERTURA VERSO SINISTRA

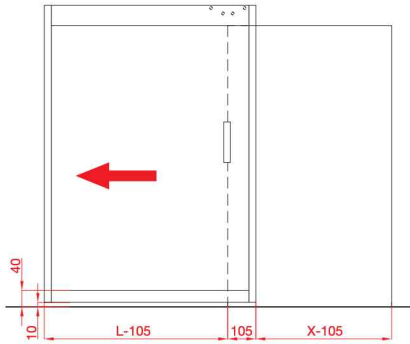

RIGHT OPENING / APERTURA VERSO DESTRA

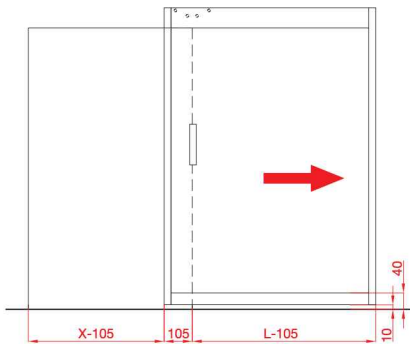

X = Min. 733 mm (L = 850)
X = Max. 1383 mm (L = 1500)

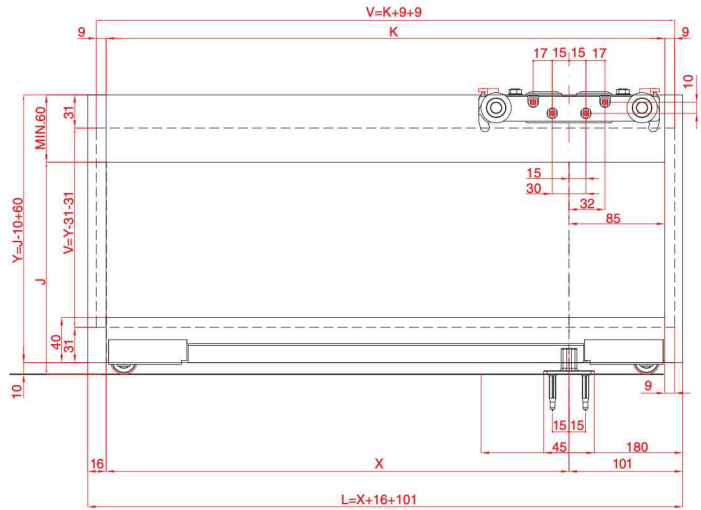

ACCESSORIES PLACEMENT (TOTAL OPENING POSITION) / POSIZIONAMENTO DEGLI ACCESSORI (POSIZIONE APERTURA TOTALE)



LEFT OPENING / APERTURA VERSO SINISTRA

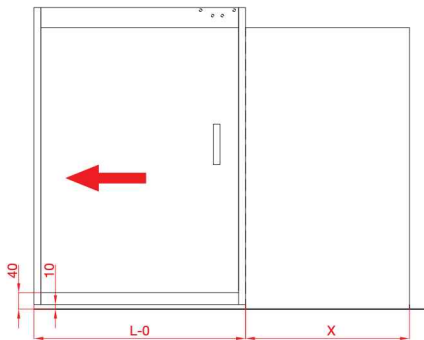

RIGHT OPENING / APERTURA VERSO DESTRA

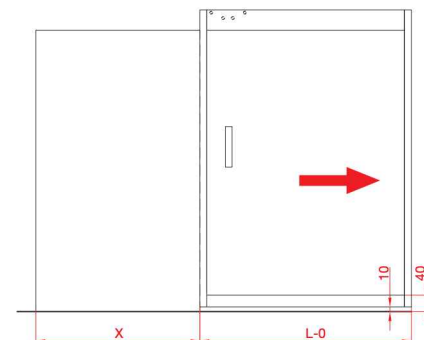

X = Min. 632 mm (L = 850)
X = Max. 1282 mm (L = 1500)

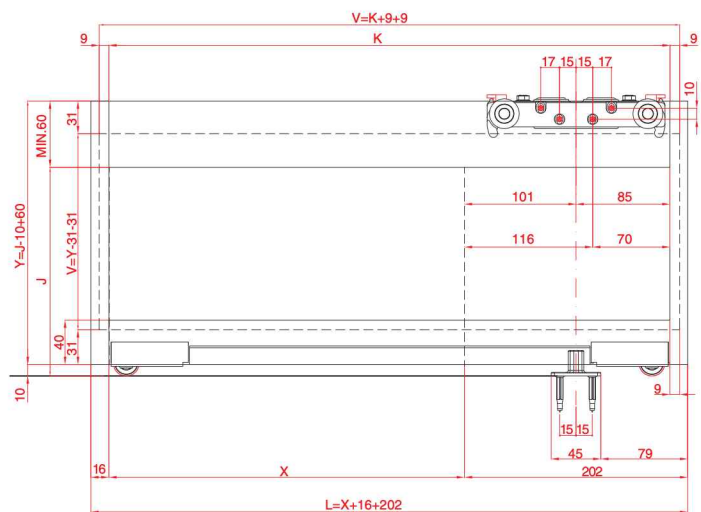

ART. 2859 - END STOPPER / FINE CORSA

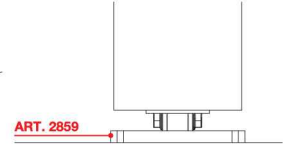
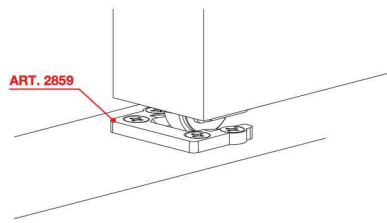
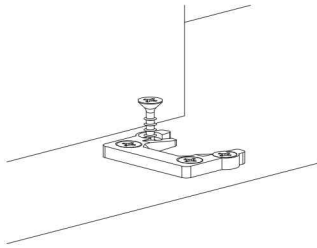

ALUMINIUM TRACK FOR IRREGULAR FLOOR PROFILO IN ALLUMINIO PER PAVIMENTAZIONE IRREGOLARE

OPTIONAL

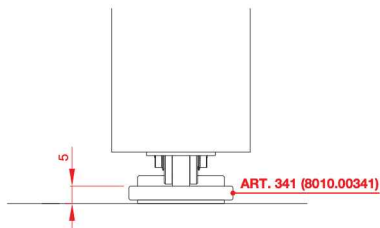
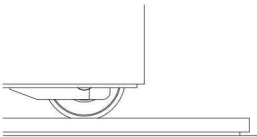

ALUMINIUM PROFILE
PROFILO IN ALLUMINIO

ART. 341
(8010.00341)

ADHESIVE / ADESIVO

ART. 341
8 01 0 .00341



Milcasa Store

www.milcasastore.com
support@milcasastore.com

(888) MILCASA
(888) 645-2272