

WING - WINGY - WING A4

INSTALLATION MANUAL



C20/25



S235



CLT/GL24H



EN 795:2012 A
CEN/TS 16415:2013
UNI 11578:2015 A



ANSI Z359.18/A

EN
795:2012
A

CEN/TS
16415:2013

UNI
11578:2015
A

ANSI
Z359.18/A



x1

INCLUDED IN THE PACKAGE

SAFETY REGULATION

- IT** L'installazione e/o utilizzo del prodotto Rotho Blaas è permessa solo a personale esperto previa lettura e comprensione del **1** **MANUALE D'INSTALLAZIONE** e delle **2** **NORME DI SICUREZZA** nella lingua del relativo Paese di utilizzo.
- DE** Die Installation und/oder die Verwendung des Produkts von Rotho Blaas ist ausschließlich Fachpersonal vorbehalten, nachdem es das **1** **INSTALLATIONS-HANDBUCH** und die **2** **SICHERHEITSVORSCHRIFTEN** in der Sprache des Verwendungslandes gelesen und verstanden hat.
- EN** Only qualified personnel may install and/or use this Rotho Blaas product, after reading and understanding the **1** **INSTALLATION MANUAL** and the **2** **SAFETY REGULATIONS**, in the language of the country of use.
- ES** La instalación y/o el uso del producto Rotho Blaas solo están permitidos al personal experto después de haber leído y comprendido el **1** **MANUAL DE INSTALACIÓN** y las **2** **NORMAS DE SEGURIDAD** en el idioma del país en el que se utiliza.
- FR** Seul le personnel expérimenté peut installer et/ou utiliser ce produit Rotho Blaas, après avoir lu et compris le **1** **MANUEL D'INSTALLATION** et les **2** **NORMES DE SÉCURITÉ** dans la langue du pays où le produit est utilisé.
- PT** A instalação e/ou utilização do produto RothoBlaas só é permitida a pessoal especializado após a leitura e compreensão do **1** **INFORMAÇÕES NECESSÁRIAS** e das **2** **NORMAS DE SEGURANÇA** na língua do respetivo país onde será utilizado.
- RU** К установке и (или) использованию продукции Rotho Blaas допускается только высококвалифицированный персонал после обязательного прочтения и усвоения **1** **РУКОВОДСТВО ПО УСТАНОВКЕ** и **2** **ПРАВИЛ ТЕХНИКИ БЕЗОПАСНОСТИ** на языке соответствующей страны использования.
- CS** Instalace a/nebo použití výrobku Rotho Blaas je povoleno pouze odborným osobám po přečtení a pochopení **1** **NÁVODU K INSTALACI** a **2** **BEZPEČNOSTNÍCH PŘEDPISŮ** v jazyce příslušné země použití.
- DA** Kun kvalificeret personale må installere og/eller bruge dette Rotho Blaas-produkt efter at have læst og forstået den **1** **INSTALLATIONSMANUALEN** og **2** **SIKKERHEDSFORSKRIFTERNE** på brugerens sprog.
- EL** Η εγκατάσταση ή/και η χρήση του προϊόντος Rotho Blaas επιτρέπεται μόνο σε έμπειρο προσωπικό που έχει διαβάσει και κατανοήσει τις **1** **ΕΓΧΕΙΡΙΔΙΟ ΕΓΚΑΤΑΣΤΑΣΗΣ** και τους **2** **ΚΑΝΟΝΙΣΜΟΥΣ ΑΣΦΑΛΕΙΑΣ** στη γλώσσα της σχετικής χώρας χρήσης.
- ET** Antud Rotho Blaasi toodet tohib paigaldada ja / või kasutada ainult kvalifitseeritud personal, kes on lugenud kasutamise riigi keeles **1** **PAIGALDUSJUHENDIS** ja **2** **OHUTUSEESKIRJU** ning nendest aru saanud.
- FI** Tämän Rotho Blaas -tuotteen asennus ja/tai käyttö on sallittu vain asiantuntevan henkilöstön toimesta sen jälkeen, kun he ovat lukeneet ja ymmärtäneet **1** **ASENNUSOHJEIDEN** ja **2** **TURVALLISUUSMÄÄRÄYKSET** käyttömaan kielellä.
- HR** Postavljanje i/ili uporaba proizvoda Rotho Blaas dopuštena je samo stručnom osoblju koje je prethodno pročitao i razumjelo **1** **UPUTA ZA MONTAŽU** kao i **2** **PROPISE O SIGURNOSTI** na jeziku zemlje uporabe.



+



SAFETY REGULATION

- HU** A Rotho Blaas termékét kizárólag hozzáértő személyzet szerelheti be és/vagy használhatja, az adott országnak megfelelő nyelvű **1 TELEPÍTÉSI KÉZIKÖNYV** és **2 BIZTONSÁGI SZABÁLYOK** elolvasása és megértése után.
- IS** Aðeins þjálfað starfsfólk má setja upp og/eða nota þessa Rotho Blaas-vöru eftir að hafa lesið og skilið **1 UPPSETNINGARHANDBÓKAR** og **2 REGLUGERÐIR UM ÖRYGGI** á tungumáli þess lands sem varan er notuð í.
- LT** Produktą „Rotho Blaas“ montuoti ir (arba) naudoti leidžiama tik patyrusiam personalui, prieš tai perskaicius ir supratus **1 MONTAVIMO VADOVE** ir **2 SAUGOS TAISYKLES** atitinkamos šalies, kurioje eksploatuojama, kalba.
- LV** Rotho Blaas produkta uzstādīšana un/vai lietošana ir atļauta tikai pieredzējušam darbiniekam pēc **1 UZSTĀDĪŠANAS ROKASGRĀMATĀ** un **2 DROŠĪBAS NOTEIKUMU** izlasīšanas un izpratnes attiecīgās valsts valodā, kurā produkts tiks lietots.
- NL** De installatie en/of het gebruik van het product Rotho Blaas is voorbehouden aan uitsluitend vakbekwaam personeel dat de **1 INSTALLATIEHANDLEIDING** en de **2 VEILIGHEIDSVOORSCHRIFTEN** in de taal van het land van gebruik gelezen en begrepen heeft.
- NO** Dette Rotho Blaas-produktet skal bare installeres og/eller brukes av kvalifisert personell som har lest og forstått **1 INSTALLASJONSHÅNDBOKEN** og **2 SIKKERHETSFORSKRIFTENE**, på det språket som brukes i landet produktet anvendes.
- PL** Instalacji i/lub użytkowania produktu Rotho Blaas może dokonać wyłącznie doświadczeni personel, który przeczytał i zrozumiał **1 MANUAL DE INSTALAÇÃO** oraz normy **2 BEZPIECZEŃSTWA** w języku kraju użytkowania.
- RO** Instalarea și/sau utilizarea produsului Rotho Blaas este permisă numai personalului expert, după ce a citit și înțeles **1 MANUALUL DE INSTALARE** și **2 NORMELE DE SIGURANȚĂ** în limba țării de utilizare a produsului.
- SK** Inštalácia a/alebo používanie produktu Rotho Blaas je povolené len skúsenému personálu po predchádzajúcom prečítaní a pochopení **1 NÁVODE NA INŠTALÁCIU** a **2 BEZPEČNOSTNÝCH NORIEM** v jazyku príslušnej krajiny používania.
- SL** Ta proizvod Rotho Blaas lahko namesti in/ali uporablja samo izkušeno osebe, ki je prebralo in razume vse **1 NAVODILIH ZA VGRADNJO** in **2 VARNOSTNE PREDPISE** v jeziku države njegove uporabe.
- SV** Endast erfaren personal får installera och/eller använda den här Rotho Blaas-produkten efter att **1 INSTALLATIONSANVISNINGARNA** och **2 SÄKERHETSFÖRESKRIFTER** har lästs igenom på språket i installationslandet.
- TR** Sadece yetkili personel, **1 KURULUM KILAVUZUNDA** ve **2 GÜVENLİK MEVZUATINI** (2) ürünü'n kullanıldığı ülke dilinde okuyup anladıktan sonra Rotho Blaas ürünü'nü kurabilir ve/veya kullanabilir.
- JA** Rotho Blaas製品の施工および使用は、資格を有する専門家のみに許可されています。施工および使用前に、必ず使用する国の言語で**1設置マニュアル**と**2安全規則**をお読み下さい。
- ZH** 只有具备合格资质的人员在阅读并理解以使用国的语言编写的**1安装手册**和**2安全规程**后才能安装和/或使用该Rotho Blaas产品。
- AR** يمكن فقط للفنيين المؤهلين باستخدام أو تركيب منتج Rotho Blaas بعد قراءة وفهم دليل التثبيت **1** نظم السلامة **2** بلغة البلد المستخدم فيها المنتج

**1**

+

**2**

TOOLS

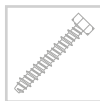
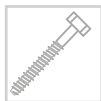
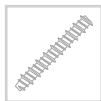
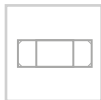
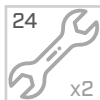

⁰¹ VINYLESTER CHEMICAL
ANCHOR WITHOUT STYRENE

INFORMATION

Type

Rothoblaas

WING - WINGY - WING A4

Related standard(s)

EN 795:2012 A

CEN/TS 16415:2013

UNI 11578:2015 A

ANSI Z359.18/A

Maximum number of users

3/1 user(s)

Name or logo of manufacturer/distributor

ROTHOBLAAS

Serial number and year of manufacture

YYXXXXX (YY = year - XXXX = lot number)

MBS (Minimum Breaking Strength)

22,2 kN

T_{min} (Minimum service temperature)

-20°

PRODUCT INFORMATIONS



EN 795:2012 A
CEN/TS 16415:2013
UNI 11578:2015 A



ANSI Z359.18 A

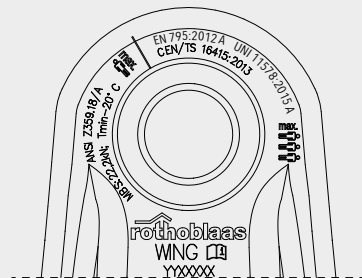
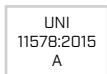
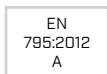
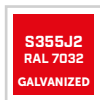
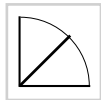

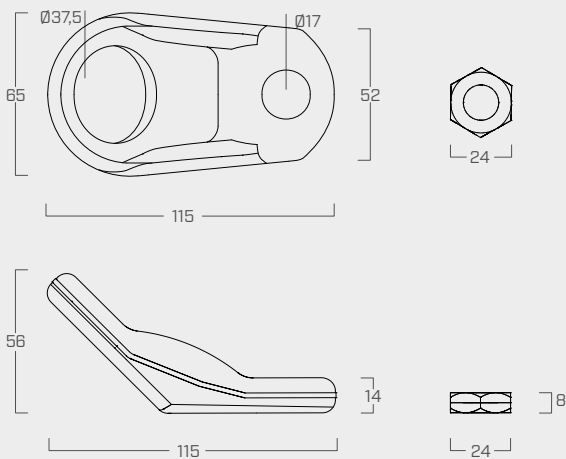

WING - WINGY - WING A4 DIMENSIONS



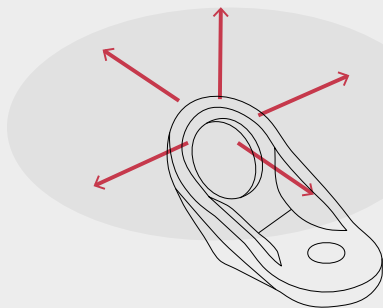

LOAD TEST MODEL



WING - WINGY SUBSTRUCTURES

		EN 795/A:2012 + CEN/TS 16415:2013 UNI 11578/A:2015	ANSI Z359.18/A
 C20/25	AB1	✓	✗
	VIN-FIX PRO	✓	✓
	SKRCE	✓	✗
 S235	M16 8.8	✓	✓
 CLT/GL24H	CLT MGS	✓	✗
	GL24h XEPOX+VGS	✓	✗

WING A4 SUBSTRUCTURES

		EN 795/A:2012 + CEN/TS 16415:2013 UNI 11578/A:2015	ANSI Z359.18/A
 C20/25	AB1 A4	✓	✗
	VIN-FIX PRO	✓	✓
 S235	M16 A2/A4	✓	✓
 CLT/GL24H		✗	✗

WING - WINGY - WING A4 CONCRETE SUBSTRUCTURE

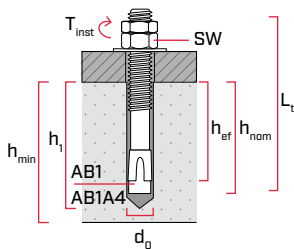
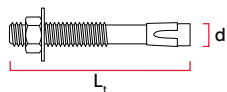
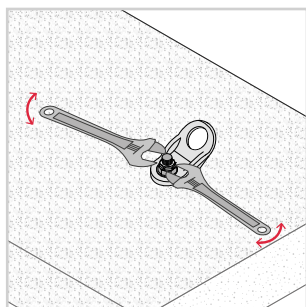
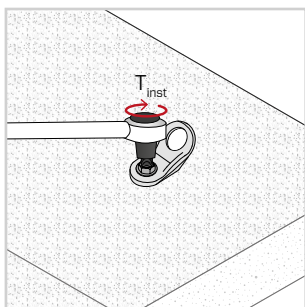
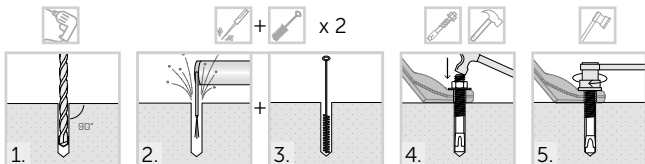

AB1

$d = d_0 = M16$	$h_{ef} = 85 \text{ mm}$
$L_t = 145 \text{ mm}$	SW = 24 mm
$h_1 \geq 105 \text{ mm}$	$T_{inst} = 100 \text{ Nm}$
$h_{nom} = 97 \text{ mm}$	$h_{min} \geq 170 \text{ mm}$

AB1A4

$d = d_0 = M16$	$h_{ef} = 85 \text{ mm}$
$L_t = 138 \text{ mm}$	SW = 24 mm
$h_1 \geq 110 \text{ mm}$	$T_{inst} = 120 \text{ Nm}$
$h_{nom} = 96 \text{ mm}$	$h_{min} \geq 170 \text{ mm}$

WING - WINGY - WING A4 CONCRETE SUBSTRUCTURE

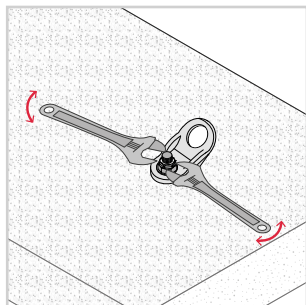
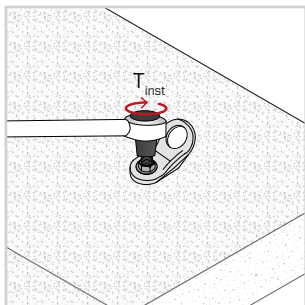
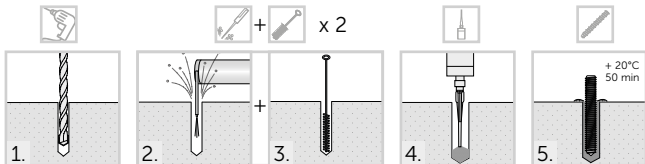

M16 - 8.8 min/A2

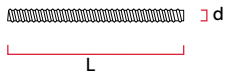
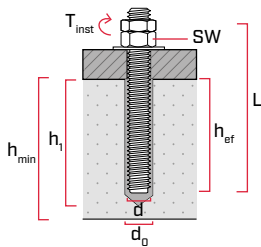

$$128 \leq h_{ef} \leq 320 \text{ mm}$$

$$h_{min} \geq h_{ef} + 30 \text{ mm}$$

$$L \geq h_{ef} + 40 \text{ mm}$$

$$h_{min} \geq 158 \text{ mm} \quad | \quad SW = 24 \text{ mm}$$

$$d_0 = 18 \text{ mm} \quad | \quad T_{inst} = 80 \text{ Nm}$$

$$d = 16 \text{ mm}$$

WING - WINGY CONCRETE SUBSTRUCTURE



C20/25



SKR CE

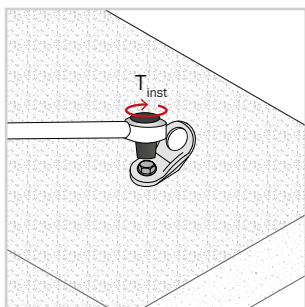
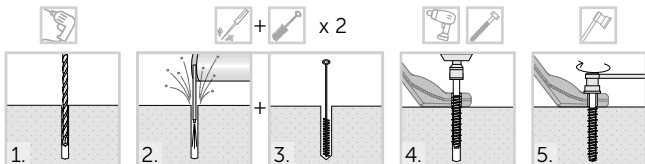

SKR CE

SKR CE 16 x 130 mm

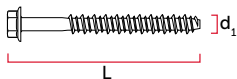
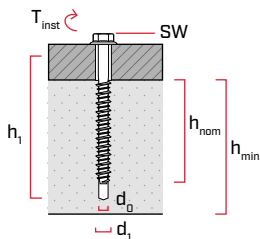

$h_1 \geq 140 \text{ mm}$	$d_1 = 16 \text{ mm}$
$d_0 = 14 \text{ mm}$	$SW = 21 \text{ mm}$
$h_{\min} \geq 170 \text{ mm}$	$T_{\text{inst}} = 160 \text{ Nm}$
$L = 130 \text{ mm}$	$h_{\text{nom}} \geq 110 \text{ mm}$

WING - WINGY - WING A4
STEEL SUBSTRUCTURE

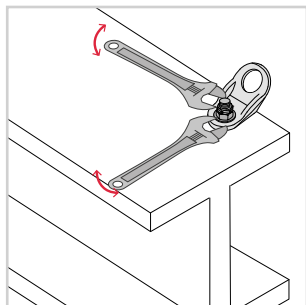
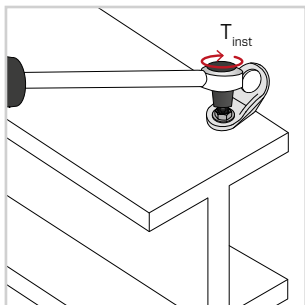
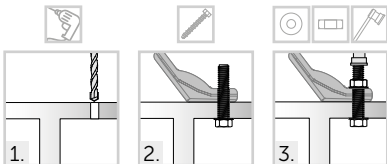

M16 - 8.8 min/A2-A4

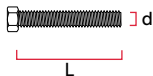
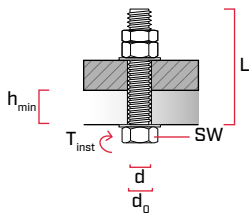

$d = 16 \text{ mm}$	$SW = 24 \text{ mm}$
$d_0 = 16,5 \text{ mm}$	$8.8 \rightarrow T_{inst} = 230 \text{ Nm}$
$L \geq 50 \text{ mm}$	$A2-A4 \rightarrow T_{inst} = 120 \text{ Nm}$
$L \geq h_{min} + 38 \text{ mm}$	
$h_{min} \geq 5 \text{ mm}$	

WING - WINGY
WOOD SUBSTRUCTURE

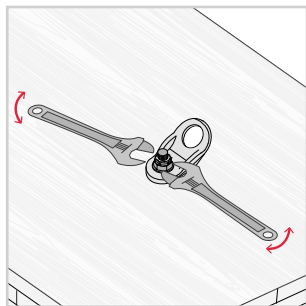
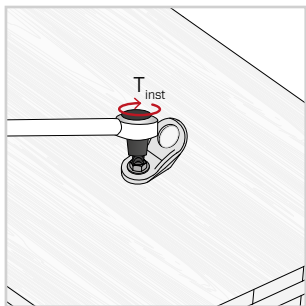
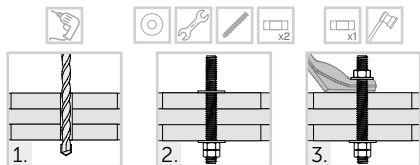

M16 - 8.8 min

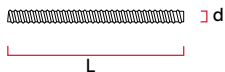
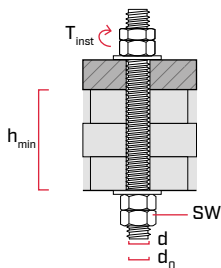

d	=	16 mm	SW	=	24 mm
d_0	=	16 mm	T_{inst}	=	100 Nm
L	\geq	$h_{min} + 60$ mm			
h_{min}	\geq	100 mm			

WING - WINGY

WOOD SUBSTRUCTURE

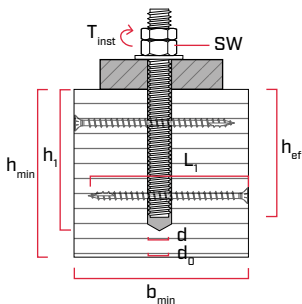
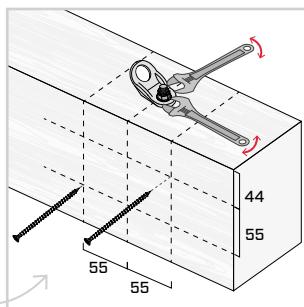
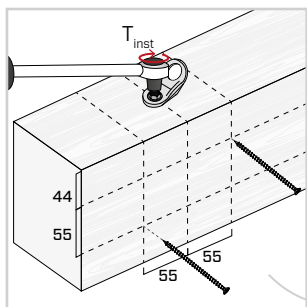
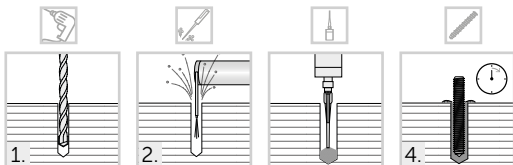

M16 - 8.8 min



VGS 11 x L₁ mm

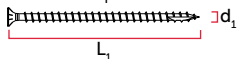

$h_{min} \geq 160 \text{ mm}$	$L \geq 175 \text{ mm}$
$b_{min} \geq 100 \text{ mm}$	$L \geq h_{ef} + 40 \text{ mm}$
$d = 16 \text{ mm}$	$L_1 \geq 100 \text{ mm}$
$d_o = 20 \text{ mm}$	$L_1 \leq b_{min}$
$h_{ef} \geq 130 \text{ mm}$	$SW = 24 \text{ mm}$
$h_1 = h_{ef} + 5 \text{ mm}$	$T_{inst} = 100 \text{ Nm}$



Rotho Blaas SRL

07-20

Via dell'Adige N.2/1 | 39040, Cortaccia (BZ) | Italia
Tel: +39 0471 81 84 00 | Fax: +39 0471 81 84 84
info@rothoblaas.com | www.rothoblaas.com

