

THE SOLID WEDGE SERIES REPRESENTS AN INNOVATIVE APPROACH TO CREATE A SIGNIFICANTLY HIGHER THERMAL PERFORMANCE FOR PRINTED CIRCUIT BOARDS WITH LARGE THERMAL LOADS IN CONDUCTION COOLED APPLICATIONS.

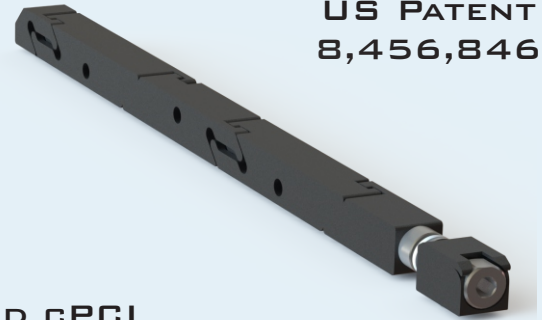

US PATENT
8,456,846

OPTIMIZED FOR VITA 48.2 AND GPCI

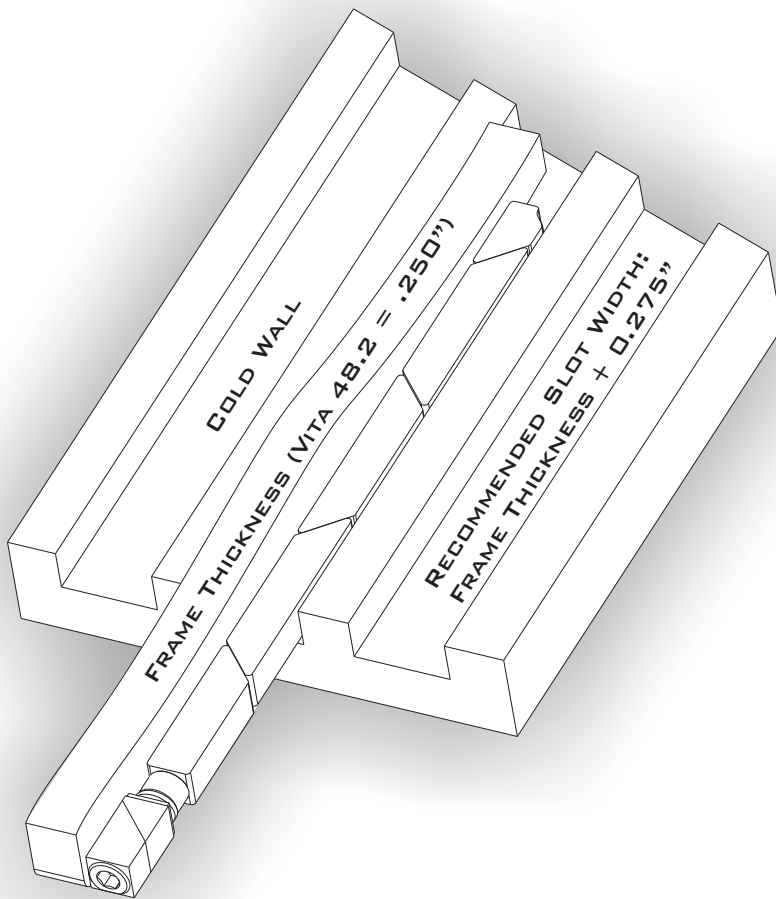

THERMAL RESISTANCE:

SW7-475-250-250 = 0.09°C/W
(RESISTANCE PER WEDGE LOCK)

FEATURES:

- SUPERIOR CLAMPING FORCE
- ZERO INSERTION FORCE
- LOW PROFILE DESIGN
- SELF RETRACTING SEGMENTS
- POSITIVE DRIVE SYSTEM
- LARGEST DRIVE SCREW AVAILABLE
- SUPERIOR PLATING ENDURANCE
- OPTIMIZED FOR VITA 48.2
- MODELS AVAILABLE FOR DOWNLOAD
- TORQUE TO 6-10 IN-LBS

MATERIALS:

ALUMINUM ALLOYS:

- ACTIVE WEDGE SEGMENTS 6061-T6

300 SERIES STAINLESS STEEL:

(PASSIVATED PER AMS - 2700)

- WASHERS
- ROUND NUT
- HEX DRIVE SCREW

THE SOLIDWEDGE DESIGN PROVIDES THREE TIMES THE THERMAL CONTACT AREA OF CONVENTIONAL WEDGE LOCKS. THE DESIGN ALSO FEATURES A LARGER SCREW SIZE WHICH CREATES HIGHER CONTACT FORCES BETWEEN THE HEAT FRAME AND COLD WALL SURFACES, WHICH SIGNIFICANTLY IMPROVES THERMAL PERFORMANCE.

THE INTERCONNECTED LINKS OF THE SOLIDWEDGE ALSO PROVIDE FOR A POSITIVE RETRACTION OF ALL SEGMENTS WITHOUT THE USE OF SPRINGS OR OTHER MECHANISMS.

PART NUMBER BUILDER

SW7 - 475 - 250 - 250 - XXX - XX - YY

<p>HEIGHT 0.250"</p> <p>WIDTH 0.250"</p> <p>HEX DRIVE</p> <p>FINISH</p> <p>OTHER OPTIONS</p> <p>4.75" MTG HOLE SPACING - <u>475</u></p> <p>7 ACTIVE SEGMENTS - <u>7</u></p> <p>SOLIDWEDGE - <u>SW</u></p>	<p>3/32" HEX KEY - <u>332</u></p> <p>2.5MM HEX KEY - <u>M25</u></p> <p>7/64" HEX KEY - <u>764</u></p>	<p>- <u>BV</u> - BELLEVILLE WASHERS</p> <p>- <u>NL</u> - NYLOK LOCK PATCH</p> <p>- <u>HC</u> - HELICOIL INSERTION</p>
	<p>BLACK ANODIZE PER MIL-A-8625, TYPE II, CLASS 2 - <u>BA</u></p> <p>HARD BLACK ANODIZE PER MIL-A-8625, TYPE III, CLASS 3 - <u>BH</u></p> <p>CHEMICAL FILM PER MIL-C-5541, CLASS 1A, CLEAR - <u>CC</u></p> <p>CHEMICAL FILM PER MIL-C-5541, CLASS 1A, GOLD, NON-ROHS - <u>CG</u></p> <p>ELECTROLESS NICKEL PER MIL-C-26074, CLASS 4, GRADE B, BRIGHT - <u>EN</u></p>	
	<p>X - REQUIRED VARIABLE</p> <p>Y - OPTIONAL VARIABLE</p> <p>EXAMPLE PART#'S:</p> <p>SW7-475-250-250-332-BH</p> <p>SW7-475-250-250-764-BA-BV</p>	

MOUNTING DETAILS

UNLESS OTHERWISE SPECIFIED

DIMENSIONS ARE IN INCHES.

TOLERANCES:
TWO PLACE DECIMAL: ±.01
THREE PLACE DECIMAL: ±.005

