

THE SOLID WEDGE SERIES REPRESENTS AN INNOVATIVE APPROACH TO CREATE A SIGNIFICANTLY HIGHER THERMAL PERFORMANCE FOR PRINTED CIRCUIT BOARDS WITH LARGE THERMAL LOADS IN CONDUCTION COOLED APPLICATIONS.

US PATENT
8,456,846

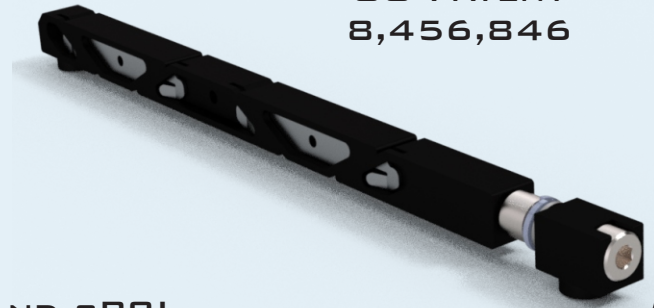

OPTIMIZED FOR VITA 48.2 AND GPCI

THERMAL RESISTANCE:

SW7-455-270-250-XXX-XX-30D-B075 = 0.09° C/W
(RESISTANCE PER WEDGE LOCK)

FEATURES:

- ~ 1600 LBS CLAMPING FORCE
- EXPANDED WITH HELICOIL INSERT
- ZERO INSERTION FORCE
- LOW PROFILE DESIGN
- SELF RETRACTING SEGMENTS
- POSITIVE DRIVE SYSTEM
- LARGEST DRIVE SCREW AVAILABLE
- SUPERIOR PLATING ENDURANCE
- OPTIMIZED FOR VITA 48.2
- MODELS AVAILABLE FOR DOWNLOAD
- TORQUE TO 6-10 IN-LBS

MATERIALS:

ALUMINUM ALLOY 6061-T6:

- WEDGES
- MOUNTING BLOCK

300 SERIES STAINLESS STEEL:

(PASSIVATED PER AMS - 2700)

- WASHERS
- ROUND NUT
- HEX DRIVE SCREW

HELICOIL WIRE INSERT

- NITRONIC 60

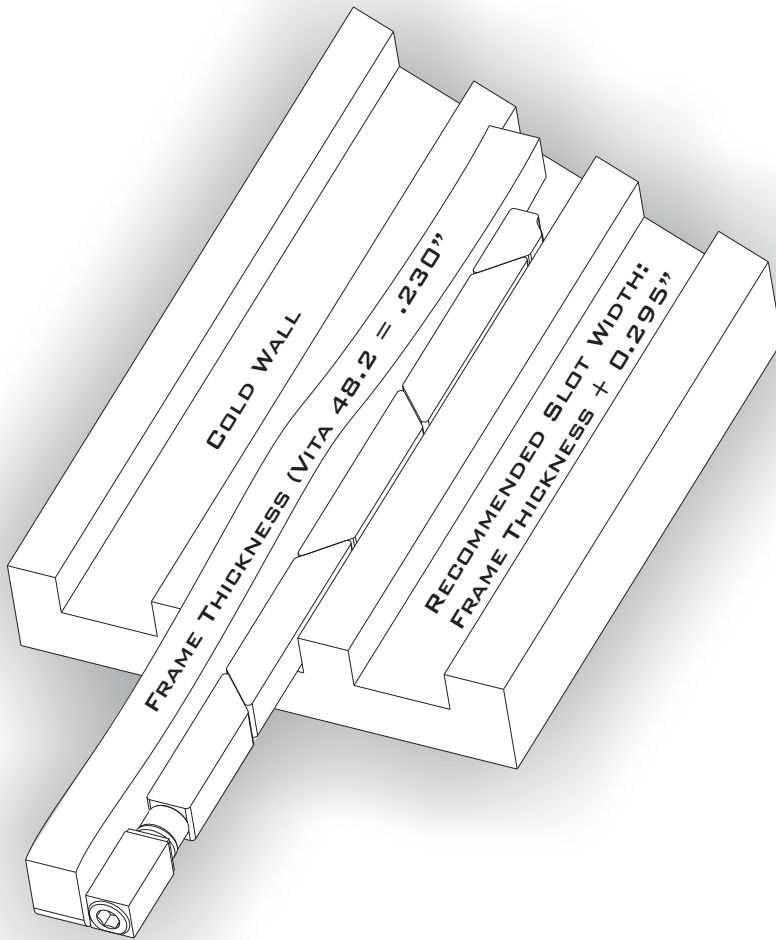

THE SOLIDWEDGE DESIGN PROVIDES THREE TIMES THE THERMAL CONTACT AREA OF CONVENTIONAL WEDGE LOCKS. THE DESIGN ALSO FEATURES A LARGER SCREW SIZE WHICH CREATES HIGHER CONTACT FORCES BETWEEN THE HEAT FRAME AND COLD WALL SURFACES, WHICH SIGNIFICANTLY IMPROVES THERMAL PERFORMANCE.

THE INTERCONNECTED LINKS OF THE SOLIDWEDGE ALSO PROVIDE FOR A POSITIVE RETRACTION OF ALL SEGMENTS WITHOUT THE USE OF SPRINGS OR OTHER MECHANISMS.

PART NUMBER BUILDER

SW7 - 455 - 270 - 250 - XXX - XX - 30D - B075 - YY

<p>4.55" MTG HOLE SPACING - 455</p> <p>7 ACTIVE SEGMENTS - 7</p> <p>SOLIDWEDGE - SW</p>	<p>HEIGHT 0.270"</p>	<p>WIDTH 0.250"</p>	<p>HEX DRIVE</p>	<p>FINISH</p>	<p>30° WEDGE SEGMENTS</p>	<p>BOSS LENGTH 0.075"</p>	<p>OTHER OPTIONS</p> <ul style="list-style-type: none"> - BV - BELLEVILLE WASHERS - NL - NYLOK LOCK PATCH
	<p>3/32" HEX KEY - 332 M2.5 HEX KEY - M25 7/64" HEX KEY - 764</p>						

BLACK ANODIZE PER MIL-A-8625, TYPE II, CLASS 2 - BA
 HARD BLACK ANODIZE PER MIL-A-8625, TYPE III, CLASS 2 - BH
 CHEMICAL FILM PER MIL-C-5541, CLASS 1A, CLEAR - CC
 CHEMICAL FILM PER MIL-C-5541, CLASS 1A, GOLD, NON-ROHS - CG
 ELECTROLESS NICKEL PER MIL-C-26074, CLASS 4, GRADE B, BRIGHT - EN

X - REQUIRED VARIABLE
Y - OPTIONAL VARIABLE

EXAMPLE PART#'S:
 SW7-455-270-250-332-BA-30D-B075
 SW7-455-270-250-764-BA-30D-B075-BV

MOUNTING DETAILS

UNLESS OTHERWISE SPECIFIED

DIMENSIONS ARE IN INCHES.

TOLERANCES:
 TWO PLACE DECIMAL: ±.01
 THREE PLACE DECIMAL: ±.005

EXPANSION DETAILS

NOMINAL EXPANSION: .025"

MAXIMUM EXPANSION: .060"

