

US PATENT
8,456,846

THE SOLIDWEDGE REPRESENTS AN INNOVATIVE APPROACH TO CREATE A SIGNIFICANTLY HIGHER CLAMPING FORCE AND IMPROVED THERMAL PERFORMANCE FOR PRINTED CIRCUIT BOARDS WITH LARGE THERMAL LOADS IN CONDUCTION COOLED APPLICATIONS.

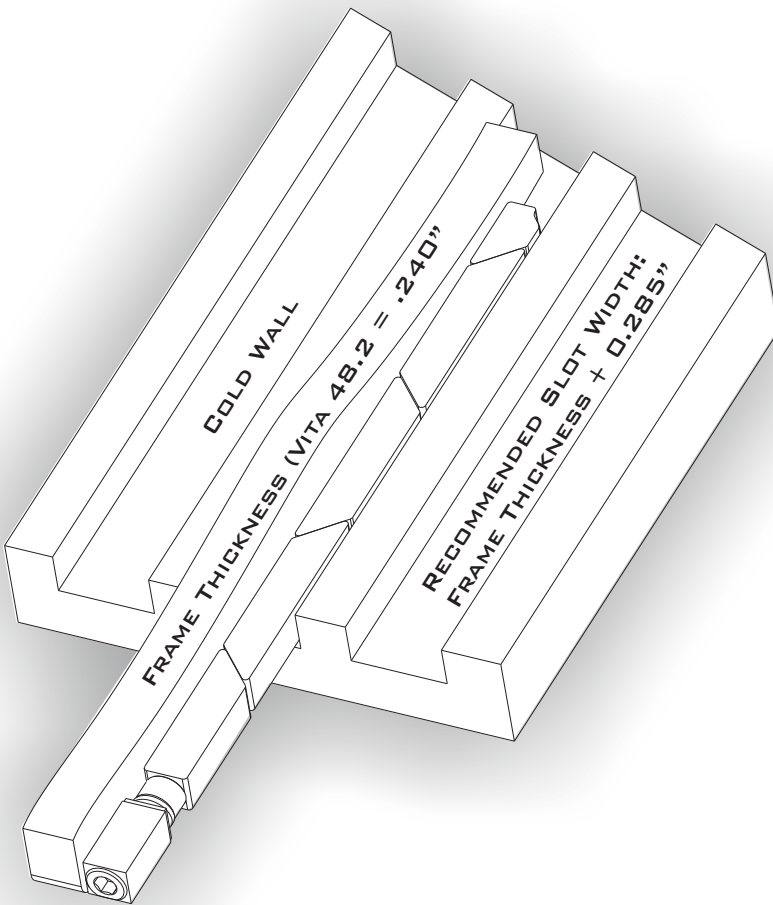

OPTIMIZED FOR VITA 48.2 AND cPCI



THERMAL RESISTANCE:

SW7-455-260-365-XXX-XX-B075 = 0.10°C/W
(RESISTANCE PER WEDGE LOCK)

FEATURES:

- ZERO INSERTION FORCE
- DEVICE REMAINS ASSEMBLED WHEN DISENGAGED FOR MODULE EXTRACTION
- POSITIVE RETRACTION DESIGN ELIMINATES RISK OF MECHANICAL JAMMING AND/OR BINDING
- LARGEST DRIVE SCREW AVAILABLE
- OPTIONAL HELICOIL DRIVE SCREW ASSEMBLY FOR EXTENDED HIGH PERFORMANCE AND LONGER LIFE
- MODELS AVAILABLE FOR DOWNLOAD
- TORQUE TO 6-10 IN-LBS

MATERIALS:

ALUMINUM ALLOYS:

- ACTIVE WEDGE SEGMENTS 6061-T6

300 SERIES STAINLESS STEEL:

(PASSIVATED PER AMS - 2700)

- WASHERS
- ROUND NUT
- HEX DRIVE SCREW

THE SOLIDWEDGE DESIGN PROVIDES THREE TIMES THE THERMAL CONTACT AREA OF CONVENTIONAL WEDGE LOCKS. THE DESIGN ALSO FEATURES A LARGER SCREW SIZE WHICH CREATES HIGHER CONTACT FORCES BETWEEN THE HEAT FRAME AND COLD WALL SURFACES, WHICH SIGNIFICANTLY IMPROVES THERMAL PERFORMANCE.

THE INTERCONNECTED LINKS OF THE SOLIDWEDGE ALSO PROVIDE FOR A POSITIVE

CONFIGURATION/PART NUMBER BUILDER

SW7 - 455 - 260 - 365 - XXX - XX - B075 - YY

<p>4.55" MTG HOLE SPACING - <u>455</u></p> <p><u>7</u> ACTIVE SEGMENTS - <u>7</u></p> <p>SOLIDWEDGE - <u>SW</u></p>	<p>HEIGHT <u>0.260"</u></p>	<p>WIDTH <u>0.365"</u></p>	<p>HEX DRIVE</p>	<p>FINISH</p>	<p>BOSS LENGTH <u>0.075"</u></p>	<p>OTHER OPTIONS</p> <ul style="list-style-type: none"> - <u>BV</u> - BELLEVILLE WASHERS - <u>NL</u> - NYLOK LOCK PATCH - <u>HC</u> - HELICOIL INSERTION
	<p>3/32" HEX KEY - <u>332</u> M2.5 HEX KEY - <u>M25</u> 7/64" HEX KEY - <u>764</u></p>					
	<p>BLACK ANODIZE PER MIL-A-8625, TYPE II, CLASS 2 - <u>BA</u> HARD BLACK ANODIZE PER MIL-A-8625, TYPE III, CLASS 2 - <u>BH</u> CHEMICAL FILM PER MIL-C-5541, CLASS 1A, CLEAR - <u>CC</u> CHEMICAL FILM PER MIL-C-5541, CLASS 1A, GOLD, NON-ROHS - <u>CG</u> ELECTROLESS NICKEL PER MIL-C-26074, CLASS 4, GRADE B, BRIGHT - <u>EN</u></p>					

X - REQUIRED VARIABLE
Y - OPTIONAL VARIABLE

EXAMPLE PART#'S:
SW7-455-260-365-332-BA-B075
SW7-455-260-365-764-BA-B075-BV

MOUNTING DETAILS

UNLESS OTHERWISE SPECIFIED
DIMENSIONS ARE IN INCHES.
TOLERANCES:
TWO PLACE DECIMAL: ±.01
THREE PLACE DECIMAL: ±.005

EXPANSION DETAILS

NOMINAL EXPANSION: .025"

MAXIMUM EXPANSION: .050"

