

THE SOLID WEDGE SERIES REPRESENTS AN INNOVATIVE APPROACH TO CREATE A SIGNIFICANTLY HIGHER THERMAL PERFORMANCE FOR PRINTED CIRCUIT BOARDS WITH LARGE THERMAL LOADS IN CONDUCTION COOLED APPLICATIONS.

OPTIMIZED FOR VITA 48.2 AND GPCI

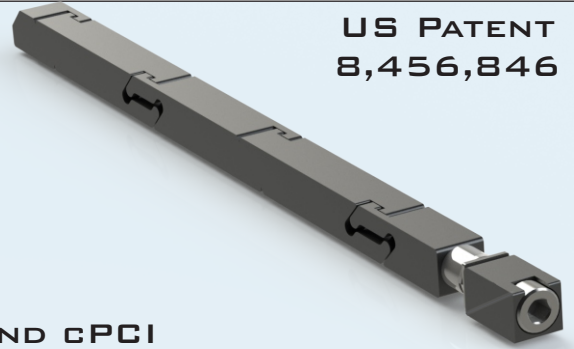

US PATENT
8,456,846

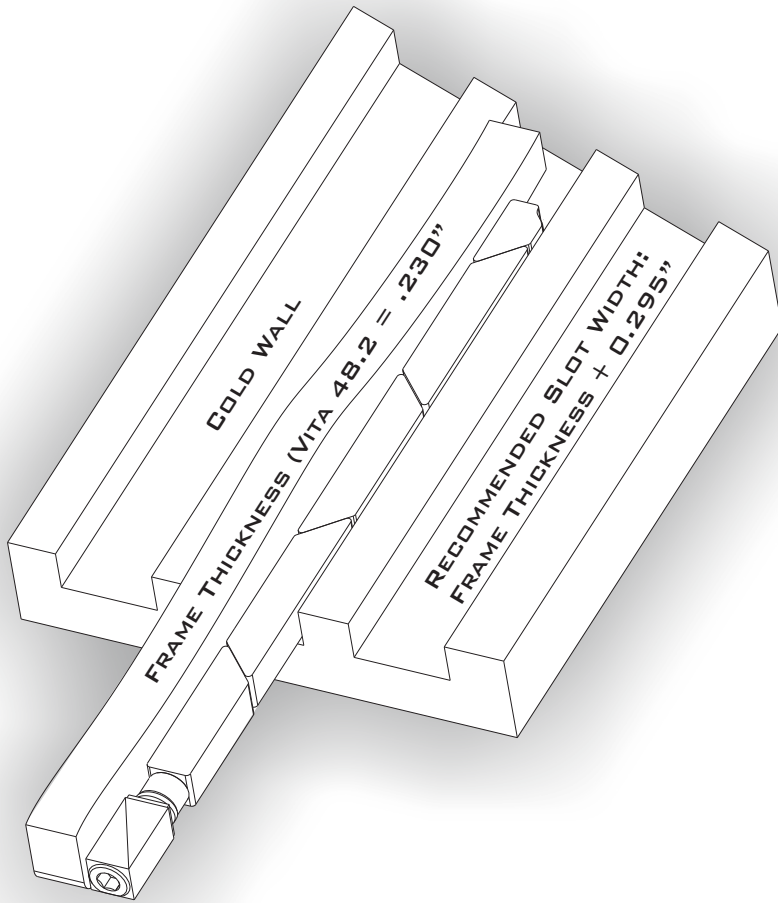

THERMAL RESISTANCE:

SW7-43-270-250 = 0.12 °C/W
(RESISTANCE PER WEDGE LOCK)

FEATURES:

- SUPERIOR CLAMPING FORCE
- ZERO INSERTION FORCE
- LOW PROFILE DESIGN
- SELF RETRACTING SEGMENTS
- POSITIVE DRIVE SYSTEM
- LARGEST DRIVE SCREW AVAILABLE
- SUPERIOR PLATING ENDURANCE
- OPTIMIZED FOR VITA 48.2
- MODELS AVAILABLE FOR DOWNLOAD
- TORQUE TO 6-10 IN-LBS

MATERIALS:

ALUMINUM ALLOYS:

- ACTIVE WEDGE SEGMENTS 6061-T6

300 SERIES STAINLESS STEEL:

(PASSIVATED PER AMS - 2700)

- WASHERS
- ROUND NUT
- HEX DRIVE SCREW

THE SOLIDWEDGE DESIGN PROVIDES THREE TIMES THE THERMAL CONTACT AREA OF CONVENTIONAL WEDGE LOCKS. THE DESIGN ALSO FEATURES A LARGER SCREW SIZE WHICH CREATES HIGHER CONTACT FORCES BETWEEN THE HEAT FRAME AND COLD WALL SURFACES, WHICH SIGNIFICANTLY IMPROVES THERMAL PERFORMANCE.

THE INTERCONNECTED LINKS OF THE SOLIDWEDGE ALSO PROVIDE FOR A POSITIVE RETRACTION OF ALL SEGMENTS WITHOUT THE USE OF SPRINGS OR OTHER MECHANISMS.

PART NUMBER BUILDER

SW7 - 43 - 270 - 250 - XXX - XX - YY

<p>4.0" MTG HOLE SPACING - <u>40</u></p> <p>7 ACTIVE SEGMENTS - <u>7</u></p> <p>SOLIDWEDGE - <u>SW</u></p>	<p>HEIGHT 0.270"</p>	<p>WIDTH 0.250"</p>	<p>HEX DRIVE</p>	<p>FINISH</p>	<p>OTHER OPTIONS</p>
	<p>3/32" HEX KEY - <u>332</u> 2.5MM HEX KEY - <u>M25</u> 7/64" HEX KEY - <u>764</u></p>			<p>- <u>BV</u> - BELLEVILLE WASHERS - <u>NL</u> - NYLOK LOCK PATCH - <u>HC</u> - HELICOIL INSERTION</p>	
	<p>BLACK ANODIZE PER MIL-A-8625, TYPE II, CLASS 2 - <u>BA</u> HARD BLACK ANODIZE PER MIL-A-8625, TYPE III, CLASS 3 - <u>BH</u> CHEMICAL FILM PER MIL-C-5541, CLASS 1A, CLEAR - <u>CC</u> CHEMICAL FILM PER MIL-C-5541, CLASS 1A, GOLD, NON-ROHS - <u>CG</u> ELECTROLESS NICKEL PER MIL-C-26074, CLASS 4, GRADE B, BRIGHT - <u>EN</u></p>				

X - REQUIRED VARIABLE
Y - OPTIONAL VARIABLE

EXAMPLE PART #'S:

SW7-43-270-250-332-BH
SW7-43-270-250-764-BA-BV

MOUNTING DETAILS

UNLESS OTHERWISE SPECIFIED

DIMENSIONS ARE IN INCHES.

TOLERANCES:
TWO PLACE DECIMAL: ±.01
THREE PLACE DECIMAL: ±.005

EXPANSION DETAILS

