

THE SOLID WEDGE SERIES REPRESENTS AN INNOVATIVE APPROACH TO CREATE A SIGNIFICANTLY HIGHER THERMAL PERFORMANCE FOR PRINTED CIRCUIT BOARDS WITH LARGE THERMAL LOADS IN CONDUCTION COOLED APPLICATIONS.

US PATENT
8,456,846

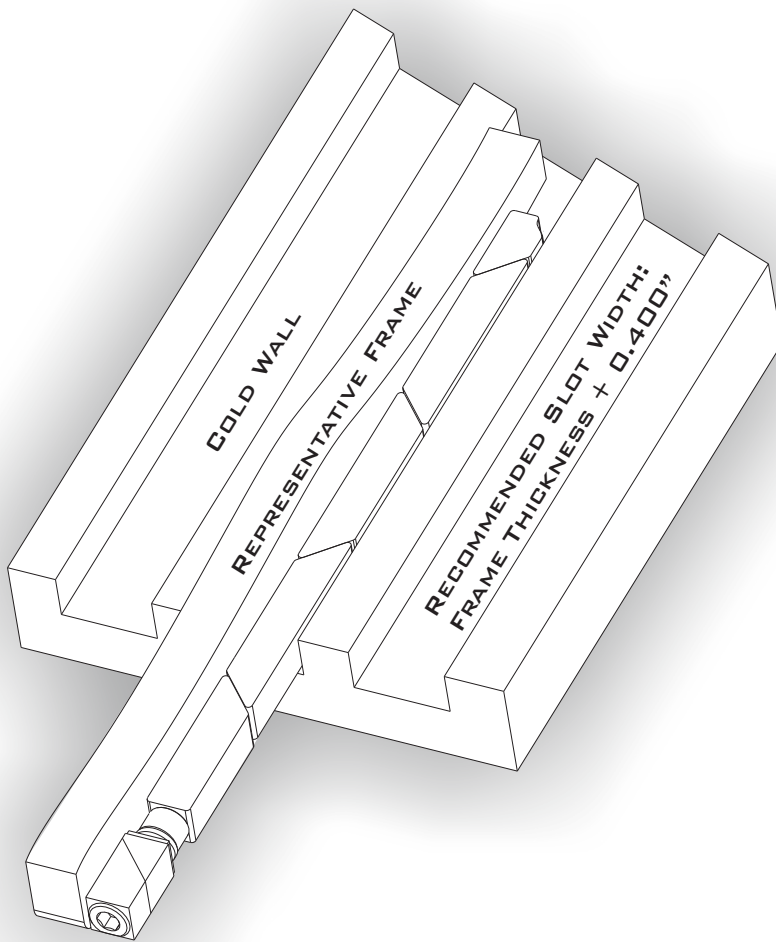
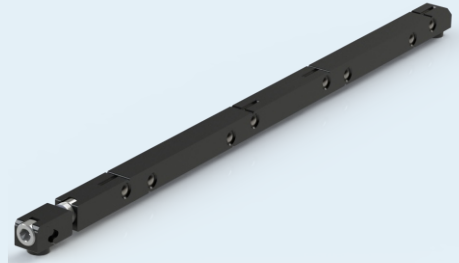

THERMAL RESISTANCE:

SW7-100-375-375 = 0.07°C/W
(RESISTANCE PER WEDGE LOCK)

FEATURES:

- SUPERIOR CLAMPING FORCE
- ZERO INSERTION FORCE
- SELF RETRACTING SEGMENTS
- POSITIVE DRIVE SYSTEM
- LARGEST DRIVE SCREW AVAILABLE
- SUPERIOR PLATING ENDURANCE
- MODELS AVAILABLE FOR DOWNLOAD
- TORQUE TO 15-30 IN-LBS
- HELICOIL INSERT FOR HIGHER SUSTAINED CLAMPING FORCE

MATERIALS:

ALUMINUM ALLOYS:

- ACTIVE WEDGES 6061-T6
- FRONT MOUNTING BLOCK 7075-T6

300 SERIES STAINLESS STEEL:

- (PASSIVATED PER AMS - 2700)
- WASHERS
- HEX DRIVE SCREW
- ROUND LOCKNUT

WIRE HELICOIL INSERT

- NITRONIC 60

THE SOLIDWEDGE DESIGN PROVIDES THREE TIMES THE THERMAL CONTACT AREA OF CONVENTIONAL WEDGE LOCKS. THE DESIGN ALSO FEATURES A LARGER SCREW SIZE WHICH CREATES HIGHER CONTACT FORCES BETWEEN THE HEAT FRAME AND COLD WALL SURFACES, WHICH SIGNIFICANTLY IMPROVES THERMAL PERFORMANCE.

THE INTERCONNECTED LINKS OF THE SOLIDWEDGE ALSO PROVIDE FOR A POSITIVE RETRACTION OF ALL SEGMENTS WITHOUT THE USE OF SPRINGS OR OTHER MECHANISMS.

PART NUMBER BUILDER

SW7 - 100 - 375 - 375 - XXX - XX - YY

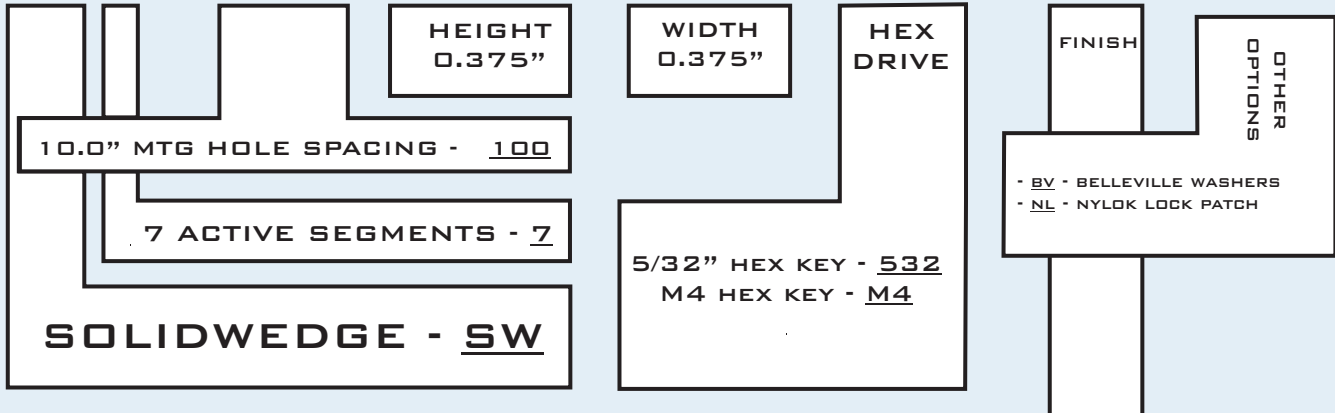

BLACK ANODIZE PER MIL-A-8625, TYPE II, CLASS 2 - BA
 HARD BLACK ANODIZE PER MIL-A-8625, TYPE III, CLASS 3 - BH
 CHEMICAL FILM PER MIL-C-5541, CLASS 1A, CLEAR - CC
 CHEMICAL FILM PER MIL-C-5541, CLASS 1A, GOLD, NON-ROHS - CG
 ELECTROLESS NICKEL PER MIL-C-26074, CLASS 4, GRADE B, BRIGHT - EN

X - REQUIRED VARIABLE
Y - OPTIONAL VARIABLE
 EXAMPLE PART#S:
 SW7-100-375-375-332-8H
 SW7-100-375-375-764-BA-BV

MOUNTING DETAILS

UNLESS OTHERWISE SPECIFIED
 DIMENSIONS ARE IN INCHES.
 TOLERANCES:
 TWO PLACE DECIMAL: ±.01
 THREE PLACE DECIMAL: ±.005

