

THE SOLID WEDGE SERIES REPRESENTS AN INNOVATIVE APPROACH TO CREATE A SIGNIFICANTLY HIGHER THERMAL PERFORMANCE FOR PRINTED CIRCUIT BOARDS WITH LARGE THERMAL LOADS IN CONDUCTION COOLED APPLICATIONS.

OPTIMIZED FOR VITA 48.2 AND GPCI

US PATENT  
8,456,846

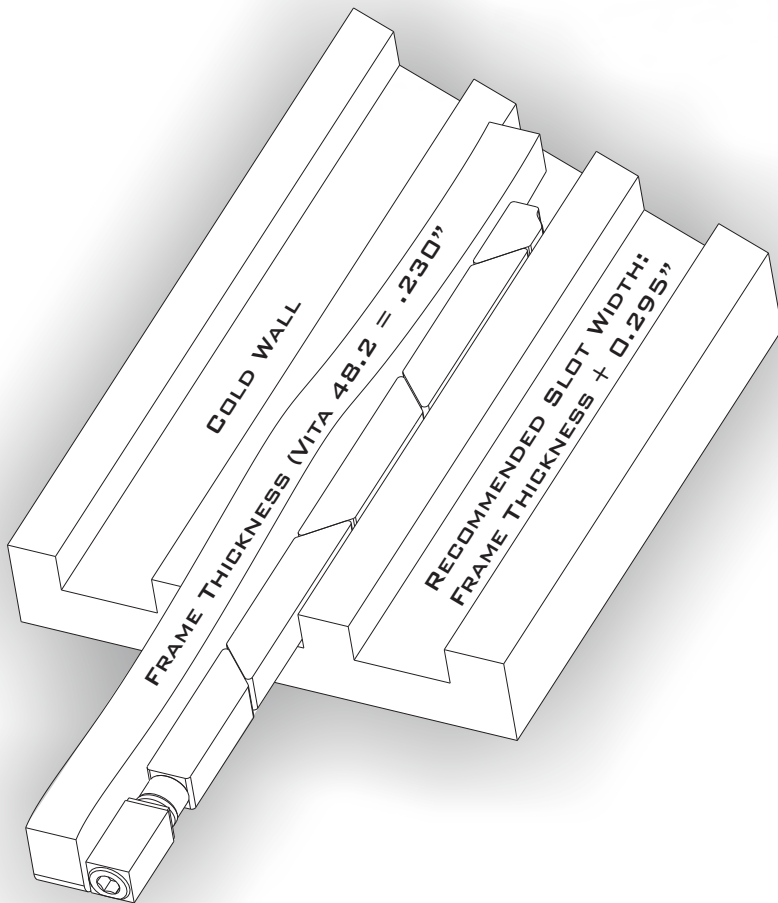
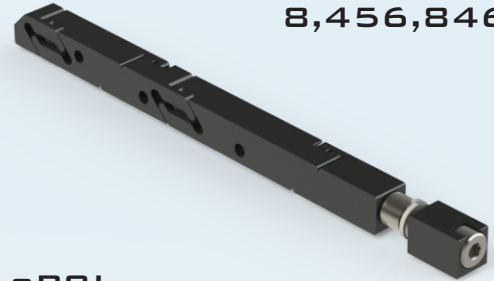

**THERMAL RESISTANCE:**

SW7-37-270-250 = 0.14°C/W  
(RESISTANCE PER WEDGE LOCK)

**FEATURES:**

- SUPERIOR CLAMPING FORCE
- ZERO INSERTION FORCE
- LOW PROFILE DESIGN
- SELF RETRACTING SEGMENTS
- POSITIVE DRIVE SYSTEM
- LARGEST DRIVE SCREW AVAILABLE
- SUPERIOR PLATING ENDURANCE
- OPTIMIZED FOR VITA 48.2
- MODELS AVAILABLE FOR DOWNLOAD
- TORQUE TO 6-10 IN-LBS

**MATERIALS:**

**ALUMINUM ALLOYS:**

- ACTIVE WEDGE SEGMENTS 6061-T6
- FRONT MOUNTING BLOCK 7075

**300 SERIES STAINLESS STEEL:**

(PASSIVATED PER AMS - 2700)

- WASHERS
- ROUND NUT
- HEX DRIVE SCREW

THE SOLIDWEDGE DESIGN PROVIDES THREE TIMES THE THERMAL CONTACT AREA OF CONVENTIONAL WEDGE LOCKS. THE DESIGN ALSO FEATURES A LARGER SCREW SIZE WHICH CREATES HIGHER CONTACT FORCES BETWEEN THE HEAT FRAME AND GOLD WALL SURFACES, WHICH SIGNIFICANTLY IMPROVES THERMAL PERFORMANCE.

THE INTERCONNECTED LINKS OF THE SOLIDWEDGE ALSO PROVIDE FOR A POSITIVE RETRACTION OF ALL SEGMENTS WITHOUT THE USE OF SPRINGS OR OTHER MECHANISMS.

## PART NUMBER BUILDER

SW5 - 37 - 270 - 250 - XXX - XX - YY

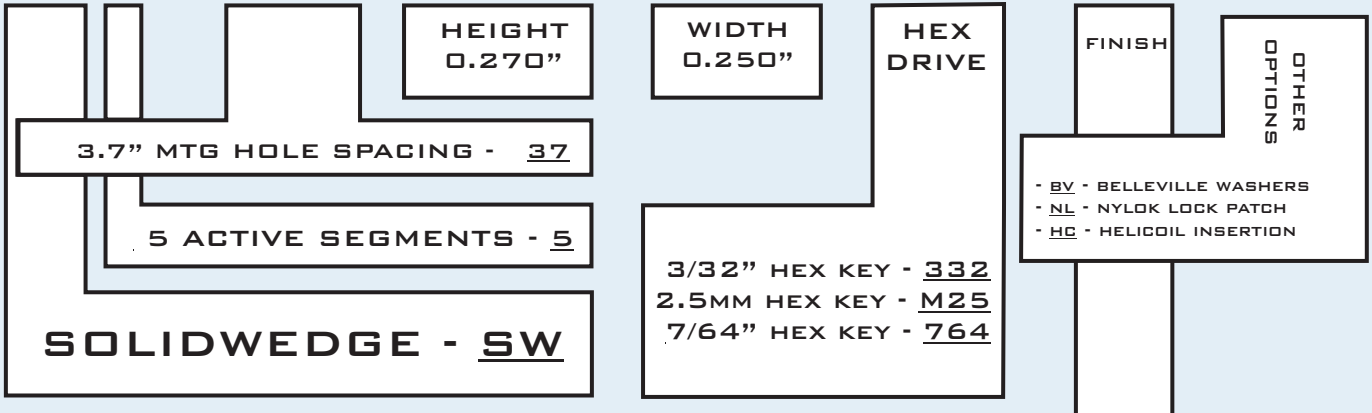

BLACK ANODIZE PER MIL-A-8625, TYPE II, CLASS 2 - BA  
HARD BLACK ANODIZE PER MIL-A-8625, TYPE III, CLASS 3 - BH  
CHEMICAL FILM PER MIL-C-5541, CLASS 1A, CLEAR - CC  
CHEMICAL FILM PER MIL-C-5541, CLASS 1A, GOLD, NON-ROHS - CG  
ELECTROLESS NICKEL PER MIL-C-26074, CLASS 4, GRADE B, BRIGHT - EN

X - REQUIRED VARIABLE  
Y - OPTIONAL VARIABLE  
EXAMPLE PART#'S:  
SW5-37-270-250-332-BH  
SW5-37-270-250-764-BA-BV

## MOUNTING DETAILS

UNLESS OTHERWISE SPECIFIED

DIMENSIONS ARE IN INCHES.

TOLERANCES:  
TWO PLACE DECIMAL: ±.01  
THREE PLACE DECIMAL: ±.005

