

TECHNICAL SPECIFICATIONS

Installation Diagram

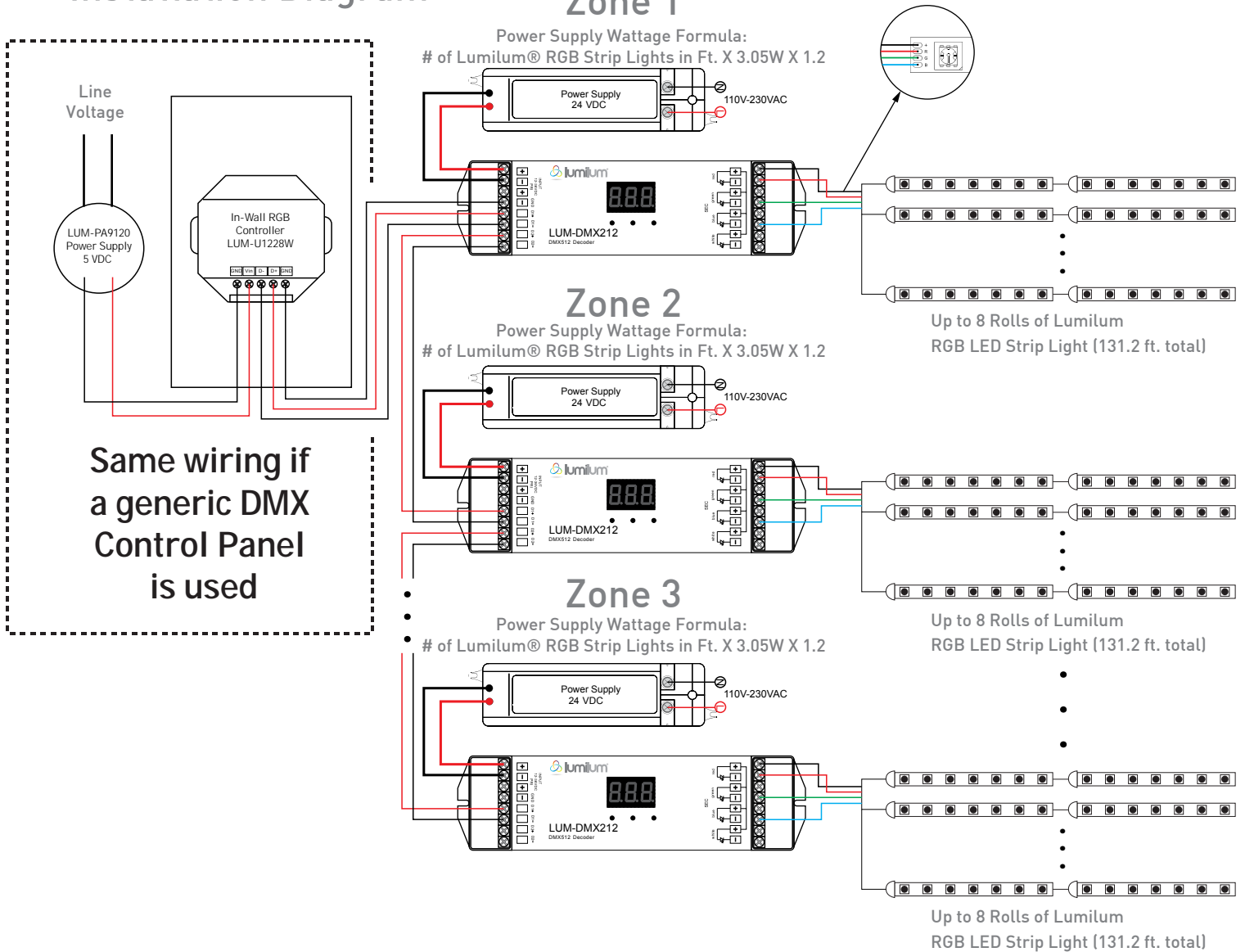

Multiple receivers may be used in each zone (set same DMX Address)

Wiring diagram is same when used with models:
LUM-DMX212 / LUM-DMXWP2