

PORTABLE PA AMPLIFIER SYSTEM

PROMIC PA-300W

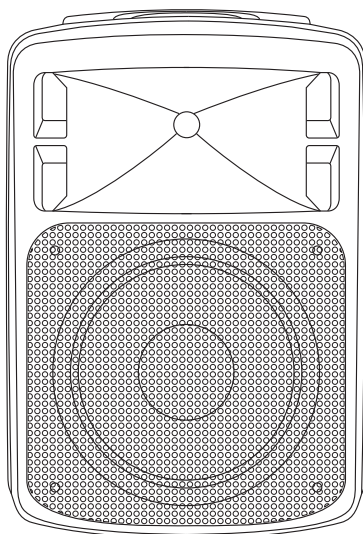

Table of Contents

1. Main Features and Quick Start Guide	1
2. Introduction and Product Specifications	2
3. Important Safety Information	3
4. Parts Description and Operation Guide	4~6
5. Wireless Microphone Operation Guide	7~10
6. Digital Audio Player With Bluetooth Operation Guide	11~14
7. Multi Format CD / DVD / USB / SD Media Player with Bluetooth	15~18
8. Rechargeable Battery Guidelines	19
9. Setting up Your Portable PA System	20
10. Useful Tips on Using Your PA System	20~21
11. Warranty Information	22~23

1. Main Features

The **Promic** range of Portable Public Address systems are the ultimate on-the-go take anywhere wireless solution.

- Fully self-contained all-in-one portable audio system.
- High performance class D amplification.
- 12 inch woofer and 1 inch tweeter drive.
- Sturdy injection moulded ABS impact resistant plastic body - extremely durable.
- Operate using mains power or built-in 25.2V 8Ah rechargeable battery.
- Up to 5 hours continual use on a full battery charge.
- Wireless handheld microphone transmitter included.
- Wireless microphone receiver with volume control included.
- Expansion slot for option of second wireless receiver for second wireless microphone.
- Wireless body pack transmitter with headset & lapel microphone available as option.
- Wired microphone 6.35mm / XLR inputs.
- Optional:
 - Multi-format Bluetooth media player with USB and SD card playback. Optional CD / DVD player available.
 - Remote control for media player.
 - Aux inputs for external music players such as smart phone etc.
 - Pull up handle, wheels and carry handle for easy transportation.
 - Audio line out to companion speakers.
 - Video out for connection to screen or projector (Optional DVD player only).
 - Voice priority function - fades music when microphone in operation (With on / off switch).
 - Tone (base and treble) and echo reverb controls.
 - 35mm tripod stand mount bracket in base (Tripod stand sold separately).

1.1. Quick Start Guide

- 1.1.1. Fully charge the unit for 7-10 hours before first use.
- 1.1.2. The wireless microphone(s) have been pre-configured to a suitable channel during testing. If you have a second wireless microphone receiver installed this is set to a different channel.
- 1.1.3. Insert the AA batteries into the handheld wireless microphone and turn on the microphone. Turn on the wireless receiver located on the top rear of the system by turning the volume switch to the right until it clicks on and the lights are illuminated. The red RF light will be on when the wireless microphone and wireless receiver are paired. Adjust the level of the microphone by the volume adjustment and the master volume control.
- 1.1.4. To play music or other audio insert a USB flash drive with stored MP3 files. Or connect any Aux device such as smartphone using the supplied audio cable.
- 1.1.5. To initialise Bluetooth mode short press MODE on Digital Media Player. On device open Bluetooth settings and connect to PA SYSTEM. When paired the LED on the Digital Media Player will display 'Bluetooth Connected'.

WARNING:

Do not connect any external device to USB slot other than USB flash memory drives.

This slot is not designed to charge or connect phones or any other USB device.

The voltage may damage the device.

2. Introduction and Product Specifications

2.1. Introduction





Thank you for choosing the PROMIC PA-300W Portable PA amplifier system. In order to get the best performance, please read this manual carefully before use. Please recharge this unit every month to achieve the best battery performance.

2.2. Product Specifications

	PROMIC PA-300W
Power Output	300W MAX 150W RMS
Amplifier	Class D
Frequency Response	50Hz-18KHz±3dB
Bass Driver	12" Woofer Speaker
Horn Tweeter	1" Tweeter
Distortion	1% (at 10W)
Audio Input - Wired Microphone	2 x Combined 6.35mm / XLR
Audio Input - Line In	1 x 3.5mm, 1 x 6.35mm, RCA (L) RCA (R)
Active Audio Output	6.35mm Active
Inactive Audio Output	RCA (L,R), 6.35mm
Video Output	RCA
AC Power Supply	100-240V switching power supply
Internal Battery	25.2V 8A Rechargeable Lithium Battery
Charge Time	Around 8-10 Hours
Standby Time	4-6 Hours (depending on volume setting)
Battery Indicator	Battery status. Low power
Battery Compartment	Rear accessible panel with 8 service screws
Colour	Black
Grille	1.5mm Steel with Powder Coat Finish
Tripod Mount	Moulded 35mm Tripod Mount on Base
Dimensions (L x W x H)	400 x 595 x 340mm
Weight	19.5kg
Operation Temperature Range	5 - 35C

3. Important Safety Information

In the event of a technical failure, please contact the your local dealer. Unauthorised repairs will void the warranty. One receiver cannot receive a signal from two or more same frequency microphones simultaneously. Other brands of wireless microphones with different frequencies cannot be used with this system.

<p>Do not open this product by yourself for adjustment. To reduce the risk of fire or electric shock, do not remove the cover. High voltage parts are inside.</p>	 Do Not Disassemble
<p>To reduce the risk of electric shock, do not touch power outlet during an electrical storm. Do not touch power plug with wet hands. Do not put vessel with liquid or small metal parts on the top of this equipment. Do not let metal or flammable parts drop into this equipment.</p>	 Do Not Touch
<p>To reduce the risk of fire or electric shock from damaged power cord, do not pull power cord strongly when pulling out the power plug. Always grasp the plug tightly then pull it out. Turn off the power if this equipment will not be used for a long period of time after setup.</p>	 Pull Out AC Plug
<p>To reduce the risk of electric shock, use the specified power voltage only. Do not expose equipment or power cord to strong sunlight or to moist or dusty conditions.</p>	 Forbidden
<p>To prevent damage from impact, do not place heavy objects on top of this equipment or place on uneven surfaces.</p>	
<p>Insert the power plug into power outlet entirely and clean regularly. Please pull out power plug and contact your dealer when the following happens:</p> <ol style="list-style-type: none"> ① When smoke comes out with burning smell from this equipment. ② Water or other liquid is accidentally spilt on this equipment. ③ Dropped on the ground and unit is damaged. ④ Power cord damaged (Cord core exposed or cord broken). ⑤ No sound output. 	 Forbidden

4. Parts Description

4.1. Main Unit

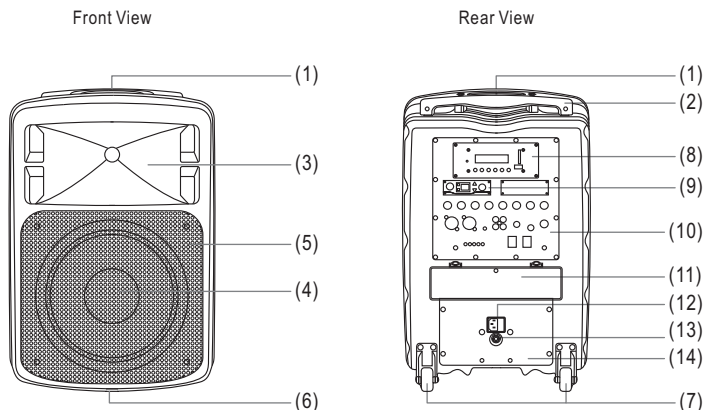

(1) Fixed Carry Handle

(2) Telescopic Trolley

(3) Tweeter Speaker

(4) Woofer Speaker

(5) Speaker Grill

(6) Speaker Stand Mount

(7) Wheels

(8) Multi Format CD / DVD MP3 Player
or Digital Audio Player

(9) UHF PLL Wireless Receiver Modules
(blanking plate fitted if no optional
second receiver installed)

(10) Control Board

(11) Power Supply

(12) AC Input

(13) Amplified Speaker Out

(14) Battery Compartment

(Pictures for reference only)

4.2.1. PA-300W Control Panel

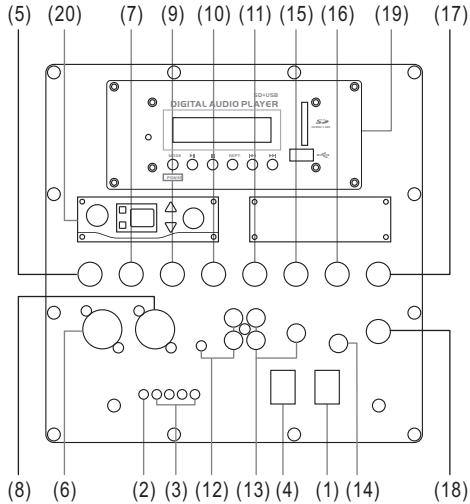

(1) Power Switch

(2) Power LED Indicator:

When voltage is low, red light appears.

(3) Battery Status LED Indicator:

Battery Supply: When battery voltage reduces from strong to weak, green indicator will extinguish one by one from right to left.

Battery Charge: When charging battery, power indicator will flash, with battery voltage enhancing from weak to strong, the indicator will light one by one, from left to right.

(4) Voice Priority Switch

(5) Volume Control MIC 1

(6) MIC 1 Input

(7) Volume Control MIC 2

(8) MIC 2 Input

(9) Tone Control

(10) Echo Control

(11) Volume Control for AUX

(12) Line In

(13) Line Out

(14) Video Out

(15) Media Player ON / OFF and Volume Control

(16) Bass Control

(17) Treble Control

(18) Master Volume Control

(19) MP3 Player

(20) Receiver Module

(Pictures for reference only)

4.2.2. PA-300W Control Panel Operation

Note: Before using this device, please use AC cord to charge internal battery.

Recharging time is 7-10 hours.

1. (A) When using AC power, switch power on (12) (**4.1. Main Unit**), power LED indicator (2) lights in green to indicate normal condition.
 - (B) When using built-in rechargeable battery, remove AC cord and switch power (1) on, power LED indicator (2) lights up in green to indicate normal condition. When Battery Status LED indicator (3) lights up in red, it indicates low battery power and a recharge is necessary.
 - (C) If battery voltage is very low the main unit will be powered off automatically.
 - (D) Insert the power cord into AC input jack (12) (**4.1. Main Unit**) and the device charges automatically.
2. Turn on handheld microphone or body pack transmitter (optional) power switch, RF LED indicator on wireless receiver will light. This indicates receiver has received microphone RF signal.
3. For wired microphone (optional) use, insert wired microphone cable into MIC 1 (6) or MIC 2 (8) jack, adjust volume control (5) or (7) accordingly.
4. If connecting system to external amplifier / speakers or second Promic PA System, connect audio cable into LINE OUT (13), then connect to external amplifier / active companion speakers. This output signal is combined from all inputs.
5. For more sound coverage connect a second non-powered / passive extension speaker into amplified speaker out.

Note: This feature is designed for 8 Ohm minimum impedance speakers. Overall amplifier output will be split between both speakers when in use.

6. To connect external audio devices such as portable music players / smart phones connect via Line Input (12) with suitable audio lead.
7. Instruments such as guitar should be connected to Line Input (12).
8. This unit has ECHO control (10) suitable for microphone use.
9. VOICE PRIORITY Function - fades music when microphone is in operation (4).
10. For recording insert audio lead to LINE OUT (13) and connect to suitable audio recording device.

Notes:

1. To use built-in rechargeable battery, please recharge the battery before operation. Switch off the power, plug in AC Cord to start to charge. Charging time is about 10 hours. Please recharge this unit every month.
2. If this system is not going to be used for a long time, charge the battery at least once a month. Pull out power plug and turn Power Switch to OFF position. See page (19) for more battery care guidelines.

5. Wireless Transmitter

5.1. Wireless Handheld Microphone Transmitter

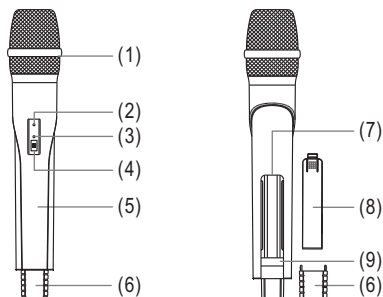

(1) Mesh & Capsule

(2) POWER LED Indicator

(3) Low Battery LED Indicator

(4) POWER Switch (ON / OFF)

(5) Microphone Body

(6) Replaceable Cap

(7) Battery Compartment

(8) Battery Cover

(9) IR SYNC Window

5.2. Wireless Handheld Microphone Operation

5.2.1. Open battery cover (8) and insert 2 x AA batteries paying attention to the polarity indicated with + or -.

5.2.2. Turn on microphone POWER switch (4), POWER LED indicator (2) will light up, low battery indicator (3) will flash once then off. When LOW battery indicator (3) lights up red, it indicates battery power is LOW. Please change battery for continued use.

5.2.3. When switching on microphone power, operate the switch step by step. When the switch moves to the centre, please stay for at least 0.5 second to avoid any noise through the system. Then move to ON position.

(Pictures for reference only)

5.3. Wireless Handheld Microphone Specifications

Microphone Type	Dynamic Handheld
Frequency Range	PLL 16 Channel Selectable UHF-5R (520.05 - 543.75 MHz)
Channel Set-up	IR Sync
Spurious Emissions	>55dBm
Transmitting Power	10mW
Power Source	2 x AA 1.5V Batteries (Included)
Operating Time	Approx >8 Hours
On-board Indicators	Power Status / Low Battery / On / Off Switch
Dimensions	Ø 50 mm, L 260mm
Weight	270g

6. Wireless Receiver Module

The PA-300W can have up to 2 x wireless microphone receivers installed into the expansion slots located centre right and centre left of the PA-300W control panel.

6.1. PLL Infrared Sync Receiver Module

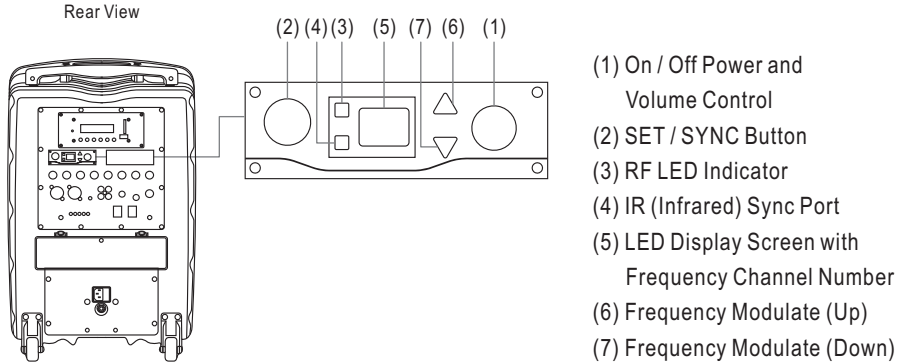

6.2. Wireless Receiver Module Operation

NOTE: The wireless microphone has been synced by default to a suitable channel during testing. If you have a second wireless microphone receiver installed this is set to a different channel. Please use the steps below if you wish to change the channel of the wireless receiver / microphone:

- 6.2.1. Long press (3 seconds) the SET / SYNC key on the receiver, switch to desired channel by UP / DOWN key when indicator bar is flashing.
- 6.2.2. Short press SET / SYNC key to confirm the desired channel. The indicator bar will stop flashing when the channel is selected.
- 6.2.3. With the handheld wireless microphone turned on, remove the battery cover. Face IR window to receiver IR window within 5-10cm.
- 6.2.4. Short press SET / SYNC again, the RF LED indicator will light up when the transmitter is paired on the selected channel on the receiver.
- 6.2.5. For the optional body pack transmitter follow steps 1 and 2 above and then simply match the displayed number on the receiver LED display and match with frequency dial on the body pack transmitter.
- 6.2.6. Only one wireless microphone can be connected to one wireless receiver. If a second wireless microphone is required then a second wireless receiver must be installed.

(Pictures for reference only)

6.3. Wireless Receiver Specifications

Receivers	Maximum Two Wireless Receivers (Horizontal)
Frequency Range	UHF-5R (520.05 - 543.75 MHz)
Preset Channels - UHF-5R	CH 1 - 520.05 MHz; CH 2 - 520.75 MHz; CH 3 - 521.85 MHz; CH 4 - 522.45 MHz; CH 5 - 523.35 MHz; CH 6 - 524.35 MHz; CH 7 - 525.15 MHz; CH 8 - 525.85 MHz; CH 9 - 527.95 MHz; CH 10 - 530.25 MHz; CH 11 - 531.95 MHz; CH 12 - 534.65 MHz; CH 13 - 536.55 MHz; CH 14 - 538.95 MHz; CH 15 - 541.45 MHz; CH 16 - 543.75 MHz
Oscillation Mode	PLL Synthesized
Receiving Mode	80Hz-15KHz (± 3 dB)
Frequency Response	-95dBm S/N ≥ 40 dB
Sensitivity	$\leq 1\%$
T.H.D	$\leq 1\%$
AF Output	450mV \pm 50mV
SNR	>80dB
Distortion	< 1%
Spurious Emissions	>80dB
Channel Set-up	IR Sync (Handheld Microphone) Manual (Optional Body Pack Transmitter)
Display	LED Channel Display, RF, IR
Working Distance	Up to 50m (Ideal)
Antenna	Built-in / Internal
Current Consumption	130mV \pm 20mV

7. Digital Audio Player With Bluetooth

7.1 Parts Description

A. Front Panel

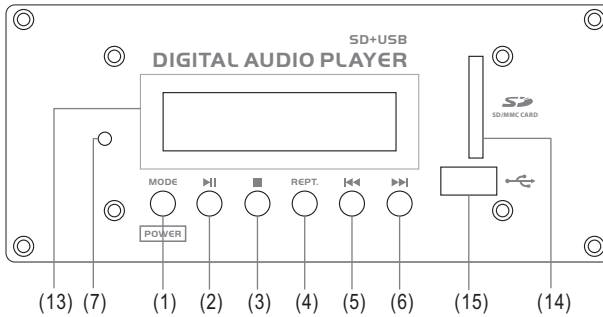

B. Remote Control

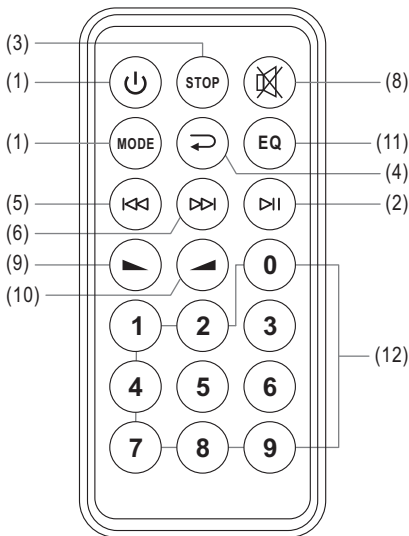

- (1) Mode / Power Key
- (2) Play / Pause
- (3) Stop
- (4) Repeat
- (5) Skip Previous / Rewind
- (6) Skip Next / Fast Forward
- (7) IR Signal Receiving Port
- (8) Mute
- (9) VOL-
- (10) VOL +
- (11) EQ
- (12) Number Keys
- (13) LCD Display
- (14) SD Card Slot
- (15) USB Port

(Pictures for reference only)

C. Digital Audio Player Specifications / Functions

Bluetooth	Bluetooth 2.0 Pairing with Appropriate Device
USB	Supports MP3 / WMA USB 2.0 High Speed Playback from Solid State USB Drive up to 16GB
SD	Supports MP3 / WMA Playback from Solid State SD Card up to 8GB
On-Board Functions	Mode / Power On / Off, Play / Pause, Stop, Repeat, Skip Previous / Rewind, Skip Next / Fast Forward
Remote Functions	Power On / Off, Stop, Mute, Mode, Return, EQ, Skip Previous / Rewind, Skip Next / Fast Forward, Play / Pause, Vol -, Volume +, Numeric Key
Display	LCD Display Including Artist, Song Name, Modes etc
EQ Modes	Jazz, Rock, Pop, Classic

WARNING:

Do not connect any external device to USB slot other than USB Flash Memory drives. This slot is not designed to charge or connect phones or any other USB devices. The voltage may damage the device.

7.2. Operation Guide

Basic Operation

- 7.2.1. Switch on the MP3 / Power switch on the PA System main control panel and set to appropriate volume level. Long pressing "MODE" (1) on the player or Power Key (1) also turns the multi format MP3 player on and off.
- 7.2.2. Insert SD card into slot (16), or insert USB flash drive into slot (17). Files will be read automatically; If both SD card and USB are inserted simultaneously, press "SD / USB" (15) to shift between the drives.

Connecting Bluetooth Device

- 7.2.3. Short press 'MODE' on media player or remote control to initialise Bluetooth mode. Open Bluetooth settings on Bluetooth device (such as a Smartphone, tablet, iPod etc) and connect to 'PA SYSTEM'.
- 7.2.4. When paired the LED on the PA System will display 'Bluetooth Connected'.
- 7.2.5. The Bluetooth device and PA SYSTEM are now connected for streaming music wirelessly from device.

Playback Operation

- 7.2.6. On front panel or remote control, press "PLAY / PAUSE" (2) once to pause while track is playing, press again to resume play.
- 7.2.7. On front panel or remote control, Short press "Skip Previous / Rewind" (5): Skip Previous; Long press: Rewind.
- 7.2.8. On front panel or remote control, Short press "Skip Next / Fast Forward" (6): Skip Next; Long press: Fast Forward.
- 7.2.9. MUTE mode: On remote control, Short press "MUTE" (8) for mute mode.
- 7.2.10. REPEAT mode: Press "REPEAT" (10) enter into repeat play setting:

Repeat All	Random Play	Repeat One
------------	-------------	------------

- a. Repeat all: repeat all the songs in the selected memory
- b. Random: play all the songs in random order
- c. Repeat one: repeat only the current selected song

7.2.11. Equalizer: Short press "EQ" (8) to adjust equalizer, the following equalizer preset are available: Natural, Jazz, Rock, Pop, Classical.

Natural	Jazz	Rock	Pop	Classic
---------	------	------	-----	---------

General Warnings:

- a. Before using a new (unformatted) USB Flash Drive or SD Flash Card with the digital audio player please format the card (FAT32).
- b. If the player freezes up for any reason, turn it off for 3 seconds, and then turn the power back on.
- c. Do not connect any external device to USB slot other than USB flash memory drives. This slot is not designed to charge or connect phones or any other devices.

8. Multi Format CD / DVD / USB / SD Media Player with Bluetooth

8.1. Parts Description

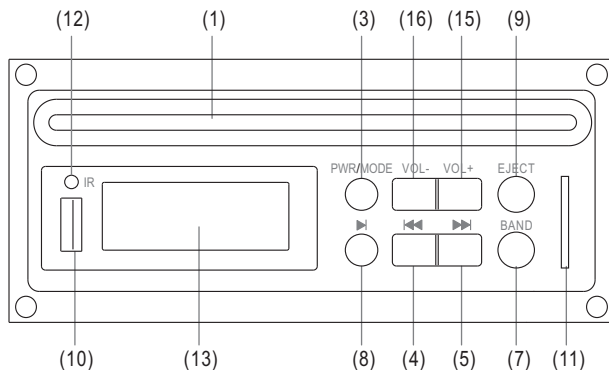

Remote Control

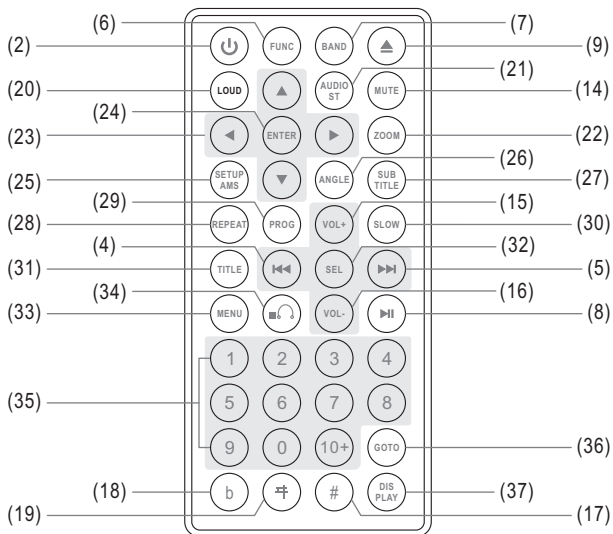

(Pictures for reference only)

8.2. Parts Description

- | | |
|---|---|
| (1) DISC Slot | (18) Pitch Down |
| (2) Power Switch | (19) Default |
| (3) Power / Mode Button | (20) Loud |
| (4) Short Press: Skip Previous / Chapter;
Long Press: Rewind;
On the Radio by Scanning. | (21) Audio / ST |
| (5) Short Press: Skip Next / Chapter;
Long Press: Fast Forward;
On the Radio by Scanning. | (22) Zoom |
| (6) Function Mode | (23) Arrow Buttons |
| (7) Band Mode | (24) Menu Enter |
| (8) Play / Pause | (25) Setup / AMS |
| (9) Eject | (26) Key for Angle |
| (10) USB Port | (27) Sub / Title / Language Setting |
| (11) SD Card Slot | (28) Repeat |
| (12) Infrared Sensor | (29) PROG |
| (13) LCD Display | (30) Slow |
| (14) Mute | (31) Key for Title of DISC |
| (15) VOL+ | (32) Key for DSP-Off, Loud on,
Volume / Function Selection |
| (16) VOL- | (33) Menu |
| (17) Pitch Up | (34) Stop / Back |
| | (35) Number Keys |
| | (36) GOTO Playing Time Setting |
| | (37) Display Time |

WARNING:

Do not connect any external device to USB slot other than USB flash memory drives. This slot is not designed to charge or connect phones or any other USB device. The voltage may damage the device.

8.3. Operation Guide

- 8.3.1. Press Power switch (2) / (3) to turn on the multi format player, press again to switch off.
- 8.3.2. To connect via Bluetooth, short press key "MODE" (3) on control panel to initialize BLUETOOTH mode. The LCD display will read "NO LINK". Open Bluetooth function on device and search. Device will find "PA SYSTEM" after the search. The LCD will display "LINK OK" when it is paired. Audio from the Bluetooth device will then be transferred to PA SYSTEM.
- 8.3.3. The built-in DVD player uses the high quality DVD movement, can play the whole region in multiple formats of DVD / DVD-9 / VCD / DVCD / MP3 / CD-R / RW and other formats.
- 8.3.4. While the multi format player is working, if there is no disc in (1), then the LCD display (13) will display "NO DISC", if the disc has not been placed correctly, the LCD display (13) will also display "NO DISC"; If the disc has been placed correctly, the LCD display (13) will display TITLE and Playing Time.
- 8.3.5. While the file is playing:
 - a. Press key PLAY / PAUSE (8) on the multi media player or key PLAY / PAUSE (8) on the remote control, the file will be stopped, it will display PAUSE on the LCD display, press again to resume PLAY.
 - b. Press key STOP (3) on the multi format player or key STOP (34) on the remote control, the file will be stopped and the LCD display (13) will be displayed STOP on the LCD display.
 - (a). While the file has been stopped, press key PLAY / PAUSE (8) on the multi format player or key PLAY / PAUSE (8) on the remote control, the current file can be played again.
 - (b). While the file has been stopped, repeat press key STOP / BACK (34) on the remote control, then press key PLAY / PAUSE (8) on multi format player or the Key PLAY / PAUSE (8) on the remote control, the first file will be played.
- 8.3.6. Press key EJECT (9) on the multi format player or key EJECT (9) on the remote control, the disc will be ejected automatically, and it will take about 30 seconds to slot the disc in automatically again.
- 8.3.7. Selection / music / fast forward / backward : press this button (4) / (5) in the radio can be upper / lower search radio. In SD / USB can be read, upper / lower selections, long press fast forward / rewind.
- 8.3.8. Press key BAND (7) on the multi format player is with. On the radio for the band. Press key FUNC (6) on the remote control, you can select function radio / palyback of / USB / SD.
- 8.3.9. While the DISC is playing. Press key BAND (7) on the remote control to select NTSC, PAL, AUTO.

- 8.3.10. While video output or audio output, press key VOL+ (15) / VOL- (16) on remote control to adjust the volume. Press key VOL+ (15) to increase volume, press key VOL- (16) to decrease volume; Press key # (17) / key b (18) on remote control to adjust pitch control, Press key # (17) to adjust pitch up, press key b (18) to adjust pitch down; Press key MUTE (14) on the remote control to mute the audio, the LCD display will display MUTE, press again to resume audio; Press key ♯ (19) to resume original audio.
- 8.3.11. While playing CD, press LOUD (20) on the remote control to increase the bass effect.
- 8.3.12. While playing CD, press (21) on the remote control to select left channel, right channel and stereo. Please be noted to select voice mode you should pay attention to various kinds of discs, some of the disc that only have one voice mode, when the key voice mode has been selected, it will be displayed on the LCD display.
- 8.3.13. Under the mode of playing DVD / VCD, Press button (22) on the remote control to zoom in or zoom out the image, Press (30) to play slowly. Press (31) to return to sub catalog.
- 8.3.14. Press MENU on the remote control to set up main menu (33), then the PBC can be played, all the menu will be displayed on the LCD disc player, and then press Numeric Key (35) to select the song, while playing any of the songs on the PBC, press again to cancel the PBC playing. While playing DVD, press (33) once to set up the main menu, or return to main menu, all the menu will be displayed on the LCD disc player, and then press Numeric Key (35) to select the chapter, press again to enter into title menu, press thrice to switch off; Press (26) on the remote control to select the angle of viewing the image.
- 8.3.15. The language of the DVD can be set up according to the disc. Press (27) on the remote control to change the language. Subtitles can only be selected in DVD mode.
- 8.3.16. To set the sequence of pre-recorded files, press (29) on the remote control. P00:00 will be displayed. Press the Numeric Key (35) to select playing sequence of the files to be programmed. Press (23) to play.
- 8.3.17. Press (25) on the remote control to enter in to main menu, then press (23) to setup the standard of TV system, audio, media, Television system and code etc (You can choose the current setting with the multi media player without changing).
- 8.3.18. Press (28) to repeat the single file or all the files.
- 8.3.19. Repeat pressing (32) on the remote control to select the acoustic characteristic.
- 8.3.20. Press (37) to know the total lead time and time left for the files.

9.1. Rechargeable Lithium-ion Battery

The Promic PA-300W Portable PA System has a 25.2V 8A lithium-ion rechargeable battery built in. In order to maximise the lifespan and performance of the rechargeable battery please follow these simple guidelines:

- 9.1.1. Before use it is advisable to charge the battery for around 10 hours until they are fully charged.
- 9.1.2. After each use charge the battery fully before storing the system.
- 9.1.3. It is advised not to leave the system on charge for a period exceeding 24 hours.
- 9.1.4. To maintain performance and lifespan of the battery fully charge the battery every 10-12 weeks –even if the system has not been used.
- 9.1.5. If the battery is fully discharged, please recharge fully within 72 hours or the battery may be permanently damaged.
- 9.1.6. The internal rechargeable battery is warranted for three months from original purchase date. Damage to battery after this time will not be covered by warranty. Replacement battery are available.
- 9.1.7. The average lifespan of battery is around 300-500 cycles or 1-2 years under normal use. The user is advised that a change of battery may be required during this time.
- 9.1.8. Performance and efficiency of battery are affected by changes in the environment, especially temperature and humidity. The system should be kept between 5°C-45°C. For optimum result, 15°C-35°C is ideal.

9.2. Replacing the battery in the PA-300W

- 9.2.1. Remove screws on the battery door which locate at the rear side of the unit.
- 9.2.2. Remove plastic battery cover.
- 9.2.3. Slide out battery from battery compartment and remove cables from battery terminals.
- 9.2.4. Replace the battery with the new battery taking care to match the positive and negative lead to the battery.
- 9.2.5. Re-install battery fixing plate and plastic battery cover then fully charge the battery as normal.

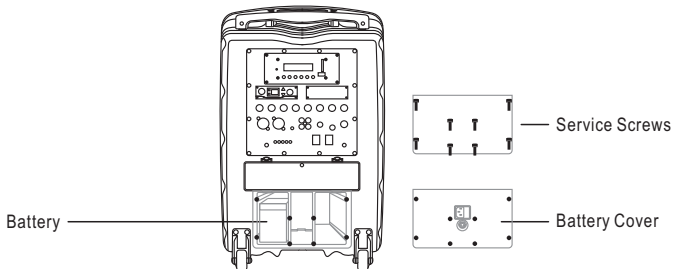

10. Handy Tips on Setting up Your Promic PA-300W Portable PA System

The Promic PA-300W Portable PA System has been designed for a all-in-one portable solution that is easy to set up and get working. In order to get the most out of your Portable PA System please follow these simple guidelines:

- 10.1. Charge your portable system the day before use.
- 10.2. Make sure that you have a stand for the PA speaker. It is extremely important to elevate and place the speaker at an appropriate position to maximise its coverage and minimise feedback.
- 10.3. To avoid feedback, do not place the microphone directly in front of the portable loudspeaker.
- 10.4. Position the speaker in front of the microphone user so it is further towards the audience.
- 10.5. Do not position the PA speaker too far from the person speaking.
- 10.6. Work on your microphone technique. A vocal microphone needs to be held right up to the mouth.
The further away the microphone is positioned from the mouth the lower the audio output.
- 10.7. Test the microphone levels before your event. Stand at the farthest end of the venue and listen carefully to get a feel of what is being said during the sound check.
- 10.8. Always have spare AA batteries for the wireless microphone and always have a corded microphone on hand. Often wireless microphones are left on accidentally and may have no battery charge so having a corded microphone always means a microphone is available.
- 10.9. Do not forget to recharge the PA system after each use.

11. Accessories Available for Your Promic PA-300W System

11.1. Dynamic Wired Microphone

This is a necessity in case your wireless microphone has been left on accidentally and has no charge. It's also great to be able to have 2 people talk / perform at the same time.

11.2. Portable Tripod Speaker Stand

Extremely beneficial to give optimal elevated placement of the PA System to increase the spread of sound as it's at ear level. It also helps by allowing easy access to all the controls and keeping the unit off wet grass! Supplied with bonus carry bag.

11.3. Additional 16 Channel Wireless Receiver Module

This PA System has one wireless microphone receiver already installed for connecting to either the wireless handheld microphone or wireless body pack transmitter. Another module can be installed for concurrent use with 2 wireless microphones.

11.4. Additional 16 Channel Wireless Handheld Microphone Transmitter

For use with the additional receiver module (above) or keep as a spare for the included receiver module.

11.5. Wireless body Pack Transmitter, Headset & Lapel Microphone

Hands free speech or performing / presenting. Includes basic lapel and headset microphones.

11.6. Boom Microphone Stand

Useful microphone stand for hands free operation of wireless or wired microphones.

11.7. Folding Headset Microphone

Small, lightweight discreet headset microphone for use with wireless body pack transmitter.

11.8. Aerobic Headset Microphone

Water resistant lightweight aerobic headset microphone for use with wireless body pack transmitter.

11.9. Extension Speaker

Professional slave extension speaker. Suitable for outdoor events where maximum coverage is required without power.

12. PROMIC PA-300W Warranty

“Seller” warrants the “Product” and accessories contained in the original packaging (“Product”) against defects in materials and workmanship when used normally in accordance with published guidelines for a period of 2 Years from the date of original consignment by the end-user purchaser (“Warranty Period”). Published guidelines include but are not limited to information contained in technical specifications, user manuals and service communications. Seller warrants that the goods, whilst they remain in the possession of the Buyer, will under proper use, be free from defects solely due to faulty workmanship and materials during a period of 2 Years from consignment, to the extent that upon authorised return to Seller freight prepaid during that period of any part of the goods covered by this warranty, Seller will if it finds such part to be so defective, at its option repair such part or supply a replacement part provided that the goods or any part are not without Seller's consent altered, repaired or subjected to any technical attention by any person other than Seller's authorised representatives.

This Warranty does not apply :

- (a) To consumable parts, such as battery or protective coatings that are designed to diminish over time, unless failure has occurred due to a defect in materials or workmanship;
- (b) To cosmetic damage, including but not limited to scratches, dents, engravings and broken plastic on microphones or other plastic parts;
- (c) To damage caused by use with another product;
- (d) To damage caused by accident, abuse, misuse, liquid contact, fire, earthquake or other external cause;
- (f) To damage caused by service (including upgrades and expansions) performed by anyone who is not an Authorised Service Provider;
- (g) If an incorrect voltage power supply is used with this product.

Except as herein provided, all conditions and warranties in respect of the goods, expressed or implied statutory or otherwise are hereby excluded. Under no circumstances shall Seller be liable to pay compensation for any injury, loss or damage sustained by Buyer howsoever arising.

Our goods come with guarantees that cannot be excluded under the Australian Consumer Law. You are entitled to a replacement or refund for a major failure and compensation for any other reasonably foreseeable loss or damage. You are also entitled to have the goods repaired or replaced if the goods fail to be of acceptable quality and the failure does not amount to a major failure.

13. How to Make a Warranty Claim

1. Email your claim to Seller at service@talkaudiovisual.com.au with the following information :
 - (i) Organisation or customer name
 - (ii) Approximate date of purchase
 - (iii) Product model number (PA-300W)
 - (iv) Full details of fault (e.g. Wireless Microphone malfunction). Please provide as much information as possible including photographs if necessary.
2. A warranty case number will be provided as soon as possible and instructions on the appropriate action will be given.
3. If warranty service is required, the product is to be returned in its original packaging (or substantial alternative) by prepaid freight. Please use warranty case number as a reference.
4. Seller is not responsible for Product whilst in transit for loss or damage. Insured delivery by courier with proof of delivery is recommended.
5. Return freight will be paid by Seller after repair or replacement within reasonable timeframe.

Designed and Manufactured For:
TALKAUDIO VISUAL AUSTRALIA
www.talkaudiovisual.com.au
1300 55 22 90
info@talkaudiovisual.com.au

