

BAY ST



SCAN AND
WATCH ON
YOUR PHONE

ORU KAYAK



Assembly Guide (Pages 1-13)
Disassembly Guide (Pages 14-18)

Read this entire Assembly
Guide before assembling
your Oru Kayak.

◀ **IMPORTANT** ▶

Watch the instruction video:
www.orukayak.com/assembly/bayst

SERVICE@ORUKAYAK.COM

Step 1: Open the Oru Kayak box

The box contains all the components needed for assembly and includes space to store gear—such as our 4-piece paddle.

- A** Loosen and slide off the two loops that go around box. Set shoulder strap aside (you won't need it while kayaking).
- B** Unclip and lift the lid off. This will become the kayak's floorboard.
- C** Remove the loose kayak components packed into the box. See page 2 for a list of the loose components. Additional components are permanently attached to the hull/deck.

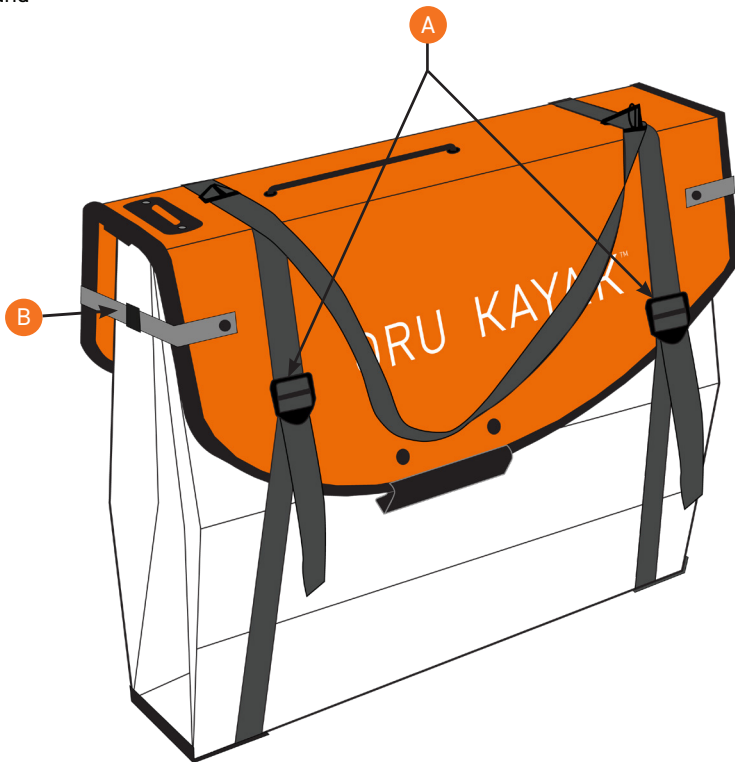

Getting Familiar assembly components

- 1 Shoulder strap:** Used to carry the kayak when in box form. Stow out of the way while kayaking.

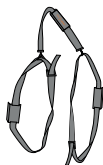

- 2 Floorboard:** Reinforces the kayak bottom and holds the seat.

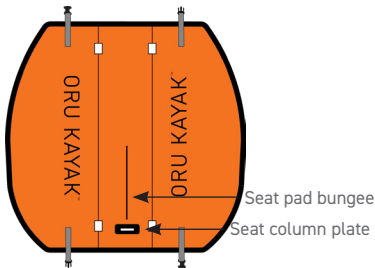

- 3 Zipper Channels:** Close the deck of the kayak



- 4 Bow (front) Bulkhead/Footrest:** Attached to the front half of the kayak. Provides structural rigidity and comfort.

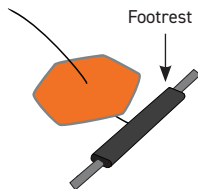

- 5 Stern (back) bulkhead:** Provides structural rigidity.

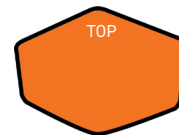

- 6 Bulkhead channels:** Attached to the inner hull. Used to hold the two bulkheads in securely.



- 7 Backrest:** Includes the seat column and adjustable backrest.



- 8 Seat pad:** Tucks under the bungee in the floorboard.

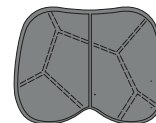

- 9 Spare parts kit:** Extra hardware for repairs and upkeep.

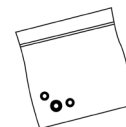

Step 2: Unfold the box

- A** Unclip the gray strap in the middle that is keeping the kayak closed.
- B** Hold the two folds at the orange stickers. Pull as indicated in the illustration (left) to open. The skin will be stiff.
- C** Push the ends apart to extend the box into a long sheet.
- D** Pop the hull flat with your hands as you extend it, pushing down the inverted folds, creating a bowl shape.

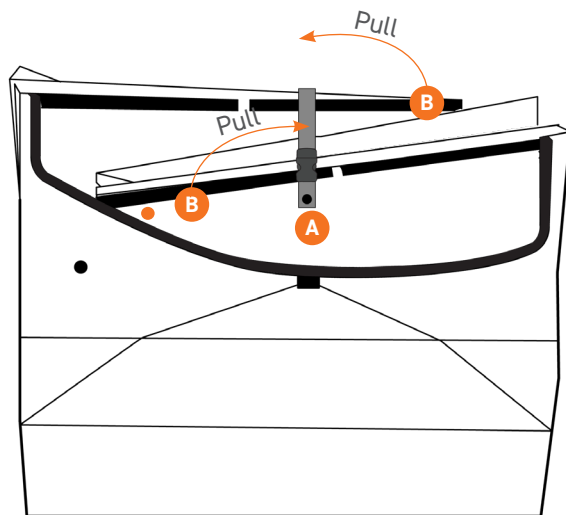

NOTE

The double-walled corrugated polypropylene that Oru Kayaks are made from will naturally show marks and scratches from use over time. As long as the hull is not punctured, there is nothing to worry about. Think of them like marks and scratches on thick leather boots.

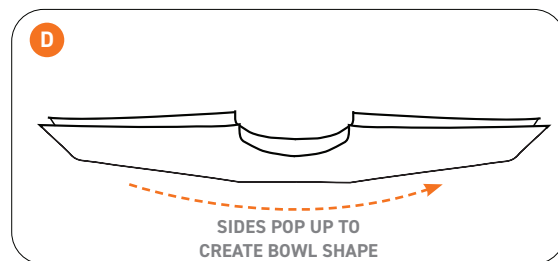
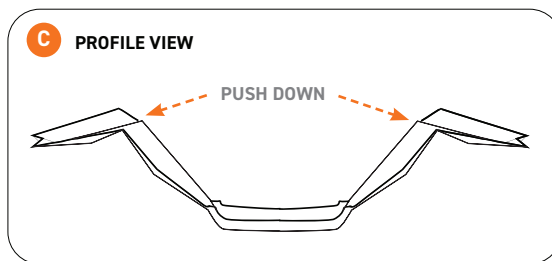

Parts: Hull/deck

The box becomes the hull and deck of the kayak. Several key parts are permanently attached to the hull/deck. The bow (front) and stern (back) of the Oru Kayak are different, so pay attention to orientation throughout the assembly process.

- 1 Fairings:** These finish the boat at the bow and stern, and include handles for carrying the kayak.
- 2 Tension strap:** Provides additional rigidity to the hull of the kayak.
- 3 Bow and stern bulkheads:** Provide structural rigidity. **Note - The bow bulkhead will need to be unhooked from the gray strap before use.**

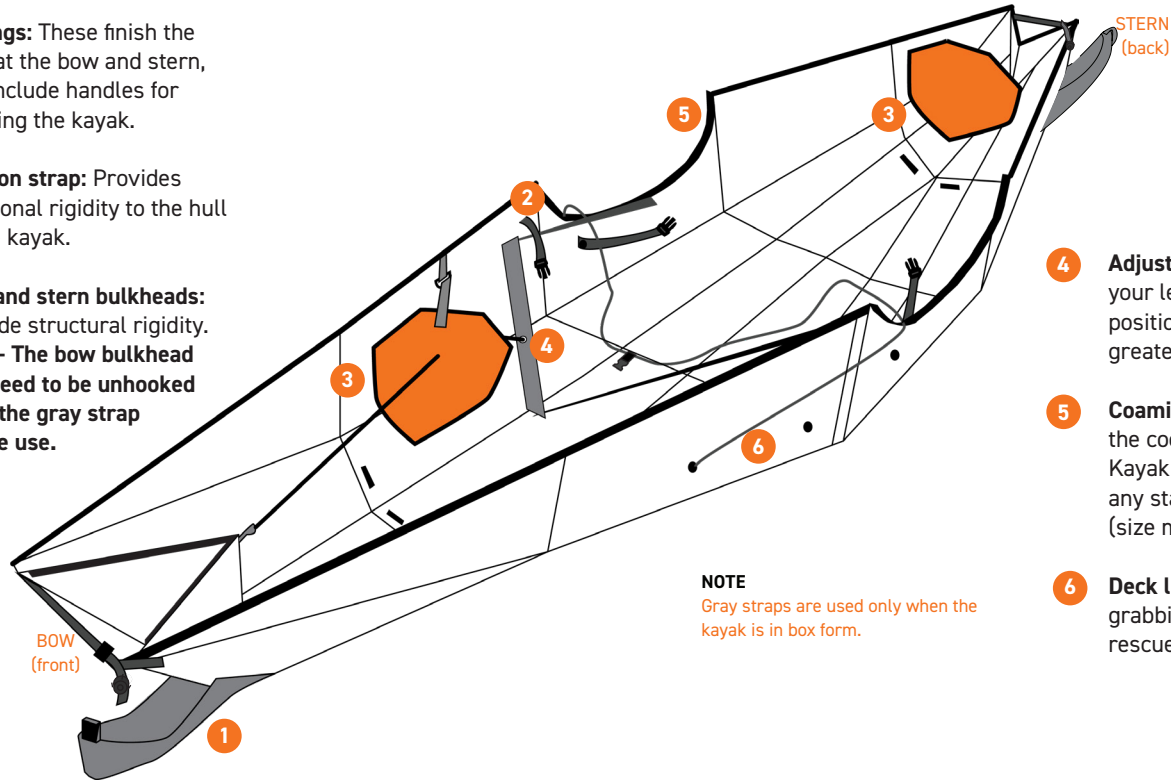

- 4 Adjustable footrest:** Keeps your legs in a comfortable position and gives you greater control of the kayak.
- 5 Coaming:** The rim around the cockpit can hold the Oru Kayak spray skirt as well as any standard spray skirt (size medium), if desired.
- 6 Deck lines:** Provide a secure grabbing point during a rescue.

NOTE

Gray straps are used only when the kayak is in box form.

Parts: Floorboard

The box lid becomes the floorboard. The floorboard is a crucial part of the Oru Kayak assembly; it locks into the cockpit at the coaming, adding structure, and holds the seat pad and backrest.

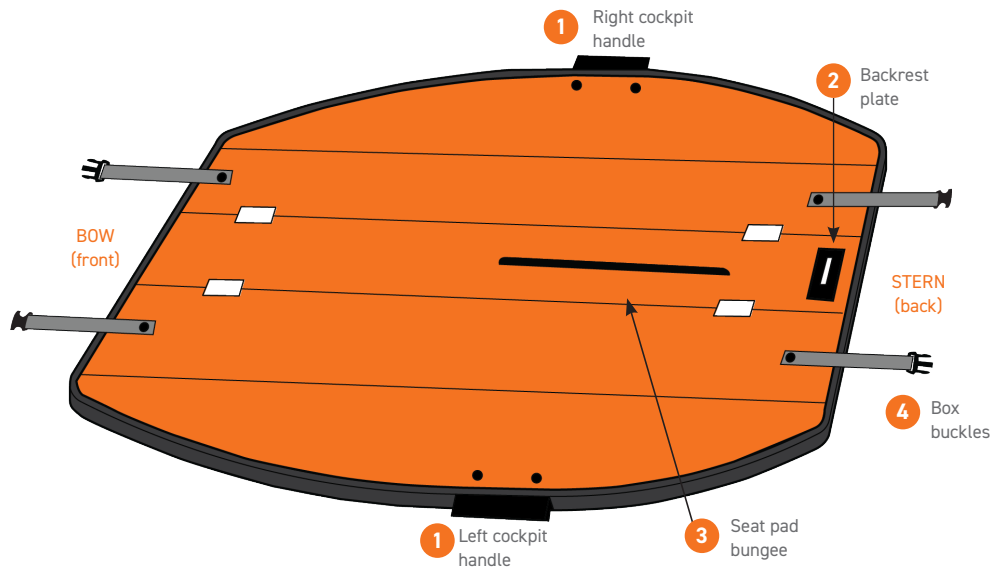

- 1 Cockpit handles:** Lock into the coaming and provide support when entering or exiting the kayak.
- 2 Backrest plate:** Holds the backrest and column (see Step 7).
- 3 Seat pad bungee:** The seat pad tucks under the bungee in the center of the floorboard.
- 4 Box buckles:** Two sets of buckles hold the box closed, but are not used when in kayak form.

Step 3: Insert the floorboard

The floorboard adds structure to the cockpit area. The floorboard handles lock into the coaming (this is around the rim of the cockpit) to hold the floorboard in place.

- A** Make sure that the floorboard backrest plate is on the stern side of the kayak.

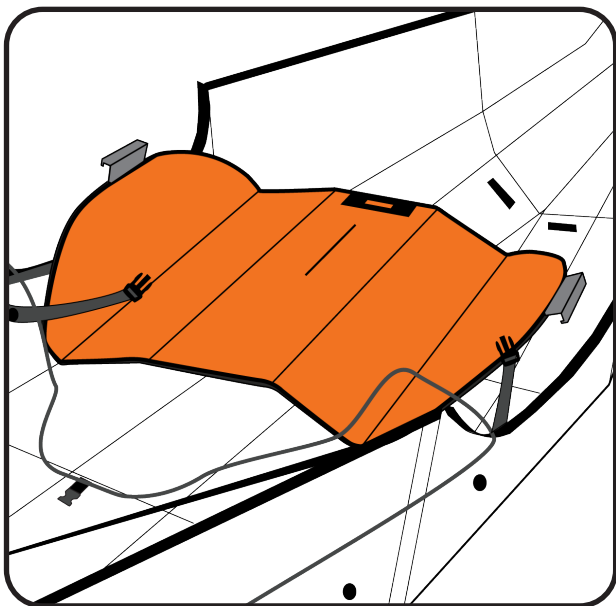

- B** Prop the kayak on its side, and align the floorboard handle with the ridge in the coaming. Rotate inwards, until you hear a “snap.” See note. Flip kayak and repeat on the other side.

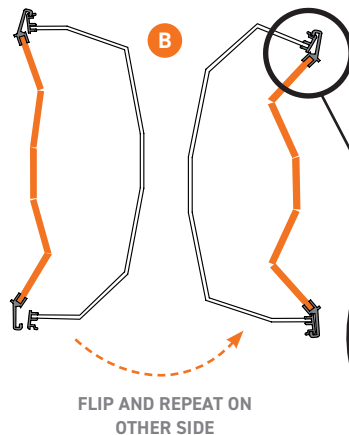

- C** After locking in both sides and pushing down in the center of the floorboard, you'll find that the kayak retains its “boat shape.”

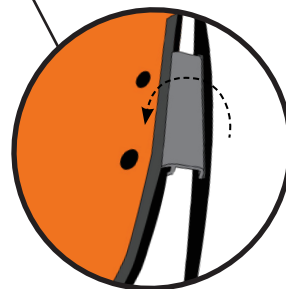
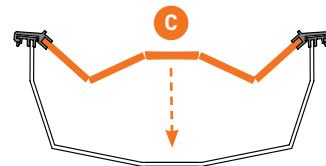

NOTE

Handle goes into groove on the coaming. Rotate the cockpit handle to lock into the coaming, as shown, until you hear a “click” sound.

Step 4: Tighten end straps/Insert bulkheads

The end straps help seal the bow and stern while the bulkheads provide rigidity to the hull.

- A** Make sure the ends of the bow and stern are inverted. Tighten the bow and stern using the end straps (see note). This will begin to shape the kayak and make it easier to install the zipper. Make sure the foam plug stays on the outside.
- B** Unhook the bow bulkhead from the gray ring strap and insert into the bulkhead channel. Make sure to line up the graphic on the bulkhead with the channel.
- C** Insert the stern bulkhead.
- D** Make sure the decklines are in the cockpit so they are out of the way during the next steps.

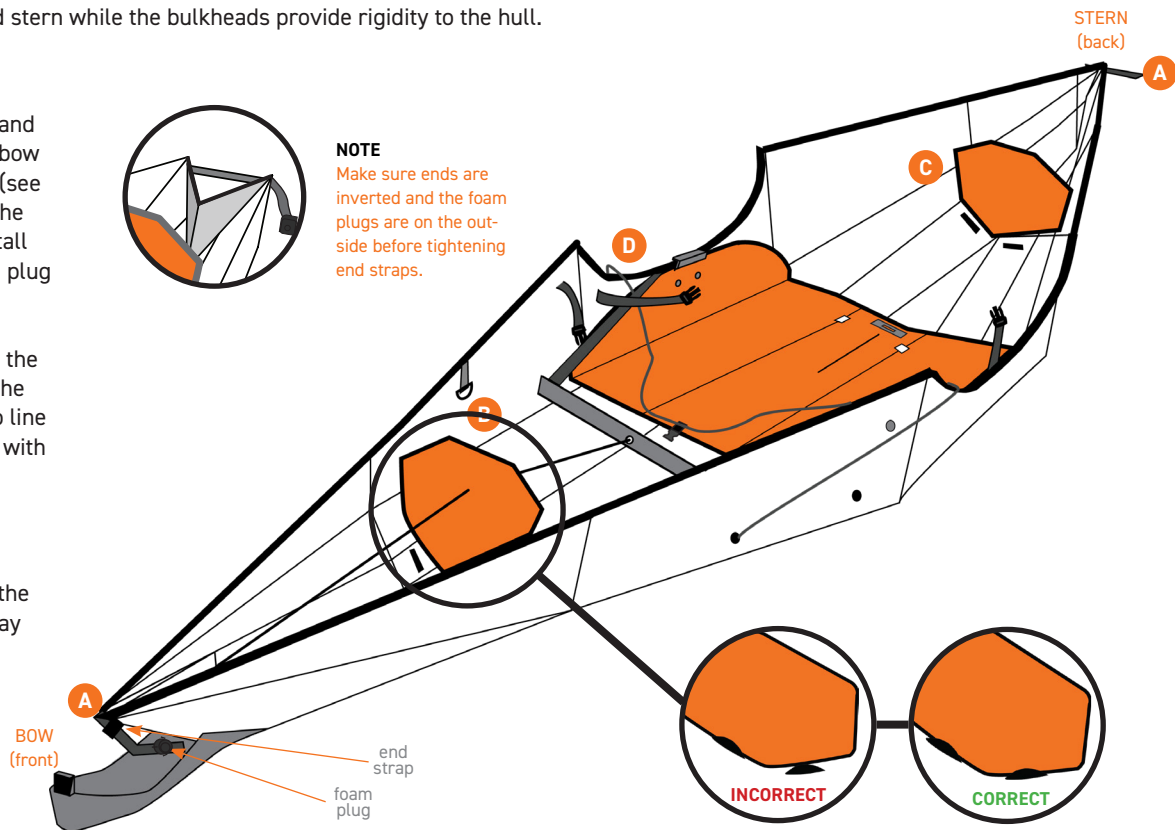

Step 5: Buckle tension strap

Use the tension strap to help close the kayak.

- A** The tension strap is located inside the hull underneath the bow coaming latch.
- B** Connect the buckle and tighten until the two halves of the coaming are touching.

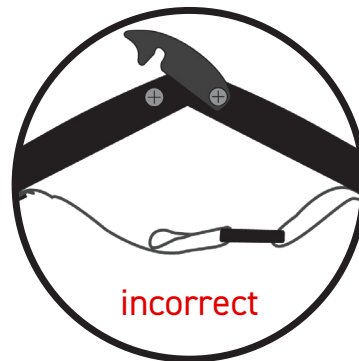
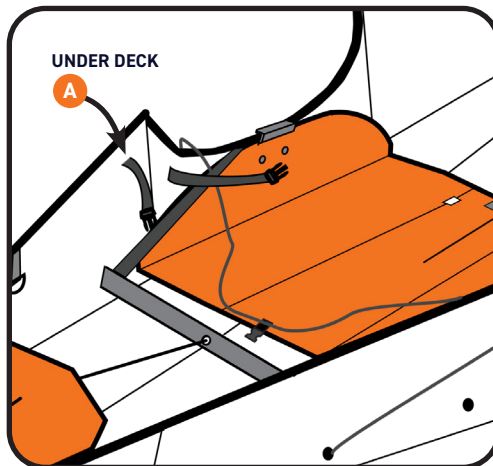
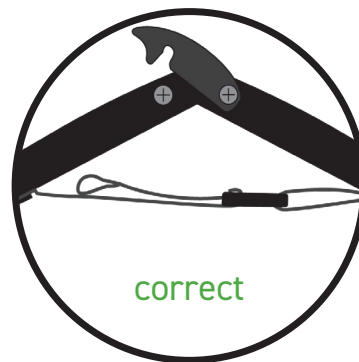
**B**

Step 6: Slide on front zipper channels

The zipper channels seal the deck of the kayak.

- A** Holding the bow of the kayak, begin to guide the zipper channel onto the deck trim (see tip). Do not force the zipper on as it may cause damage to the kayak. **Make sure that the bulkhead stays inside of the bulkhead channels.**

- B** Continue both zippers are on the bow of the kayak. Check to make sure each zipper channel is properly installed.

- C** Close the bow coaming latch.

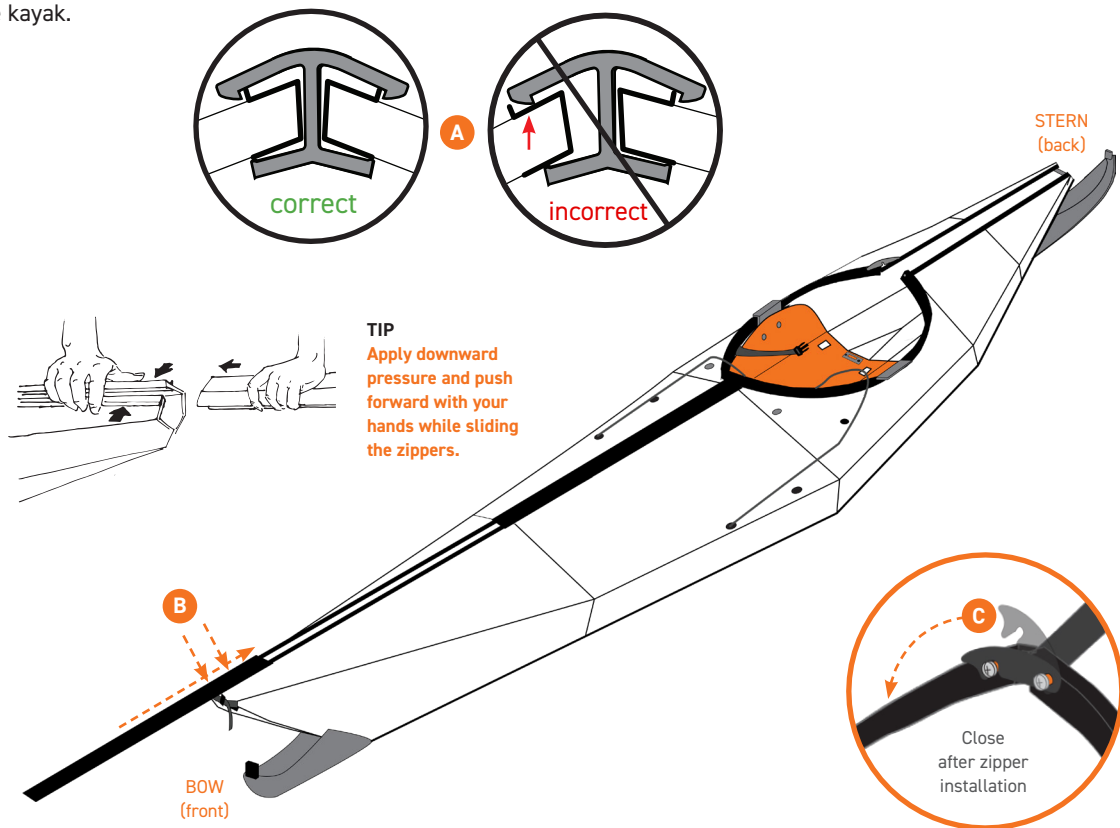

Step 7: Attach rear seat column

Closing the back of the kayak is similar to closing the front (step 6). You'll also install the backrest column, which supports the rear cockpit area.

A Insert the backrest column into the slotted backrest plate in the floorboard. Tilt upward to lock the backrest column in place.

B Lock the top of the backrest column into the two shiny screws on the coaming of the kayak (see close up).

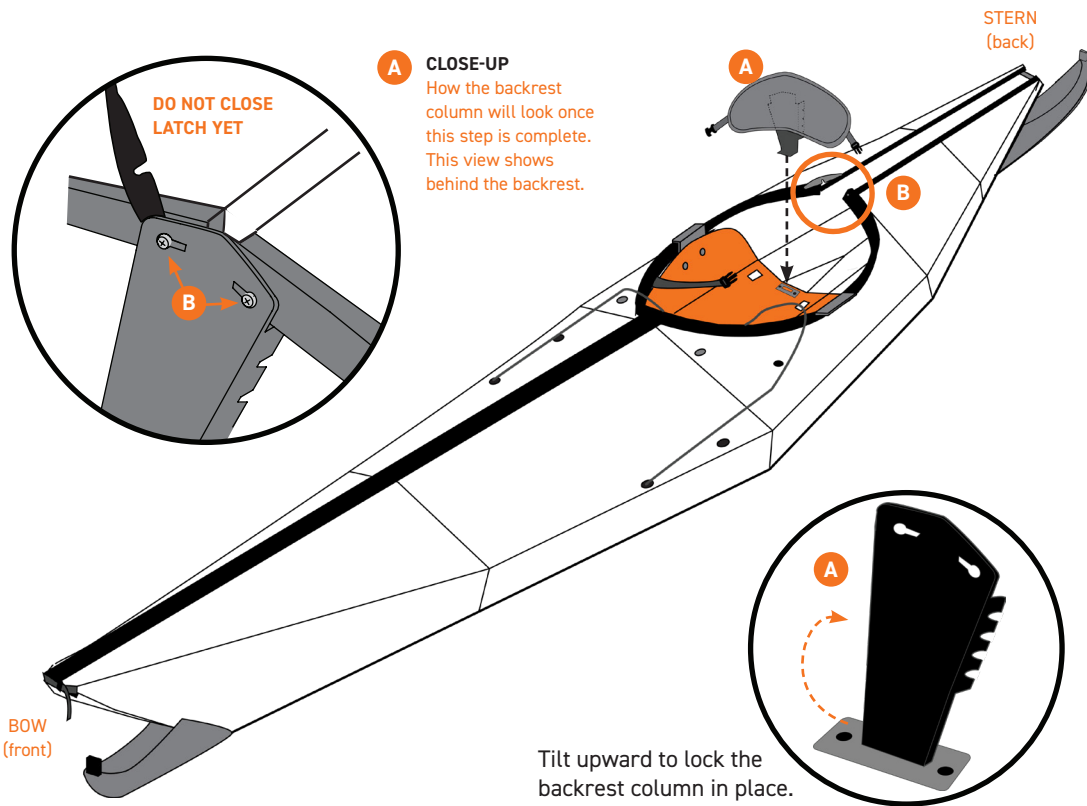

Step 8: Slide on rear zipper channels

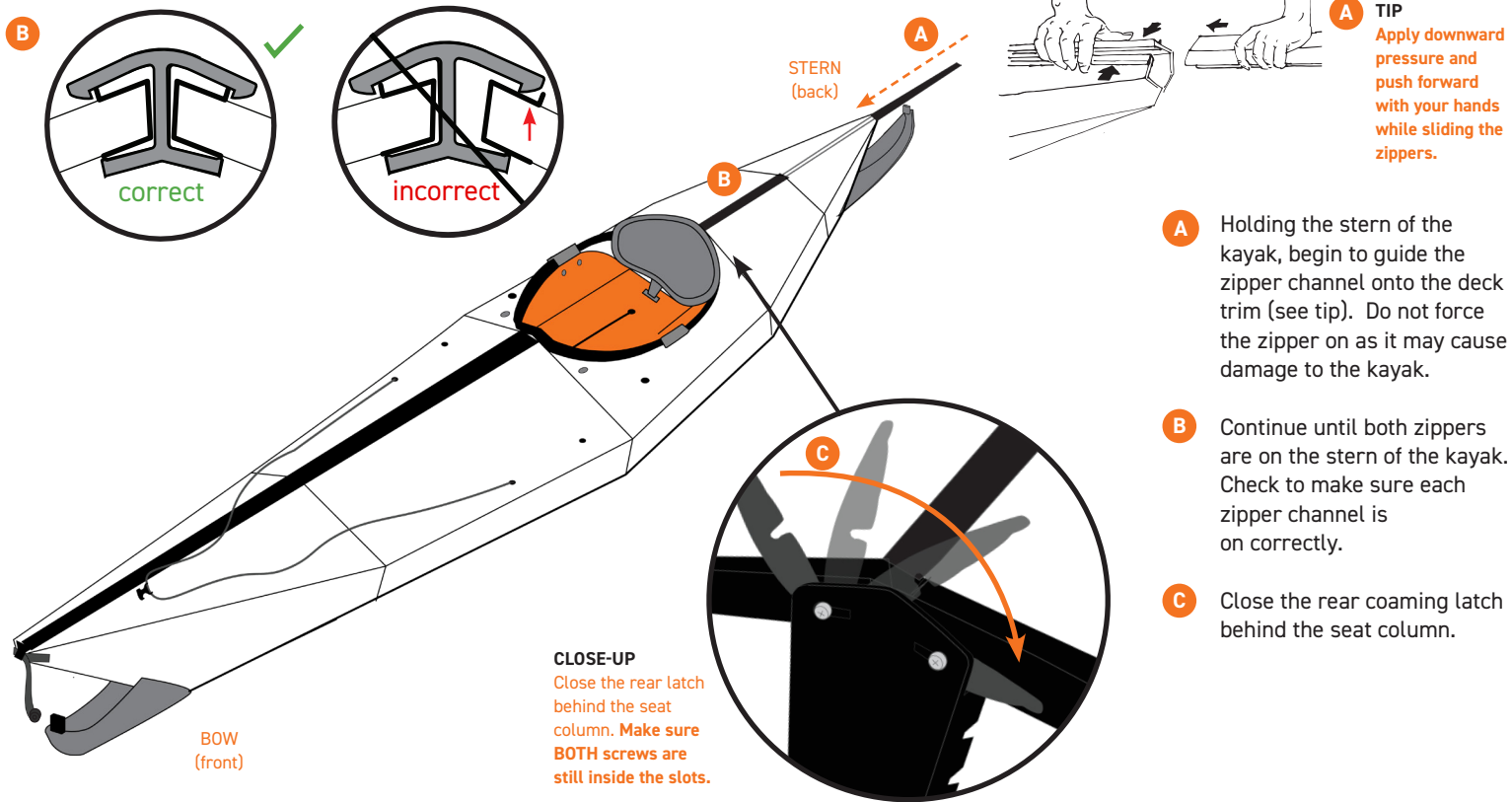

Step 9: Add finishing touches

Just a few more things to get your Oru Kayak ready for the water!

- A** Using the foam block attached to the end straps, plug the small opening on the bow and stern of the kayak.
- B** Stretch the neoprene fairings over the bow and stern and clip the buckles to the buckle on the deckline. Tighten the strap until the decklines are tensioned.

BOW
(front)

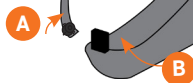

NOTE

If the fairings won't stretch over, make sure the ends are inverted (see 5A).

CLOSE-UP
Step D and E

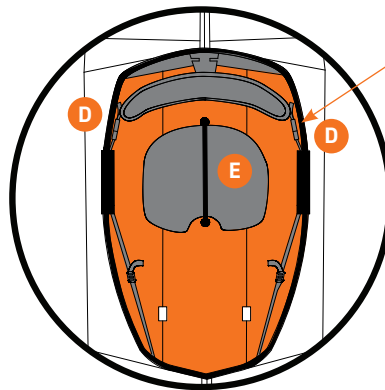

NOTE

Use buckles to adjust backrest and leave space for more comfort.

STERN
(back)

- C** Stretch the bungee across the deck in front of the cockpit (standard positions shown). You may configure the clips as you see fit).
- D** Buckle the seat back straps to the stern-side straps on the coaming.
- E** Slip the seat pad under the bungee on the floorboard.

Final adjustments

BEFORE YOU GET IN:

LOOSEN THE FOOTREST

This will allow easy entry.

ADJUST THE HEIGHT OF THE BACKREST

Move the bungee up or down the notched backrest column to support your lower back.

Pull on the seat back straps to adjust the reclining angle of the seat. When properly adjusted, there should be a space between the seat back and the rear of the coaming, while seated in a normal position.

ONCE YOU'RE IN:

ADJUST THE FOOTREST

From a seated position, move the footrest by loosening or tightening the buckles, just below the kayak deck in front of the cockpit handles.

The footrest should keep your legs comfortably bent, with your knees splayed outward.

ONCE YOU'RE IN:

CHECK THE TENSION STRAP

Make sure the tension strap is tightened, as it may have loosened during assembly. It will help make the kayak more rigid.

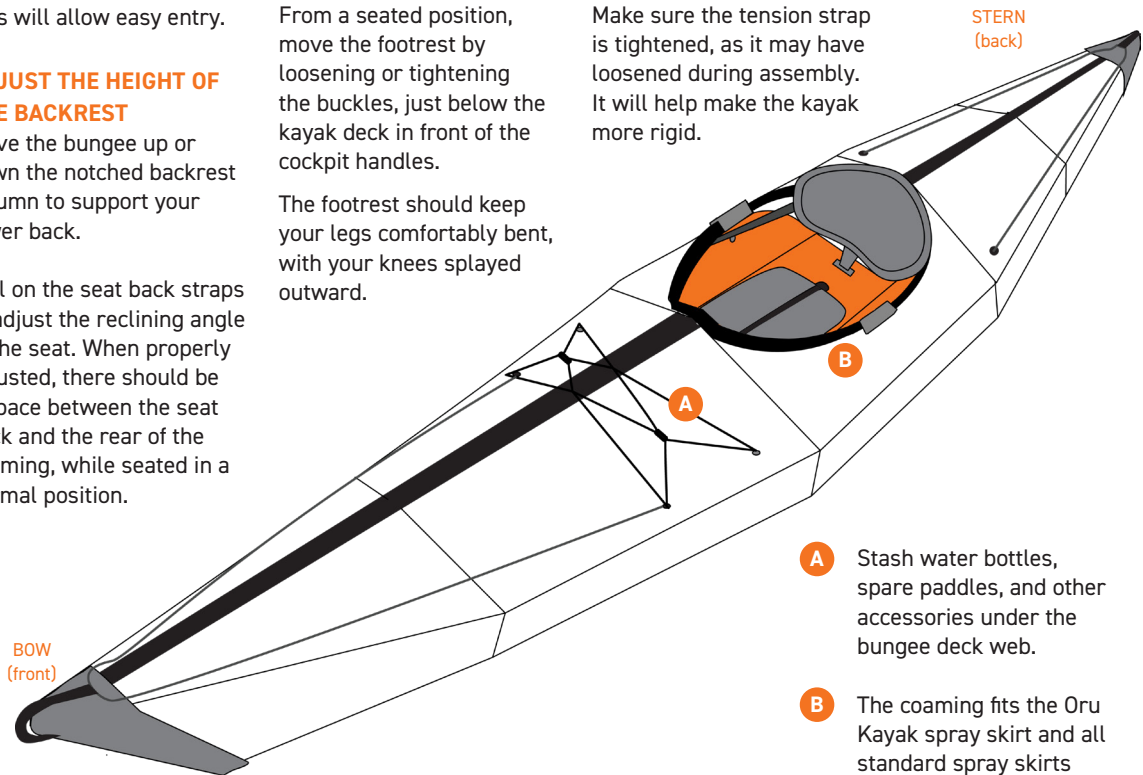

A Stash water bottles, spare paddles, and other accessories under the bungee deck web.

B The coaming fits the Oru Kayak spray skirt and all standard spray skirts (size medium), if desired.

ASSEMBLY CHECKLIST

- Zipper channels are tight and no deck trim is visible underneath.
- Fairings cover both ends.
- Coaming is locked at the front and back of the cockpit.
- Both cockpit handles are locked onto the coaming.

Congratulations!
Your Oru Kayak is ready for the water.



SCAN AND
WATCH ON
YOUR PHONE

Disassembly Guide

BAY ST

TIP:

Some water may collect inside the plastic corrugated flutes.

To let it drain, stand the assembled kayak vertically for about 10 minutes.



Read this entire Assembly Guide before assembling your Oru Kayak.

◀ **IMPORTANT** ▶

Watch the instruction video:
www.orukayak.com/assembly/bayst

SERVICE@ORUKAYAK.COM

Back on land: Folding your Oru Kayak into its box

Disassembling the Oru Kayak is basically a reversal of the assembly, however there are a few tricks.

Follow these simple directions to learn how to pack your Oru Kayak back into its box quickly and easily.

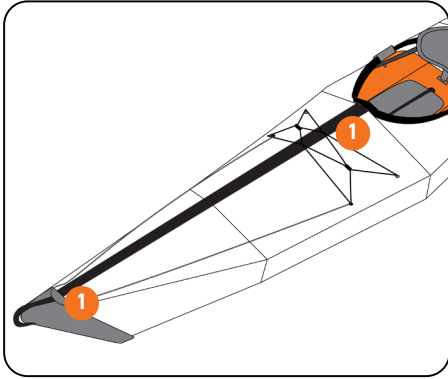

- 1 Moving from bow to stern, unclip the fairings and remove the foam plug. Unbuckle and loosen every side-release buckle and clip. Unbuckle the tension strap. Do not loosen the end straps yet.

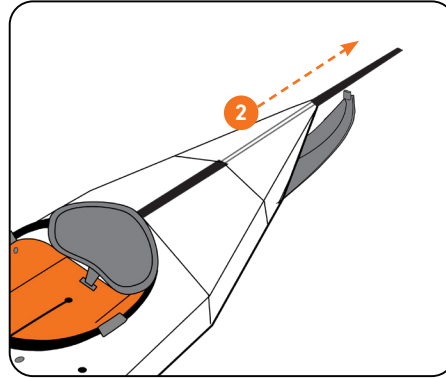

- 2 Unlatch the coaming latches and remove all four zippers from the deck of the kayak.

- 3 Fully loosen the end straps **after** removing the zippers.

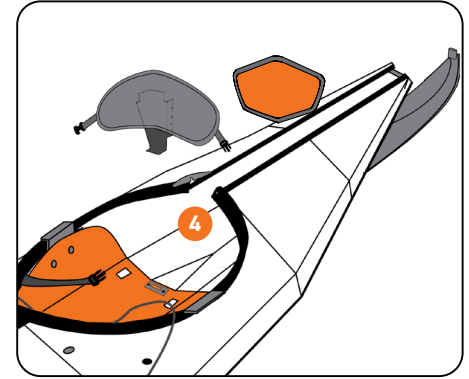

- 4 Remove seatback, seat pad and stern bulkhead.

**FOR STEP-BY-STEP VIDEO INSTRUCTION
WATCH THE ASSEMBLY VIDEO:**

www.orukayak.com/pages/assembly

Back on land: Folding your Oru Kayak into its box

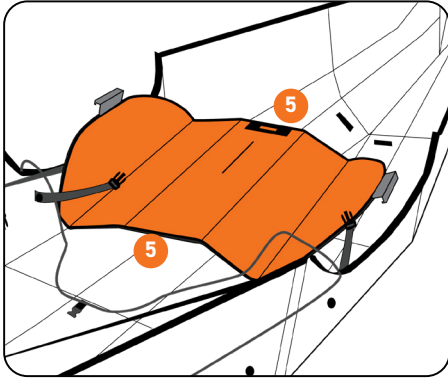

- 5** Remove the floorboard by lifting up from the center sides on the rubber trim indicated in the illustration above. Do **not** use the bungee to remove the floorboard.

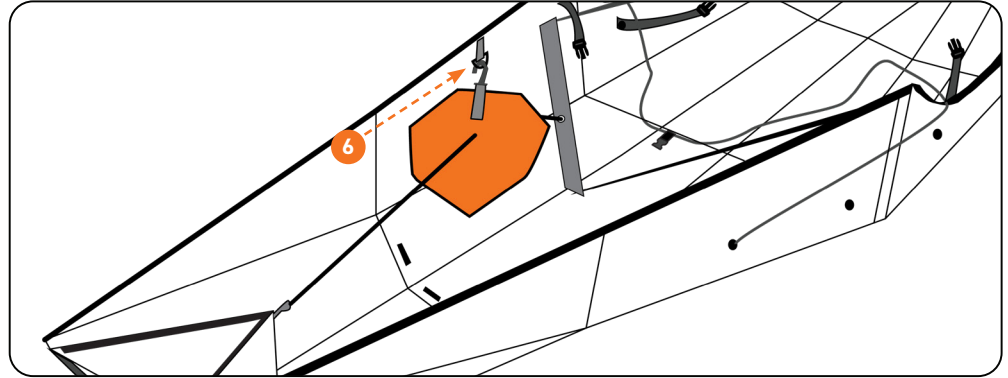

- 6** The bow bulkhead stays in the kayak. Hook it onto the gray ring strap as shown. This keeps the bulkhead and footrest safely out of the way when folding up the kayak

NOTE

Failure to do this step may damage the bulkhead when folding the kayak.

Back on land: Folding your Oru Kayak into its box

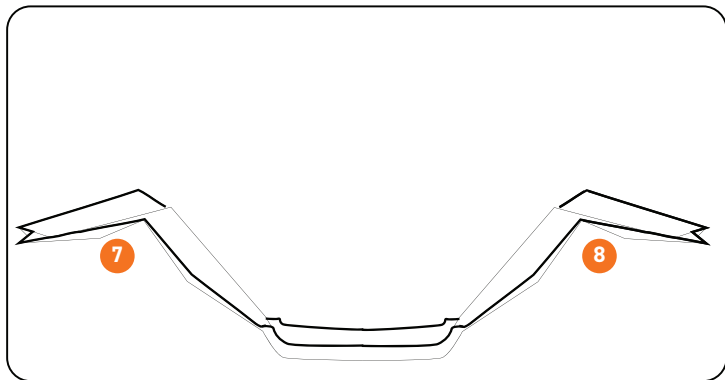

- 7 Fold one end inward, compressing it like an accordion (you can start with the bow or stern). It may help to push inward with your knee.
- 8 Repeat with the other end.

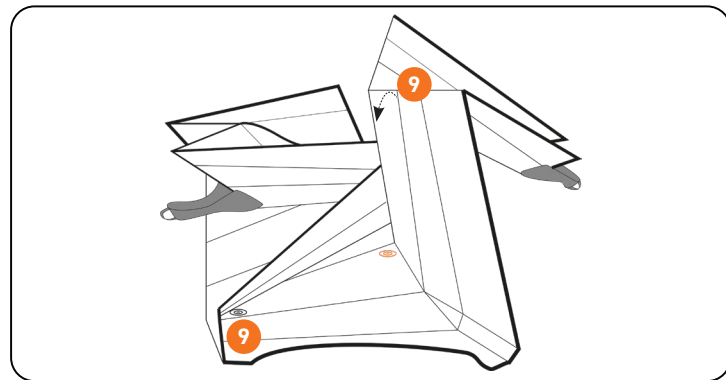

- 9 Push the black arrow towards the black target, and the orange arrow towards the orange target until box is formed. The two folded sides will slide past each other.

Back on land: Folding your Oru Kayak into its box

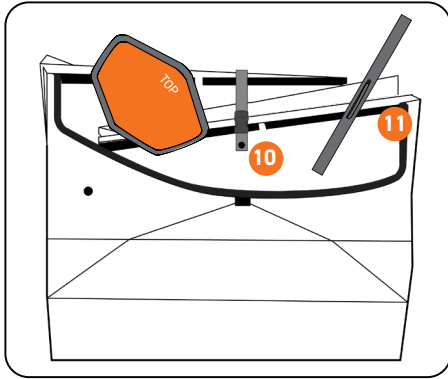

10 Clip and tighten the center grey strap.

11 Stash loose components throughout the box, making sure that they're safely positioned.

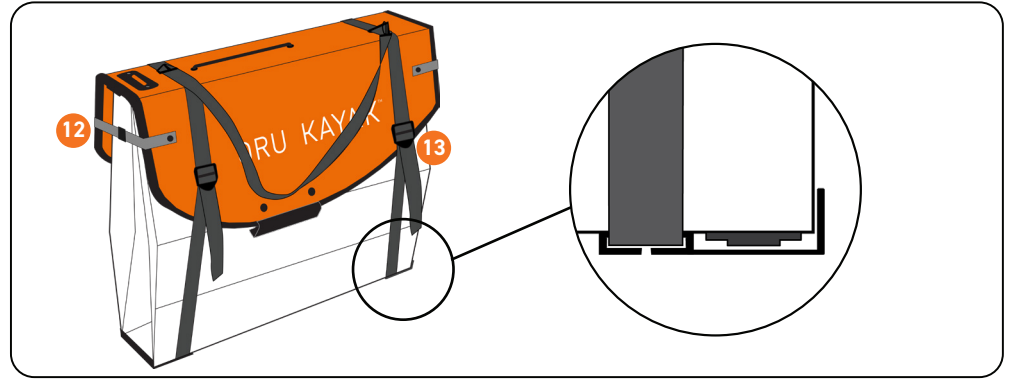

12 Place the floorboard over the top of the box. Connect and tighten the grey straps on either side.

13 Place and tighten the shoulder strap loops over the box.

NOTE

These steps may be tricky, especially when your kayak is brand new. It can help to use your legs to assist in closing the box and install the lid - watch the assembly video for tips.

WE ARE HERE TO HELP

For product or assembly
questions contact us:

service@orukayak.com
(415) 630-3717

ORU  KAYAK

