

PSSE Tall Bench Assembly Instructions

Material and Hardware:

- (A): [8] 1.5" silver #6 screws
- (B): [1] top
- (C): [1] middle member
- (D): [2] legs

Tools Required:

- Electric Drill/Impact with Phillips Bit
- Wood Glue*

Step 1: Align center with legs 1 and 2 slots and insert (4) screws.

Step 2: Align lower assembly into slots on top and insert (4) screws.

Note: when installing any screws into pre-drilled holes make sure they are straight/level and not at an angle to prevent the tip of the screws from poking through any pieces.

Recommended to add a small amount of wood glue to each of the slots

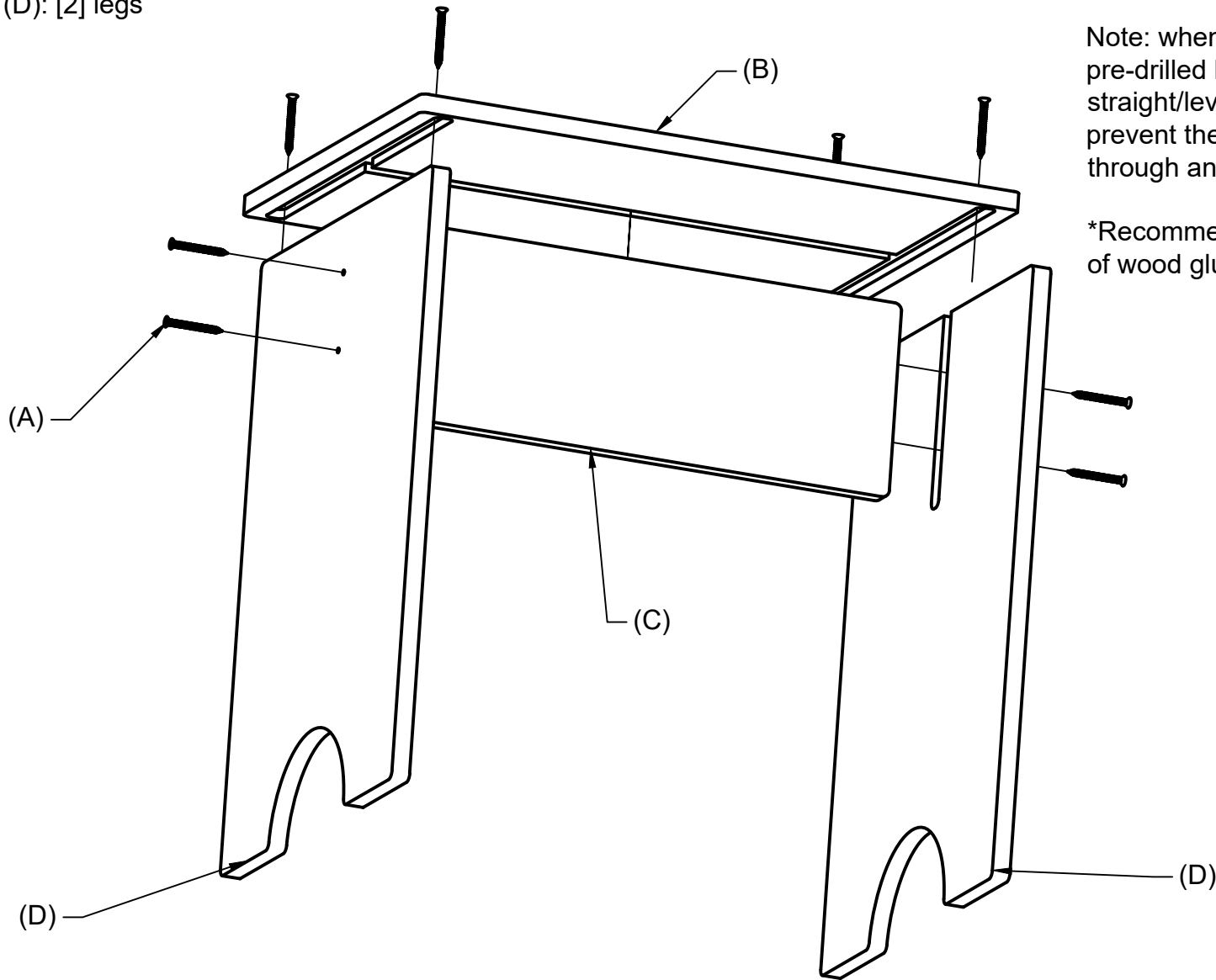

At Beyond Balance customer service is our top priority. If at any time you have any questions, comments or concerns please reach out to us at: 281-813-9999 or info@beyond-balance.net

BEYOND
BALANCE

Follow and tag us at:



@GoBeyondBalance

Use of our products is at your own risk. By purchasing this product you are assuming all responsibility for your own safety. As with all exercise equipment, any misuse of this product can result in injury, and by purchasing this product you agree that you are liable for any action taken with the product. Buyer understands and agrees that the use of the goods purchased from Beyond Balance may be dangerous to human safety, may result in injury or death and present a risk of damage to property if not used properly. You must routinely inspect your equipment for any wear or tear which can occur after repeated use. We are not responsible for any mishaps, injuries or damages resulting from your use of our products. As with any training program or other physical activity performed on these items, there is a risk of injury and proper supervision is required. Purchaser assumes responsibility and acknowledgment of all risk factors. For more training and safety information, we recommend online information from qualified coaches, trainers, and therapist or bringing some of your equipment to your gym/coach/trainer/therapist.