











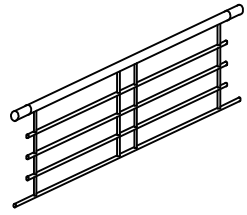
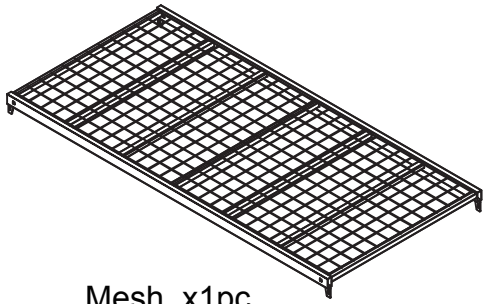

# ASSEMBLY INSTRUCTIONS

## ATL30 – ATLANTA MESH BED

|  |   |   |   |   |   |   |   |
|--|---|---|---|---|---|---|---|
| 1  | 2   | 3   | 4   | 5   |   |   |   |
|   |  |  |  |  |   |   |   |
| Left<br>Head end post<br>x1pc  | Right<br>Head end post<br>x1pc  | Left<br>Foot end post<br>x1pc   | Right<br>Foot end post<br>x1pc  | Head end/Foot end<br>x2pcs  |   |   |   |
| 6  | A   | B   | C   | D   | E   | F   | G   |
|  |  |  |    |   |  |  |  |
| Mesh x1pc  | Bolt<br>M6x100<br>4pcs  | Bolt<br>M6x70<br>4pcs   | Bolt<br>M6x15<br>8pcs   | Insert<br>nut<br>4pcs   | Allen<br>key 4MM<br>1pc   | Washer<br>4pcs  | Self<br>adhesive<br>friction<br>4pcs  |

1

PLEASE NOTE: If your bed legs are placed onto a wooden floor, or any type of flooring that is deemed as 'slippery', it is your responsibility to ensure that the protective rubber or plastic on the base of any legs associated with the bed frame have not worn away. Unless your bed frame is physically fixed to the floor in any way, it is highly likely your bed frame will move as you enter and leave your bed.

If you find that upon checking the legs the rubber or plastic has worn away, you should ensure that some kind of floor protection is placed underneath the legs, such as adhesive floor pads. We highly recommend using floor protection pads with a high adhesion level.

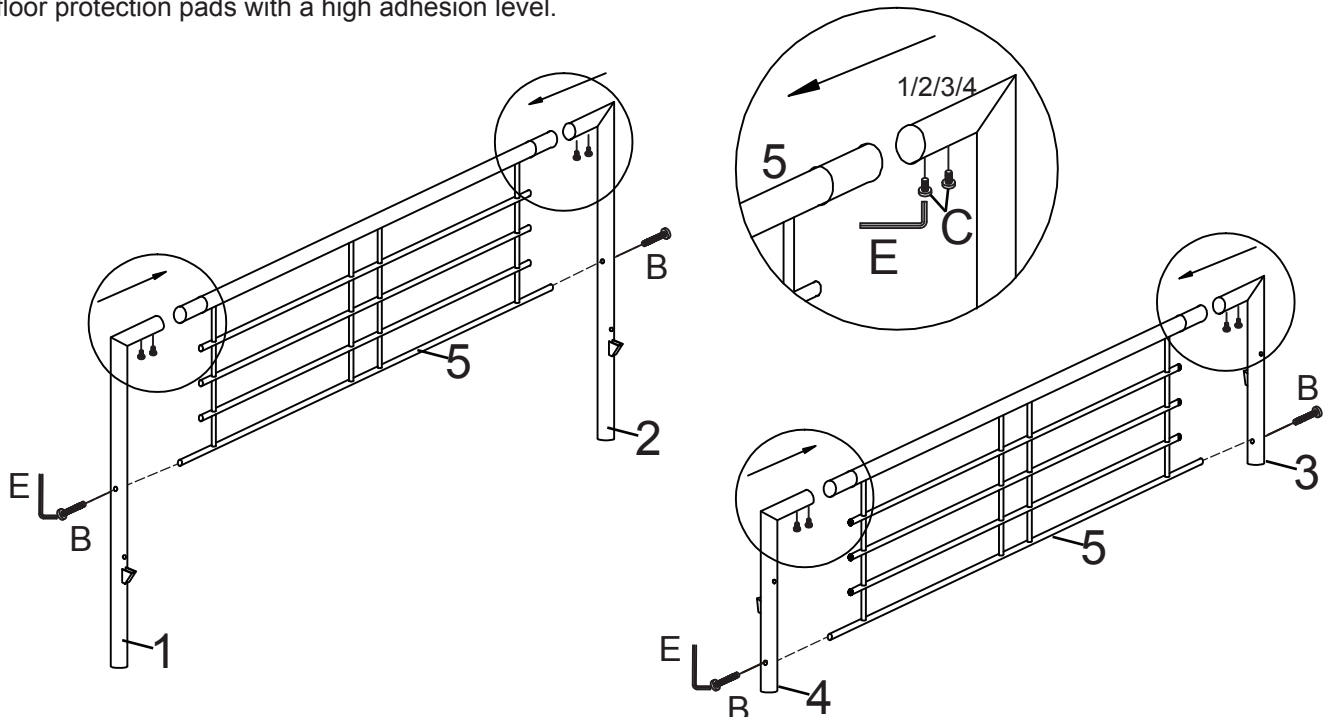

2

2

1

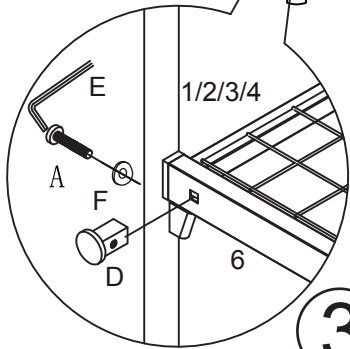
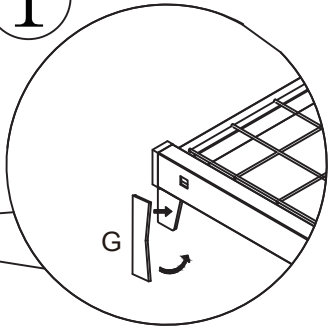
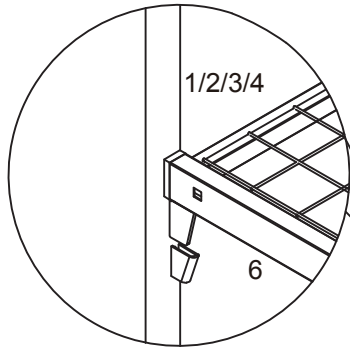

3

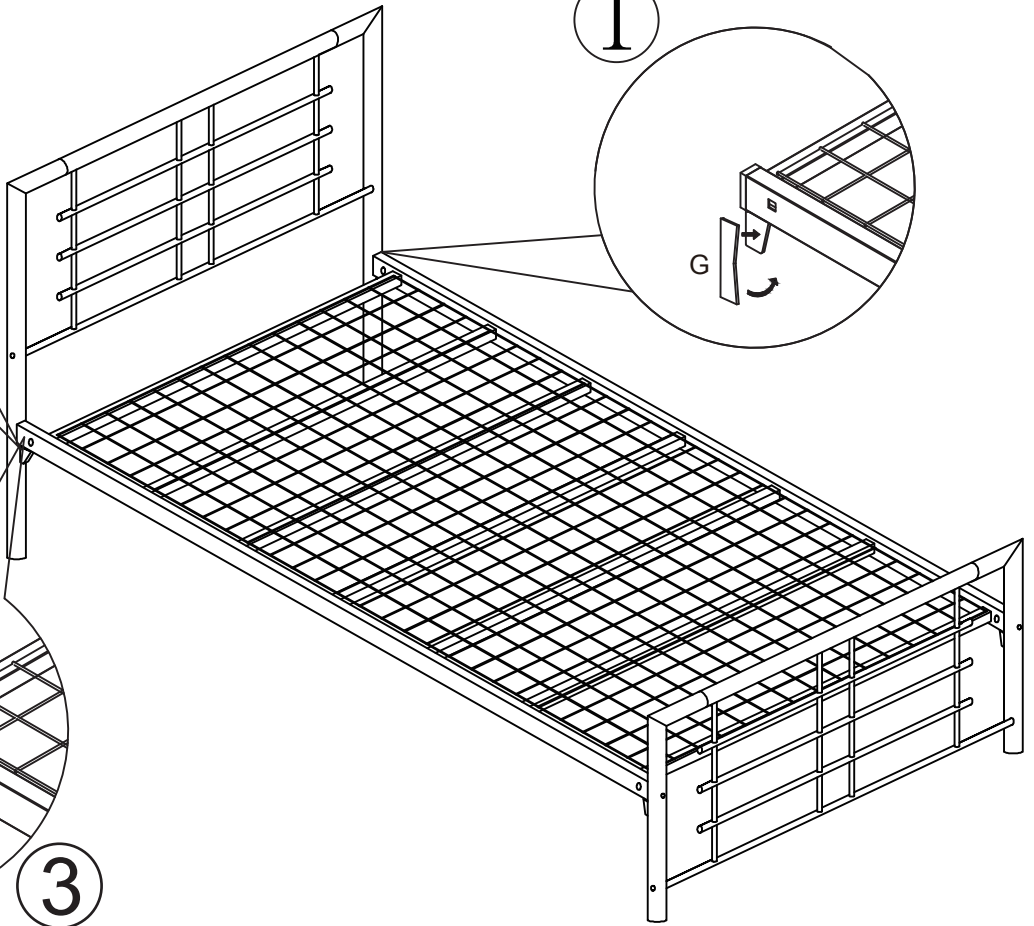



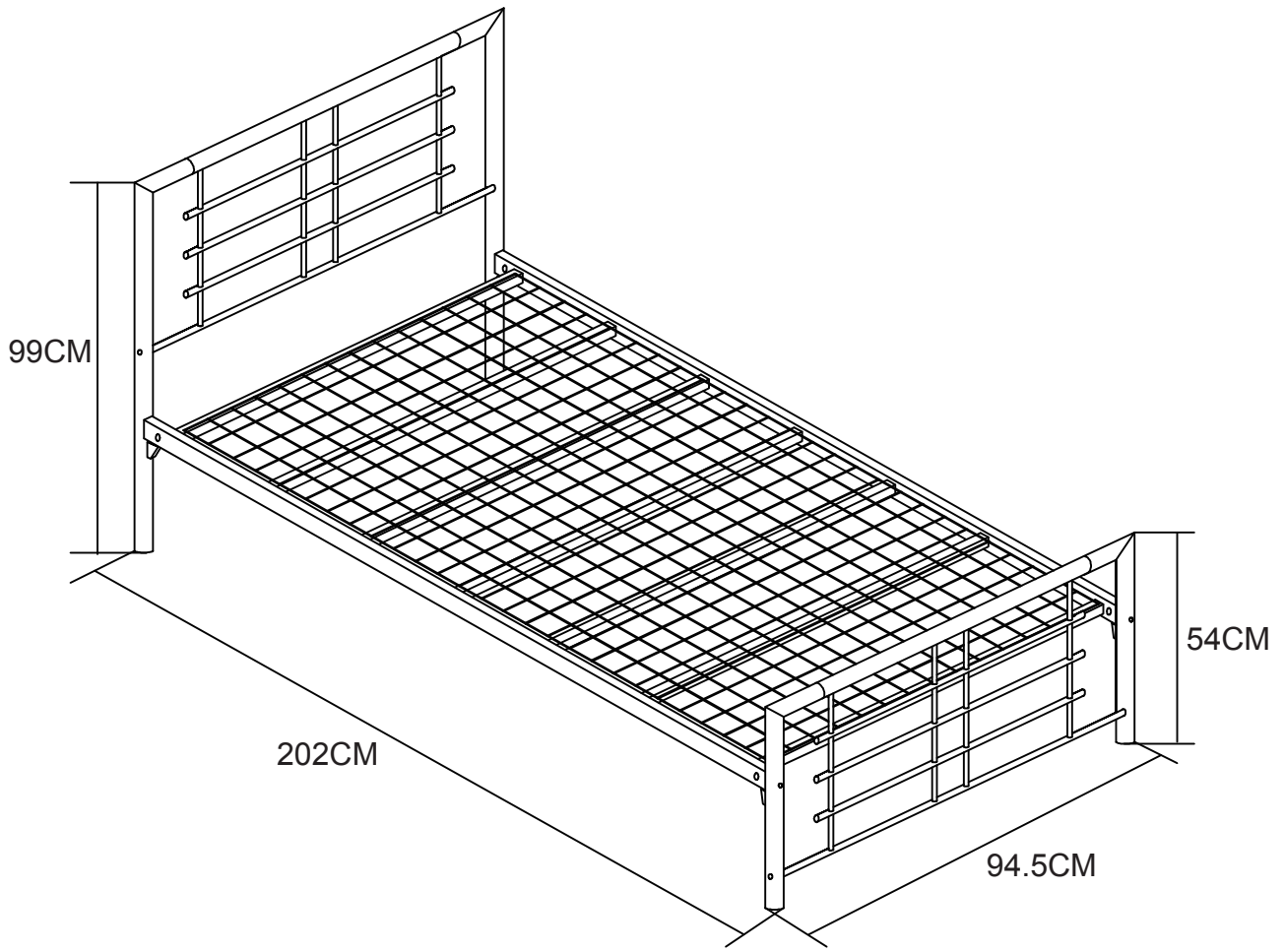





### ATLANTA MESH BED 3'

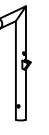
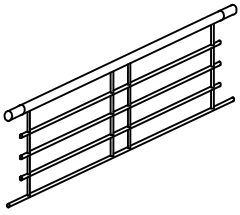
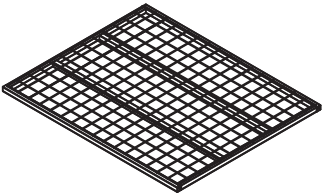
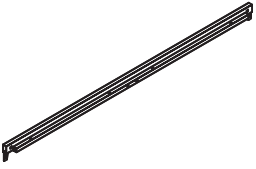
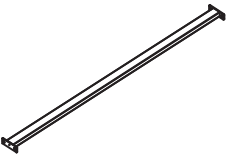
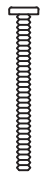
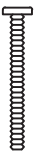
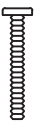

# ASSEMBLY INSTRUCTIONS

## ATL40/46/50 – ATLANTA MESH BED

|   |   |   |   |  |   |   |  |   |   |   |   |
|---|---|---|---|--|---|---|--|---|---|---|---|
| 1   | 2   | 3   | 4   | 5  | 6   |   |  |   |   |   |   |
|  |  |  |  |  |  |   |  |   |   |   |   |
| Left<br>Head end post<br>x1pc   | Right<br>Head end post<br>x1pc  | Left<br>Foot end post<br>x1pc   | Right<br>Foot end post<br>x1pc  | Head end/Foot end<br>x2pcs   | Mattress bed frame x2pcs  |   |  |   |   |   |   |
| 7   |   | 8   |   | A  | B   | C   | D  | E   | F   | G   | H   |
|   |   |  |   |   |    |  |  |  |  |  |  |
| Side rail x2pcs   |   | Horizontal rail x1pc  |   | Bolt<br>M6x100<br>4pcs   | Bolt<br>M6x70<br>4pcs   | Bolt<br>M6x35<br>8pcs   | Bolt<br>M6x15<br>12pcs   | Insert<br>nut<br>4pcs   | Allen<br>key 4MM<br>1pc   | Washer<br>4pcs  | Self<br>adhesive<br>friction<br>4pcs  |

### 1

PLEASE NOTE: If your bed legs are placed onto a wooden floor, or any type of flooring that is deemed as 'slippery', it is your responsibility to ensure that the protective rubber or plastic on the base of any legs associated with the bed frame have not worn away. Unless your bed frame is physically fixed to the floor in any way, it is highly likely your bed frame will move as you enter and leave your bed.

If you find that upon checking the legs the rubber or plastic has worn away, you should ensure that some kind of floor protection is placed underneath the legs, such as adhesive floor pads. We highly recommend using floor protection pads with a high adhesion level.

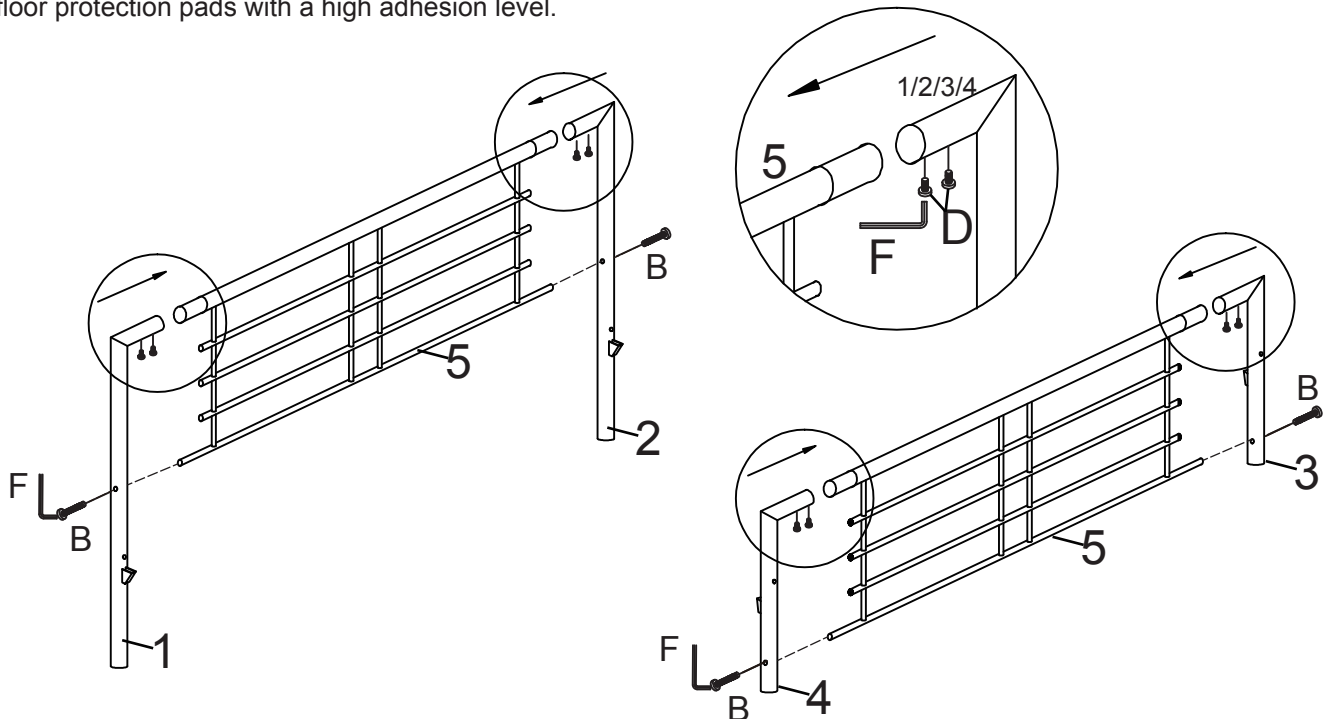

2

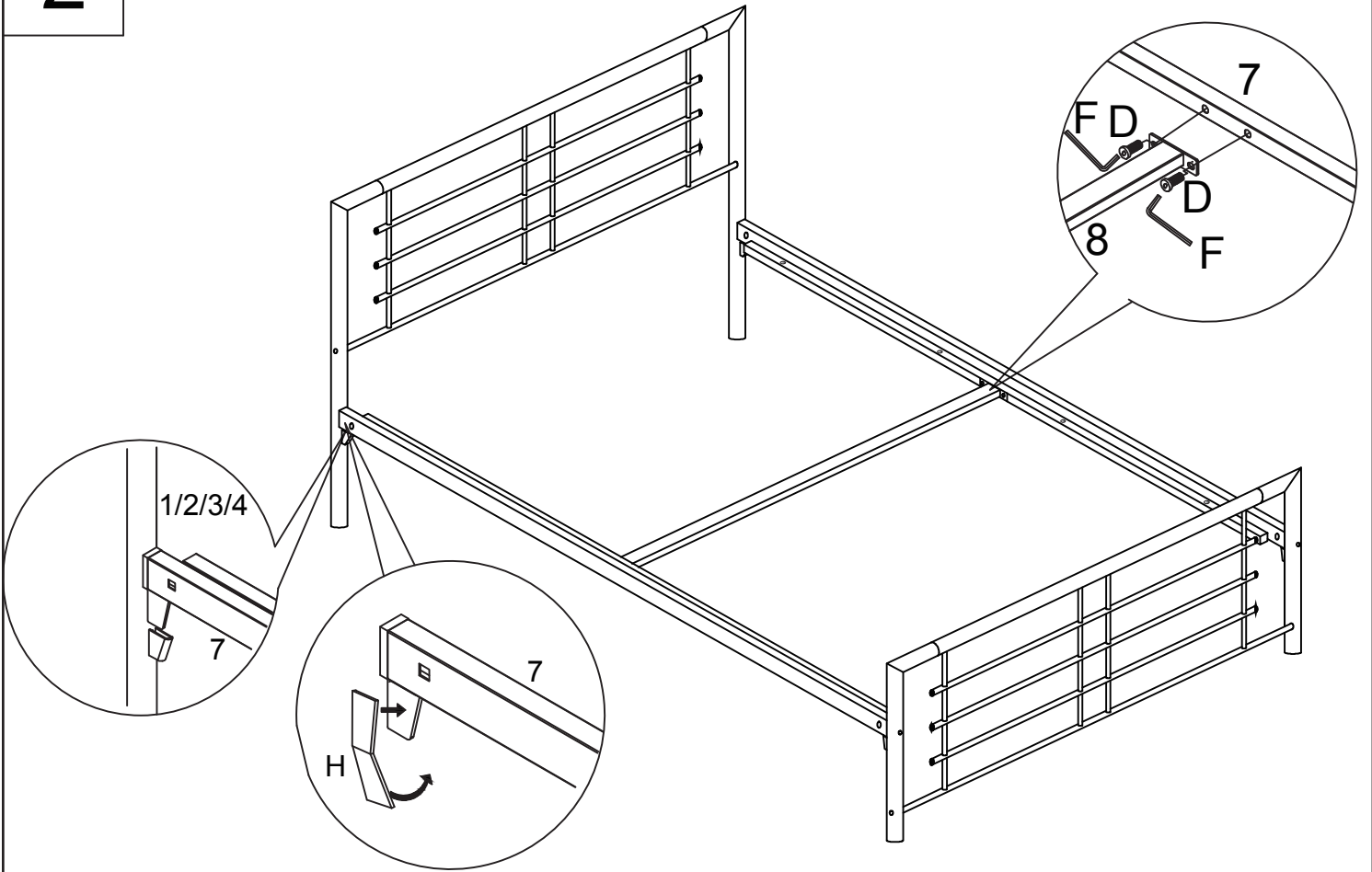

3

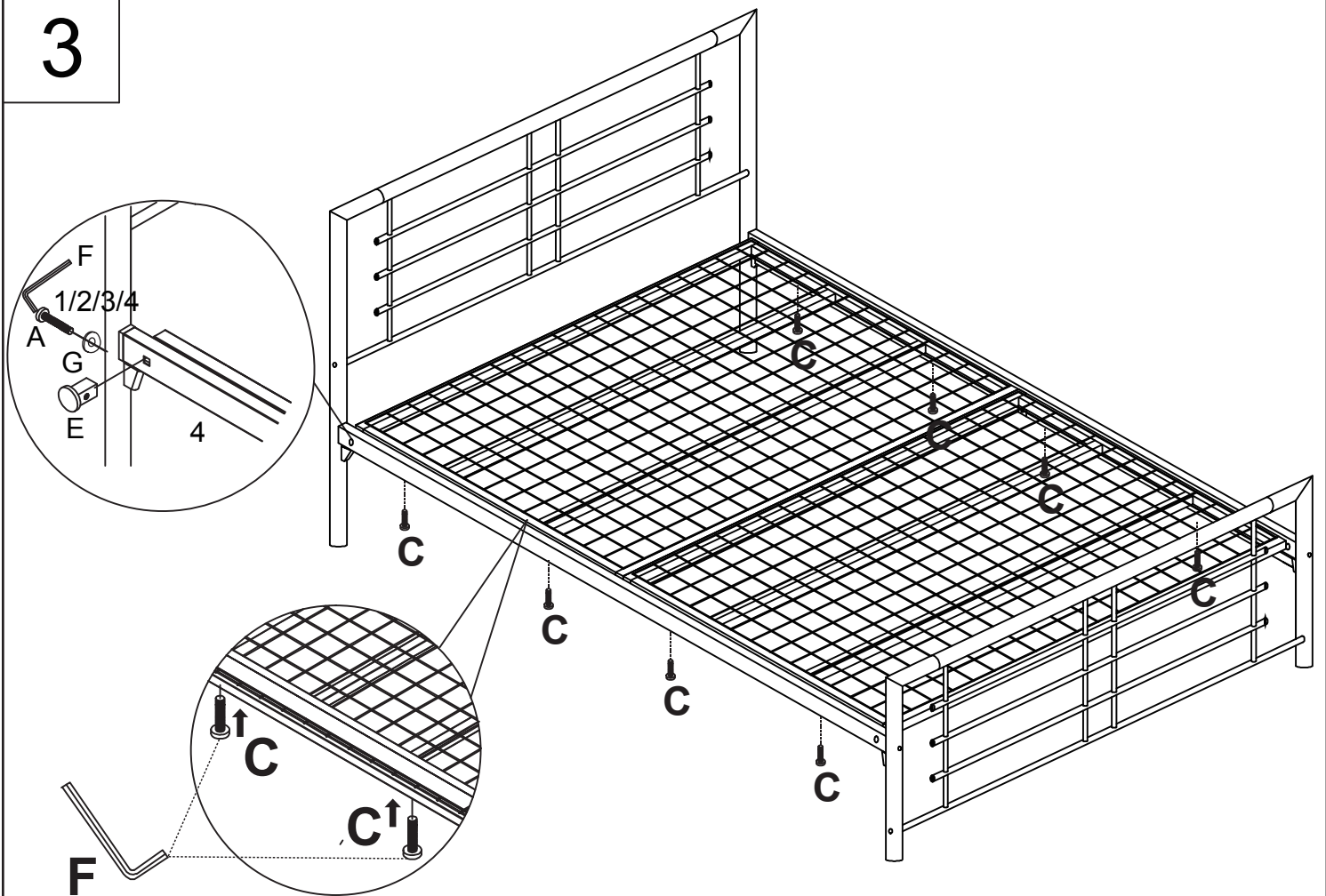

# ATLANTA MESH BED 4'

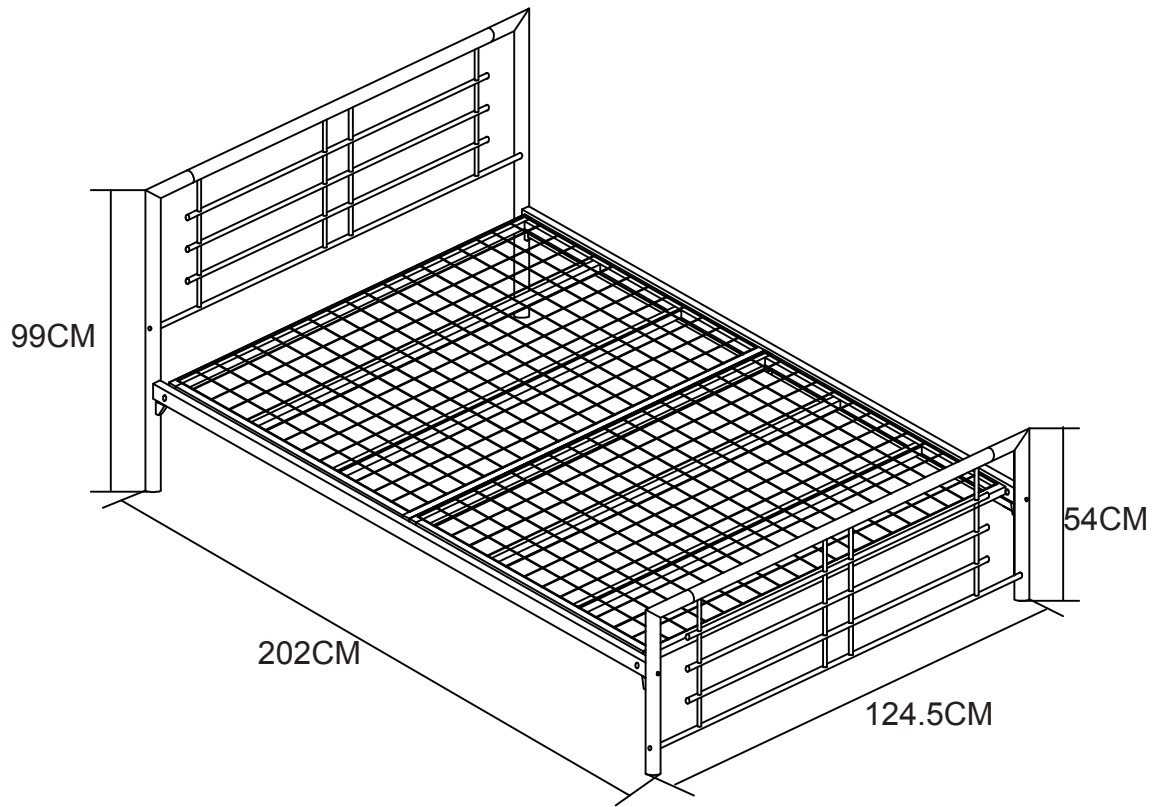

# ATLANTA MESH BED 4'6"

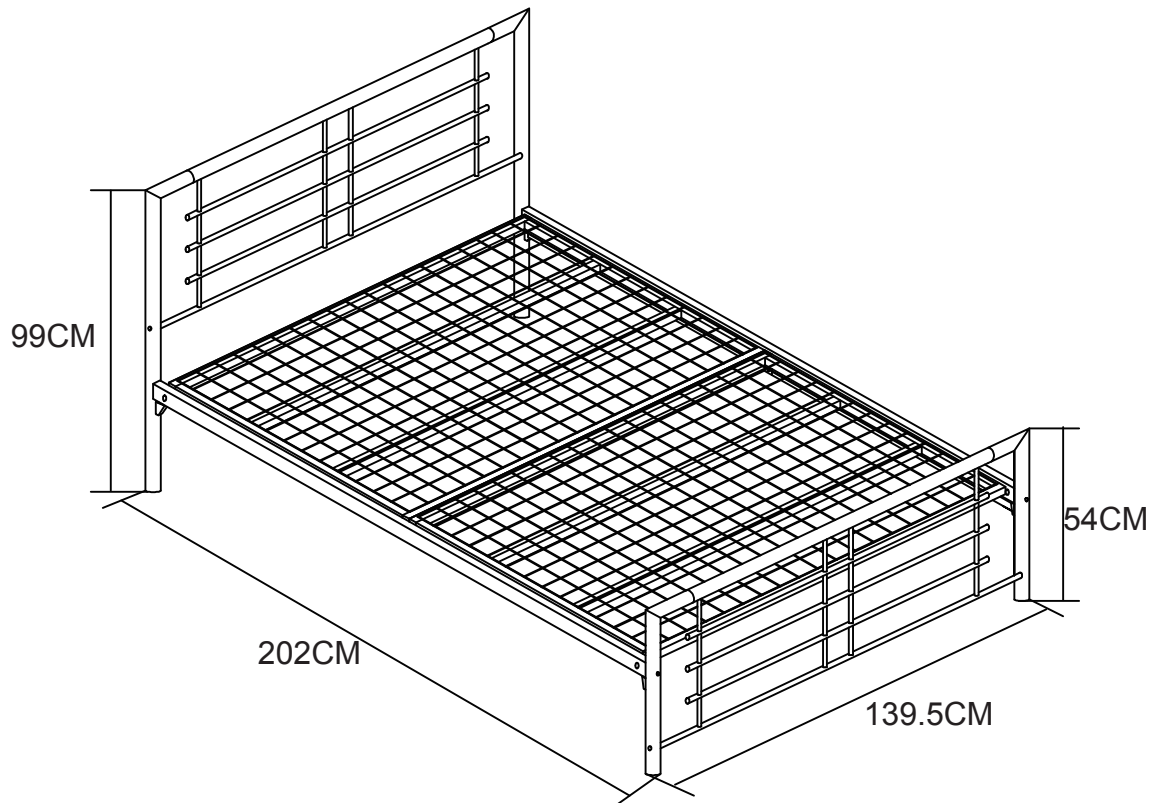

# ATLANTA MESH BED 5'

