

# guzzle H2O

pure water. no trash.

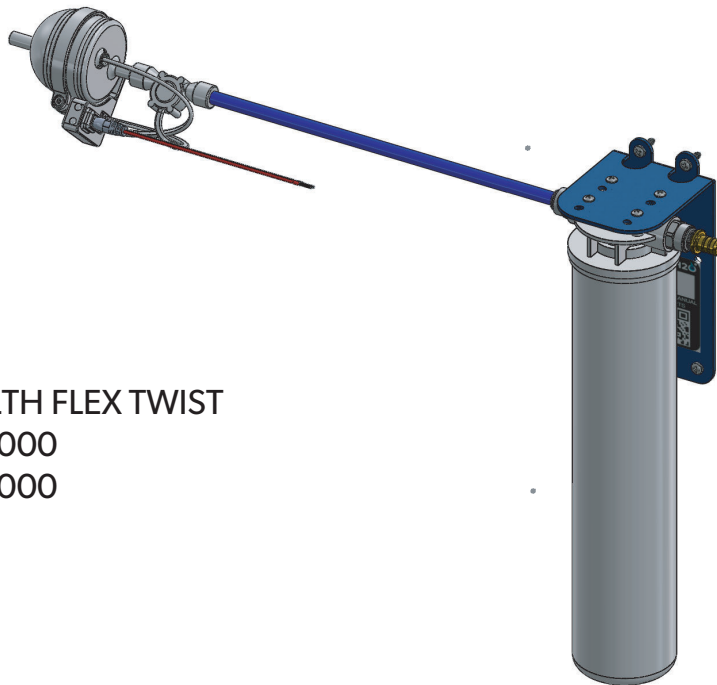

STEALTH FLEX TWIST  
515-0000  
513-0000

## INSTALLATION / OPERATION MANUAL

### STEALTH FLEX TWIST

### REV A

GUZZLE H2O LLC    [WWW.GUZZLEH2O.COM](http://WWW.GUZZLEH2O.COM)    [INFO@GUZZLEH2O.COM](mailto:INFO@GUZZLEH2O.COM)

363 JEWETT BLVD, WHITE SALMON, WA 98672 USA

EMAIL SUPPORT AT [INFO@GUZZLEH2O.COM](mailto:INFO@GUZZLEH2O.COM)

# STEALTH FLEX USERS MANUAL

**guzzle H2O**<sup>®</sup>  
pure water. no trash.

## STEALTH FLEX USERS MANUAL

### TABLE OF CONTENTS

<b>CONTENTS</b>	<b>PAGE</b>
TABLE OF CONTENTS	1
HAZARD WARNING	2
PART IDENTIFICATION	3
SYSTEM LAYOUT	4
SYSTEM OVERVIEW	5
MOUNTING BRACKET INSTRUCTIONS	6
INSTALLATION INSTRUCTIONS	7
OPERATION	9
BRACKET MOUNTING PATTERN	10
WIRING DIAGRAM	11
HOW TO USE PUSH TO CONNECT FITTINGS	12
UV ORIENTATION	14
INDICATOR LIGHT STATUS CODES	15
CHANGING THE CARBON BLOCK CARTRIDGE	16
WINTERIZATION	17
TIPS AND TROUBLESHOOTING	19
SYSTEM SPECIFICATIONS AND CAPACITIES	20
PARTS, MANUALS, RESOURCES	21

-END OF MANUAL-



## WARNING



### MICROBIOLOGICAL HAZARD

Human consumption of untreated water can lead to exposure to harmful microorganisms and an increased risk of gastrointestinal illness. Operating this filtration and purification device incorrectly increases your risk of exposure to harmful microorganisms and increases your risk of gastrointestinal illness. Reduce your chances of becoming sick by following the warnings and instructions in this operator's manuals.

Guzzle H2O products are designed to reduce unwanted bad taste & odor, chlorine, VOCs, lead, mercury, and other contaminant particles as small as 0.5 micron in size. Guzzle H2O products are 3rd party tested in accordance with US EPA Guidelines for Ultraviolet Disinfection to inactivate 99.99% of viruses, protozoa, and bacteria. Guzzle H2O products do not remove toxins, heavy metals, or treat chemically contaminated water, and will not make potable water from sources with these contaminants. Observe all instructions and specifications in this document. When in doubt, treated drinking water should be tested by the user to verify its safety to consume.

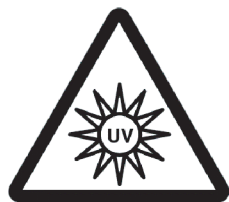

UV exposure  
risk if used  
improperly

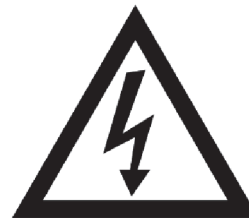

Electrical  
shock  
possible

# STEALTH FLEX USERS MANUAL

**guzzle H2O**  
pure water. no trash.

## PART IDENTIFICATION

ITEM NO.	DESCRIPTION	QTY.
1	FILTER, 0.5 MICRON CARBON BLOCK, TWIST LOCK, ASSEMBLY	1
2	TUBING, 0.375 OD, 0.25 ID, PEX. BLUE	1
3	LED UV CHAMBER, PEARL AQUA 12C, WITH FLOW SENSING SWITCH	1
4	THREAD FORMING SCREW, PHIL ROUND HEAD, NO 8, 0.75 LG SST	4
5	WOOD SCREW, PHIL HEAD, NO 10, 0.75 LG, 316 SST	4
6	MOUNTING BRACKET, FILTER, TWISTLOCK OR SLIMLINE, STEEL, POWDERCOATED	1
7	CAP, TWIST LOCK FILTER MANIFOLD, ACETAL, WHITE	1
8	CABLE ASSEMBLY, 2.1 X 5.5MM PLUG, 2-16 AWG CABLE, FLAT, 15FT LG	1
9	STRAIGHT ADAPTER, 0.375 PTC X 0.375 NTP	2
10	DECAL, DO NOT FREEZE WARING	1
12	DECAL, STEALTH SERIAL NUMBER	2
14	O-RING, 0.949 OD, 0.755 ID, 0.097 THK, SILICONE, FOR TWIST CAP	1
15	CONNECTOR, STRAIGHT, 0.375 PTC X 0.375 PTC, ACETAL, WHITE	1
16	STRAIGHT ADAPTER, .375 TUBE X .5 BARB	2
17	STRAIGHT ADAPTER, .375 TUBE X .375 BARB, ACETAL	2
18	HOSE CLAMP, WORM DRIVE, .5 TO .9 ID, .5 W, .23 THK, SST	2

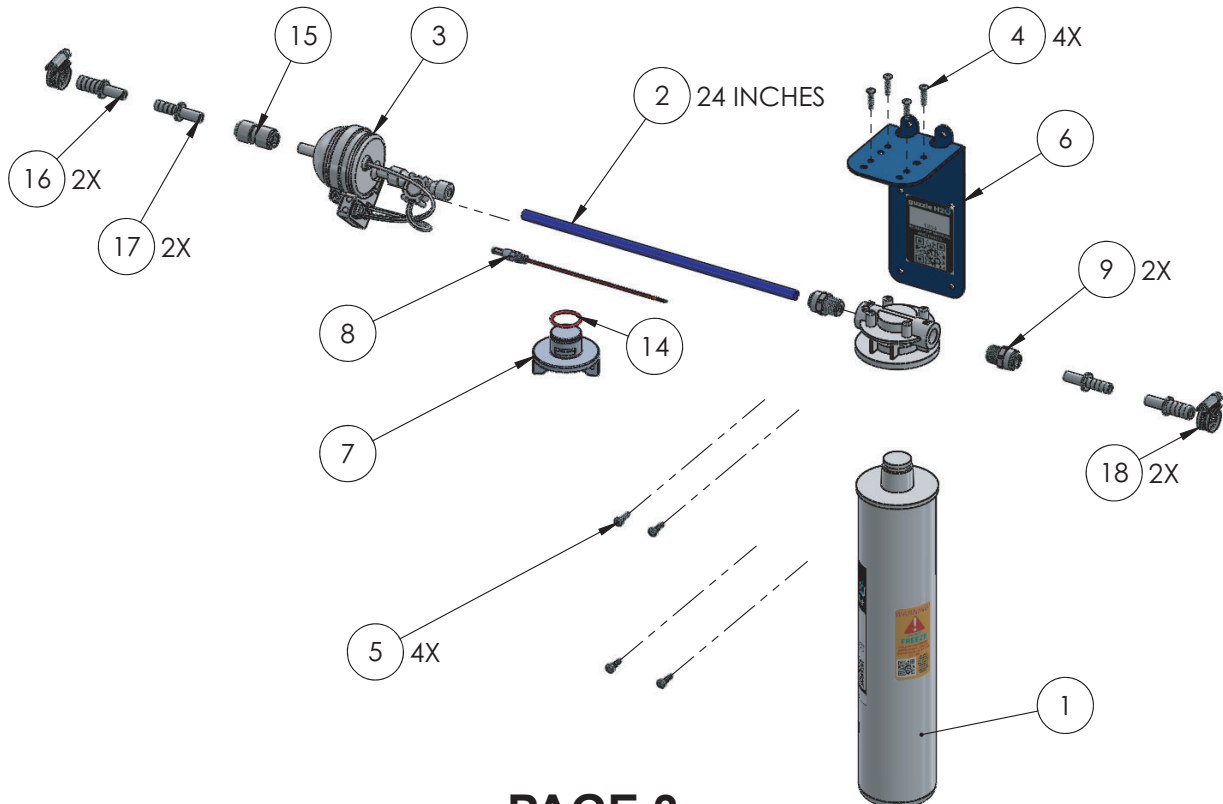

## STEALTH FLEX SYSTEM LAYOUT

### NOTES:

NOTE THE DIRECTION OF WATER FLOW

STEALTH FLEX SYSTEM MAY BE ARRANGED WITH THE INLET ON THE RIGHT OR LEFT SIDE. SEE INSTRUCTIONS FOR REVERSING CARBON FILTER BRACKET PAGE 6.

WATER MUST ALWAYS FLOW TO THE CARBON FILTER BEFORE UV

TUBE SECTION ② MAY BE TRIMMED OR BENT TO ACCOMODATE INSTALLTION.

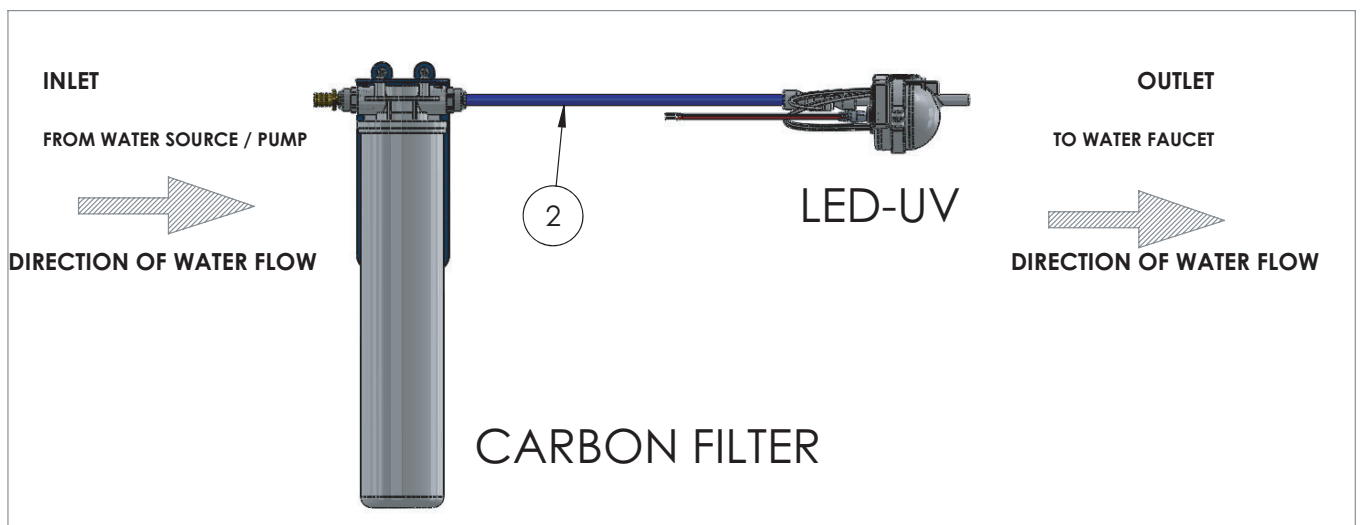

OR

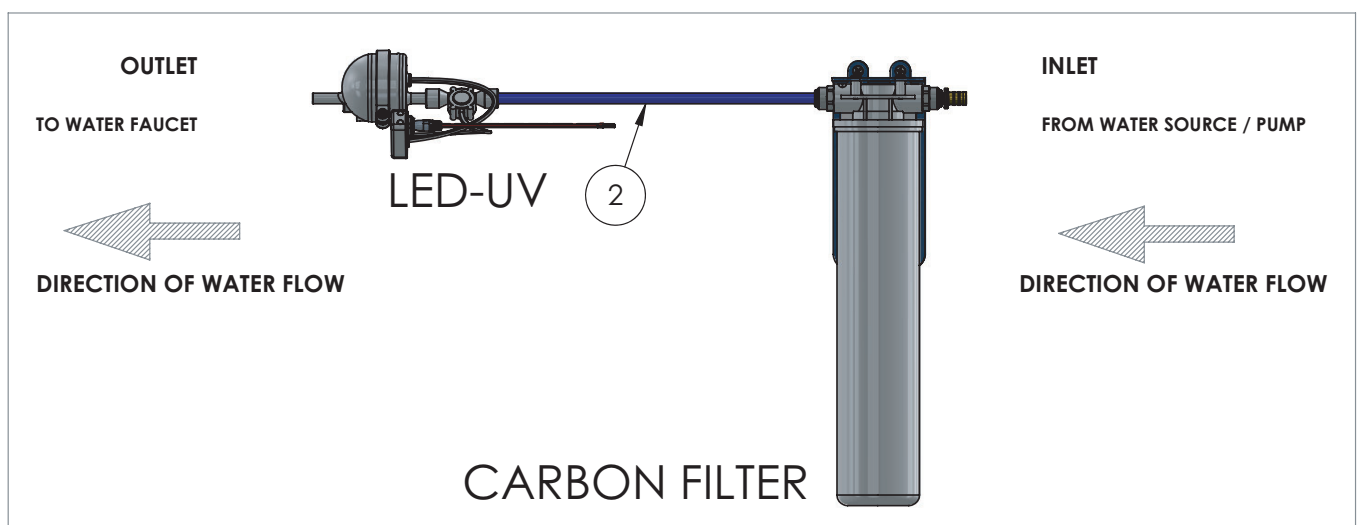

## STEALTH FLEX SYSTEM OVERVIEW

### System Layout:

The Stealth Flex includes a carbon filter and a UV purification chamber. It must be installed with the carbon filter at the water inlet, and the UV at the outlet. See page 4. The Stealth Flex should be installed on the cold water line between the water source, such as the pump or pressure tank, or water line; and the point of use faucet. Ideally the Stealth should be the last component the water passes through before the faucet.

It is optional to provide a dedicated stand alone drinking water faucet for the Stealth Flex system. Operator preference should dictate this decision. Considerations include a slight pressure drop associated with the carbon filter, and if a fully isolated water purifier is required.

### Mounting:

The Stealth Flex can be mounted to configure the inlet on the Right or Left side of the system. Note that the Mounting Bracket (6) must be arranged to provide the inlet to the Carbon Filter on the desired side. See instructions on Page 6 for reversing the Mounting Bracket if necessary.

### Electrical Supply

The Stealth requires 12v power supply, drawing 1 amps when activated. Alternately a 12V power adapter can be used to connect to 110V.

### Operation:

The Stealth Flex has a instantaneous flow sensing switch which detects water flow and immediately activates the UV. The Stealth Flex will sense that water is moving when you open the faucet. The sensor will notice a minimum of 0.3 litres per minute flow rate. LED technology allows it to instantly switch ON the UV chamber to full power and effectiveness with no warm up necessary. It draws minimal power when it is in standby mode.

## MOUNTING BRACKET INSTRUCTION

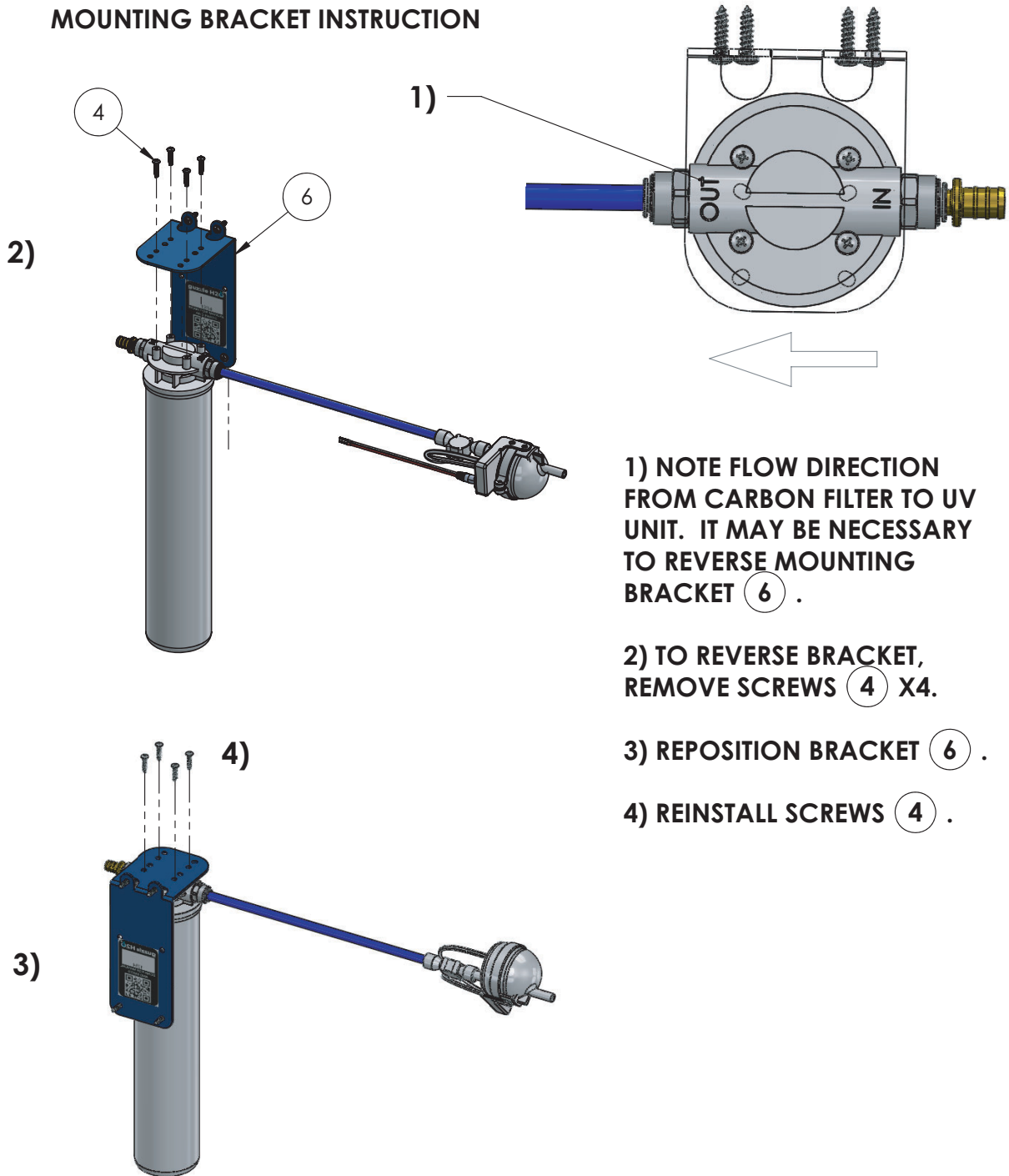

## STEALTH FLEX INSTALLATION

Tools required:

No 2 Philips Head Screwdriver

Tube Cutter (Optional)

### General Practices

- Read all instructions before use.
- Remove the Stealth Flex from Packaging, ensure contents are complete.
- Do not power on UV without water connected and initial flushing.
- For installation location, consider ease of access for filter changes, minimum bend radii of tubing, and access to electrical connections.
- Do a quick test fit before beginning installation.
- Use appropriate connection fittings compatible with the inlet and outlet fittings.

### Instructions

1) Turn off water supply, and/or all pumps supplying pressure to the water system.

2) Determine plumbing layout. Stealth may be mounted with inlet on the right or left hand side of the unit. See Page 4,5 and 6. Plan for adequate space for inlet and outlet plumbing to have a clean approach, and to be secured to minimize movement and vibration when installation is complete. PEX tube (1) may be trimmed using Tube Cutter, or may bend to fit irregular spaces and installations.

3) Install Filter Mounting Bracket (6) to top of filter housing for Right or Left inlet. Note IN and OUT sides of filter. IN should come from water supply, and OUT should connect to PEX tube (1) and on to UV Unit (3). See Page 4 and 6.

4) Remove Carbon Filter (1) and set aside.

(5) Holding Filter Mounting Bracket (6) in place, attach to wall with provided Wood Screws (5) using No 2 Philips Head Screwdriver. Screws are self tapping. Do not over-tighten screws, substrate material may strip if over-tightend. If mounting in a material other than wood, metal, or plastic, substitute appropriate fasteners.

6) Push PEX Tube (2) into Filter OUT connection. See instructions Page 11 for using Push To Connect Fittings. Once connected, pull on the tube to tension the Push To Connect fitting to create seal.



## STEALTH FLEX INSTALLATION (CONTINUED)

7) Remove blue clip on flow sensor. Push other end of PEX Tube (2) into Flow Sensor side of UV unit(3). Replace blue clip to secure collar.

8) Select 3/8" (17) or 1/2" (16) Barbed Adapter to fit local plumbing. Supplied Barbed fittings will work with Braided PVC tube, as well as some PEX tubing. For other fittings, see Tips or consult [www.guzzleh2o.com](http://www.guzzleh2o.com). Push barbed fittings into local plumbing, and secure with worm drive hose clamp.

9) Insert stem of Barbed fittings (16 or 17) into INLET of Carbon Filter, and OUTLET of UV unit (3). See Push To Connect Fitting Instructions Page 12 & 13.

10) Connect power cable cable (8) to 12V power supply. RED cable connects to positive (+) terminal. BLACK cable connects to negative (-) terminal. Connect barrel plug to underside of UV unit. Trim power cable length as necessary. See Wiring Diagram Page 11.

11) Secure UV Purification Chamber (3) and PEX tube (2) as necessary to minimize movement. Note correct orientation of UV Purification Chamber (Page 14).

12) Install Carbon Block Cartridge (1). Insert and turn clockwise to lock in place.

13) Turn on water supply. Determine that there are NO LEAKS.

14) Turn on power to UV and test operation. GREEN light indicates power is ON. BLUE light indicates UV system is ACTIVE when water flows. BLUE light should turn off when water flow stops. See Status Light Codes Page 15.

15) Flush carbon fines out of new Carbon Filter. Run 3-5 gallons of water through Stealth Flex to remove carbon fines from new Carbon Filter. You will see black sediment in water as fines are removed.

16) Have a drink of clean water!

## STEALTH FLEX OPERATION

When power is connected to the Stealth, after startup, the green indicator LED illuminates to indicate it is on STANDBY MODE (see page 9). In this mode, the Stealth is ready to purify water, but has not yet activated the UV purification chamber.

The UV purification function of the Stealth activates automatically by sensing water flow and activating the UV purification chamber when water is moving. A few seconds after the water stops, the Stealth turns the purification chamber off. Water flow typically is started and stopped by using your faucet. UV purification activity is indicated by the BLUE LED indicator light. The sensor requires a minimum of 0.3 liters per minute of flow to activate.

LED technology allows the UV purification chamber to instantly activate and perform at full effectiveness. The UV chamber does not require any time to “warm up.”

The Stealth can be left on STANDBY MODE indefinitely. The UV function should only activate when water is running.

### **Pulsecare:**

When the UV unit is in Standby Mode, and water is not flowing, the UV unit will periodically activate to clean the UV chamber. This prevents microbiological pathogens from migrating through the chamber due to natural colonization and transport. While inactive, the UV will flash for 1 second every 30 minutes.

If system is left off for more than 12 hours, contamination from microbiological migration is possible, and water lines should be sanitized.

# STEALTH FLEX USERS MANUAL

**guzzle H2O**<sup>®</sup>  
pure water. no trash.

## STEALTH FLEX BRACKET MOUNTING PATTERN

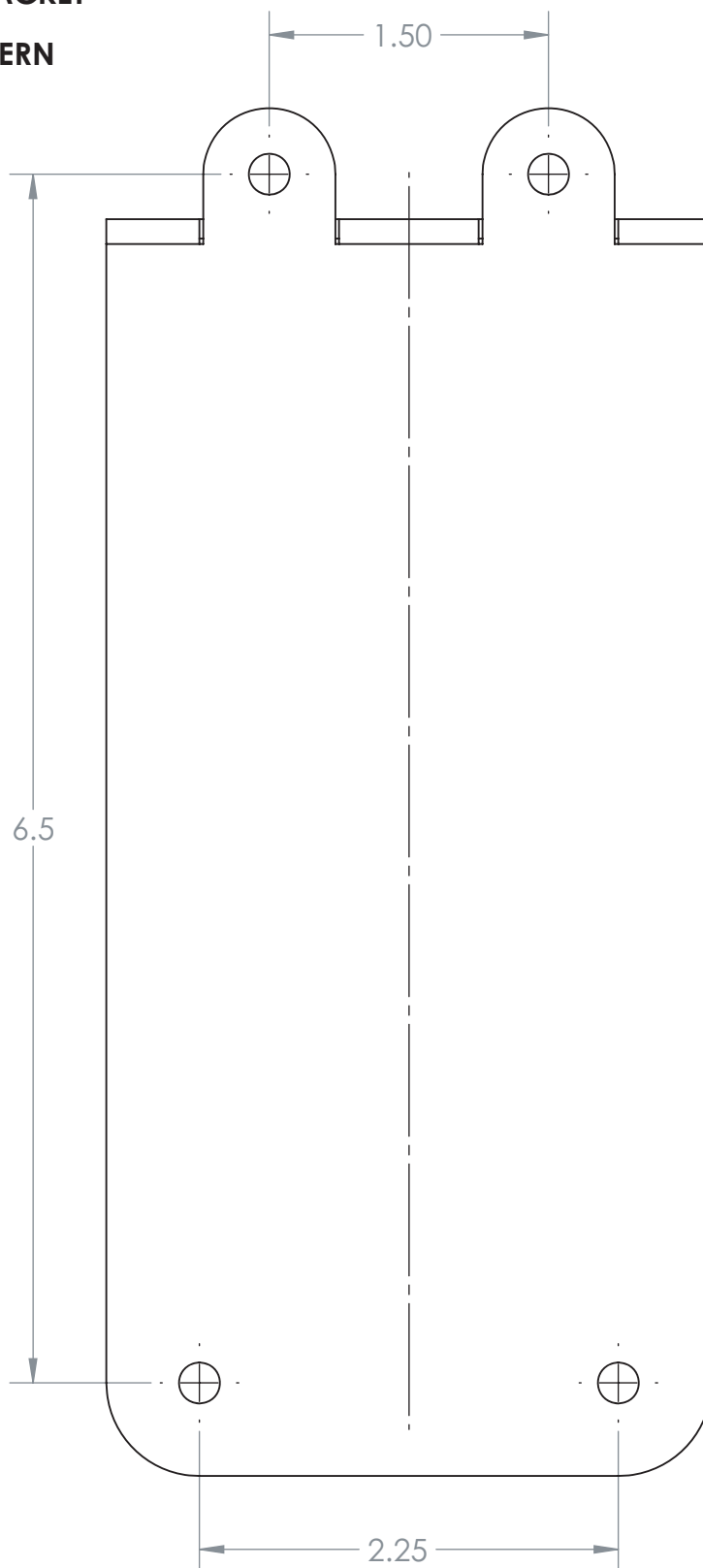

SCALE 1:1

## STEALTH FLEX WIRING DIAGRAM

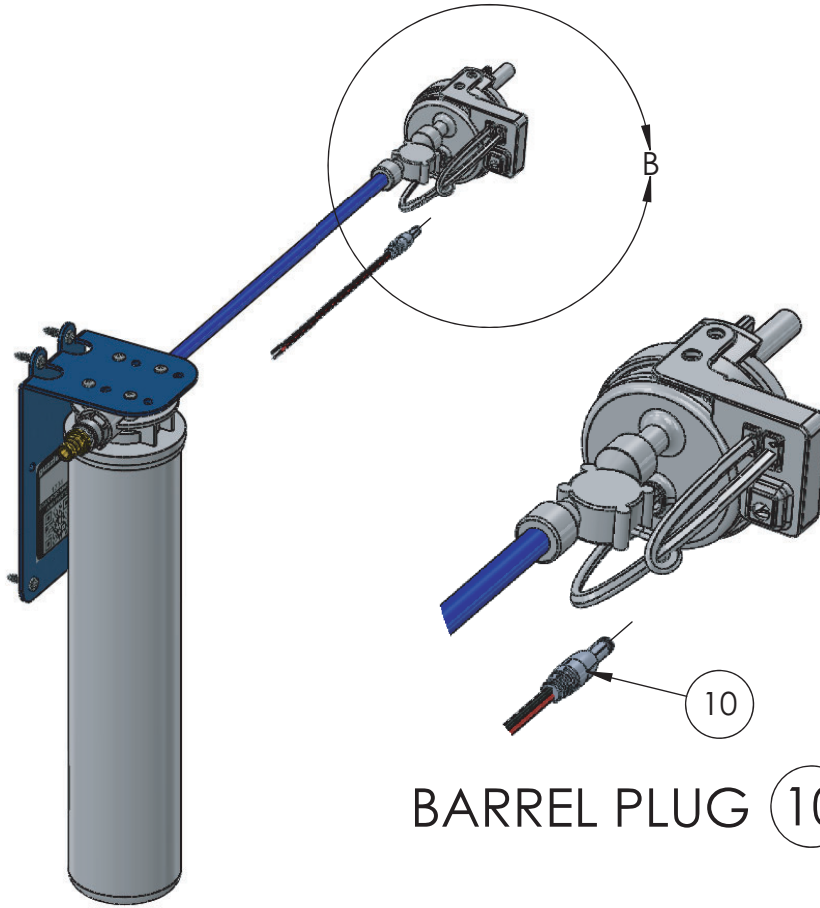

BARREL PLUG (10) INTO UV UNIT

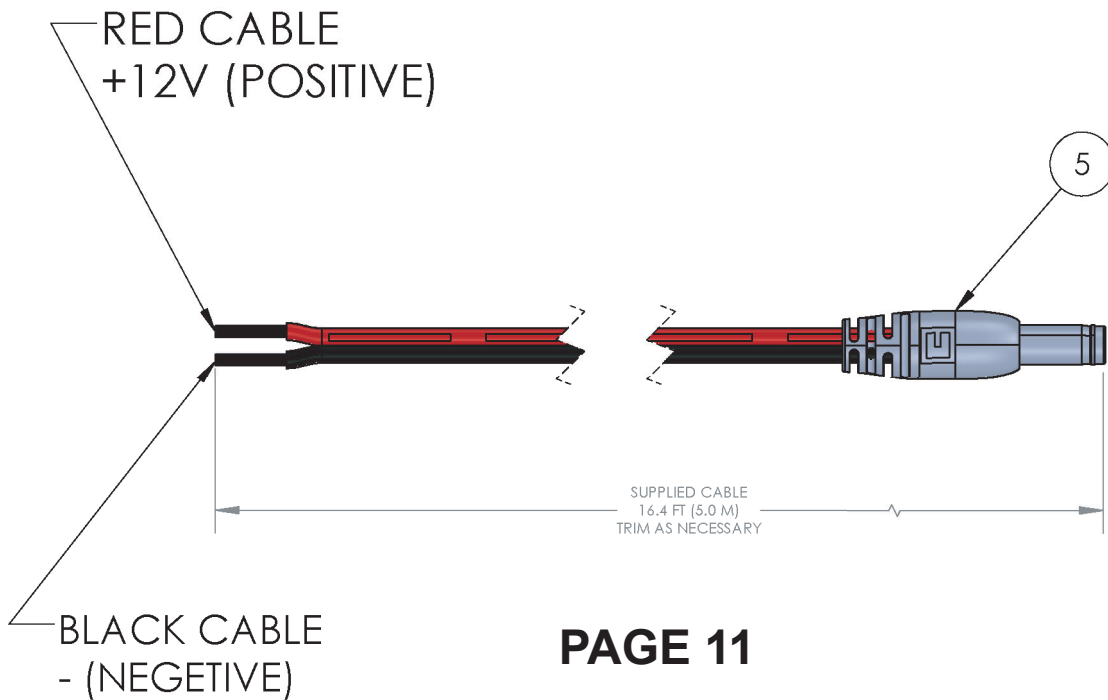

## TO DISCONNECT PUSH-TO-CONNECT FITTINGS

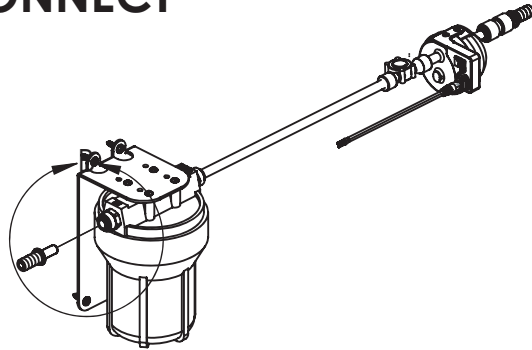

1) PRESS COLLAR  
TO RELEASE FITTING

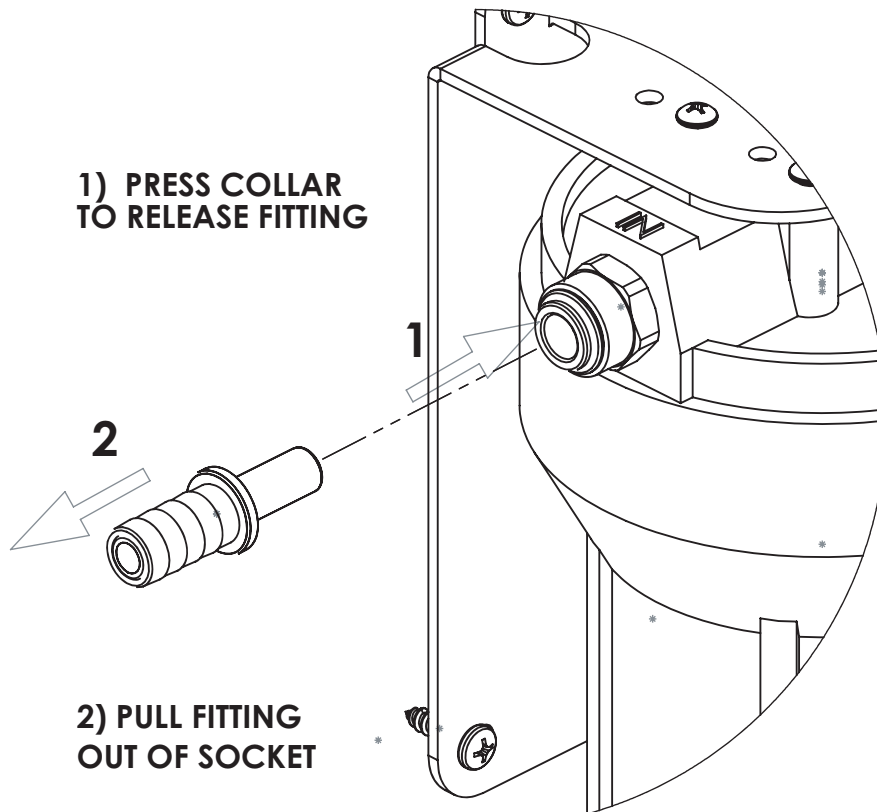

2) PULL FITTING  
OUT OF SOCKET

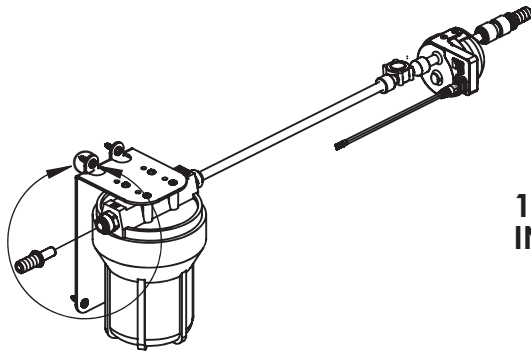

1) INSERT TUBE  
INTO SOCKET

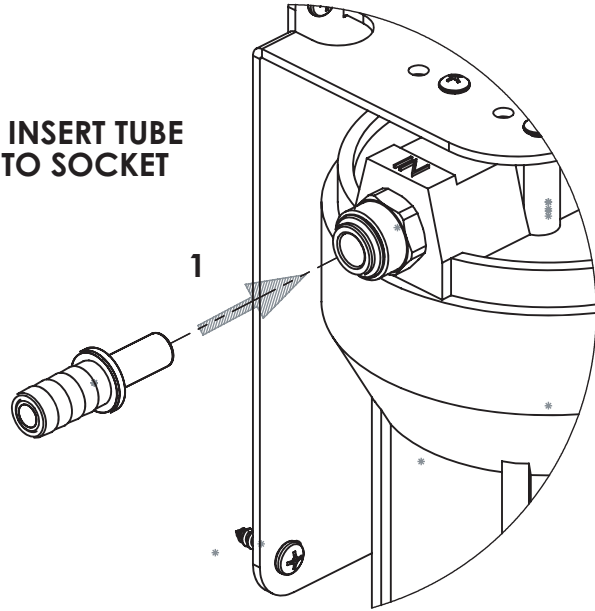

TO INSTALL  
PUSH-TO-CONNECT  
FITTINGS

2) PULL FITTING  
TO ENGAGE SEAL

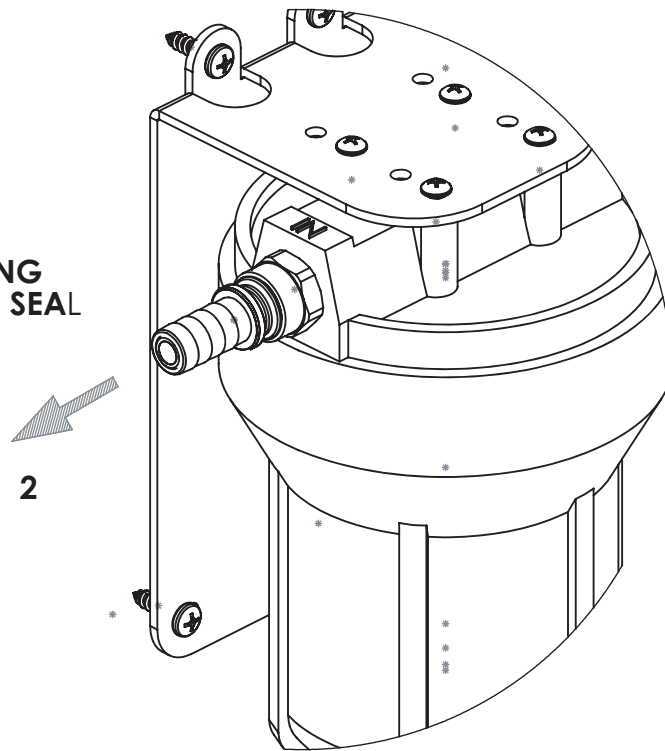

## INSTALL UV UNIT AS SHOWN TO ELIMINATE TRAPPED AIR POCKETS

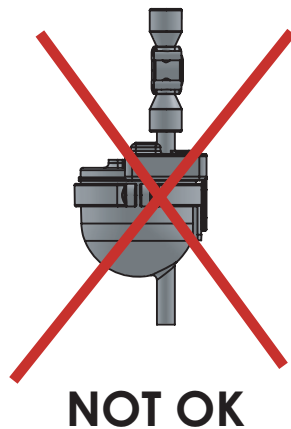
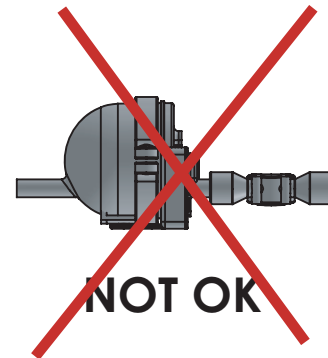
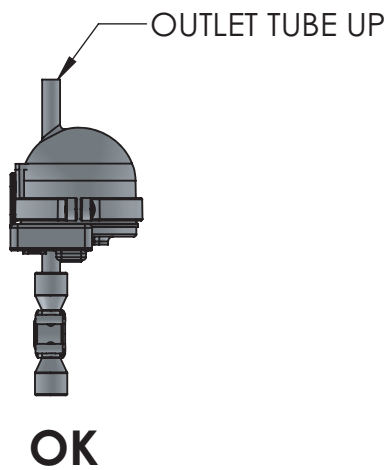
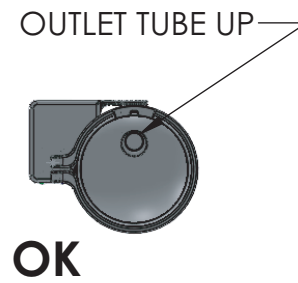
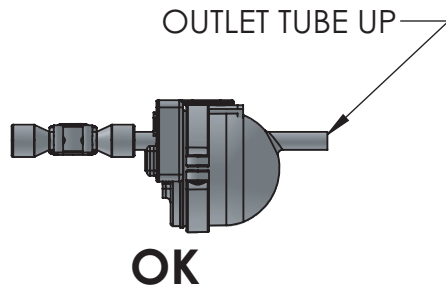

## LED STATUS CODES

BLUE	GREEN	MEANING	SOLUTION
OFF	ON	Unit is receiving adequate power; UV-C disinfection is off; water is not flowing	
ON	ON	Unit is receiving adequate power; UV-C disinfection is active; water is flowing	
BLINKING AT STARTUP	OFF	UV PulseCare Enabled	
ALTERNATE BLINKING		Thermal Error	Verify there is adequate flow through unit, no obstructions in unit, and water temperature meets specification
ON	FLASHING	LED Status Error	UV lamp replacement needed - contact Guzzle H2O



COLOR: BLUE

COLOR: GREEN



## STEALTH FLEX MAINTENANCE - CHANGING CARBON FILTER

### WHEN TO CHANGING THE CARBON BLOCK FILTER

Carbon block filter cartridge (1) should be changed after 750 gallons of use. Actual capacity may vary depending upon quality of water filtered. Reduced water flow rate through filter or at the faucet is an indication that the carbon block filter element should be changed.

### HOW TO CHANGE CARBON BLOCK FILTER

Shut off water pressure, and open faucet to drain and depressurize water line. Place a towel below filter canister to catch any water that may drain. Twist the carbon block filter canister (1) counter clockwise and pull. Install a new carbon block filter cartridge by inserting and turning clockwise to lock. Turn on water pressure, let water run. Run 5 gallons of water through system to dislodge and remove any loose carbon fines. Close faucet and check for leaks.

### LED CHAMBER MAINTENANCE FREE

The LED UV chamber has a lifespan of 10,000 hours of activated operation. It does not need to be replaced as a maintenance item.

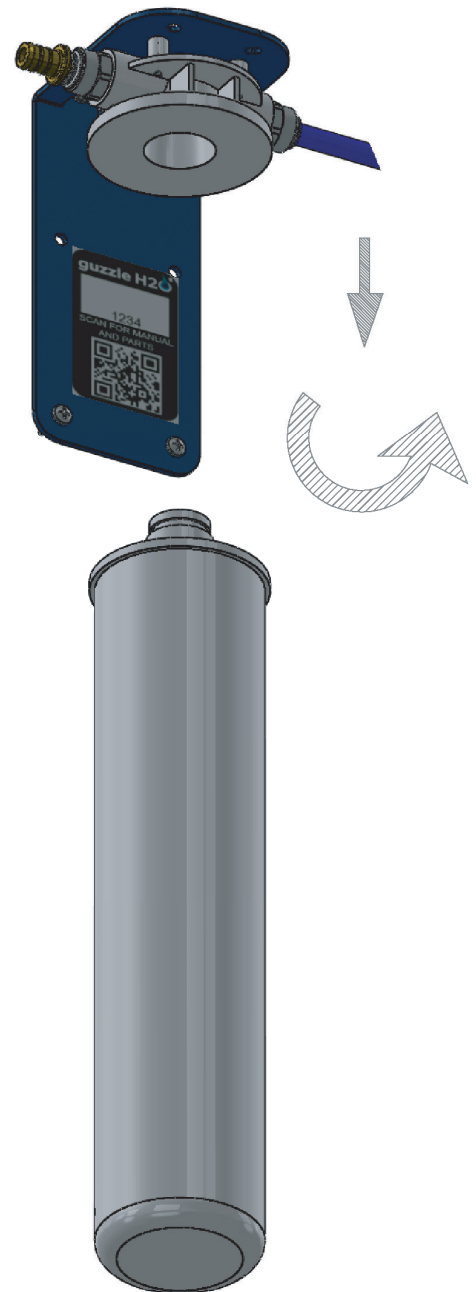

## STEALTH FLEX MAINTENANCE - WINTERIZING



# WARNING



### **FREEZING TEMPERATURES CAN DAMAGE STEALTH AND CAUSE WATER SYSTEM LEAKS AND DAMAGE**

**Temperatures below 32F (0C) can damage the Stealth Flex causing leaks and loss of performance. Follow WINTERIZATION PROCEDURES to prepare Stealth for freezing conditions.**

#### **WINTERIZATION PROCEDURES**

In below freezing temperatures, water **MUST BE REMOVED** from the Stealth Flex or damage may occur to the UV unit and carbon filter. Follow these procedures in addition to any recommendations that may come with the rest of your water system. See diagram page 18.

- 1) Remove carbon cartridge (1). Twist counterclockwise and pull out of socket.
- 2) Insert Cap (7) and turn clockwise to secure and seal .
- 3) Use air to push water out of the Stealth Flex. Open the faucet. Pump compressed air into the water system via a blowout valve and push air and water through the UV unit and out the faucet. Water should come out of open faucet. Pulse air until no more water is expelled through faucet, and water is removed from UV unit.
- 4) Close the faucet.

**ALTERNATIVELY TO THIS PROCEDURE, anti-freeze fluid may be used to protect the Stealth Flex** from freezing conditions. Remove CARBON BLOCK CARTRIDGE (1) as described on page 18 and follow manufacturer instructions for distributing food safe anti-freeze fluid throughout the system including the Stealth Flex to prevent damage from water from freezing.

## STEALTH FLEX MAINTENANCE - WINTERIZING



# WARNING



## **FREEZING TEMPERATURES CAN DAMAGE STEALTH AND CAUSE WATER SYSTEM LEAKS AND DAMAGE**

Temperatures below 32F (0C) can damage the Stealth Flex causing leaks and loss of performance. Follow **WINTERIZATION PROCEDURES** to prepare Stealth for freezing conditions.

### WINTERIZATION PROCEDURES

#### REMOVE FILTER AND INSERT CAP FOR WINTERIZING

- 1) TURN OFF WATER PRESSURE
- 2) TURN CARBON CARTRIDGE COUNTER CLOCKWISE TO UNLOCK FROM FILTER BASE
- 3) INSTALL FILTER CAP. INSERT IN SOCKET AND TURN CLOCKWISE TO LOCK IN PLACE
- 4) FOLLOW INSTRUCTIONS TO BLOWOUT WATER SYSTEM OR FILL WITH ANITFREEZE SOLUTION.

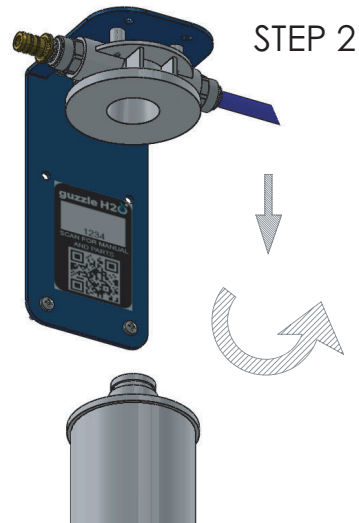

#### STEP 3

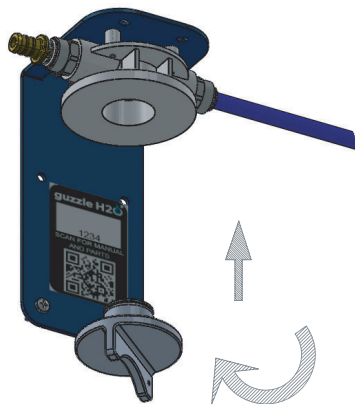

## STEALTH SYSTEM TIPS AND TROUBLE SHOOTING

- 1) Secure all hoses and cables connecting to the Stealth Flex. Loose and vibrating connections can lead to water leaks and faulty electrical connections.
- 2) After replacing carbon filter cartridge with a new filter, some visible black carbon fines may be dislodged in new carbon filter. This is normal, allow approximately 5 gallons of water to pass to remove carbon fines.
- 3) For best performance, filter and purify water as close to point of use as possible. The Stealth should be the last thing your drinking water passes through before faucet. For whole system filtration, consult Guzzle H2O.
- 4) For installation, consider ease of access, max length and minimum bend radius of piping, electrical connections when selecting installation location. Use appropriate pipe and tubing compatible with supplied barbed fittings.
- 5) Note that the UV unit may be attached with push to connect fittings directly to a faucet. This creates a very space saving installation.
- 6) The carbon filter will cause a 3-5 psi pressure drop in line pressure as it filters water. This may cause automatic pressure water pumps to cycle on and off as pressure limit is reached. This is normal. Adjust pump pressure to accommodate, or consult Guzzle H2O for higher flow options.
- 7) Stealth Flex should be installed in a protected, watertight area. It is very rugged, but not made for outdoor installation.
- 8) There are various inlet and outlet attachments that accommodate PEX tubing, and faucet connections. Consult Guzzle H2O for options for specific plumbing connections.
- 9) Periodically clean onboard water tanks by shock treating with bleach or chlorine. This will reduce buildup of contaminants. The carbon block filters will do an excellent job of removing any residual chlorine from cleaning efforts.
- 10) Label carbon filter cartridge with install date to track when it is time to replace.
- 11) A 110V power adapter is available for installations requiring connection to mains power.
- 12) Use double sided tape to hold mounting bracket to wall to secure mounting screws.
- 13) Replacement filters are available on a subscription basis from [www.guzzleh2o.com](http://www.guzzleh2o.com) for automatic re-order every 6 months.

**FOR SUPPORT OR TECHNICAL ASSISTANCE FROM GUZZLE H2O  
PLEASE EMAIL US AT [INFO@GUZZLEH2O.COM](mailto:INFO@GUZZLEH2O.COM)**

## PRODUCT SPECIFICATIONS AND CAPACITIES

**MAXIMUM FLOW RATE; TAP WATER: 2.1 GALLONS (8.0 LITRES) / MIN**

**FLOW RATES AND CAPACITIES ARE FOR IDEAL CONDITIONS. FLOW RATES AND CAPACITIES MAY BE REDUCED BY CARBON BLOCK FILTER AGE, WATER QUALITY, OR WATER PRESSURE**

**ACTIVATED CARBON BLOCK FILTER 0.5 MICRON NOMINAL**

REDUCES: NSF Particulate Class I sediment, chlorine taste and odor, VOCs, NSF 41 emerging contaminants, lead, mercury, PFAS, microplastics, turbidity, . Will not remove heavy metals or toxins

CHANGE AFTER: 750 gallons OR 6 month use, whichever comes first

**LED UV-C PURIFICATION: 99.99% REDUCTION IN PROTOZOA, BACTERIAL, AND VIRUSES**

Based on 3rd Party Testing to US EPA Ultraviolet Disinfection Guidance Manual

Tested and Certified by NSF International against NSF Standard 55 for Performance, Materials and Structural Integrity

10,000 hour lifespan

**MAXIMUM SYSTEM PRESSURE 120 PSI (8.3 Bar)**

**MINIMUM SYSTEM PRESSURE 30 PSI**

**SYSTEM TEMPERATURE MIN: 32F (0C) / MAX 113F (45C)**

**POWER DRAW ACTIVE 1 AMP**

**POWER DRAW STANDBY MODE 0.1 AMP**

**NSF LISTED AND FDA APPROVED MATERIALS**



SCAN HERE TO FIND PARTS,  
MANUALS, AND RESOURCES  
FROM GUZZLE H2O

[WWW.GUZZLEH2O.COM](http://WWW.GUZZLEH2O.COM)

**END  
OF  
MANUAL**

**GUZZLE H2O LLC    WWW.GUZZLEH2O.COM    INFO@GUZZLEH2O.COM  
363 JEWETT BLVD, WHITE SALMON, WA USA**