



Image shows Natural & Blush

### Product Description

Handmade in the UK, the ceramic Case Pendant is produced in small batches to ensure the crisp form, tactile finish and exact colour are achieved. Creating a drop pendant that works equally well as a single light source, in a row or a cluster. With its neat proportions and tactile quality, the Case Pendant is an elegant and versatile light, easily placed within any space.

**Product Type** Compact Pendant Lamp

**Materials** Earthenware Ceramic, Fabric cable

**Fittings** E27 Bulb Holder, Ceiling Rose

**Colour** Natural, Charcoal, Blush

### Cleaning Instructions

Wipe clean with a damp cloth, leave to dry naturally, do not use detergent or abrasive cleaning agents. Always turn off electricity before cleaning.

### Overall Dimensions (mm)

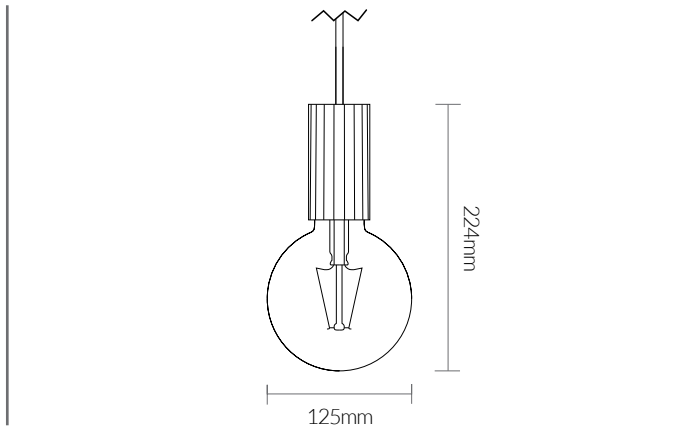

### Pendant and Cable Colours



**Bulb** 125mm E27 Globe LED (Included)

**RRP (GBP)**



**Weight** 0.5 kg



**Cable Length** 3m fabric



**Ceiling Rose** Metal Ceiling Plate



**Packaging** Heavy-weight corrugated cardboard

**Clear Globe** £65.00

240V 4W 2300K E27 Dimmable

**Frosted Globe** £90.00

240V 4W 2300K E27 Dimmable

**Oblo Porcelain** £135.00

6W CRI 95 540 Lumens Dimmable