

VITAMIN

Pitch Pendant

Product Specification Sheet

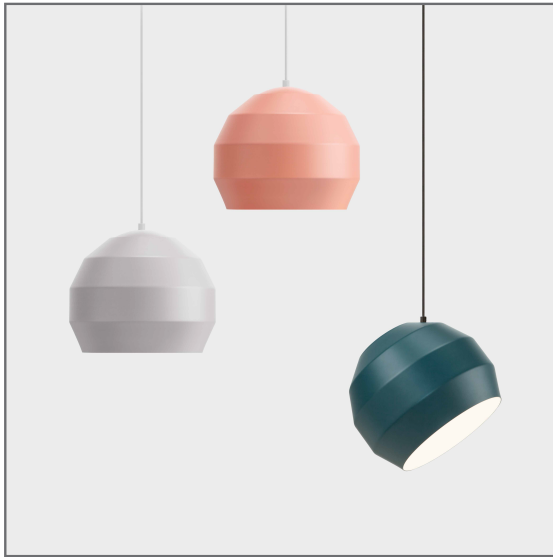

Image shows Light Grey, Coral & Blue

Product Description

Handmade in the UK, the Pitch Pendant lamp comprises a banded spun aluminium shade poised on an internal dome, the outer shade can be posed to guide light in any direction. The bands of the outer shade create varying tonal strips of colour. With an iconic silhouette when hung alone, the lines of the lamp also complement each other when hung as a cluster.

Product Type Pendant Lamp

Materials Aluminium, PVC cable

Fittings E27 Bulb Holder, Ceiling Rose

Colour Black, White, Light Grey, Dark Grey, Coral, Green, Blue, Electric Coral

Cleaning Instructions

Clean with a dry lint-free cloth. Do not use any abrasive cleaning products or polishing agents. Always turn off electricity before cleaning.

Overall Dimensions (mm)

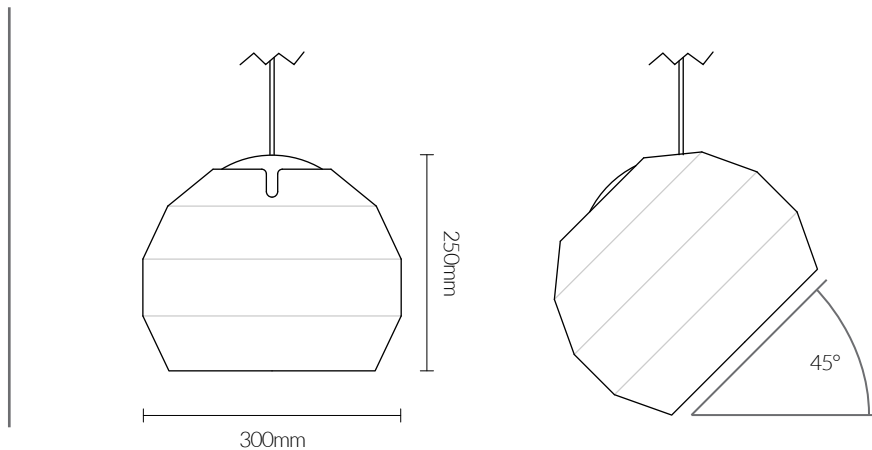

Pendant and Cable Colours



Bulb E27 LED (Not Included)

RRP (GBP)



Weight 1.2 kg



Cable Length 3m PVC



Ceiling Rose Matt White or Matt Black Cone



Packaging Heavy-weight corrugated cardboard

All colours £160.00