

VITAMIN

Knot Lamp

Product Specification Sheet



Image shows Large Knot Lamp with a Mid Blue cable & Small Knot Lamp with a Dusky Pink cable

Product Description

The Knot Lamps come in two different designs of hand blown glass shade each supported by a monkey fist knot. The lamps are versatile and can be displayed in an illuminating cluster or line, or alone creating a single ambient glow. Whichever way you choose to display them, the Knot Lamps will subtly draw attention with their enigmatic aura.

Product Type Pendant Lamp

Materials Blown Glass, Fabric cable

Fittings ES/E14 Bulb Holder, Ceiling Rose

Colour Clear Shade, selection of 12 Coloured Cables

Cleaning Instructions

Clean with a dry lint-free cloth. Do not use any abrasive cleaning products or polishing agents. Always turn off electricity before cleaning.

Overall Dimensions (mm)

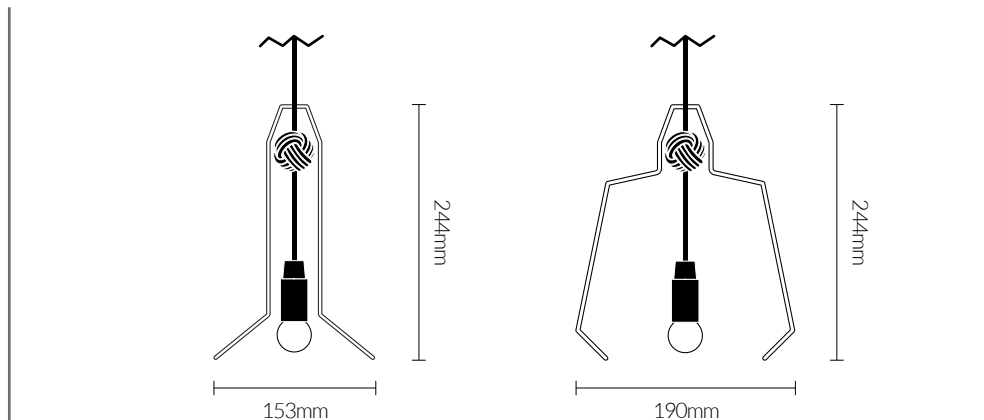

Cable Colours



Bulb ES/E14 Bulb (Not Included) - Do not exceed 30W

RRP (GBP)



Weight Large - 0.8 kg | Small - 0.4 kg

Large Knot Lamp £160.00



Cable Length 2m fabric (5m upon request)

Small Knot Lamp £130.00



Ceiling Rose Matt White Cone



Packaging Heavy-weight corrugated cardboard