

RC10 SC6.4 TEAM KIT

1:10 Scale 2WD Electric Off Road
Competition Short Course Kit



#70009 RC10SC6.4, Team Kit

1:10 Scale 2WD Electric Off Road Competition Short Course Truck Manual



CHAMPIONS *by* DESIGN

AssociatedElectrics.com

TEAM ASSOCIATED

:: Introduction

Thank you for purchasing this Team Associated product. This assembly manual contains instructions and tips for building and maintaining your new vehicle. Please take a moment to read through the manual and familiarize yourself with the steps. We are continually changing and improving our designs; therefore, actual parts may appear slightly different than the illustrations. New parts will be noted on supplementary sheets located in the appropriate parts bags. Check each bag for these sheets before you start to build. Check www.rc10.com for the latest versions of our instruction manuals.

:: RC10SC6.4 KIT Features

- New 13mm big bore threaded aluminum shocks and springs with machined shock pistons for improved bump / jump handling
- 13mm machined shock pistons, 2x1.6mm front and 2x1.8mm rear
- New front ballstud mount and top plate with angled steering system for improved steering consistency
- New 3.5mm heavy-duty ball cups and turnbuckles for maximum durability
- Updated rear suspension with wider C and D mounts from the RC10B6.4 series
- New longer 92.5mm CVA driveshafts for more rear grip
- 7.0mm blue aluminum rear clamping hexes with laser etching
- New chassis side rails with the RC10B6.4 fan mount system
- New short course truck length aluminum chassis with 22.5° kick-up to complement updated front-end geometry and with new shape to reduce chassis scrub with the track surface
- 20°, 22.5°, and 25° molded bulkheads included for a complete range of caster and kickup options 0°, +2.5°, -2.5° Bulkhead
- B6.4 adjustable height steering bellcrank and rack system for optimized bumpsteer at all ride heights and caster angles
- B6.4 -1mm kingpin offset steering and caster block set for smoother and more predictable steering through the entire wheel throw
- Aluminum RC10B6.4 ESC mounting tray with a wider footprint to fit electronics, resulting in a weight bias placed further forward
- Factory Team RC10B6.4 11g aluminum ESC tray

:: Additional

Your new SC6.4 Team Kit comes unassembled and requires the following items for completion (Refer to www.rc10.com and www.Reedypower.com for complete listings):

- RC two channel surface frequency radio system
- AA-size batteries for transmitter (#302 alkaline)
- Electronic Speed Control, ESC
- Steering servo
- 540 size electric motor
- Pinion gear (48P), size determined by type/wind of motor
- Battery charger (a peak detection charger, or LiPo compatible charger)
- 2 cell shorty LiPo battery pack
- Polycarbonate 1/10 Short course body
- Polycarbonate specific spray paint

- Cyanoacrylate glue (CA)(#1597)
- Thread locking compound (#1596)
- Tires and Inserts, Fronts and Rears
- Wheels w/12mm Hex
Black Method Wheels #71040

:: Other Helpful Items

















- Silicone Shock Fluid (Refer to www.rc10.com for complete listings):
- Body Scissors (AE Part #1737)
- FT Hex/Nut Wrenches (AE Part #1519, 1650)
- Green Slime shock lube (AE Part #1105)
- Soldering Iron
- Needle Nose Pliers
- FT Body Reamer (#1499)
- FT Ballcup Wrench (#1579)
- FT 4mm Turnbuckle Wrench (#1112)
- Hobby Knife
- Shock Pliers (#1681)
- FT Universal Tire Balancer (#1498)
- Calipers or a Precision Ruler
- Wire Cutters

Associated Electrics, Inc.
21062 Bake Parkway.
Lake Forest, CA 92630



:: Hardware - 1:1 Scale View









Button Head (bhcs)

	2x4mm (31510)
	2.5x6mm (31520)
	2.5x8mm (31521)
	2.5x10mm (31522)
	3x4mm (91158)
	3x5mm (31530)
	3x6mm (31531)
	3x8mm (31532)
	3x10mm (25211)
	3x12mm (89202)
	3x14mm (25187)
	3x16mm (89203)
	3x18mm (2308)
	3x20mm (25188)
	3x22mm (25189)
	3x24mm (89204)
	3x30mm (91478)





Shims and Washers

	5.5x0.5mm (31381)
	5.5x1.0mm (31382)
	5.5x2.0mm (31383)
	2.6x6mm Washer (89278)
	3x8mm Washer (89218)





Flat Head (fhcs)

	2x3mm (91749)
	2.5x8mm (31448)
	3x8mm (25201)
	3x10mm (25202)
	3x12mm (25203)
	3x14mm (89208)
	3x16mm (25204)
	3x18mm (89209)





Set Screws

	3x2.5mm (31500)
	3x3mm (25225)
	3x5mm (89219)
	3x10mm (4671)
	3x20mm (91737)





Socket Head (shcs)

	1.6 x 5mm (91611)
	2.5 x 14mm (71032)
	3 x 18mm (25191)
	3 x 6mm (41089)
	3 x 22mm (41095)









Diff Balls

	3/32 Carbide Diff Balls (6581) (kit)
	3/32 Ceramic Diff Balls (6584) (FT Option)
	Thrust Washer (91990)
	Caged Thrust Washer (91990)



Ball Bearings

	4x7x2.5mm (31732)
	5x8x2.5mm (8680)
	5x10x4mm (91560)
	5x12x4mm (91567)
	10x15x4mm (91563)

Ballstuds

	Silver 5mm long (31283)
	Silver 8mm long (31284)
	HD 6mm (91047)
	Ti HD 6mm (91751)
	HD 8mm (91048)
	Ti HD 8mm (91752)
	HD 10mm (91049)
	Ti HD 10mm (91753)

Nuts (lock/plain)

	M3 Plain Nut (91477)
	M3 Alum. Locknut, Blue (31550)
	M3 Locknut, Black (25215)
	M3 Locknut w/Flange (25612)
	FT 3mm Locknuts, Blue(25392)
	M4 Nuts: Serrated Steel (Silver)(91826)
	FT Alum. Locknut (Blue) (25391)
	Serrated Steel (Black) (91738)
	Serrated Steel LP (Black) (91150)

Notes:

:: Table of Contents

1..... Cover	14.....Bag 7: Rear Hubs
2..... Introduction	14 - 15.....Bag 8: Turnbuckles
3.....1:1 Hardware "Fold Out"	16 - 18.....Bag 9: Shocks
4..... Table of Contents	19 - 22.....Bag 10: Battery Strap, Body, and Wheels
5.....Bag 1: Steering	23.....Notes
5 - 8.....Bag 2: Front Suspension	24 - 25..... Tuning Tips
8 - 9.....Bag 3: Caster Blocks	26..... Back Cover
9 - 10.....Bag 4: Rear Suspension	
10 - 11.....Bag 5: Ball Diff	
11 - 13.....Bag 6: Gearbox	

:: Notes



This symbol indicates a special note or instruction in the manual.



This symbol indicates a Racers Tip.



There is a 1:1 hardware foldout page in the front of the manual. To check the size of a part, line up your hardware with the correct drawing until you find the exact size. Each part in the foldout has a number assigned to it for ordering replacement parts.

**Associated Electrics, Inc.
21062 Bake Parkway
Lake Forest, CA 92630**

ae
ASSOCIATED ELECTRICS
SINCE 1985

**Customer Service
Tel: 949.544.7500
Fax: 949.544.7501**

:: Bag 1 - Step 1

! Note orientation of steering rack.

31732 X4
4 x 7 x 2.5 Ball Bearing

91973
Steering Bellcrank (Right)

31283
5mm Ball Stud, Long

91973
Steering Bellcrank (Left)

91973
Steering Rack

91048
Heavy-duty Ballstud, 8mm

31382 X2
FT Ballstud Washer, Aluminum (1mm)

89202 X2
M3 x 12mm BHCS

91974 X2
Steering Hat Bushing

:: Bag 1 - Step 2

25191 X2
M3 x 18mm SHCS

91974 X2
Steering Hat Bushing, Low

31732 X4
4 x 7 x 2.5 Ball Bearing

91049 X2
Heavy-duty Ballstud, 10mm

31382 X2
FT Ballstud Washer, Aluminum (1mm)

71182
Front Ball Stud Mount

Steering	Bulkhead	Caster Insert	Chassis	Total Insert
High	2.5°	0°	22.5°	25°
Low	2.5°	2.5°	22.5°	27.5°
Low	2.5°	5°	22.5°	30°
High	0°	0°	22.5°	22.5°
High	0°	2.5°	22.5°	25°
Low	0°	5°	22.5°	27.5°
High	-2.5°	0°	22.5°	20°
High	-2.5°	2.5°	22.5°	22.5°
High	-2.5°	5°	22.5°	25°

! (Low position) Bellcranks down, hat side on top

! (High position) Bellcranks up, hat side on bottom

! Ballstud in Outer Hole

:: Bag 2 - Step 1

71175
SC6.4 Chassis

91979
Bulkhead (use +2.5°)

89208 X2
M3 x 14mm FHCS

! Note: Check the screw length as both 14mm and 16mm are in the screw bag. Use the shorter of the two screws!

! There are two bulkheads included in the kit (0°, 2.5°). 2.5° is the standard used. The arrows on the 2.5° bulkhead should point forward for the desired setting.

ZERO
0

+2.5°
-2.5°

:: Bag 2 - Step 2

91976
B6.4 FT Alum.
Chassis Weight,
11g

91734
Battery
Foam, B6



NOTE:
Only install side
battery foam
if battery can
move side to
side.

71176
Side Rails
(L & R)

91988
Battery
Foam, B6.4

25202
M3 x 10mm
FHCS

25201
M3 x 8mm
FHCS

91749
M2 x 3mm
FHCS

#1596
thread lock

:: Bag 2 - Step 3



Do not discard these highlighted
parts! You will install them in Step 6
(bagged separately).

31500
M3 x 2.5mm
Set Screw

71128
Anti-Roll Bar,
(1.3mm)

91821
Anti-Roll
Bar Collar



Do not overtighten
#31500 - M3 x 2.5mm set screw.
You could bend the bar!

:: Bag 2 - Step 4

91997
Steering
Link, B6.4

31382
FT Ballstud
Washer, Aluminum
(1mm)

Align the servo horn 90 degrees.
Use sub trim after build to
center steering.

Servo not
included!

4671
M3x10mm
Set Screw

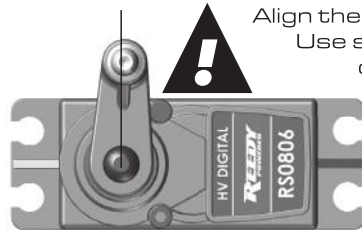

31284
8mm Ball
Stud, Long

31531
M3 x 6mm
BHCS

1364
1366
91728
Servo
Horn

91728
Servo Horn
Ring



Tighten the
steering link ball
cups all the way
until snug.

23T: Sanwa/ KO/ JR / Spektrum
24T: Hitec
25T: Reedy/ Futaba/ Savox/ ProTek / MKS

:: Bag 2 - Step 5

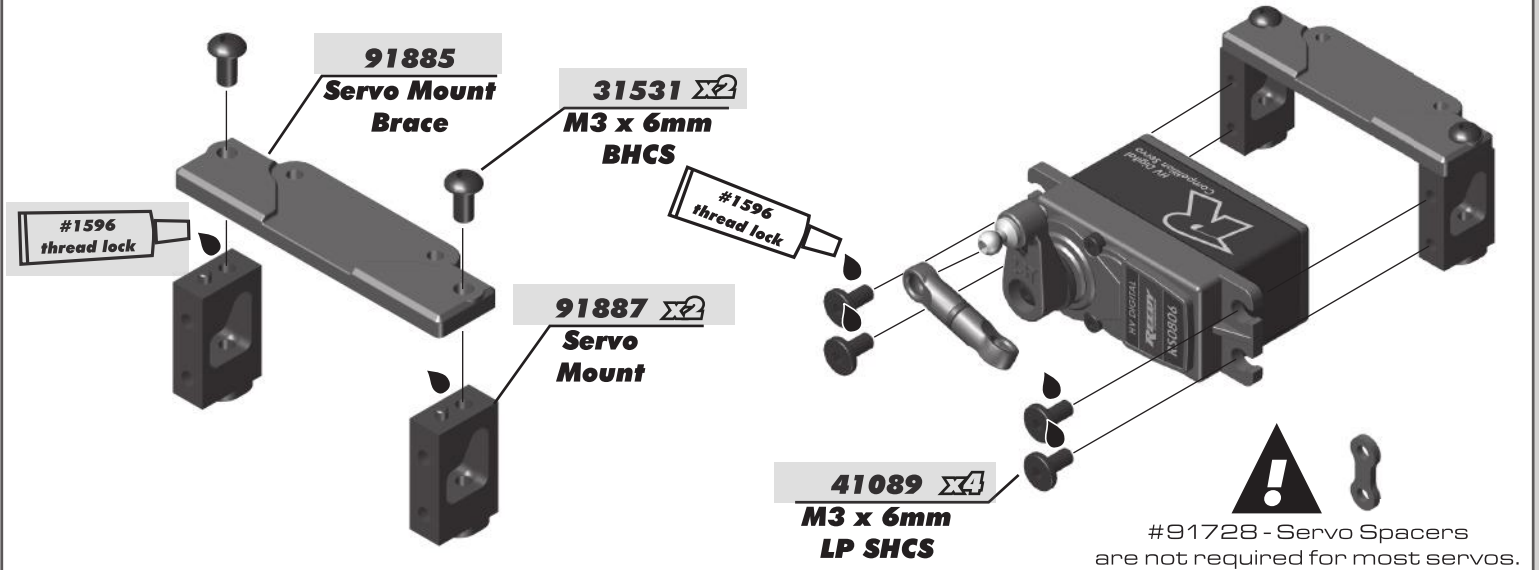

:: Bag 2 - Step 6

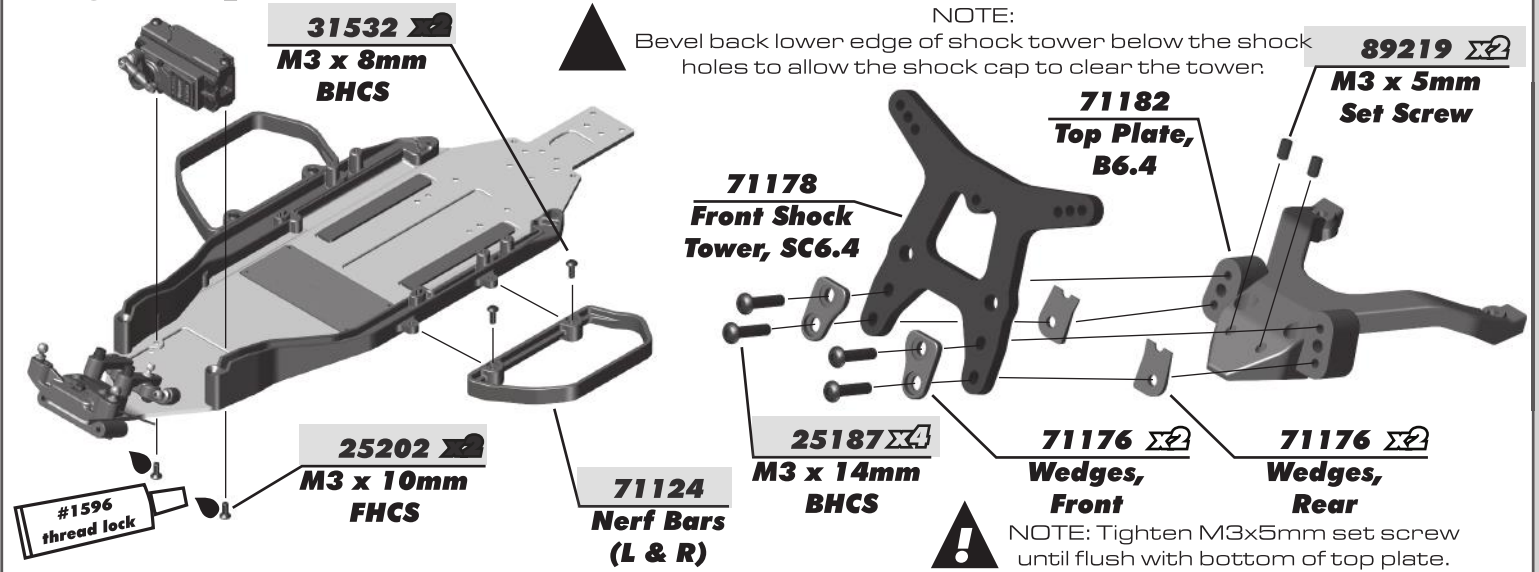

:: Bag 2 - Step 7

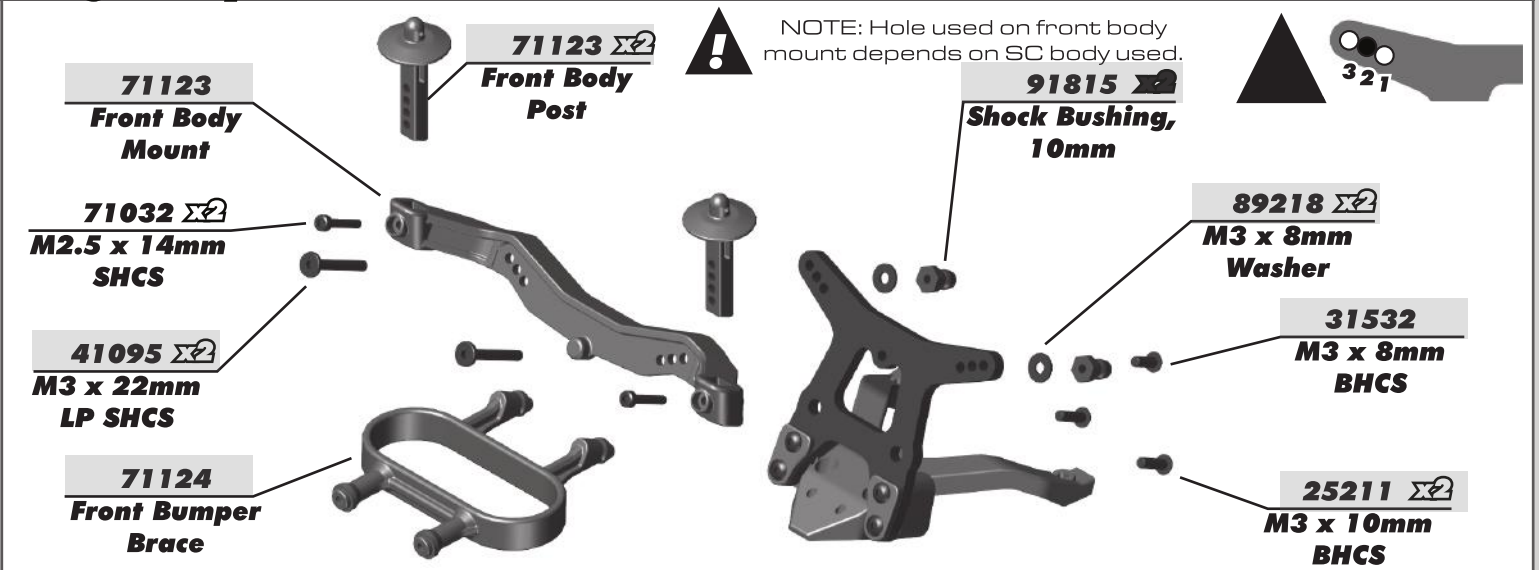

:: Bag 2 - Step 8



NOTE: Tighten M3x5mm set screw until they touch the front swaybar.

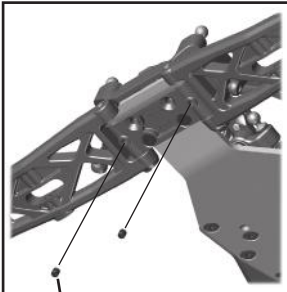
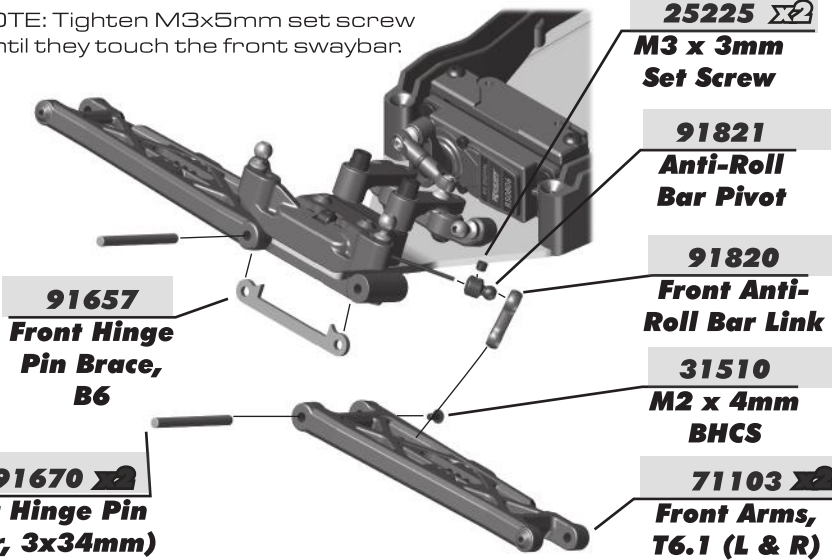

25225
M3 x 3mm
Set Screw



The front hinge pin brace has a sharp edged side, and a rounded edge side. Mount the sharp edge side towards the bulkhead.

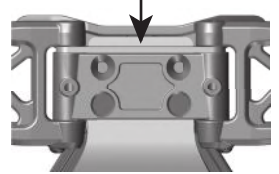

:: Bag 2 - Step 9



Install bulkhead screws, then flex up to install front screws!

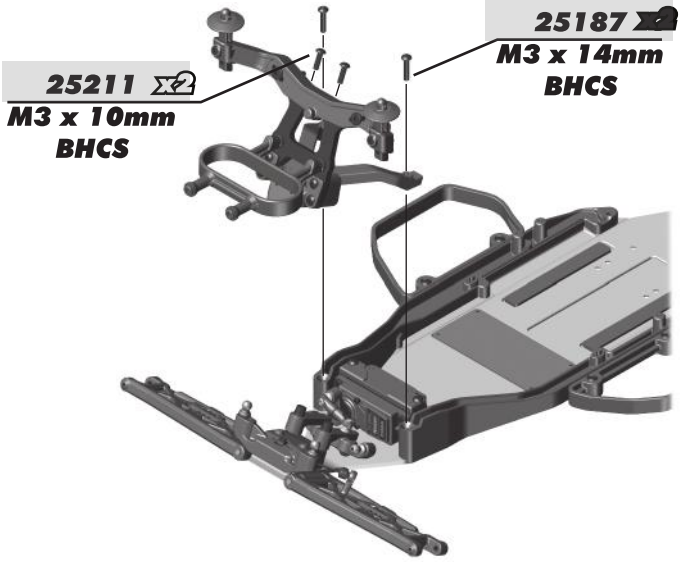

71124
Front
Bumper

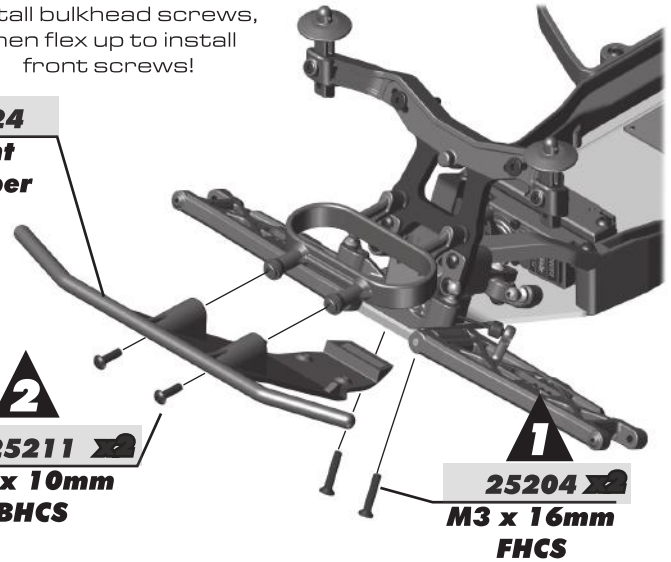

2
25211
M3 x 10mm
BHCS

1
25204
M3 x 16mm
FHCS

:: Bag 3 - Step 1

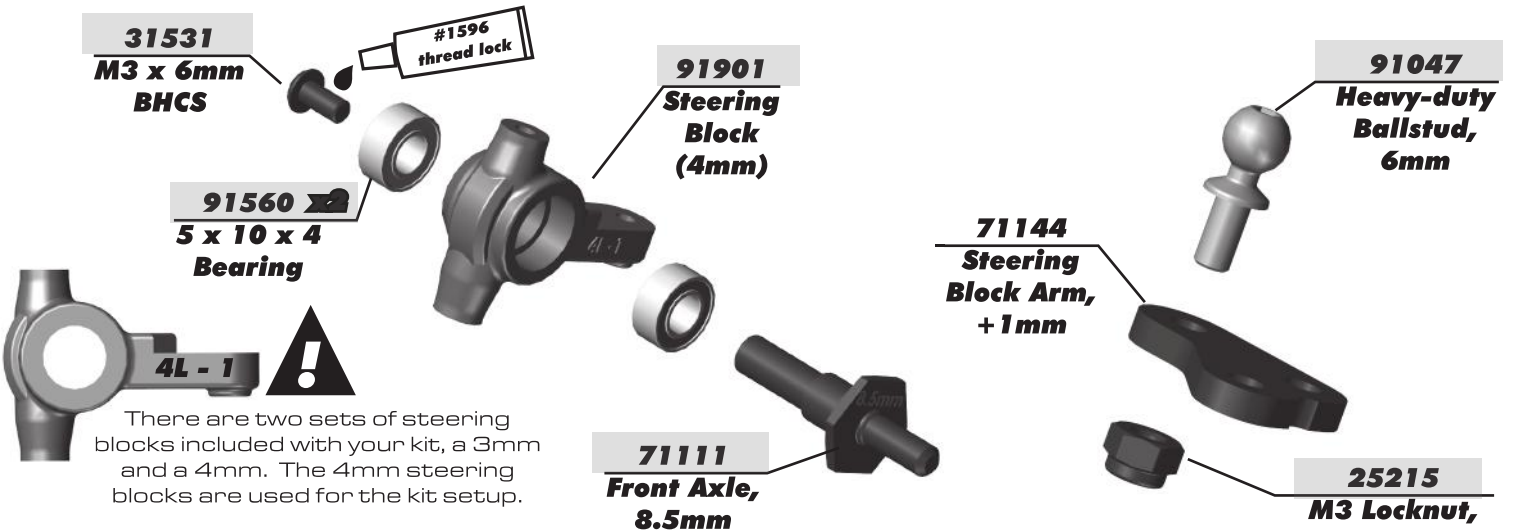

There are two sets of steering blocks included with your kit, a 3mm and a 4mm. The 4mm steering blocks are used for the kit setup.

Build 2 (1 left, 1 right)

:: Bag 3 - Step 2

Use shorter screw in front!

31531
M3 x 6mm
BHCS

31532
M3 x 8mm
BHCS

91049
Heavy-duty
Ballstud,
10mm

91901
Caster
Block

25215
M3 Locknut,
black

31520
M2.5 x 6mm
BHCS
(in bag 2)

91901
Caster
Block Insert
(+2.5°)

You can install the kit included #31520 screw to use as a steering stop setting.

You can install an optional #4670 set screw to better hold the caster block inserts and hinge pin.

There are three caster block inserts included [0°, +/- 2.5°, +/- 5°]. +2.5° is the standard insert used.
Tab up = positive caster
Tab down = negative caster

Build 2 (1 left, 1 right)

:: Bag 3 - Step 3

25187
M3 x 14mm
BHCS

91676 $\Sigma 2$
Caster Hat
Bushing
Top: 2mm
Bottom: 1mm

91776
Caster Block
Spacer

91670
Front Hinge Pin
(Outer, 3x26mm)

31510
M2 x 4mm
BHCS

89202
M3 x 12mm
BHCS

#91670 - Hinge Pin will be tight in the caster blocks, but should rotate freely in the front arms.

Build 2 (1 left, 1 right)

Build 2 (1 left, 1 right)

:: Bag 4 - Step 1

Arm Mount C: 1° Out

91882
Aluminum
Arm Mount, C

92014 $\Sigma 2$
Arm Mount
Inserts
(1°)

See next step for pill chart tips

#1596
thread lock

31541 $\Sigma 2$
M3 x 6mm
FHCS

In - Out

Mid In - Mid Out

71105
Rear Arm
Insert (Mid)

71105
Rear Arms
(L & R)

91737
M3 x 20mm
Set Screw

11mm

Build 2 (1 left, 1 right)

:: Bag 4 - Step 2

**Arm Mount D:
1° Out**



92014
**Arm Mount
Inserts (1°)**

91883
**Aluminum
Arm Mount, D**

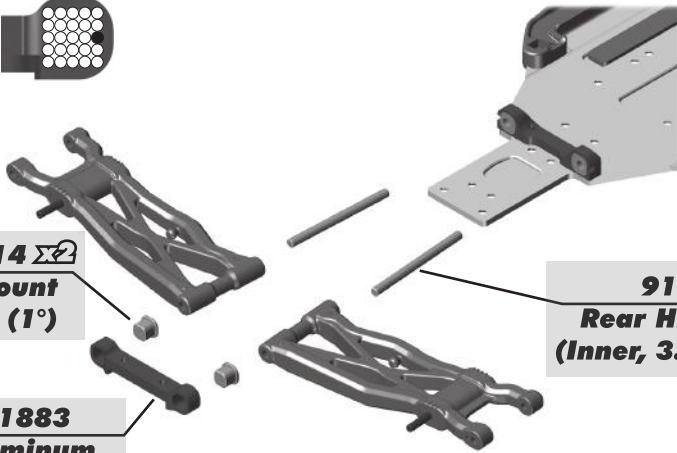

91670
**Rear Hinge Pin
(Inner, 3.5x48mm)**



The (#91882) C and (#91883) D aluminum arm mounts allow for a large amount of setup combinations when using the (#92014) 0.5° and 1° arm mount inserts.

For a complete list of pill setup combinations, see page 24, or visit our website by using the link below.

<http://bit.ly/B6PillChart>

	Toe-In	Anti-Squat
Arm Mount C: 1° Out 	3° Kit Setup	1° Kit Setup
Arm Mount D: 1° Out 		

:: Bag 5 - Step 1

#6591
diff lube

6581
**3/32 Carbide
Diff Balls**

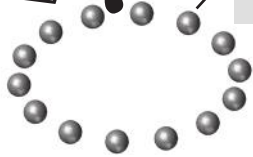

Build Tip:

The bottom side of the gear has 3 injection dots. This side faced down will keep the diff balls from falling thru the holes



91419
**Diff Gear,
52T**

7666
**Diff Drive
Ring**



#6591
diff lube



91701
**Ball Diff
Outdrive**

7666
**Diff Drive
Ring**



#6591
diff lube



91701
**Ball Diff
Outdrive**

:: Bag 5 - Step 2

#6588
black grease

91990
**Thrust
Washer**



91990
**Caged
Thrust
Bearing**



6573
**Diff Thrust
Bolt**



8680
**5 x 8 x 2.5mm,
Bearing**



Build Tip:

Install the first washer (groove up), add grease #6588. Install the caged thrust washer. Add grease on top of the balls, then install the 2nd washer (grooves down).



8680
**5 x 8 x 2.5mm,
Bearing**



Build Tip:

Do this entire step with the diff screw on the end of your wrench for better control.

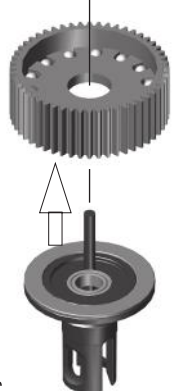

:: Bag 5 - Step 3



6575
Locking
T-nut

6582
Diff
thrust
spring

6575
Diff
cover

As you tighten the diff bolt, you will notice the T-nut ears moving closer to the bottom of the outdrive slot. This compresses the spring behind the T-nut. The spring should be completely compressed at the time the T-nut reaches the end of the slot. Caution! Pay close attention to the feeling when the spring is completely compressed. Do not overtighten the bolt. When you feel the spring completely compressed, loosen the diff bolt 1/8 of a turn. Your diff should now operate smoothly but with resistance as the outdrives move in opposite directions. After you have driven the car once, re-check the diff setting.



:: Optional Rear Anti-Roll Bar Build - NOT INCLUDED

NOT INCLUDED

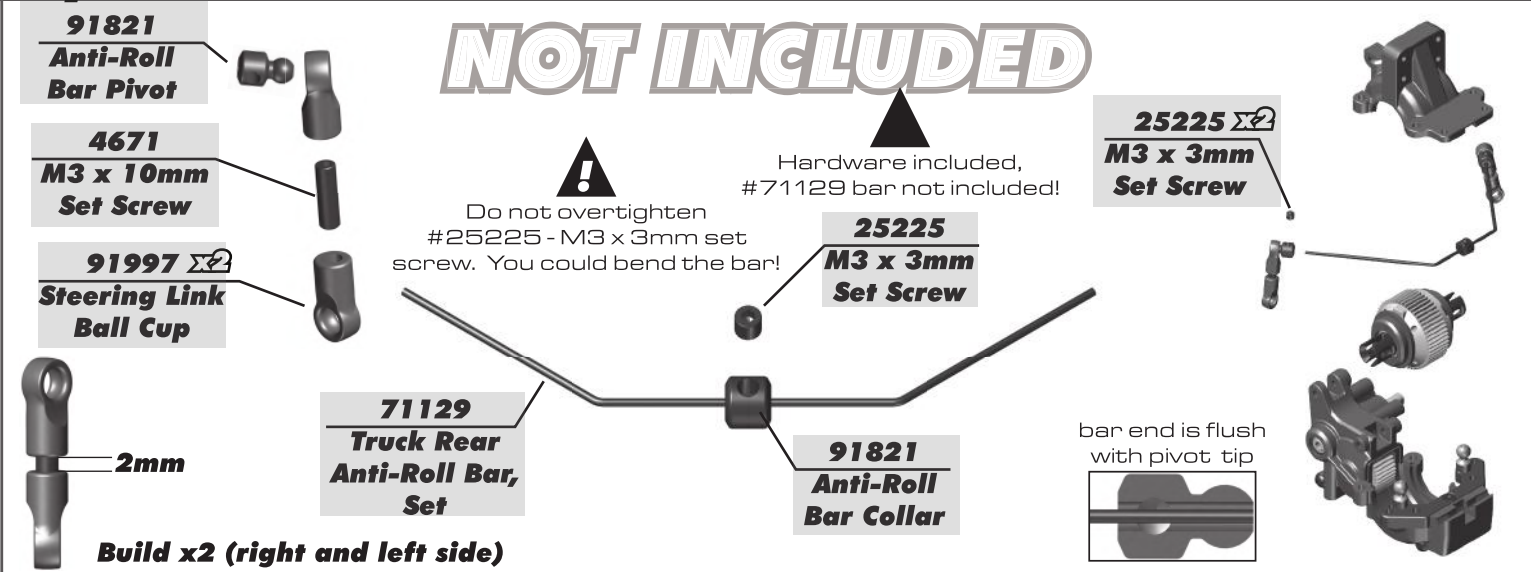

91821
Anti-Roll
Bar Pivot

4671
M3 x 10mm
Set Screw

91997
Steering Link
Ball Cup

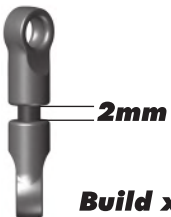

Build x2 (right and left side)

!
Do not overtighten
#25225 - M3 x 3mm set
screw. You could bend the bar!

Hardware included,
#71129 bar not included!

25225
M3 x 3mm
Set Screw

71129
Truck Rear
Anti-Roll Bar,
Set

91821
Anti-Roll
Bar Collar

25225
M3 x 3mm
Set Screw

bar end is flush
with pivot tip

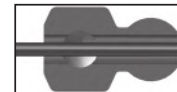

:: Bag 6 - Step 1

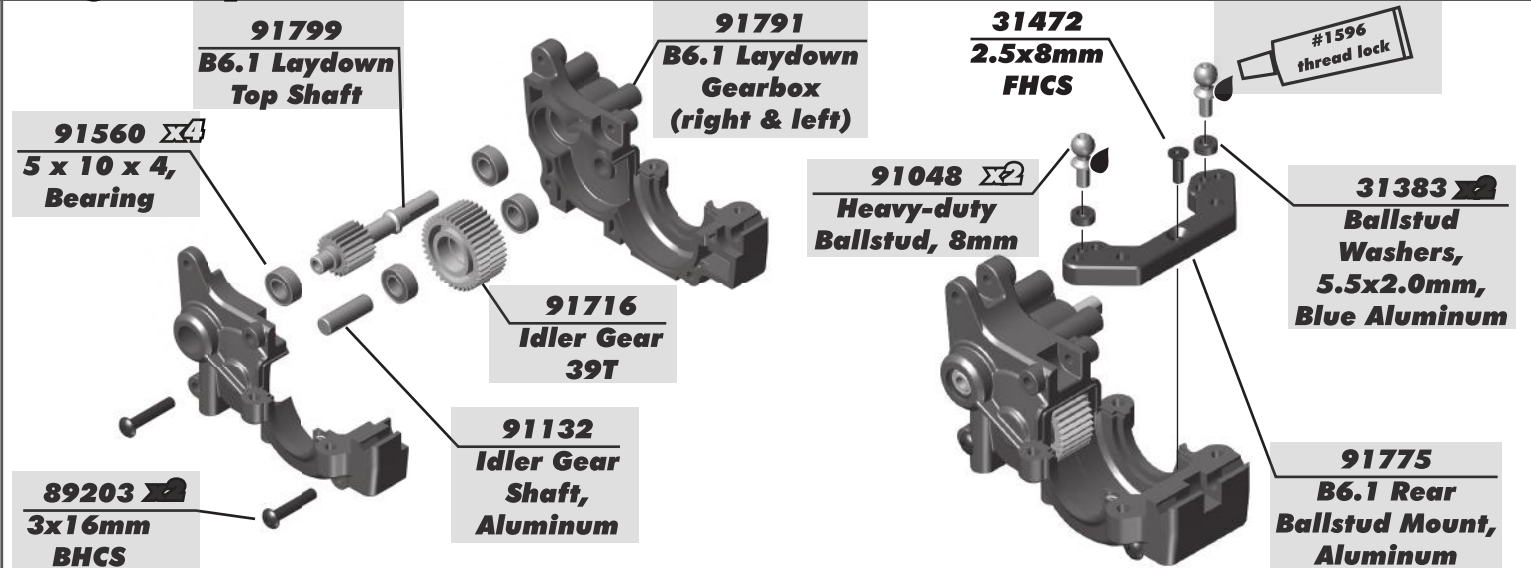

91799
B6.1 Laydown
Top Shaft

91560
5 x 10 x 4,
Bearing

89203
3x16mm
BHCS

91791
B6.1 Laydown
Gearbox
(right & left)

91716
Idler Gear
39T

91132
Idler Gear
Shaft,
Aluminum

31472
2.5x8mm
FHCS

91048
Heavy-duty
Ballstud, 8mm

#1596
thread lock

31383
Ballstud
Washers,
5.5x2.0mm,
Blue Aluminum

91775
B6.1 Rear
Ballstud Mount,
Aluminum

:: Bag 6 - Step 2

Diff Height	
	3 Kit Setup
	2
	1
	0

▲ Add a drop of Diff Lube [#6591] to the teeth of the diff gear, idler gear, and top shaft.

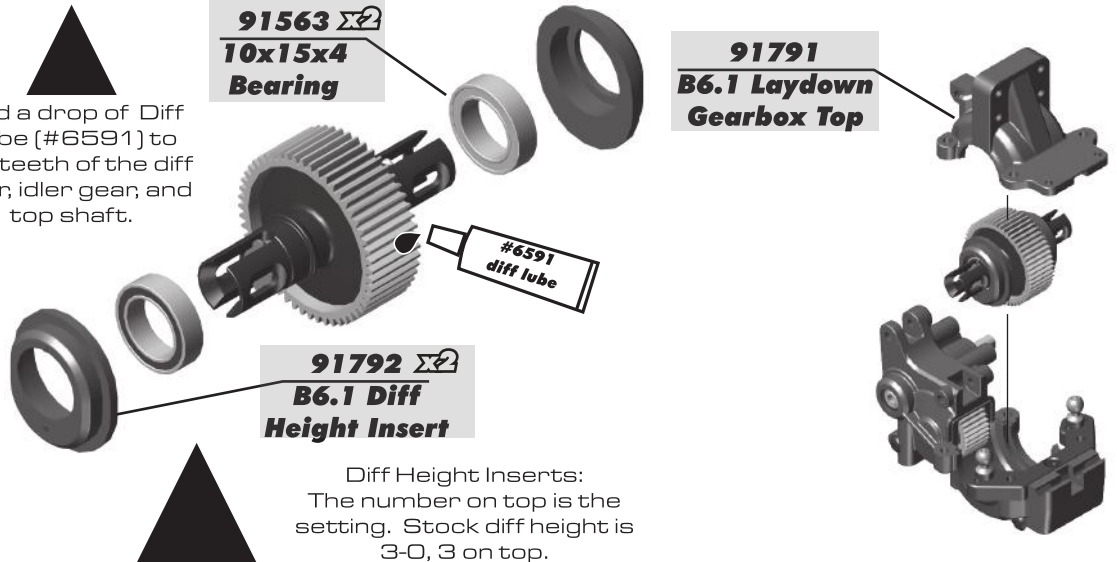

Diff Height Inserts:
The number on top is the setting. Stock diff height is 3-0, 3 on top.

:: Bag 6 - Step 3

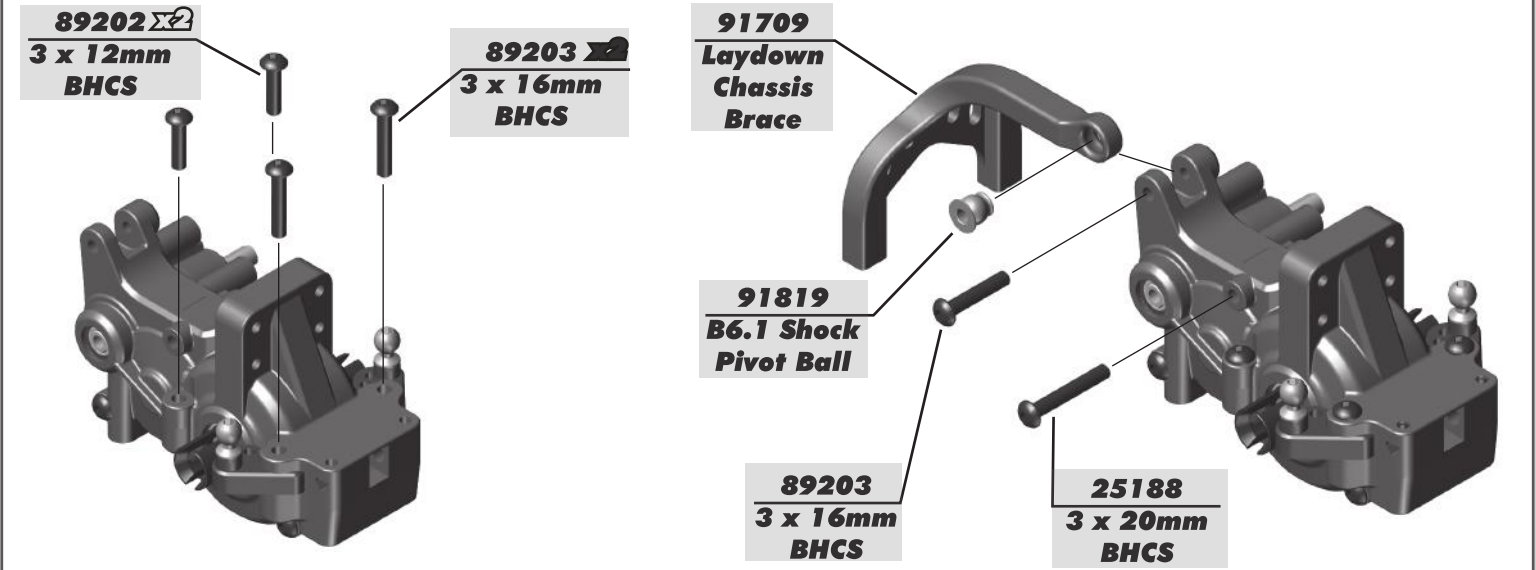

:: Bag 6 - Step 4

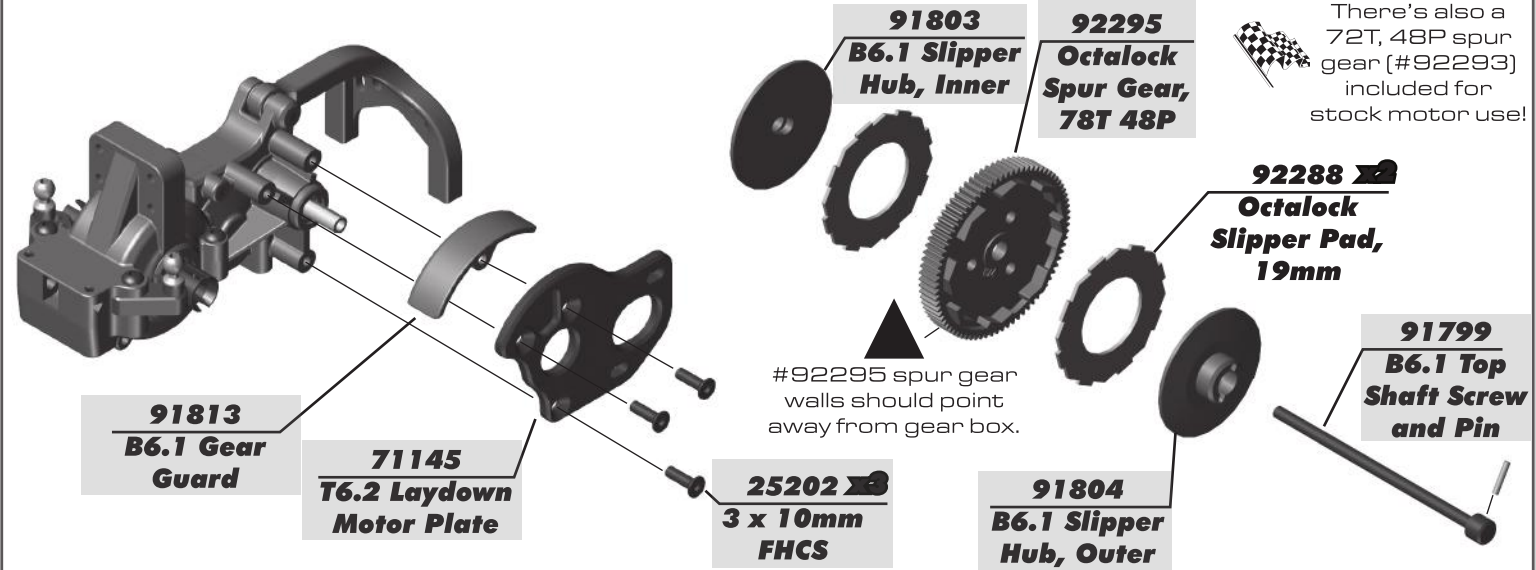

There's also a 72T, 48P spur gear [#92293] included for stock motor use!

#92295 spur gear walls should point away from gear box.

:: Bag 6 - Step 5

25612
M3 Locknut,
Flanged

91801
Slipper Spring
Adapter, Outer

91801
Slipper Spring
Adapter, Inner

91801
B6.1 Slipper
Spring

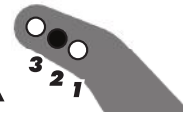

89202
M3 x 12mm
BHCS

71148
Rear Shock
Tower, SC6.2

92159
B74 Shock
Bushing,
10mm

41095
M3 x 22mm
LP SHCS

See page 20 for gear mesh, and slipper clutch setting instructions!

Set nut flush with top shaft.

:: Bag 6 - Step 6



NOTE: Hole used on rear body mount depends on SC body used.

71032
M2.5 x 14mm
SHCS

25215
M3 Locknut

71125
Rear Lower
Bumper Brace

25211
M3 x 10mm
BHCS

71123
Rear Body
Post

71123
Rear Body
Mount

71125
Rear Skid
Plate

71125
Rear Upper
Bumper Brace

71037
M3 x 45mm
BHCS

:: Bag 6 - Step 7

25187
M3 x 14mm
BHCS

25187
M3 x 14mm
BHCS

71125
Rear Bumper

25204
M3 x 16mm
FHCS

25202
M3 x 10mm
FHCS

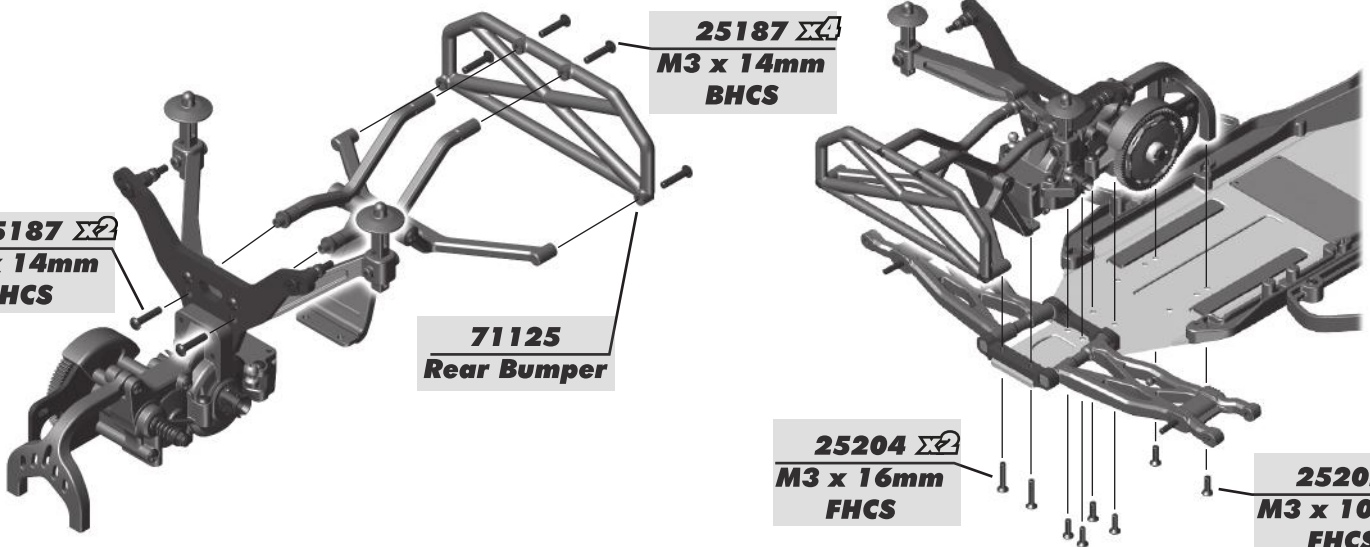

:: Bag 7 - Step 1

91047
Heavy-duty Ballstud, 6mm

#1596
thread lock

31383 $\Sigma 3$
Ballstud Washers, 5.5x2.0mm, blue

92267
Rear Hub

92180
Rear Hub Link Mounts

#1596
thread lock

92179
Rear Hub Insert

89202 $\Sigma 2$
M3 x 12mm BHCS

Build x2 (right and left side)

Rear Axle Height			
↑3	0↓		3↑ +3mm
↑2	1↓		2↑ +2mm
↓2	1↑		1↑ +1mm
↓ε	0↑		0↑ +0mm Kit Setup

:: Bag 7 - Step 2

91438
CVA Coupler

#6588
black grease

71155
CVA Bone, 92.5mm

92207
CVA Axle, 66mm

91438
CVA Pin

91563
10 x 15 x 4 Bearing

91567
5 x 12 x 4 Bearing

91436
CVA Wheel Hex Pin

91610
Clamping Wheel Hex, 7mm Offset (rear)

91611
M1.6 x 5mm SHCS

Do not overtighten the 1.6 x 5mm SHCS into the Clamping wheel hex.

Build x2 (right and left side)

:: Bag 7 - Step 3

92188
Rear Hub Hinge Pin

Hinge Pin will be tight in the rear hub, but should rotate freely in the rear arms.

92179 $\Sigma 2$
Rear Hub Spacer

31510
M2 x 4mm BHCS

Build x2 (right and left side)

:: Bag 8 - Step 1

It is important that the turnbuckle eyelets move freely once snapped on to the ballstud. If the fit is too tight, the car handling will be inconsistent. To check, grab turnbuckle eyelet with fingers and rotate the cup. If there is resistance, lightly squeeze ball cup with needle nose pliers as shown and test again. It is important that the ball cup be snapped onto the ballstud before squeezing with needle nose pliers. Be sure to check and adjust the fit for each ball cup that is installed.

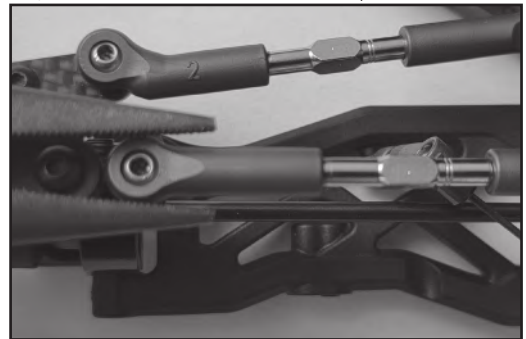

:: Bag 8 - Step 2

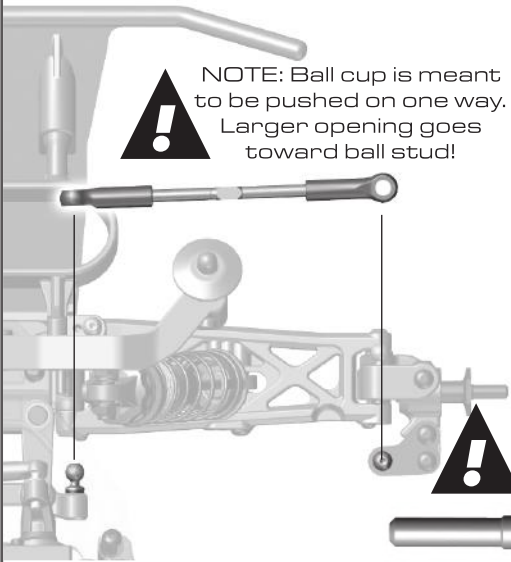

Racers Tip:

Use black grease (#6588) on the threads of the turnbuckles for easier ball cup installation!

Orient the notch to the left throughout the car. It indicates which end has the left hand threads!

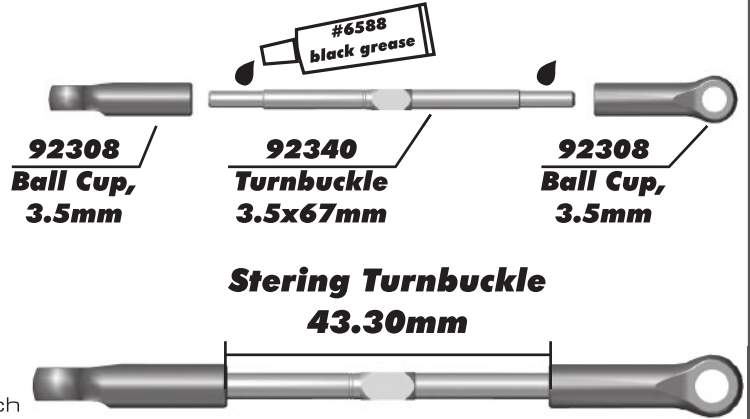

Steering Turnbuckle 43.30mm



Build x2 (right and left side)

:: Bag 8 - Step 3

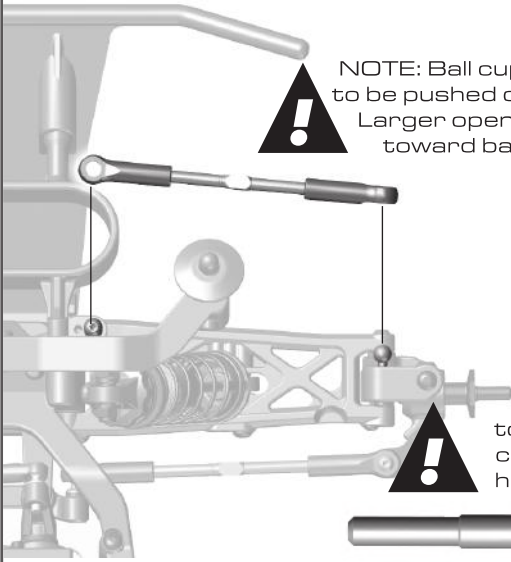

Orient the notch to the left throughout the car. It indicates which end has the left hand threads!

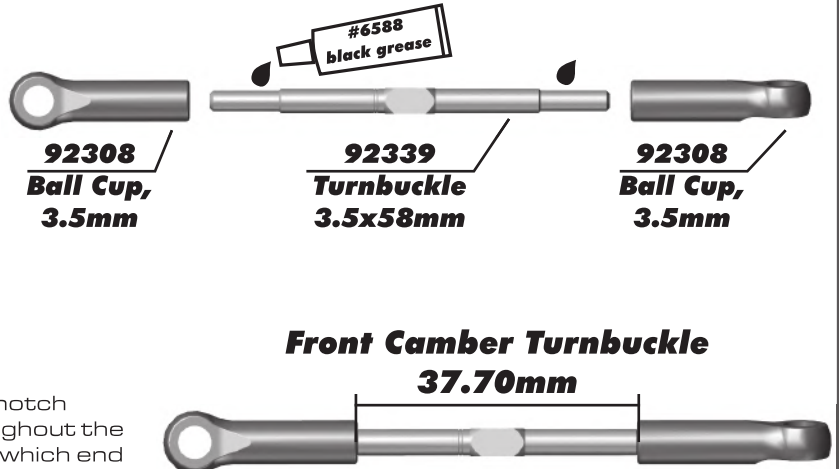

Front Camber Turnbuckle 37.70mm



Build x2 (right and left side)

:: Bag 8 - Step 4

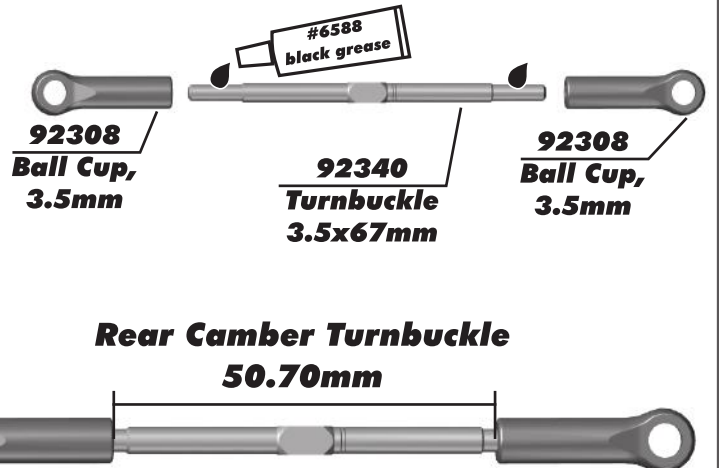
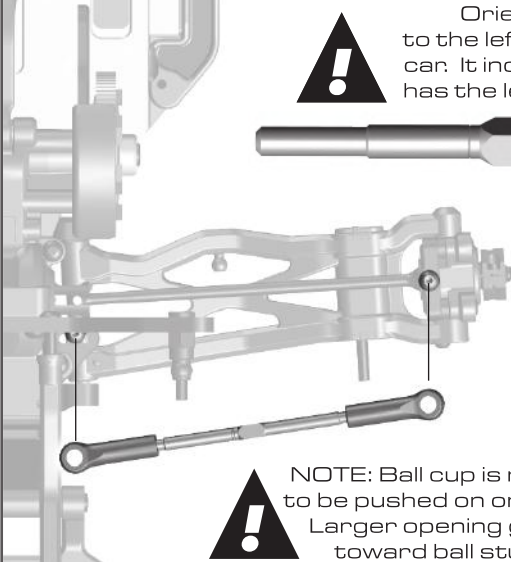

Rear Camber Turnbuckle 50.70mm



Build x2 (right and left side)

:: Bag 9 - Step 1

91936
FT 13mm
Shock Piston,
2mm [2x1.6]
"front"



31510
M2 x 4mm
BHCS



89278
2.6mm
Washer



91619
V2 3 x 27.5
Shock Shaft
TiN "front"



Mount the shock pistons with the number facing up!



Racers Tip:

Use a marker over the numbers on the pistons to make them easily visible!

91938
FT 13mm
Shock Piston,
2mm [2x1.8]
"rear"



31510
M2 x 4mm
BHCS



89278
2.6mm
Washer



91623
V2 3 x 35
Shock Shaft
TiN "rear"



Build x2 front shocks

Build x2 rear shocks

:: Bag 9 - Step 2

91922
13x27.5mm
Shock Bodies
"front"



91996
13mm
Shock Cap
O-Ring



Lightly rub shock oil on the O-ring before installation!



Racers Tip:

Coating the X-rings with green slime (#1105) helps seal & reduce X-ring swell! **Green slime not included in kit!**

91493 **X-Ring**



91996
13mm Shock
Spacer



#1105
green slime



91996 **13mm Shock
Hat Bushing**



31327
VCS3 Shock
Bottom Cap



Build x2 front shocks

91996
13mm
Shock Cap
O-Ring



71158
13x36mm
Shock Bodies
"rear"



91493 **X-Ring**



91996
13mm Shock
Spacer



#1105
green slime



91996 **13mm Shock
Hat Bushing**



31327
VCS3 Shock
Bottom Cap



Build x2 rear shocks

:: Bag 9 - Step 3



Shock fluid

#1105
green slime



There are 3 lengths of shock eyelet in the kit. Pay attention to length when building as these affect your droop and uptravel.

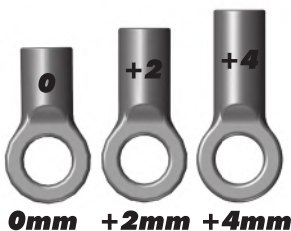

0mm +2mm +4mm



Lightly rub shock fluid or green slime on threads



91997
Shock Eyelets
Front Shocks
+2mm



91819
Shock
Pivot Ball



Build x2 front shocks



91997
Shock Eyelets
Rear Shocks
+2mm



91819
Shock
Pivot Ball



Build x2 rear shocks

:: Bag 9 - Step 4

Shock fluid

Front Shock: 30wt #5422
Rear Shock: 30wt #5422

Steps 2-3 **Steps 4-5** **Steps 6-7** **Step 8**

91926
13mm
Shock Cap

JC 2701-1

Shock Bleeding Steps:

1. Before assembly, get each bleed screw and thread it 1-2 turns into the shock cap, then remove the screw. This will make it easier when you are bleeding your shocks.
2. Pull shock shaft down.
3. Fill shock body 3/4 full with silicone shock fluid.
4. Slowly move the shock shaft up and down to remove air from under the piston.
5. Wait for bubbles to come to surface.
6. Fill shock body to top with silicone shock fluid.
7. Place a drop of oil in the cap and on cap threads.
8. Install cap (without bleed screw) and tighten completely.
9. Slowly compress shaft all the way to bleed excess silicone shock fluid out the hole in the cap (use rag around shock to catch excess fluid).
10. Install M2x4mm button head screw until snug while shaft is fully compressed.

31510
M2 x 4mm
BHCS

Stroke

Stroke
Front: 28.5mm
Rear: 34.5mm

Steps 9-10

:: Bag 9 - Step 5

91928

13mm
Threaded
Collar
O-ring

JC 2702-1

91996

13mm
Threaded
Collar

Build x4

71161
13mm Front
Spring, Gray
L54mm
(4.60lb)

71163
13mm Rear
Spring, Green
L72mm
(2.35lb)

Racers Tip:

Use your finger to rub shock fluid on the O-ring for smoother adjustment!

:: Bag 9 - Step 6

Front: 4.80mm

91966
13mm Shock
Spring Cup
"Front - 5mm"

Build x2 front shocks

Rear: 8.00mm

91966
13mm Shock
Spring Cup
"Rear - 5mm"

Build x2 rear shocks

#91926 13mm Shock Spring Cups

0mm **5mm** **9mm**

:: Bag 9 - Step 7

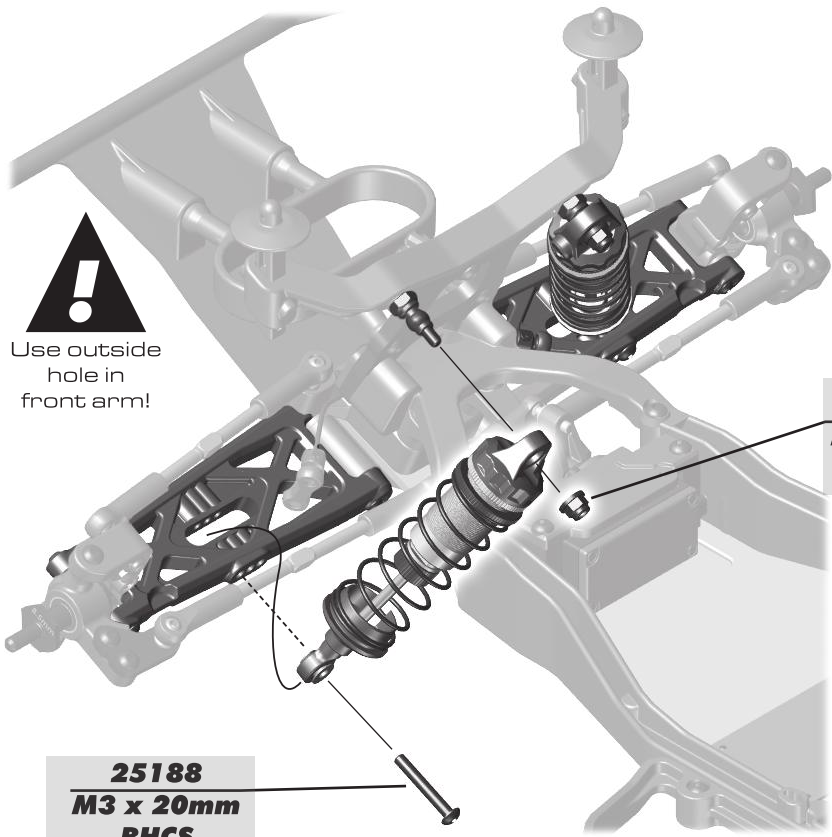

!
Use outside
hole in
front arm!

25612
M3 Locknut
w/Flange

25188
M3 x 20mm
BHCS

Build x2 (right and left side)

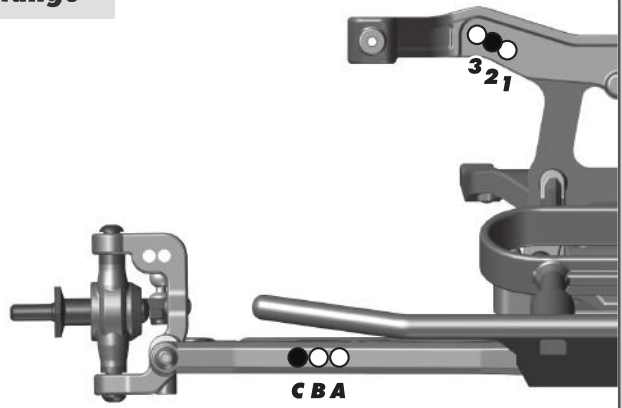

:: Bag 9 - Step 8

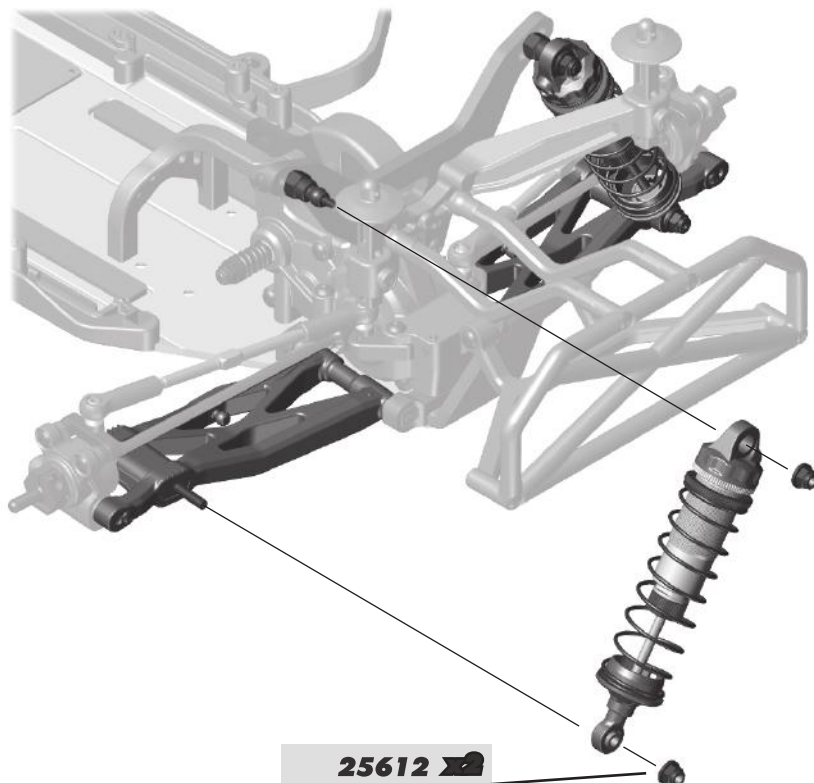

!
Make sure the
flange on the
shock pivot ball is
towards the rear
arm.

25612
M3 Locknut
w/Flange

Build x2 (right and left side)

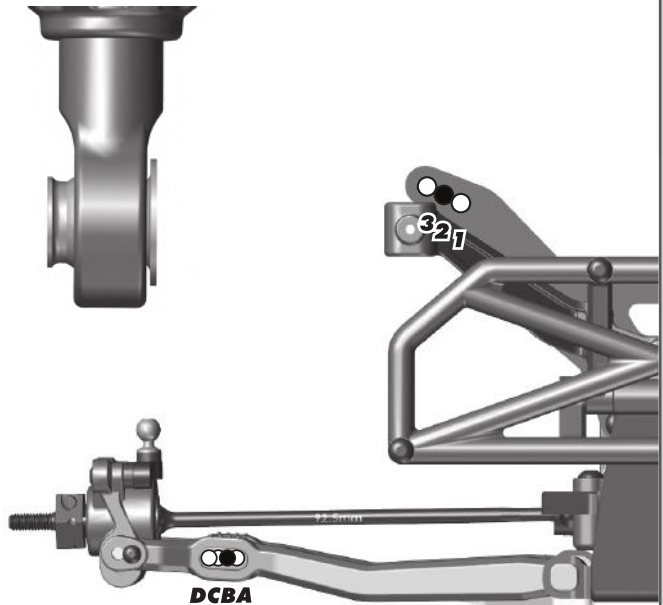

:: Bag 10 - Step 1

▲
See page 25 for
gear mesh setting
instructions!

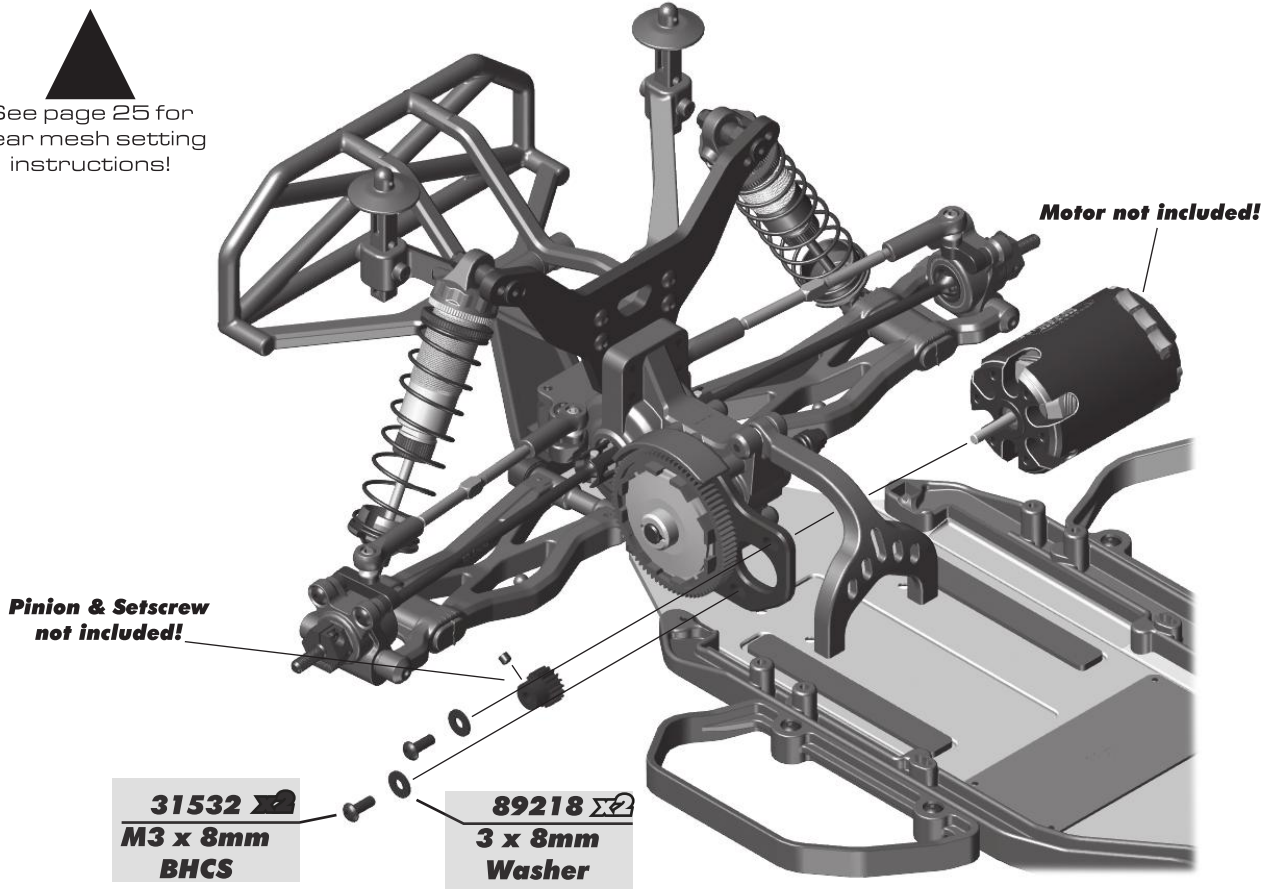

:: Bag 10 - Step 2

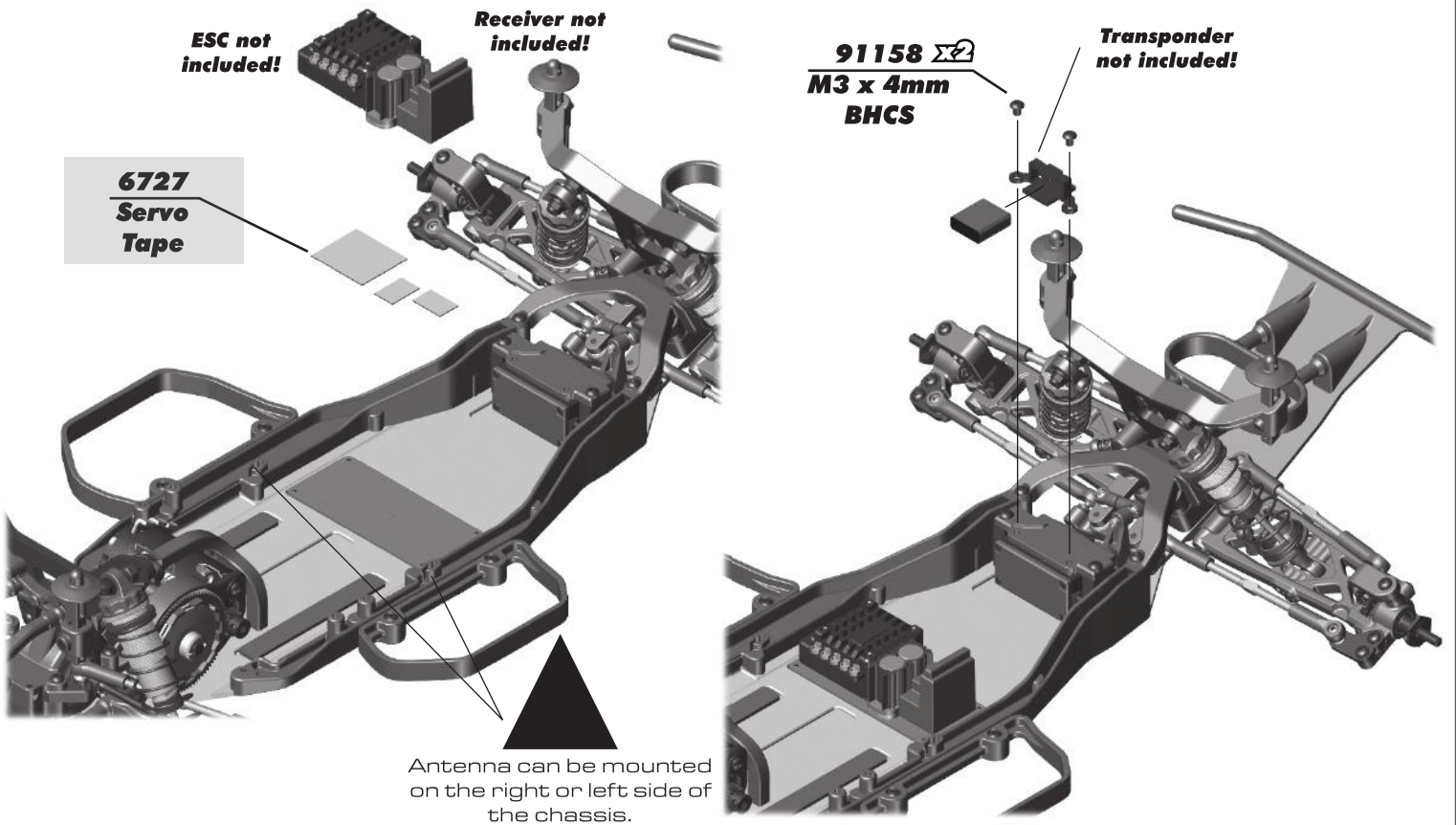

:: Bag 10 - Step 3



Fan mount options:
 #1 - Laydown gearbox - **Use this mount**
 #2 - Layback gearbox
 #3 - Endbell location
 #4 - Plug (no fan)



91978
Fan Mount
#1

Fan not included!

89203
M3 x 16mm
BHCS

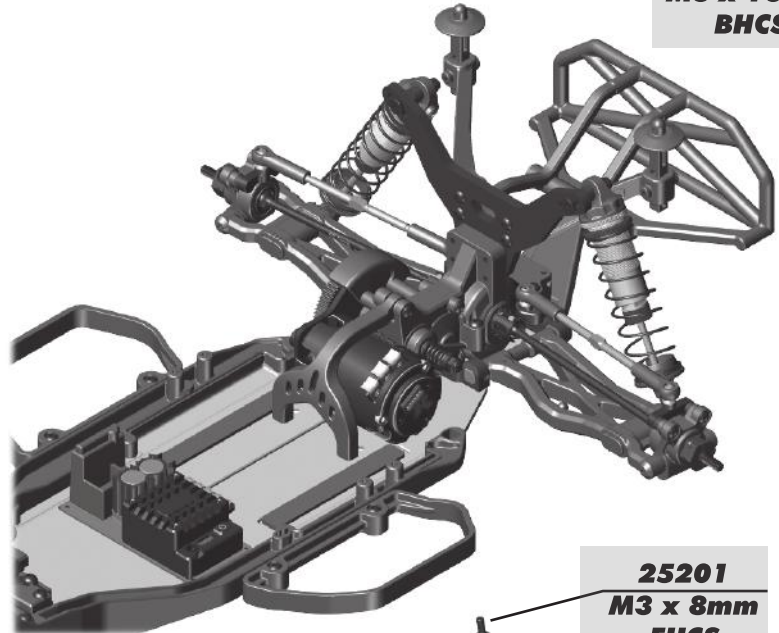

25201
M3 x 8mm
FHCS

:: Bag 10 - Step 4



Make sure the battery strap shoulder screw is flush with the top of your battery pack!

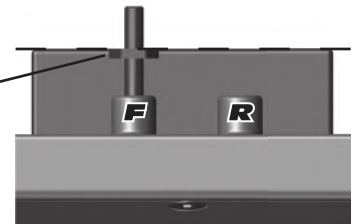

Battery
not included!

91730 x2
Battery Strap
Shoulder
Screw

NOTE: Adjust battery strap nut to fit battery pack. Loosen 3x6mm BHCS to change battery width.

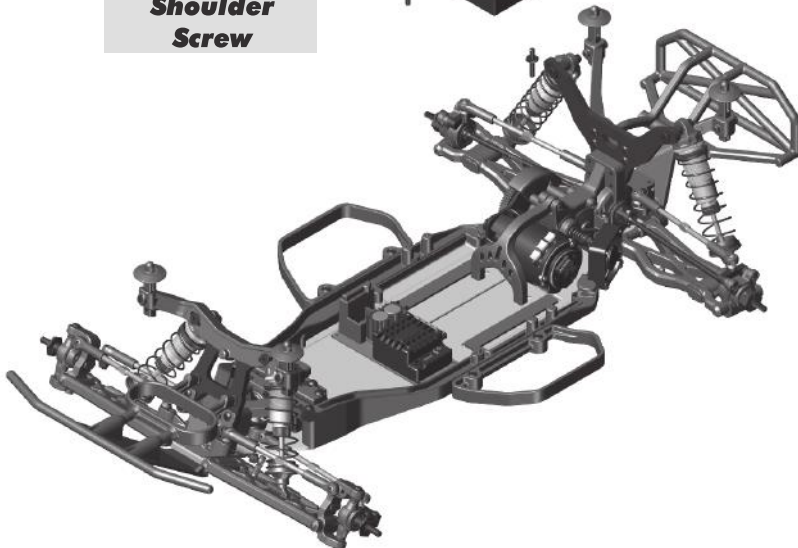

89218 x2
3 x 8mm
Washer

31531 x2
M3 x 6mm
BHCS

91731
Battery
Strap, B6

91731 x2
B6 Battery
Strap Nut

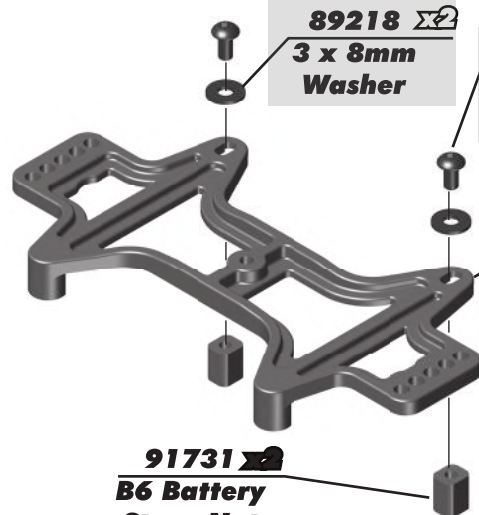

:: Bag 10 - Step 5

Front

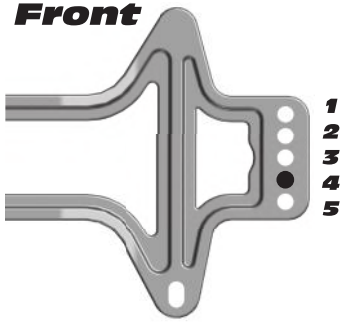

91729 
Thumb Screw, B6

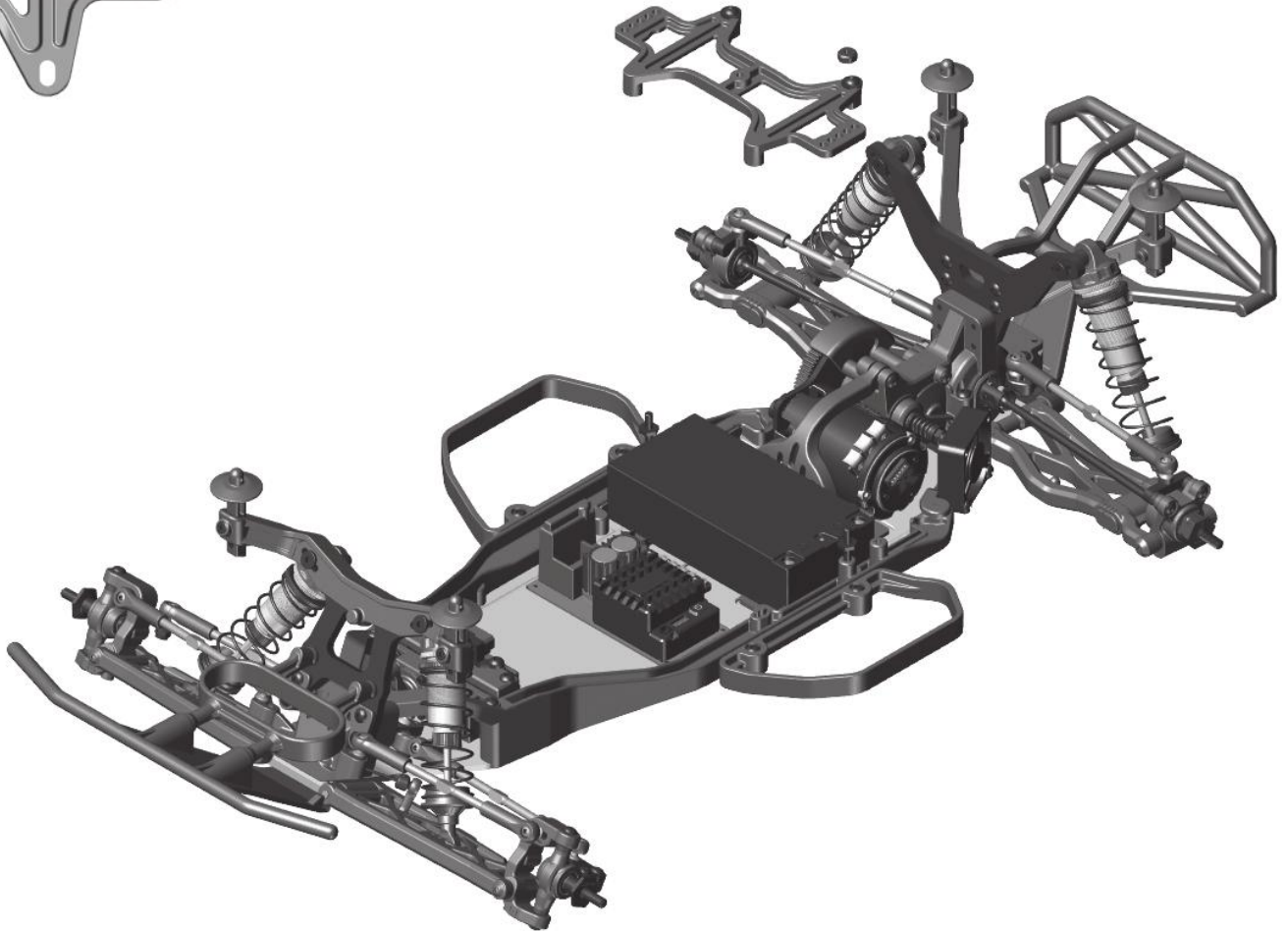

:: Bag 10 - Step 6 - Optional Chassis Brace Configuration *NOT INCLUDED

91885
Rod End



91723
Turnbuckle
3x48mm



91885
Rod End



25612
M3 LockNut
w/Flange



91819 
Shock
Pivot Ball



!!OPTION!!
 Tune for more
 chassis flex

Battery Brace Turnbuckle
Varies with battery position
3F - 29mm



Installation: Remove the plastic chassis brace (3 screws) and install the battery brace turnbuckle with M3x16mm FHCS

Pro Tip: Set the turnbuckle length based on battery position, adjust the length as needed to mate with the gearbox.

25204
3 x 16mm
FHCS



NOT INCLUDED

:: Bag 10 - Step 7

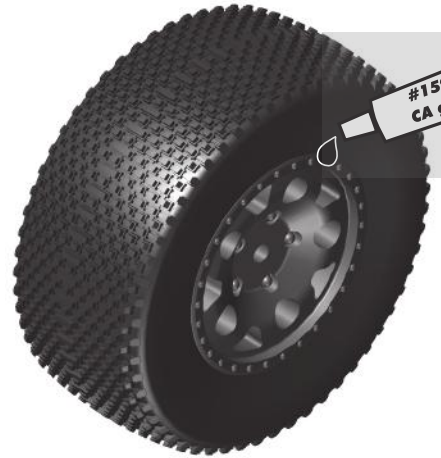

Wheels, Tires, and Inserts are not included!



Carefully apply CA glue (tire adhesive) to the tire bead on the side. Do one side at a time, allowing it to dry before gluing the other side!

CA glue not included!

Build 4

:: Bag 10 - Step 8

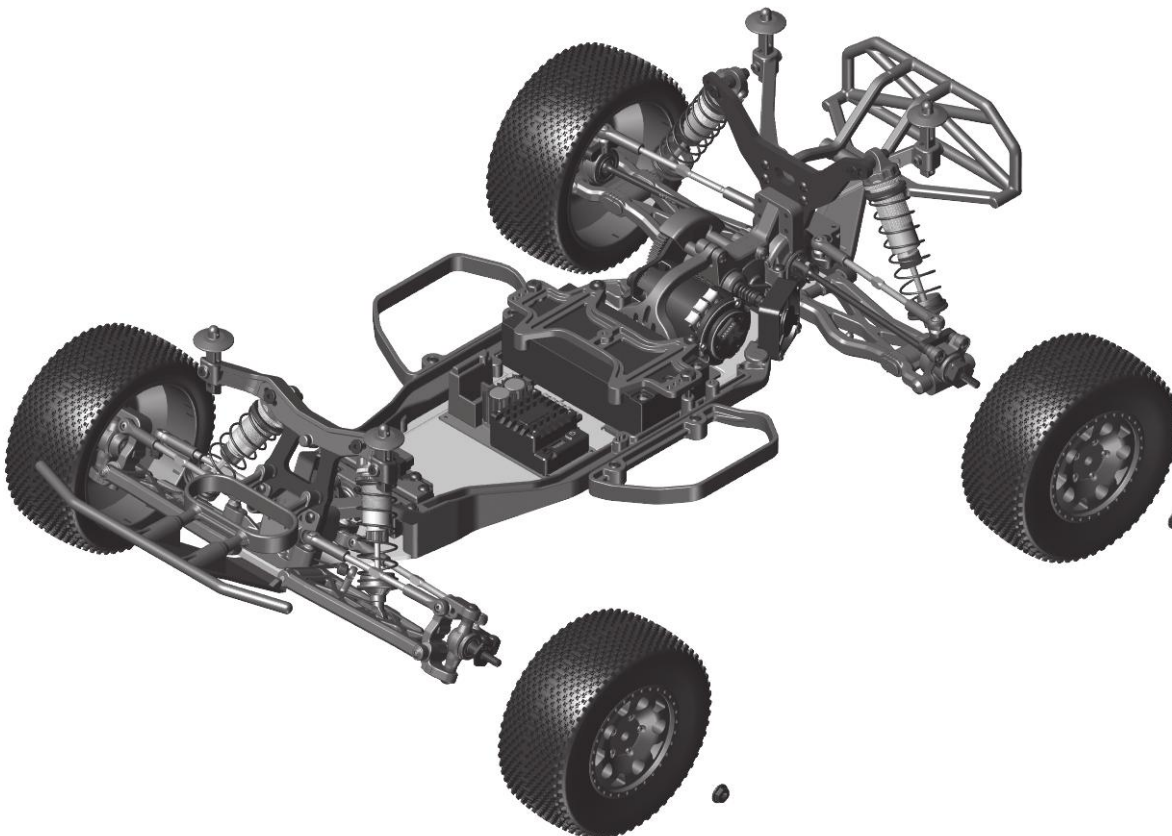

91150
M4 Low Profile Serrated Steel Wheel Nuts

:: Notes

A large, empty rectangular area intended for writing notes, framed by a thin black border.

ss Tuning Tips

Painting:

Your Kit requires a clear polycarbonate body and polycarbonate specific paint. You will need to prep the body before you can paint it. Wash the **INSIDE** thoroughly with warm water and liquid detergent (do not use any detergents with scents or added hand lotion ingredients!). Dry the body using a clean, soft, lint-free cloth. Use the supplied window masks to cover the windows from the **INSIDE** of the body (RC cars get painted on the inside). Using high quality masking tape, apply tape to the inside of the body to create a design. Spray [use either rattle can or airbrush] the paint on the inside of the body (preferably dark colors first, lighter colors last). **NOTE: ONLY** use paint that is recommended for polycarbonate plastics. If you do not, you can destroy the body! After the paint has completely dried (usually after 24 hours), cut the body along the trim lines. Make sure to drill or use a body reamer to make the holes for the antenna if needed! Use body clips to attach the body to the chassis. Use hook and loop tape to the side rails to secure the body.

Tips for Beginners:

Before making any changes to the standard setup, make sure you can get around the track without crashing. Changes to your vehicle will not be beneficial if you can't stay on the track. Your goal is consistent laps. Once you can get around the track consistently, start tuning your vehicle. Make only **ONE** adjustment at a time, testing it before making another change. If the result of your adjustment is a faster lap, mark the change on the included setup sheet (make additional copies of the sheet before writing on it). If your adjustment results in a slower lap, revert back to the previous setup and try another change. When you are satisfied with your vehicle, fill in the setup sheet thoroughly and file it away. Use this as a guide for future track days or conditions. Periodically check all moving suspension parts. Suspension components must be kept clean and move freely without binding to prevent poor and/or inconsistent handling.

Rear Arm Mount Pill Insert Setup:

The aluminum rear arm mounts utilize eccentric pill inserts to make fine adjustments to anti-squat, toe, pin heights, and pin width. Adjustments can be made using the supplied inserts (#92014)

Standard Position

Use this position as a reference when changing pill locations.

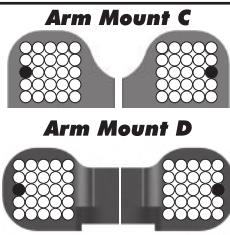

Toe: 3°
Anti-squat: 1°
Roll Center: +0
Pivot Width: +0

Insert Hole Locations

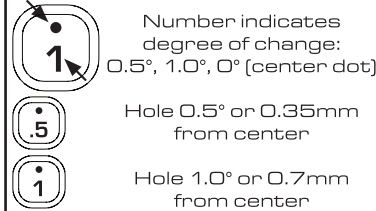

Anti-squat Angle

More angle = More anti-squat
Less angle = Less anti-squat
Shown in 1° changes

C Mount	D Mount	
		= 1°
		= 0°
		= -1°
		= 2°
		= 1°
		= 0°
		= -3°
		= 2°
		= 1°

Possible Insert Locations

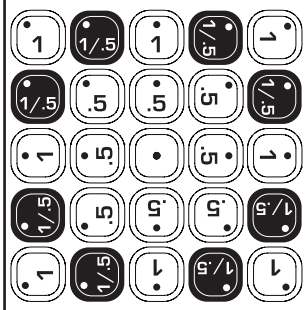

Pin Width

More distance = wider pivot
Less distance = narrow pivot
*Note: For pin width -1.4mm, use 67mm CVA driveshafts

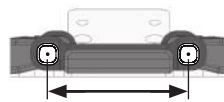

C Mount	D Mount	
		= +1.4mm
		= +0.7mm
		= 0mm
		= -0.7mm
		= -1.4mm*

Toe Angle

More angle = More toe in
Less angle = Less toe in
Shown in 1° changes

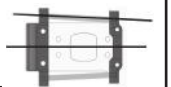

C Mount	D Mount	
		= 3°
		= 4°
		= 5°
		= 2°
		= 3°
		= 4°
		= 1°
		= 2°
		= 3°

Pin Height

Higher pin = Higher roll center
Lower pin = lower roll center

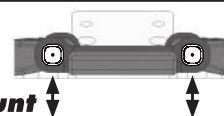

C Mount	D Mount	
		= +0.7mm
		= +0.35mm
		= 0mm
		= -0.35mm
		= -0.7mm



For additional setup tips, please visit our website by using the link or QR code below.

<http://bit.ly/B6PillChart>



ss Tuning Tips (cont.)

Motor Gearing:

Proper motor gearing will result in maximum performance and run time while reducing the chance of overheating and premature motor failure. The gear ratio chart lists recommended **starting gear ratios** for the most widely used motor types. Gear ratios will vary depending upon motor brand, wind, and electronic speed control. Consult your motor and electronic speed control manufacturers for more information.

Team Associated is not responsible for motor damage due to improper gearing.

SC6 Gear Ratio Chart (Internal Gear Ratio 2.60:1)

Motor	Pinion	Spur	Final Drive Ratio
21.5 Reedy S-Plus Brushless	30	75	6.50:1
17.5 Reedy S-Plus Brushless	26	78	7.80:1
13.5 Reedy S-Plus Brushless	25	81	8.42:1
10.5 Reedy 540-M4 Brushless	24	81	8.78:1
9.5 Reedy 540-M4 Brushless	23	81	9.16:1
8.5 Reedy 540-M4 Brushless	22	81	9.57:1
7.5 Reedy 540-M4 Brushless	21	81	10.03:1
6.5 Reedy 540-M4 Brushless	20	81	10.53:1

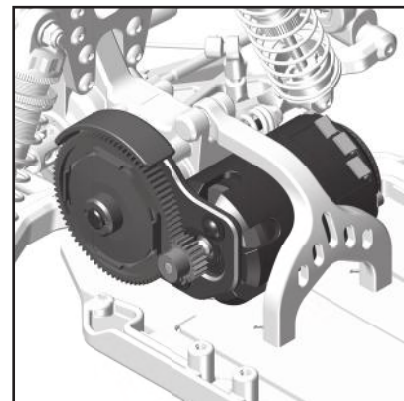

Set The Gear Mesh:

You should be able to rock the spur gear back and forth in the teeth of the pinion gear without making the pinion gear move. If the spur gear mesh is tight, then loosen the #31532 screws (p. 19) and move the motor away, then try again. A gear mesh that is too tight or too loose will reduce power and damage the gear teeth.

Diff Height Adjustment:

Diff height adjustment (p.12).

On high grip surface when using low ride heights, a higher diff height would be a good option.

On low grip surface when using high ride heights, a lower diff height would be better.

Gear Box Type:

Selecting the correct gear box is dependent on the type of track it will be used on. The optional 4-gear standup gear box is for the lowest grip conditions. This gear box moves the weight towards the rear of the car and also uses the rotation of the motor to transfer weight to the rear while on-power. The 3-gear standup gear box also moves the weight towards the rear of the car, but in this configuration, the motor's rotation helps with on-power steering.

The laydown gear box is used on high grip conditions when on-power steering and stability are most important.

This gear box will change directions the quickest and generate the most steering. Layback is used for most indoor clay track conditions.

Slipper Clutch:

The assembly instructions give you a base setting for your clutch. Turn the nut on the shaft so that the end of the top shaft is even with the outside of the nut. At the track, tighten or loosen the nut in 1/8 turn increments until you hear a faint slipping sound for 1-2 feet on takeoffs. Another popular way to set the clutch is to hold both rear tires firmly in place and apply short bursts of throttle. If the clutch is properly set, the front tires should lift slightly up off the surface.

Caster:

Caster describes the angle of the caster block as it leans toward the rear of the vehicle. Positive caster means the kingpin leans rearward at the top. The kit includes three inserts to adjust caster angle at the caster block, 0°, 2.5°, and +5°. The total caster angle is the sum of the kick-up angle and the caster block angle. Standard total caster angle for the B6 is 30°, with 25° kick-up and +5° caster block angle.

For less entry steering and more exit steering, try 0° caster block angle.

Front Camber:

Camber describes the angle at which the tire and wheel rides when looked at from the front. Negative camber means that the tire leans inward at the top. A good starting camber setting is -1°. Positive camber, where the top of the tire is leaning out, is not recommended.

A camber gauge can be used to more accurately set camber.



Testing camber with camber gauge

Rear Camber:

Camber describes the angle at which the tire and wheel rides when looked at from the back. Negative camber means that the tire leans inward at the top. A good starting camber setting is -1°. Adding a small amount of positive camber, where the top of the tire is leaning out, will tend to improve straight-line acceleration on loose tracks.

A camber gauge can be used to more accurately set camber.

FIND IT ON ASSOCIATEDELECTRICS.COM

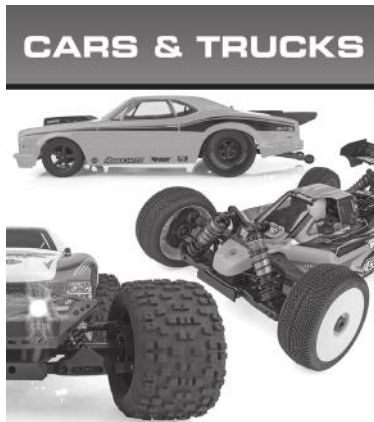

Vehicle Spare Parts

GO TO:

[AssociatedElectrics.com](#) →
[Team Associated tab](#) →
[Cars & Trucks](#) →
[Scroll to your vehicle](#) →
[Parts & Accessories link](#)



Setups and Manuals

GO TO:

[AssociatedElectrics.com](#) →
[Team Associated tab](#) →
[Manuals & Setups](#) →
[Scroll to your vehicle](#)



Tuning Guides & Tips

GO TO:

[AssociatedElectrics.com](#) →
[Support](#) →
[A-Team Apps](#)



Associated Electrics, Inc.

21062 Bake Parkway Lake Forest, CA 92630 USA

call: (949) 544-7500 - fax: (949) 544-7501

**Check out the following web sites for all of our kits, current products,
new releases, setup help, tips, and racing info!**

www.AssociatedElectrics.com

FOLLOW US ON SOCIAL MEDIA



TeamAssociated
ReedyPower
ElementRC

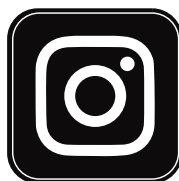

@TeamAssociatedRC
@ReedyPower
@Element_RC



@Team_Associated
@ReedyPower