

INSTRUCTIONAL MANUAL

Configura Advance[®]

Postural Backrest and External Laterals

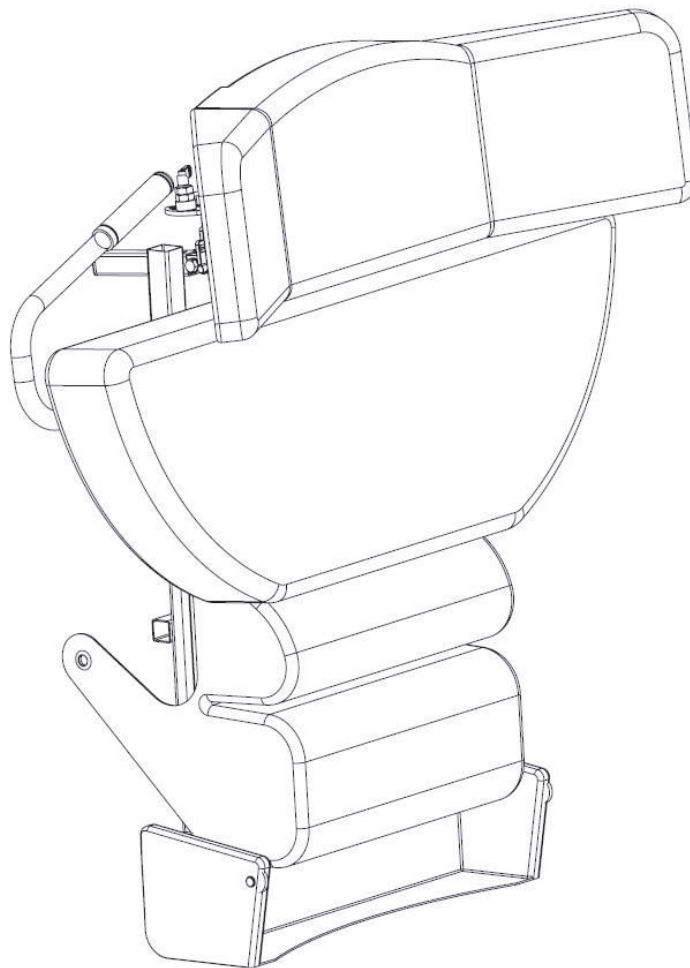

Contents

TITLE	PAGE
Welcome	2
Technical Specification	3
Assembly of Postural Backrest	4
Setup of Postural Backrest	7
Assembly of External Laterals	8
Setup of External Laterals	8
Functionality Check	9
Cleaning and Disinfection	9
Guarantee	9
Disposal	9
Contact details	10

Design Policy and Copyright

® And ™ are trademarks belonging to Accora Ltd unless otherwise stated. As our policy is one of continuous improvement, we reserve the right to modify designs without prior notice. © Accora Ltd 2020.

Welcome

Dear Customer,

Thank you for purchasing an Highgate Healthcare product. We feel sure that this product will exceed your expectations.

This manual is important for understanding how to use your new Configura Advance Postural Backrest and External Laterals; please read it before use. If you need further information, please contact Highgate Healthcare.

See Contact Details in Section 10.

Before using the Configura Advance Postural Backrest, you must read and understand the instructions in this user manual. All actions and handling of the Configura Advance Postural Backrest must be performed in accordance with the instructions in this manual.

Any actions that are inconsistent with the manual are performed at your own risk and Highgate Healthcare shall not be liable for any injury or damage. Please ensure that the manual is available to users and operators throughout this products service life.

This instruction manual must be read in conjunction with the Configura Advance chair instruction manual (IFU-SC3-001US).

Warning

A clinical assessment and risk assessment MUST be carried out by suitably trained and qualified personnel before fitting this accessory to the chair.

Refer to the Configura Advance chair instruction manual (IFU-SC3-001US) for full list of safety warnings.

NOTE: For clarity, the Postural Backrest and External Laterals are generally shown in this Instruction manual without cushions.

Technical Specification

The table below lists the part numbers for the Advance Postural Backrest and External Laterals.

Part number	Description
CA2709	Postural backrest includes all metal frames and cushions, grey
CA2705	External laterals, black, set of 2

Figure 1 shows the position of the adjustable parts of the postural backrest and the external laterals.

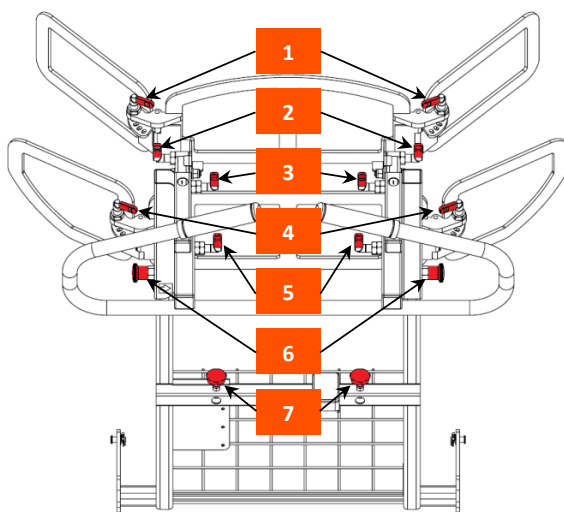

FIGURE 1 - backrest adjustments

1. Top wing open/close adjustment ClickLock plunger.
2. Top wing tilt angle adjustment ClickLock plunger.
3. Top wing depth adjustment lock plunger.
4. Middle wing open/close adjustment ClickLock plunger.
5. Middle wing depth adjustment ClickLock plunger.
6. Wing height adjustment lock plunger.
7. Lateral support thumb screw.

Two types of locking mechanism are used:

- ClickLock plunger (Figs 2 & 3).
- Lock plunger (Figs 4 & 5).

To unlock the ClickLock plunger, turn the plunger through 180 degrees; the plunger will lift out and lock into the unlocked position.

To lock the ClickLock plunger, turn the plunger through 180 degrees; the plunger will drop into the locked position.

To unlock the lock plunger, pull out and hold.

To lock the lock plunger, release and the plunger will drop into the locked position.

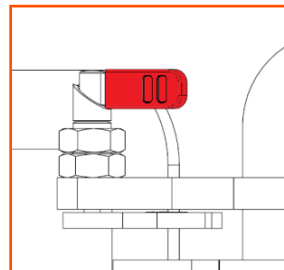

Figure 2 - ClickLock plunger locked

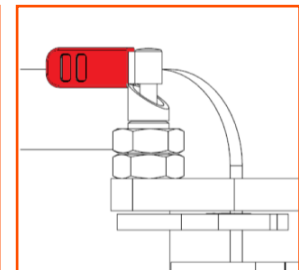

Figure 3 - ClickLock plunger unlocked

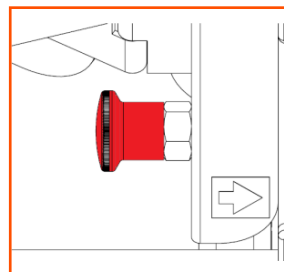

Figure 4 - lock plunger locked

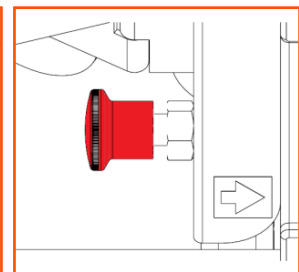

Figure 5 - lock plunger locked

Assembly of Postural Backrest

1. Remove the chair sidepieces. Pull out the locking plunger (Fig 6, Item 1) located under the seat of the chair on each side and rotate 90 degrees to lock it open. Release the hand screw (Fig 6, Item 2) on each side of the chair. Pull the sidepieces away from the chair.

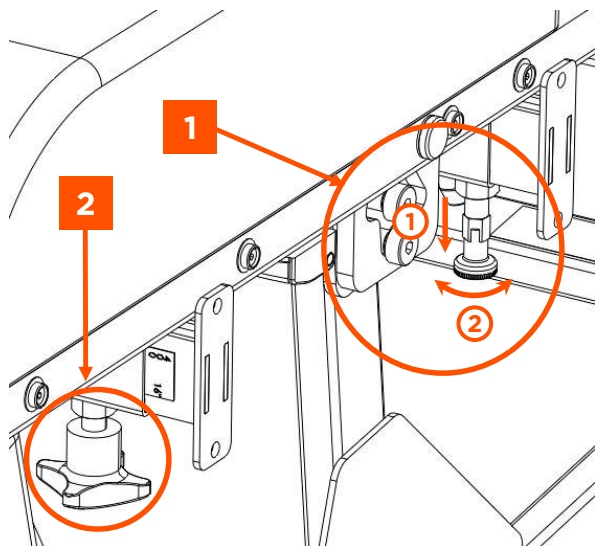

FIGURE 6

2. Remove the Backrest hand lever (Fig 7 Item 1) and the Tilt-in-Space hand lever (Fig 7 Item 2, if fitted) by removing 2 x cross head screws on each lever clamp. Leave the control cables connected and lay the levers to one side. Retain the screws for refitting.

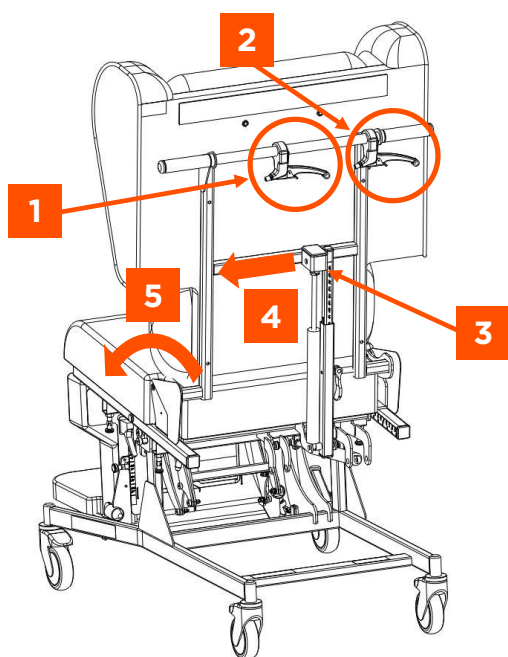

FIGURE 7

3. Remove the R-clip (Fig 8, Item 1) and clevis pin (Fig 8, Item 2) from the top fixing of the backrest actuator (Fig 7, Item 3 & 4; Fig 8).
4. Remove control box if fitted. Press the tab (Fig 9, Item 1) and slide the control box down to release it from the mounting. Lay it aside carefully.
5. Remove the backrest hinge covers (Fig 10, Item 1) from the backrest pivot points (Fig 10, Item 2). Fold the backrest forwards (Fig 7, Item 5).

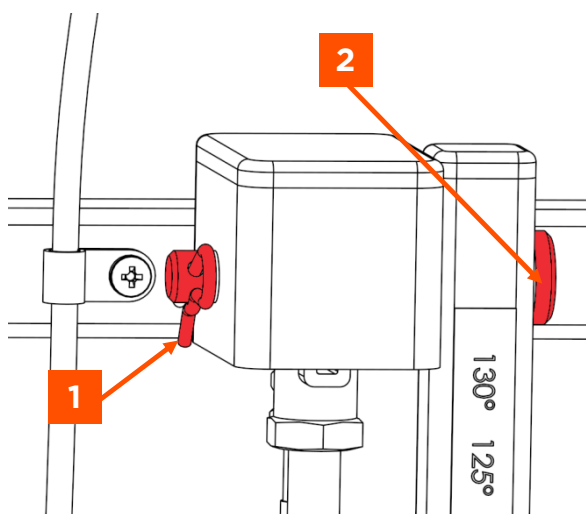

Figure 8 - top of backrest actuator

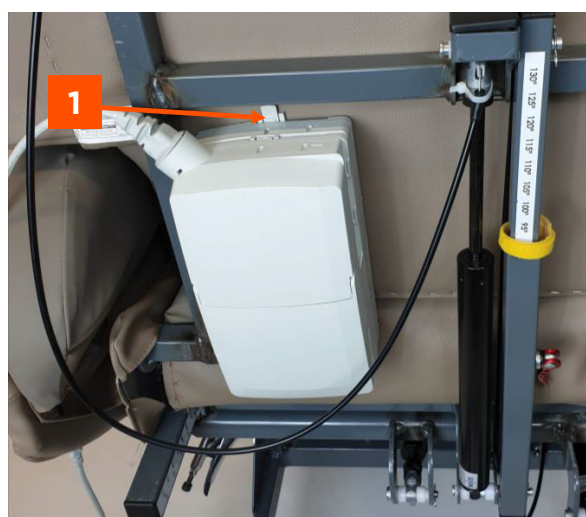

FIGURE 9

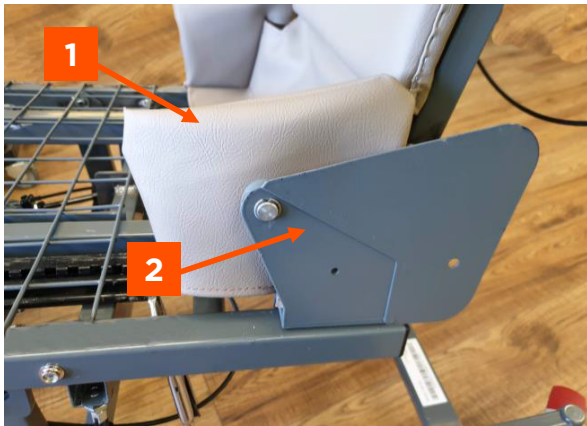

FIGURE 10 - (Seat cushion shown removed for clarity)

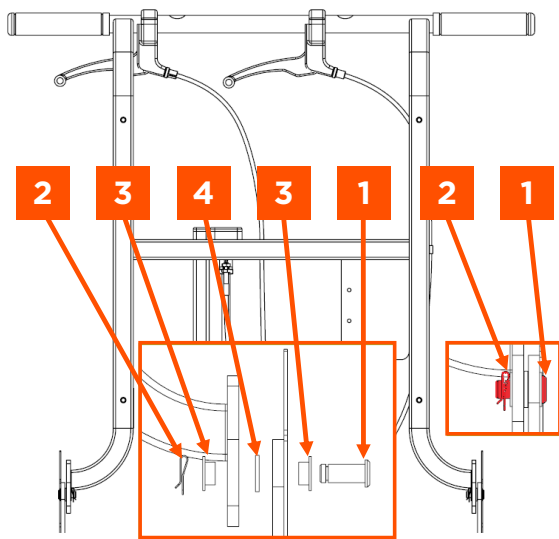

FIGURE 11

6. The backrest hinges each side of the chair are secured with a clevis pin (Fig 11, Item 1), two bushes (Fig 11, Item 3), washer (Fig 11, Item 4) and R clip (Fig 11, Item 2). The bushes should remain in the chair and backrest frame when the pins are removed. Note the order of assembly.
7. Remove the pins, washers, and R clips from both hinges (Figure 12) and lift off the backrest. Retain the pins, washers, and R clips to use with the postural backrest.
8. Place the postural backrest on the chair frame (Figure 13) and refit the clevis pins and R clips (Figure 11) to the hinges. Ensure bushes are in place and the R clip is on the inside of the chair.
9. Refit the backrest actuator into the clamp on the postural backrest. Refit the clevis pin and R clip (Figure 8).
10. Refit the backrest hand lever (Fig 14, Item 1) and Tilt-in-Space hand lever (Fig 14, Item 2) in

the positions shown in Figure 14. Ensure the Tilt-in-Space operating cable (Fig 15, Item 1) is routed between the backrest and backrest actuator assembly.

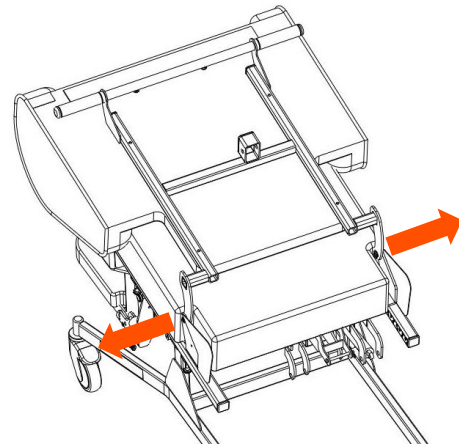

FIGURE 12

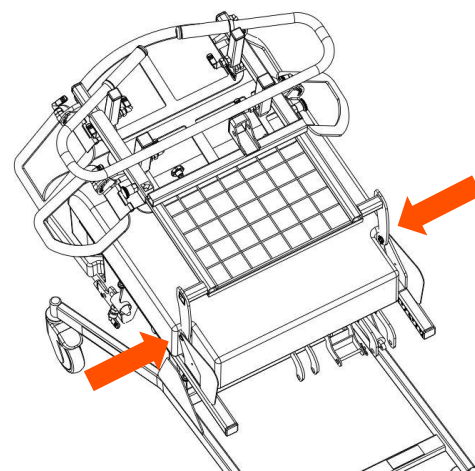

FIGURE 13

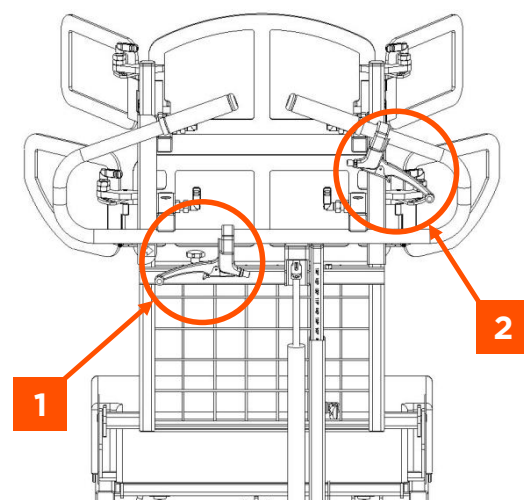

FIGURE 14

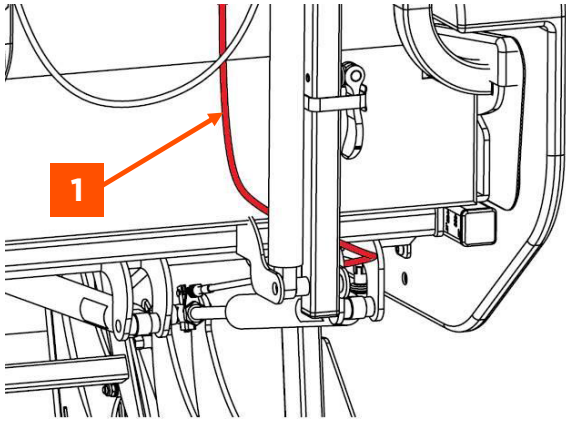

FIGURE 15

11. Refit the control box if required. Place the control box against the plastic fixing bracket on the Postural Backrest, locate the control box in the sliding slot, then move control box upwards. Ensure the fixing tab (Fig 9, Item 1) has located the control box correctly.
12. Fit the backrest hinge covers over the backrest pivot points. To fit this cover, place the first part of the cover (Fig 16, Item 1) over the rear part of the hinge protection plate (Fig 16, Item 2), then pull the front part of the cover (Fig 16, Item 3) down over the hinge.

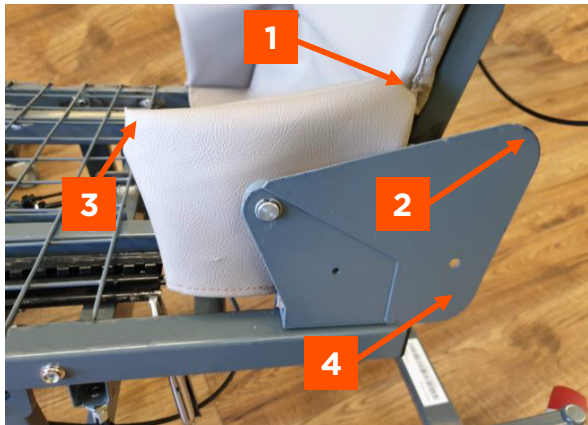

FIGURE 16 - (Seat cushion shown removed for clarity)

13. Figure 17 shows the backrest hinge cover from the inside. Place the lower pocket of the backrest hinge cover (Fig 17, Item 1) over the lower part of the hinge protection plate (Fig 16, Item 4) to secure the hinge cover in place.
14. Repeat steps 11 and 12 to secure the cover on the other side.



FIGURE 17

15. Refit the sidepieces. To fit the sidepieces, pull out the plunger located under the seat on one side of the chair (Fig 6, Item 1) and rotate it through 90 degrees to lock it open.
16. Undo the hand screw (Fig 6, Item 2).
17. Locate the two sidepiece fixing bars into the chair frame. Push the sidepiece all the way in (Fig 18) and release the plunger by rotating it until the cap engages with the base (Figure 19).
18. Ensure the plunger is engaged by moving the sidepiece in and out - the sidepiece should not move.

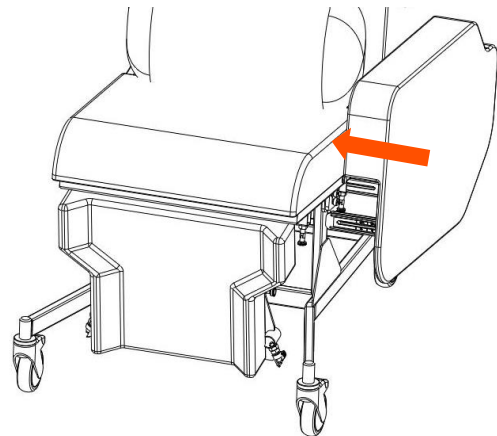

FIGURE 18

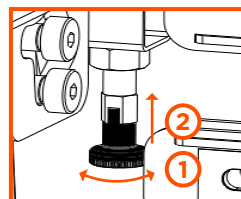

FIGURE 19

19. Tighten the hand screw to secure the sidepiece (Fig 6, Item 2).
20. Repeat steps 14 to 18 to fit the other sidepiece.
21. Carry out a functionality check as described in Section 7.

Setup of Postural Backrest

1. Height - to adjust the backrest height, pull out and hold the two lock plungers shown in red in Figure 20. Move the backrest to the desired height, then release the plungers to lock the backrest in position (Fig 1, Item 6).

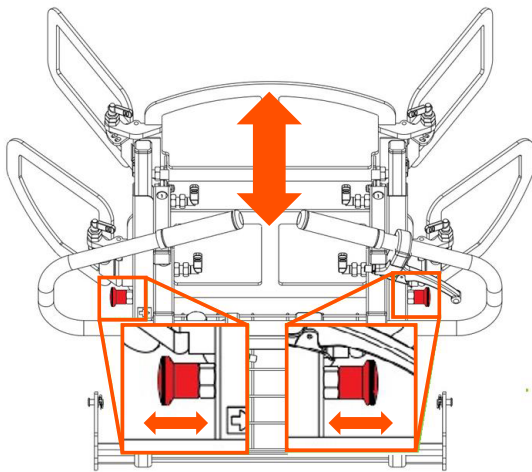

FIGURE 20

2. Depth of top and middle pillows - to adjust the pillow depth, unlock the two ClickLock plungers shown in red in Figure 21 that correspond with the pillow to be moved and move the backrest pillows to the desired depth setting. Release the plungers to lock the pillow depth (Fig 1, Items 3 & 5).

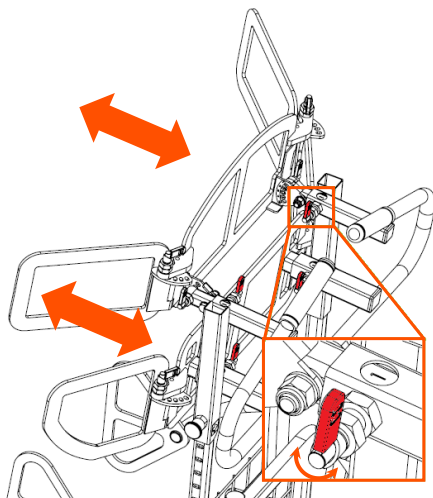

FIGURE 21

3. Angle of outer parts of pillows - to adjust the angle of the outer parts of the pillows unlock the relevant ClickLock plunger shown in red in Figure 22 and adjust to the desired angle. Release the ClickLock plungers to lock the angle adjustment (Fig 1, Items 1 & 4).

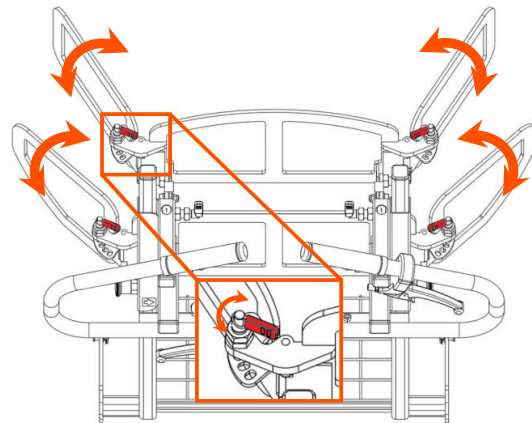

FIGURE 22

4. Inclination of top pillows - to adjust the inclination of the top backrest pillows, release the two ClickLock plungers shown in red in Figure 23 and adjust the angle as desired. Release the ClickLock plungers to lock the angle (Fig 1, Item 2).

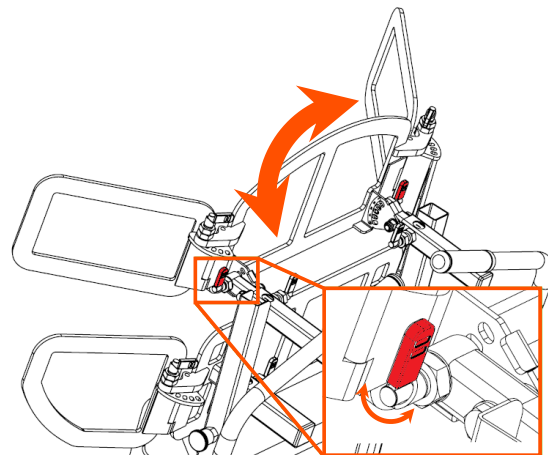

FIGURE 23

Assembly of External Laterals

Slide each external lateral into the locating points (Fig 24, Item 1) on the postural backrest. Secure the External Laterals by tightening the thumb screws shown in red slowly clockwise. Move the external laterals in and out a small amount until a locking position is located. Then tighten the thumb screws down (Fig 24, Item 2).

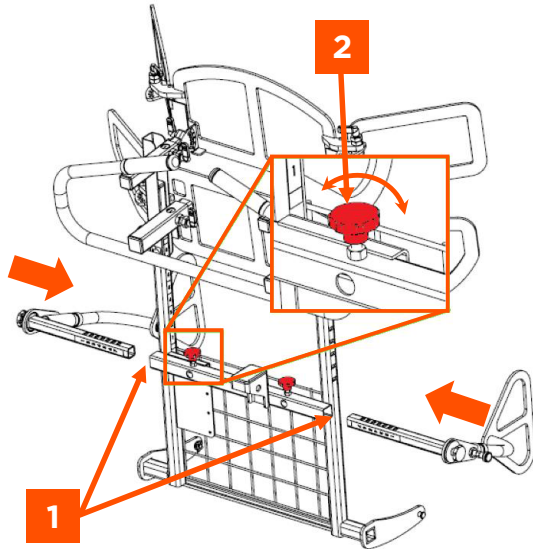

FIGURE 24

Setup of External Laterals

1. Width of the external laterals - turn the thumb screws shown in red (Fig 25, Item 1) counter clockwise to release the external laterals. Adjust the width as required, then tighten the thumb screws (Fig 1, Item7).

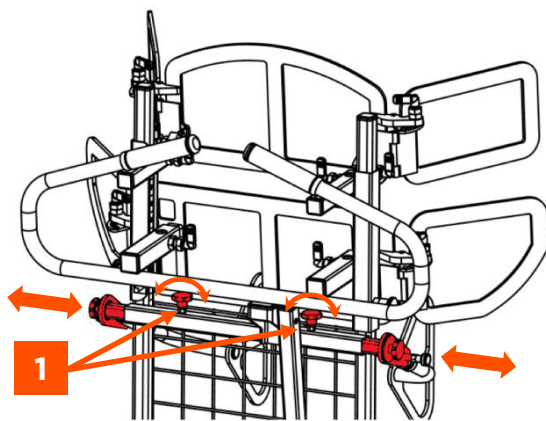

FIGURE 25

2. Angle of the external laterals - turn the thumb screws shown in red (Fig 26, Item 1- there is a second screw hidden from view on the other side of the backrest) to release the external laterals. Move the arm away from the sliding bar and adjust the angle as required. Then locate the arm on to the sliding bar again and tighten the thumb screws.

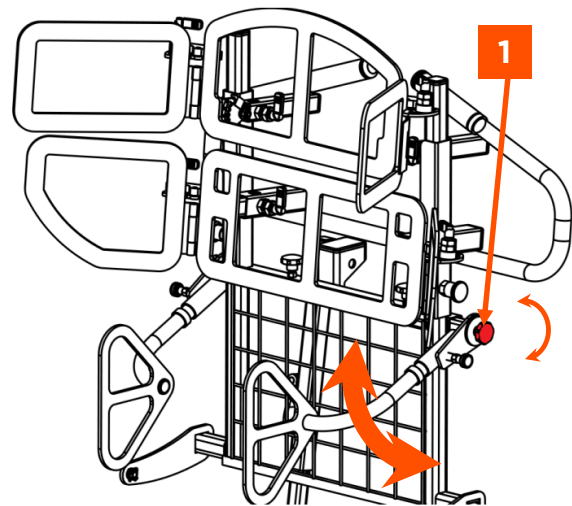

FIGURE 26

3. Removing the external laterals - lift the lock plunger shown in red in Figure 27 and remove the external laterals. To refit, lift the lock plunger and slide the external laterals into position. Release the lock plunger and move the external lateral in and out slightly to ensure the lock plunger engages.

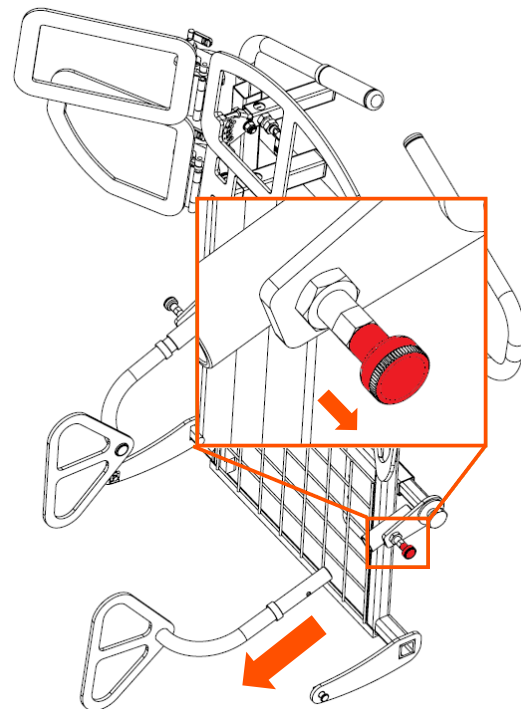

FIGURE 27

Functionality Check

Warning

Functionality check MUST be carried out by suitably trained and qualified personnel.

Check for obstructions around, above and below the chair frame and position the chair so that it can operate through the full adjustment range without any chance of obstruction or entrapment.

Always engage the castor brakes when the chair is stationary or left unattended.

These checks must be carried out after backrest assembly, adjustment, or maintenance.

1. Check the backrest is secure by rocking it backwards and forwards.
2. Check the backrest hinge pins and clips are fitted correctly (Figure 11).
3. Ensure the ClickLock plungers move easily and that the wings adjust through the full range (Figure 1).
4. Check that all lock plungers are located in adjustment holes (Figure 1).

Cleaning and Disinfection

Warning

The chair must be disconnected from the power supply when being cleaned or disinfected.

All functions MUST be tested and approved by a competent person after cleaning or disinfection.

The chair MUST be cleaned and disinfected before re-using the chair for a different patient.

Cleaning Information:

To disinfect the chair, only use detergents designed for use in healthcare e.g. warm soapy water. Do not use abrasives, scourers or other materials that could damage the coating. Do not use corrosives, caustics or strong acids.

Do not use detergents that could alter the structure or behaviour of the plastics (petrol etc.).

Clean by wiping with a damp cloth. Alternatively use Microfibre cleaning cloth without any soap. For extreme soiling use a 5% Sodium Hypochlorite solution.

The chair is not designed for maintenance in automatic chair washers or for cleaning with pressurised water, spraying, showering or steam cleaning.

Highgate Healthcare cannot be liable for any damage or risk of damage if inappropriate cleaning or disinfectant agents are used.

Cleaning procedure:

1. Disconnect the chair from the power supply (if applicable).
2. Move the chair to where cleaning will take place and lock the chair castors.
3. Remove the cushions and any accessories such as profiled headrest, external laterals.
4. Clean as described in the "Cleaning Information".

Guarantee

Model	Warranty period
Configura Advance Postural Backrest & External Laterals	2 Years

Disposal

In the event of the disposal of materials from the chair, end-of-life parts must be disposed of in accordance with current environmental regulations.



At Enable we source quality, affordable and innovative products globally and have them available for fast delivery. But we do more than just provide products.

We give the knowledge and support to help our customers grow their business and deliver better life care.



ENABLE LIFECARE PTY LTD

T 1300 370 370

enablelifecare.com.au