

- Ground
- Power
- LED
- Internal Pin
- SWD Pin
- Digital Pin
- Analog Pin
- Other Pin
- Microcontroller's Port
- Default

- ⚠ **MAXIMUM** current per pin is 7mA
- ⚠ **MAXIMUM** source current is 46mA
- ⚠ **MAXIMUM** sink current is 65mA per pin group

VIN Input voltage to the board.

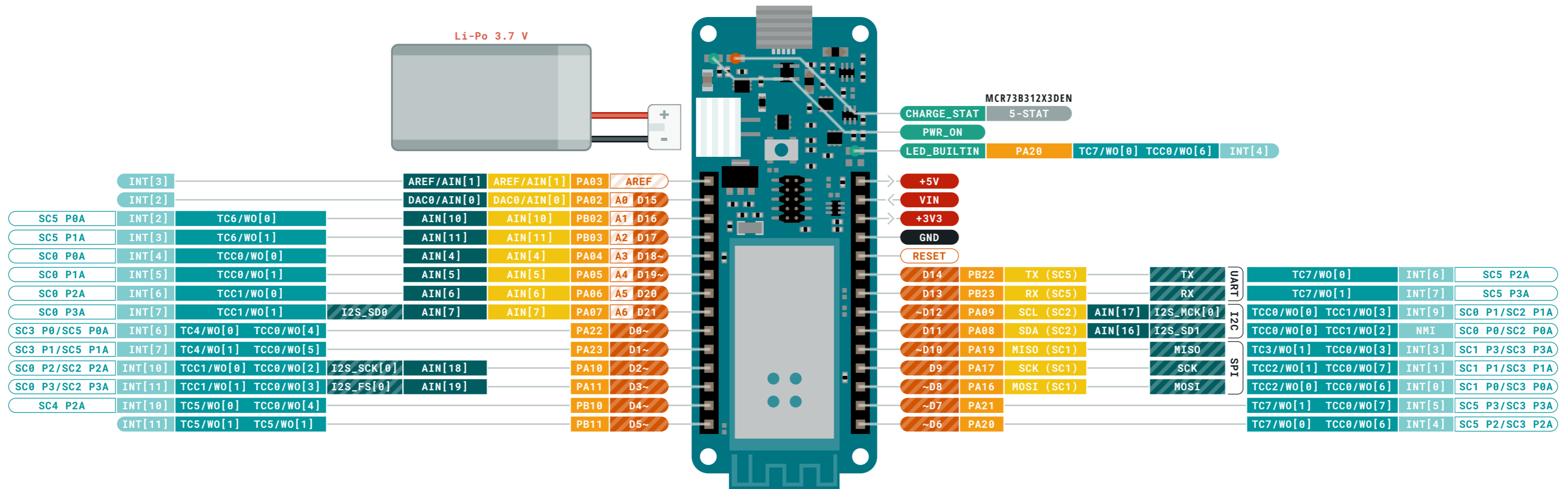



Ground	Digital Pin	Analog
Power	Analog Pin	Communication
LED	Other Pin	Timer
Internal Pin	Microcontroller's Port	Interrupt
SWD Pin	Default	Sercom

- MAXIMUM** current per pin is 7mA
- MAXIMUM** source current is 46mA
- MAXIMUM** sink current is 65mA per pin group

VIN Input voltage to the board.



