

TAKE CONTROL OF THE TRAFFIC WITH THIS

# STOP:bit FOR BBC MICRO:BIT KIT

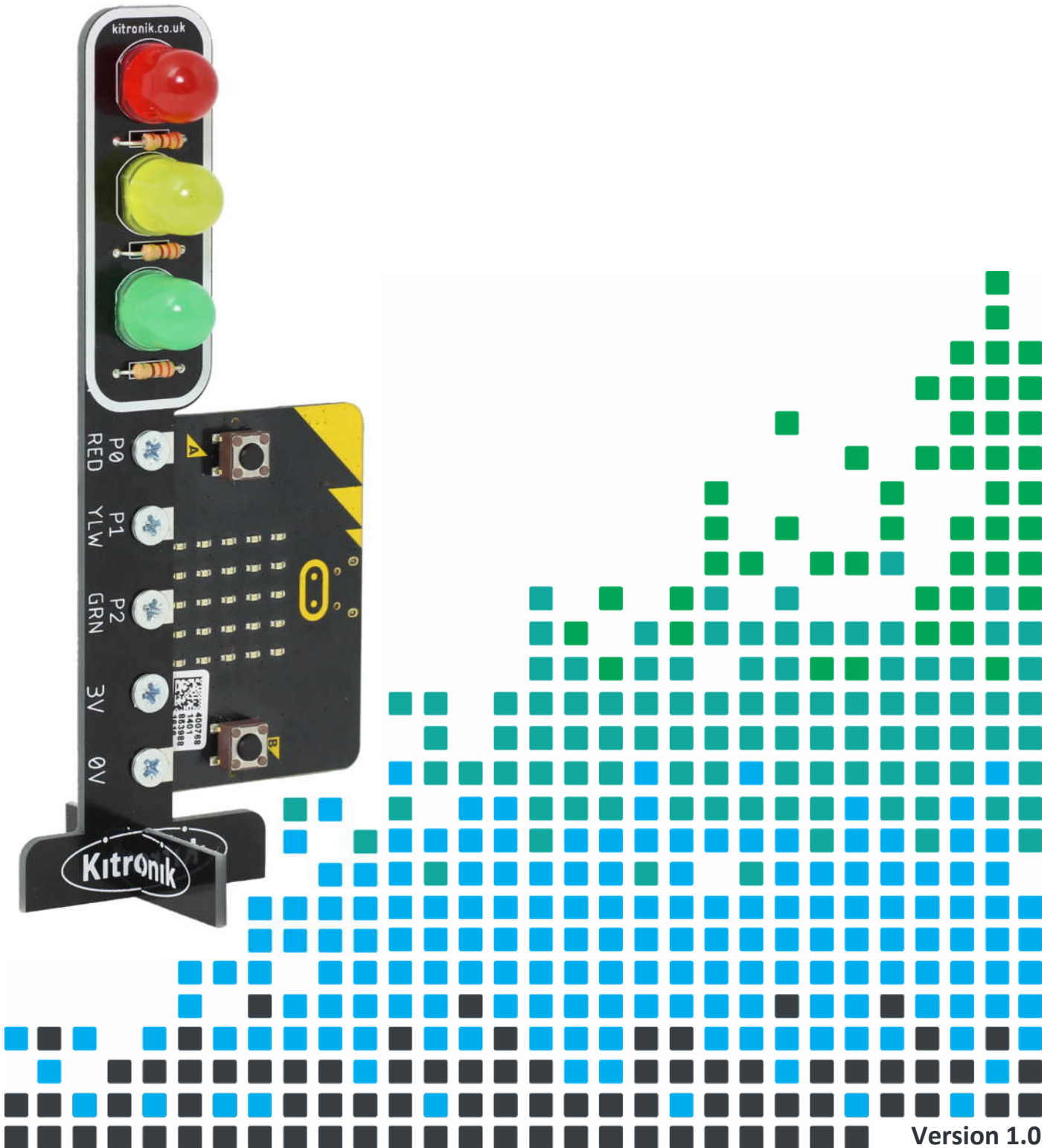

## Index of Sheets

### TEACHING RESOURCES

- Index of Sheets
- Introduction
- Schemes of Work
- Answers
- Soldering in 8 Steps
- Resistor Values
- LEDs & Current Limit Resistors
- LEDs Continued

### ESSENTIAL INFORMATION

- Build Instructions
- Checking Your PCB
- How the Circuit Works
- Online Information



## Introduction

### ***About the project kit***

Both the project kit and the supporting material have been carefully designed for use in KS3 Design and Technology lessons. The project kit has been designed so that even teachers with a limited knowledge of electronics should have no trouble using it as a basis from which they can form a scheme of work.

The project kits can be used in two ways:

1. On their own as a way of introducing electronics and electronic construction to students over a number of lessons.
2. As a cross-curricular resource which can also be used in IT/Computing lessons as part of BBC micro:bit programming exercises.

This booklet, and further resources available on the Kitronik website, contain a wealth of material to aid the teacher in either case.

### ***Using the booklet***

The first few pages of this booklet contain information to aid the teacher in planning their lessons and also covers worksheet answers. The rest of the booklet is designed to be printed out as classroom handouts. In most cases all of the sheets will not be needed, hence there being no page numbers; teachers can pick and choose as they see fit.

Please feel free to print any pages of this booklet to use as student handouts in conjunction with Kitronik project kits.

### ***Support and resources***

You can also find additional resources at [www.kitronik.co.uk](http://www.kitronik.co.uk). There are component fact sheets, information on calculating resistor and capacitor values, puzzles and much more.

Kitronik provide a next day response technical assistance service via e-mail. If you have any questions regarding this kit or even suggestions for improvements, please e-mail us at:

support@kitronik.co.uk

Alternatively, phone us on 0845 8380781.



## Schemes of Work

The scheme of work included in this pack is a focused practical task covering the assembly of the kit and basic programming. Equally, feel free to use the material as you see fit to develop your own schemes.

For further lesson plans focused on programming the STOP:bit, please go to:

<https://www.kitronik.co.uk/5642-stopbit-traffic-light-for-bbc-microbit.html>

Before starting we would advise that you build a kit yourself. This will allow you to become familiar with the project and will provide a unit to demonstrate.

### *Electronics only*

Hour 1	Introduction to the kit demonstrating a built unit. Using the 'Soldering in Eight Steps' sheet, practice soldering.
Hour 2	Build the kit using the 'Build Instructions'.
Hour 3	Check the completed PCB and fault find if required using 'Checking Your PCB' and fault-finding flow chart. Program the BBC micro:bit with a basic program to test the STOP:bit.

## Answers

### *Resistor questions*

1st Band	2nd Band	Multiplier x	Value
Brown	Black	Yellow	100,000 $\Omega$
Green	Blue	Brown	560 $\Omega$
Brown	Grey	Yellow	180,000 $\Omega$
Orange	White	Black	39 $\Omega$

Value	1st Band	2nd Band	Multiplier x
180 $\Omega$	Brown	Grey	Brown
3,900 $\Omega$	Orange	White	Red
47,000 (47K) $\Omega$	Yellow	Violet	Orange
1,000,000 (1M) $\Omega$	Brown	Black	Green



## Soldering in 8 Steps

### 1 INSERT COMPONENT

Place the component into the board, making sure that it goes in the correct way around, and the part sits closely against the board. Bend the legs slightly to secure the part. Place the board so you can access the pads with a soldering iron.

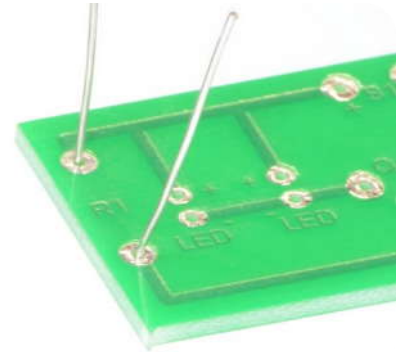

### 2 CLEAN SOLDERING IRON

Make sure the soldering iron has warmed up. If necessary use a brass soldering iron cleaner or damp sponge to clean the tip.



### 3 PICKUP IRON AND SOLDER

Pick up the Soldering Iron in one hand, and the solder in the other hand.

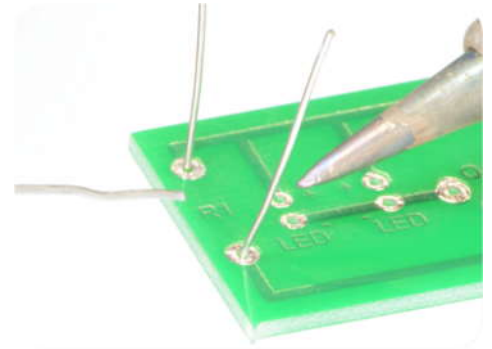

### 4 HEAT PAD

Place soldering iron tip on the pad.

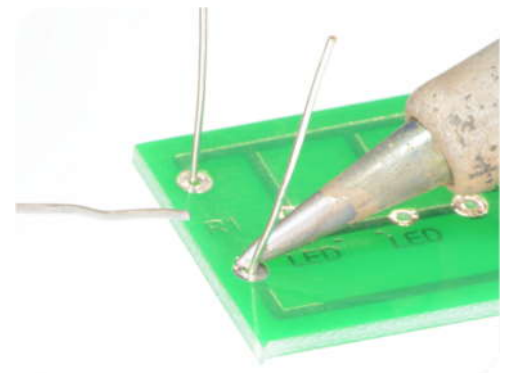

5

## APPLY SOLDER

Feed a small amount of solder into the joint. The solder should melt on the pad and flow around the component leg.

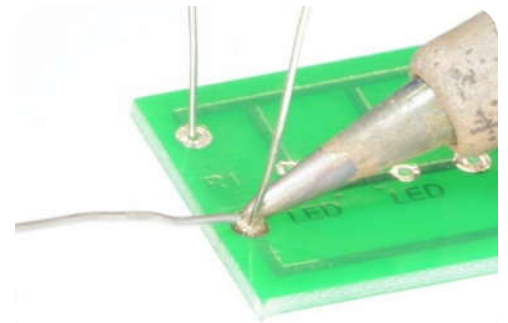

6

## STOP SOLDERING

Remove the solder, and then remove the soldering iron.

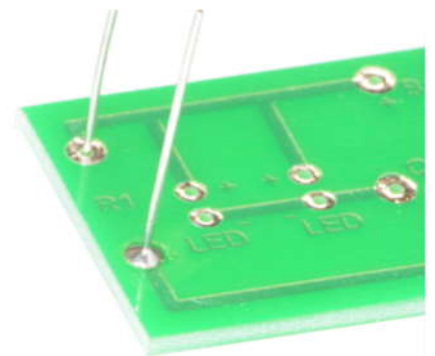

7

## TRIM EXCESS

Leave the joint to cool for a few seconds, then using a pair of cutters trim the excess component lead.

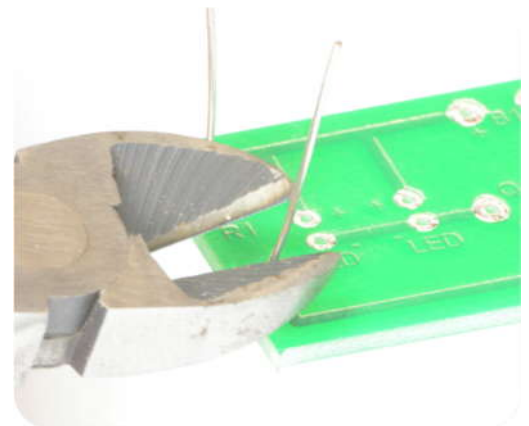

8

## REPEAT

Repeat this process for each solder joint required.

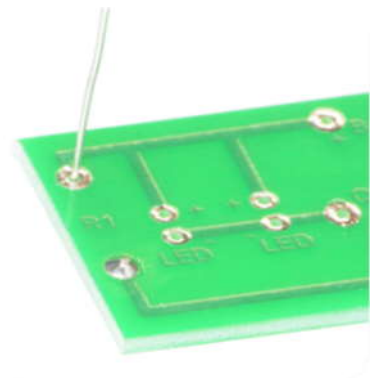

## Resistor Values

A resistor is a device that opposes the flow of electrical current. The bigger the value of a resistor, the more it opposes the current flow. The value of a resistor is given in  $\Omega$  (ohms) and is often referred to as its 'resistance'.

### Identifying resistor values

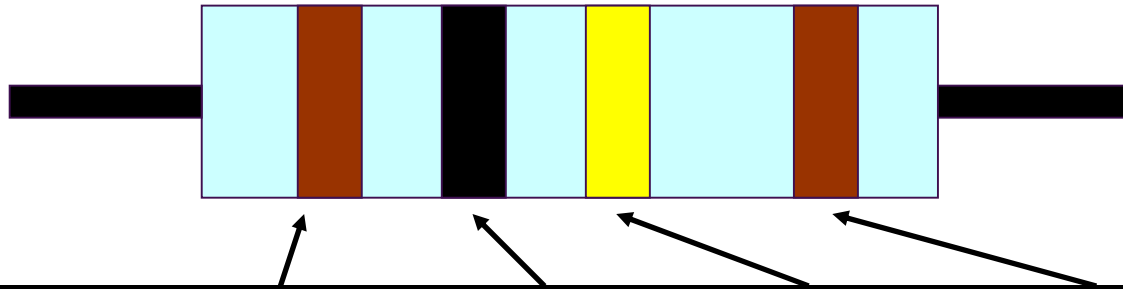

Band Colour	1st Band	2nd Band	Multiplier x	Tolerance
Silver			$\div 100$	10%
Gold			$\div 10$	5%
Black	0	0	1	
Brown	1	1	10	1%
Red	2	2	100	2%
Orange	3	3	1000	
Yellow	4	4	10,000	
Green	5	5	100,000	
Blue	6	6	1,000,000	
Violet	7	7		
Grey	8	8		
White	9	9		

Example: Band 1 = Red, Band 2 = Violet, Band 3 = Orange, Band 4 = Gold

The value of this resistor would be:

$$\begin{aligned}
 &2 \text{ (Red)} \ 7 \text{ (Violet)} \times 1,000 \text{ (Orange)} &&= 27 \times 1,000 \\
 &&&= 27,000 \text{ with a 5% tolerance (gold)} \\
 &&&= 27\text{K}\Omega
 \end{aligned}$$

#### Too many zeros?

Kilo ohms and mega ohms can be used:

$$1,000\Omega = 1\text{K}$$

$$1,000\text{K} = 1\text{M}$$

### Resistor identification task

Calculate the resistor values given by the bands shown below. The tolerance band has been ignored.

1st Band	2nd Band	Multiplier x	Value
Brown	Black	Yellow	
Green	Blue	Brown	
Brown	Grey	Yellow	
Orange	White	Black	



## Calculating resistor markings

Calculate what the colour bands would be for the following resistor values.

Value	1st Band	2nd Band	Multiplier x
180 $\Omega$			
3,900 $\Omega$			
47,000 (47K) $\Omega$			
1,000,000 (1M) $\Omega$			

## What does tolerance mean?

Resistors always have a tolerance but what does this mean? It refers to the accuracy to which it has been manufactured. For example, if you were to measure the resistance of a gold tolerance resistor you can guarantee that the value measured will be within 5% of its stated value. Tolerances are important if the accuracy of a resistors value is critical to a design's performance.

## Preferred values

There are a number of different ranges of values for resistors. Two of the most popular are the E12 and E24. They take into account the manufacturing tolerance and are chosen such that there is a minimum overlap between the upper possible value of the first value in the series and the lowest possible value of the next. Hence there are fewer values in the 10% tolerance range.

E-12 resistance tolerance ( $\pm 10\%$ )											
10	12	15	18	22	27	33	39	47	56	68	82

E-24 resistance tolerance ( $\pm 5\%$ )											
10	11	12	13	15	16	18	20	22	24	27	30
33	36	39	43	47	51	56	62	68	75	82	91





## LEDs & Current Limit Resistors

Before we look at LEDs, we first need to start with diodes. Diodes are used to control the direction of flow of electricity. In one direction they allow the current to flow through the diode, in the other direction the current is blocked.

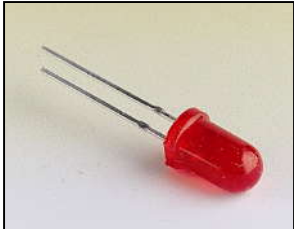

An LED is a special diode. LED stands for Light Emitting Diode. LEDs are like normal diodes, in that they only allow current to flow in one direction, however, when the current is flowing, the LED lights up.

The symbol for an LED is the same as the diode but with the addition of two arrows to show that there is light coming from the diode. As the LED only allows current to flow in one direction, it's important that we can work out which way the electricity will flow. This is indicated by a flat edge on the LED.

For an LED to light properly, the amount of current that flows through it needs to be controlled. To do this we use a current limit resistor. If we didn't use a current limit resistor the LED would be very bright for a short amount of time, before being permanently destroyed.

To work out the best resistor value we need to use Ohm's Law. This connects the voltage across a device and the current flowing through it to its resistance.

Ohm's Law tells us that the flow of current ( $I$ ) in a circuit is given by the voltage ( $V$ ) across the circuit divided by the resistance ( $R$ ) of the circuit.

$$I = \frac{V}{R}$$

Like diodes, LEDs drop some voltage across them: the 10mm LEDs used in this kit have 2.1 volts drop. Depending on the voltage drop and supply voltage, LEDs will require a different value for the current limit resistor. The STOP:bit is powered through the BBC micro:bit USB connector and on-board regulator which typically gives a 3.3V supply, so across each LED ( $V_{LED}$ ) and resistor ( $V_R$ ) must be 3.3 volts. There must be a voltage drop of 2.1 volts across the LED leaving 1.2V ( $V_{LED} + V_R = 2.2 + 1.2 = 3.3V$ ).

The LEDs normally need about 25mA to operate at full brightness. However, because they are being driven from the BBC micro:bit pins (see the 'How the Circuit Works' section), there is a current draw limit of 5mA, so this lower value needs to be used instead. Since we know that the voltage across the current limit resistor is 1.2 volts and we know that the current flowing through it is 0.005 Amps, the resistor value can be calculated.

Using Ohm's Law in a slightly rearranged format:

$$R = \frac{V}{I} = \frac{1.2}{0.005} = 240$$

Hence, we need a 220 $\Omega$  current limit resistor (it being the nearest value to the calculated value).

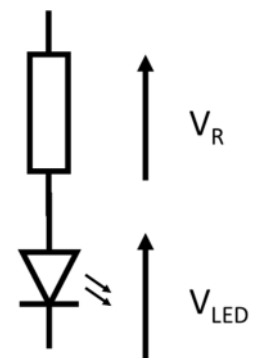

## LEDs Continued

### Packages

LEDs are available in many shapes and sizes. The 5mm round LED is the most common. The colour of the plastic lens is often the same as the actual colour of light emitted – but not always with high brightness LEDs.

### Advantages of using LEDs over bulbs

Some of the advantages of using an LED over a traditional bulb are:

Power efficiency	LEDs use less power to produce the same amount of light, which means that they are more efficient. This makes them ideal for battery power applications.
Long life	LEDs have a very long life when compared to normal light bulbs. They also fail by gradually dimming over time instead of a sharp burn out.
Low temperature	Due to the higher efficiency of LEDs, they can run much cooler than a bulb.
Hard to break	LEDs are much more resistant to mechanical shock, making them more difficult to break than a bulb.
Small	LEDs can be made very small. This allows them to be used in many applications, which would not be possible with a bulb.
Fast turn on	LEDs can light up faster than normal light bulbs, making them ideal for use in car brake lights.

### Disadvantages of using LEDs

Some of the disadvantages of using an LED over a traditional bulb are:

Cost	LEDs currently cost more for the same light output than traditional bulbs. However, this needs to be balanced against the lower running cost of LEDs due to their greater efficiency.
Drive circuit	To work in the desired manner, an LED must be supplied with the correct current. This could take the form of a series resistor or a regulated power supply.
Directional	LEDs normally produce a light that is focused in one direction, which is not ideal for some applications.

### Typical LED applications

Some applications that use LEDs are:

- Bicycle lights
- Car lights (brake and headlights)
- Traffic lights
- Indicator lights on consumer electronics
- Torches
- Backlights on flat screen TVs and displays
- Road signs
- Information displays
- Household lights
- Clocks





# ESSENTIAL INFORMATION

- BUILD INSTRUCTIONS
- CHECKING YOUR PCB & FAULT-FINDING
- EXAMPLE PROGRAMMING
- HOW THE KIT WORKS

TAKE CONTROL OF THE TRAFFIC WITH THIS

## STOP:bit for BBC MICRO:BIT KIT

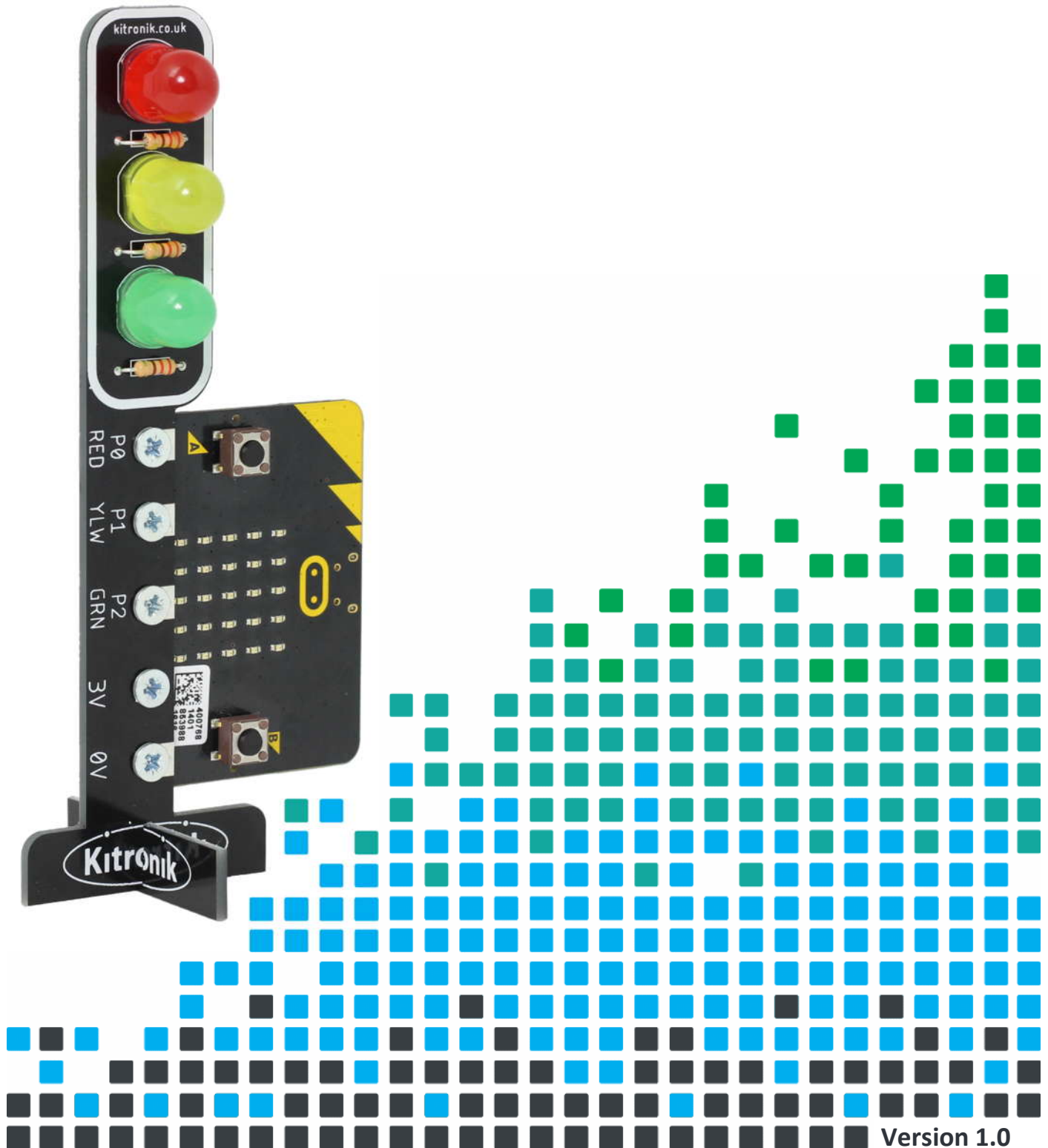

## Build Instructions

Before you start, take a look at the Printed Circuit Board (PCB). The components go in the side with the names and outlines, and the solder goes on the side with the tracks and product name (refer to 'Soldering in 8 Steps').

### 1 SOLDER THE RESISTORS

1

Start with the resistors. The text on the PCB shows where R1, R2 etc go. Ensure that you put the resistors in the right place.

PCB Ref	Value	Colour Bands
R1, R2, R3	220Ω	Red, Red, Brown



### 2 SOLDER THE LEDs

2

Place the Red LED into LED1, the Yellow LED into LED2 and the Green LED into LED3. Make sure that the short leg is placed in the – hole on each one.

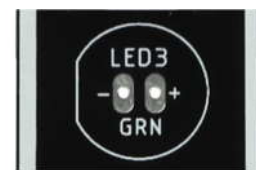
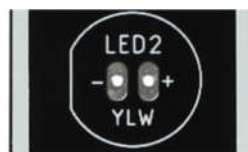

### 3 ATTACH THE BASE

3

Carefully snap off the slot-in base section from the bottom of the PCB (see images below).

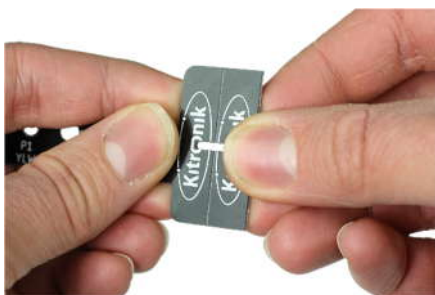

Slot the two sections together, making sure that 'Kitronik' is readable.



## Checking Your PCB

Check the following before you program and power up the unit:

### Check the bottom of the board to ensure that:

- All holes (except the large mounting holes) are filled with the lead of a component.
- All these leads are soldered.
- Pins next to each other are not soldered together.

### Check the top of the board to ensure that:

- The resistor bands on R1, R2 and R3 are Red, Red, Brown
- The Red LED is in the top position on the PCB
- The Yellow LED is in the middle position on the PCB
- The Green LED is in the bottom position on the PCB



# STOP:bit Kit Essentials

www.kitronik.co.uk/5642K



## 4 ATTACH THE BBC MICRO:BIT

Using the provided M3 nuts and bolts, attach the BBC micro:bit to the STOP:bit PCB. Make sure the BBC micro:bit is on the back of the PCB.



## 5 WRITE A MAKECODE PROGRAM FOR THE STOP:BIT

Open a web browser, go to 'makecode.microbit.org', and start a new project. Click on 'Advanced' and then 'Extensions'. Search for 'Kitronik' and add the 'kitronik-stopbit' extension (shown in the image to the right) – this will enable the STOP:bit to be controlled. Create the simple program shown here which runs through the standard traffic light pattern.

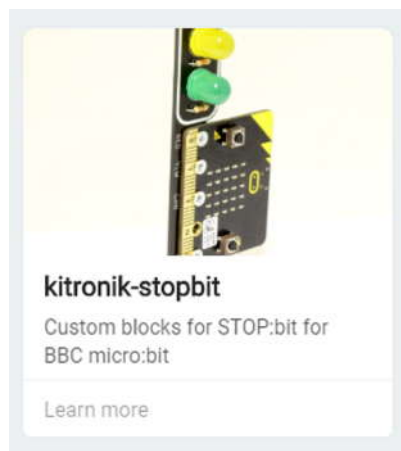

## 6 PROGRAM THE BBC MICRO:BIT

Give your MakeCode program an appropriate name and connect the BBC micro:bit to the computer using a standard micro-USB cable.

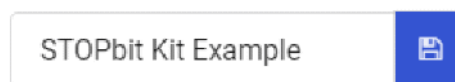

Then, depending on which web browser is being used, either save the program directly to the attached BBC micro:bit or save to the computer (the file will appear in the 'Downloads' folder). After going to the 'Downloads' folder, the program files can then be dragged and dropped into the 'MICROBIT' storage device.

Let the program run!



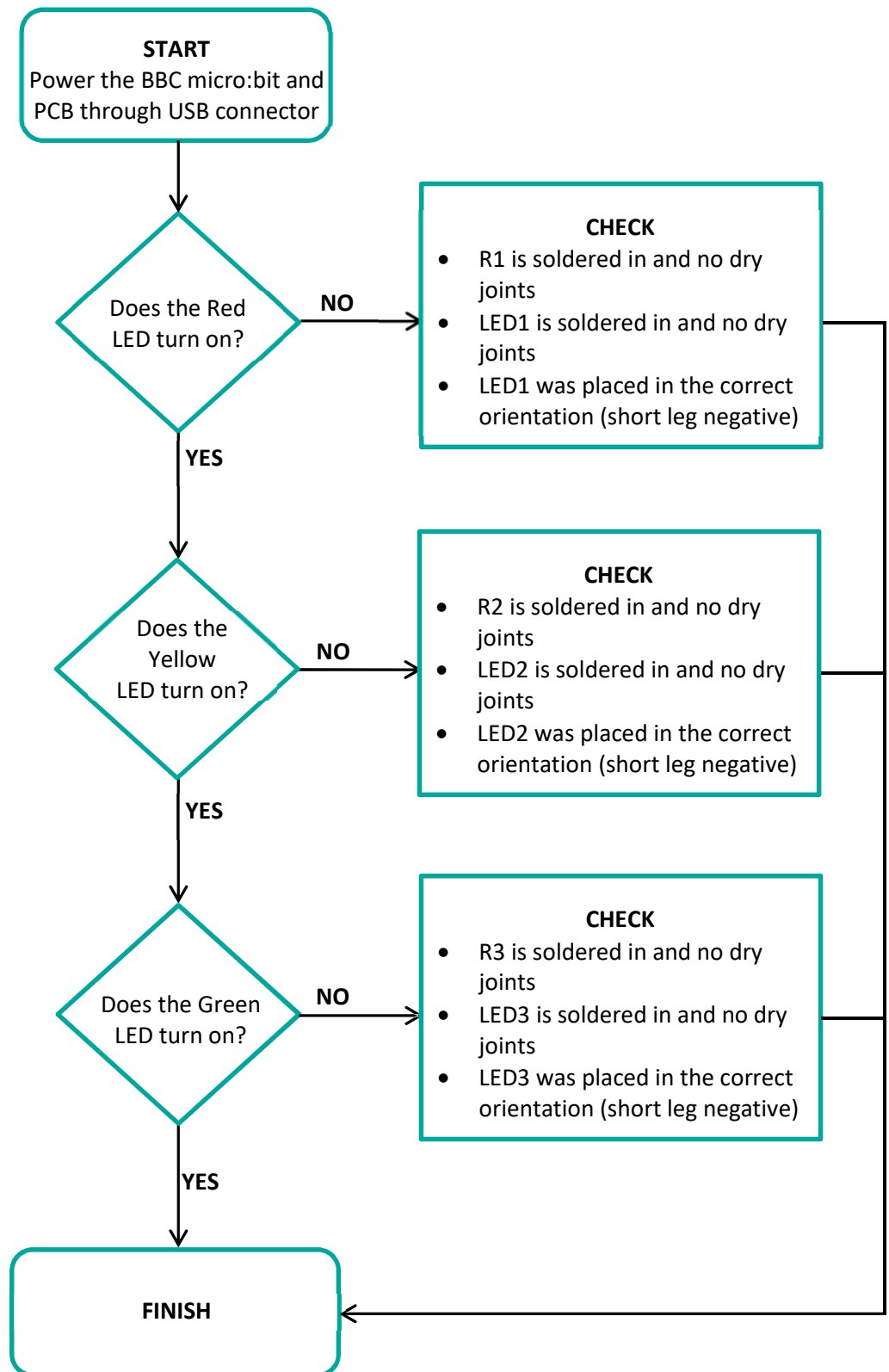

## How the Circuit Works

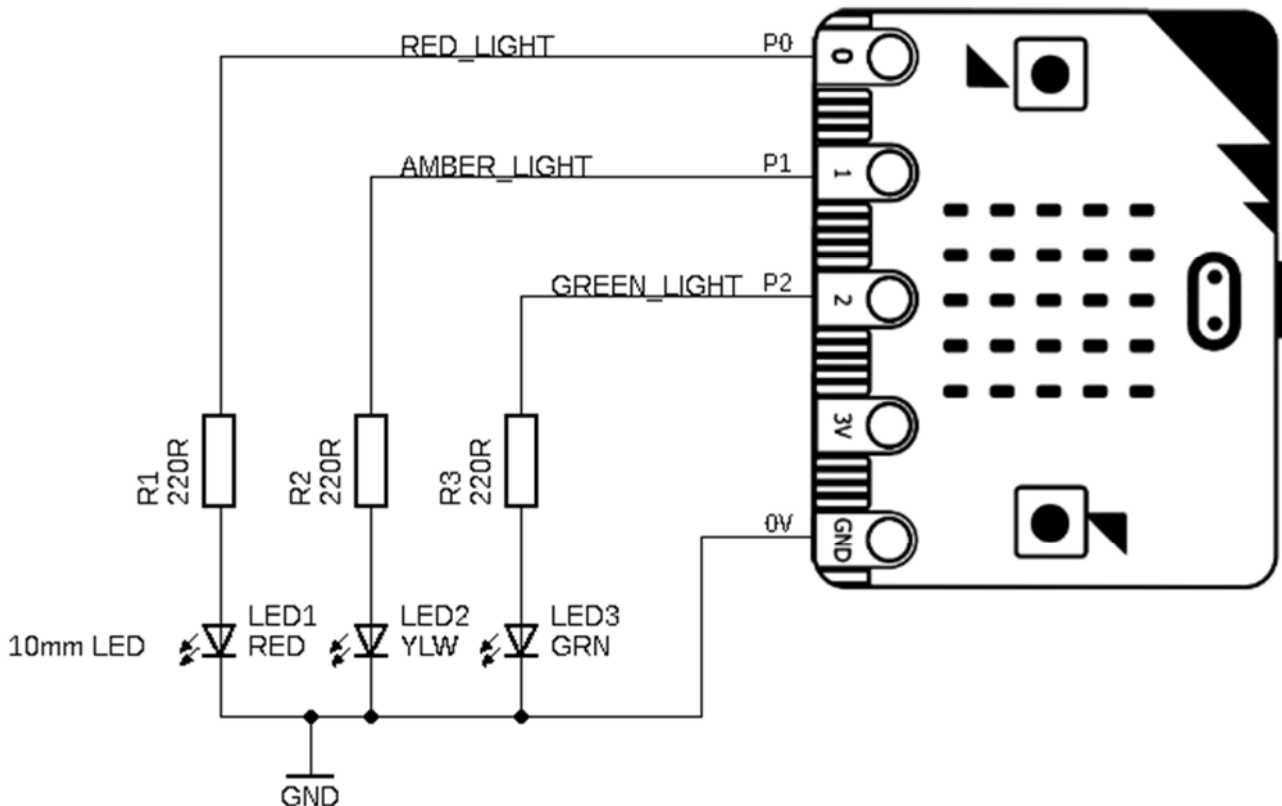

The circuit on the STOP:bit PCB itself is very simple, just three LED and current limiting resistor pairs, with each pair connected to one of the BBC micro:bit pins (Red LED1 to Pin 0, Yellow LED2 to Pin 1, Green LED3 to Pin 2). The cathodes of each LED are connected together and then connected to the BBC micro:bit 'GND' pin, completing the circuit setup. Power is provided via the USB connector on the BBC micro:bit, with an on-board voltage regulator producing the required 3.3V. By itself, this circuit will not cause the LEDs to light up, even if power is present; software needs to be written to enable control of each LED.

For the purposes of this circuit, Pins 0, 1 and 2 on the BBC micro:bit are configured as digital outputs. This means that they can be set to produce either a 'High' signal or a 'Low' signal. In digital electronics and programming, a 'High' signal is often specified by a '1', and a 'Low' signal as a '0'. This can be seen in the Microsoft MakeCode programming environment used to write software for the BBC micro:bit. Under the 'Pins' section, blocks can be found to read and write digital signals; an example is shown below:

```
on button A pressed
  digital write pin P0 to 1
  pause (ms) 1000
  digital write pin P0 to 0
```

In this simple program, pressing Button A on the BBC micro:bit will set the output of Pin 0 to be 'High' for 1000ms (1 second), and then set it back to 'Low'.

If the BBC micro:bit with this program were to be connected to the STOP:bit as shown in the circuit diagram above and Button A was pressed, this would cause the Red LED to turn on for 1 second before turning off again.

Why does this happen?





# STOP:bit Kit Essentials

[www.kitronik.co.uk/5642K](http://www.kitronik.co.uk/5642K)



Digital 'High' and 'Low' signals ('1' and '0') are just representations of what is happening electrically, in reality, these signals are actual voltages. For the BBC micro:bit, because it is running at 3.3V with a USB cable plugged in, a digital 'High' signal is a 3.3V output, and a digital 'Low' signal is a 0V output.

As has already been covered in the 'LEDs & Current Limit Resistors' section, for an LED to light up it needs to have an appropriate current running through it, and for this to happen, there needs to be a voltage drop – or voltage difference – across it. In this circuit setup, the cathode of each LED is always connected to GND (0V), so a positive voltage needs to be applied to the anode (through the current limit resistor) in order to turn it on. This happens any time Pin 0, 1 or 2 is set to 'High', there is a voltage difference across the LED, so current flows, and the LED light up. In a similar way, any time Pin 0, 1 or 2 is set to 'Low', there is no voltage difference across the LED, so no current flows, and the LED turns off.

This is what is happening in the 'kitronik-stopbit' MakeCode extension blocks, different options will set the outputs of Pins 0, 1 and 2 to be 'High' or 'Low' in different configurations, thereby switching different LEDs on and off.



## Online Information

Two sets of information can be downloaded from the product page where the kit can also be reordered from. The 'Essential Information' contains all of the information that you need to get started with the kit and the 'Teaching Resources' contains more information on soldering, components used in the kit, educational schemes of work and so on and also includes the essentials. Download from:

[www.kitronik.co.uk/5642K](http://www.kitronik.co.uk/5642K)



This kit is designed and manufactured in the UK by Kitronik

---

**Telephone:** +44 (0) 845 8380781

**Sales email:** [sales@kitronik.co.uk](mailto:sales@kitronik.co.uk)

**Tech support email:** [support@kitronik.co.uk](mailto:support@kitronik.co.uk)

**Web:** [www.kitronik.co.uk](http://www.kitronik.co.uk)



[www.kitronik.co.uk/twitter](http://www.kitronik.co.uk/twitter)



[www.kitronik.co.uk/facebook](http://www.kitronik.co.uk/facebook)



[www.kitronik.co.uk/youtube](http://www.kitronik.co.uk/youtube)



[www.kitronik.co.uk/google](http://www.kitronik.co.uk/google)

---

Every effort has been made to ensure that these notes are correct, however Kitronik accept no responsibility for issues arising from errors / omissions in the notes.

© Kitronik Ltd - Any unauthorised copying / duplication of this booklet or part thereof for purposes except for use with Kitronik project kits is not allowed without Kitronik's prior consent.

---

