

Description

A precision linear resonant inductive position sensor with a measuring range of 265mm. Works with CambridgeIC's Central Tracking Unit (CTU) chips to provide high-quality position data to a host device.

The sensor has two sets of sensor coils: one for taking fine incremental measurements at high accuracy and resolution and another for coarse, absolute measurements. The sensor is Type 6, Subtype 12 (Type "6.12").

The sensor is connected to a CambridgeIC CTU chip, which combines the information from both sets of coils to deliver an absolute, high accuracy and high resolution output to a host system.

Features

- Full absolute linear sensing
- 265mm Measuring Range
- 6-layer PCB process
- Target is sensed from FRONT or REAR of sensor
- Compact sensor coils

Performance, Free Space

- Linearity Error < 0.05% at 0.5mm...1.5mm Gap
- Noise Free Resolution > 13.5 bits up to 1.5mm Gap
- Up to 0.5mm Y Misalignment

Applications

- Inside extruded aluminium section
- Actuator position feedback
- Optical and magnetic scale replacement

Product identification	
Part no.	Description
013-0043	Assembled sensor, 10mm wide
010-0111	Sensor Blueprint
013-1020	11mm E-Core Target
013-1023	11mm E-Core Target, -3% frequency
013-6001	6-way sensor connecting cable

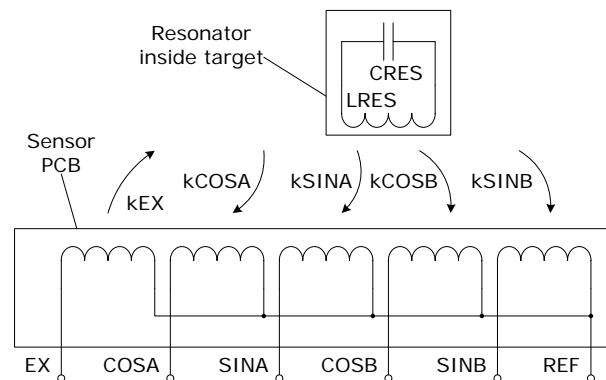

Figure 1 equivalent circuit

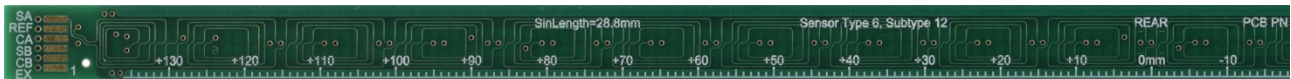

Figure 2 Sensor PCB Assembly 013-0043, REAR, connector end

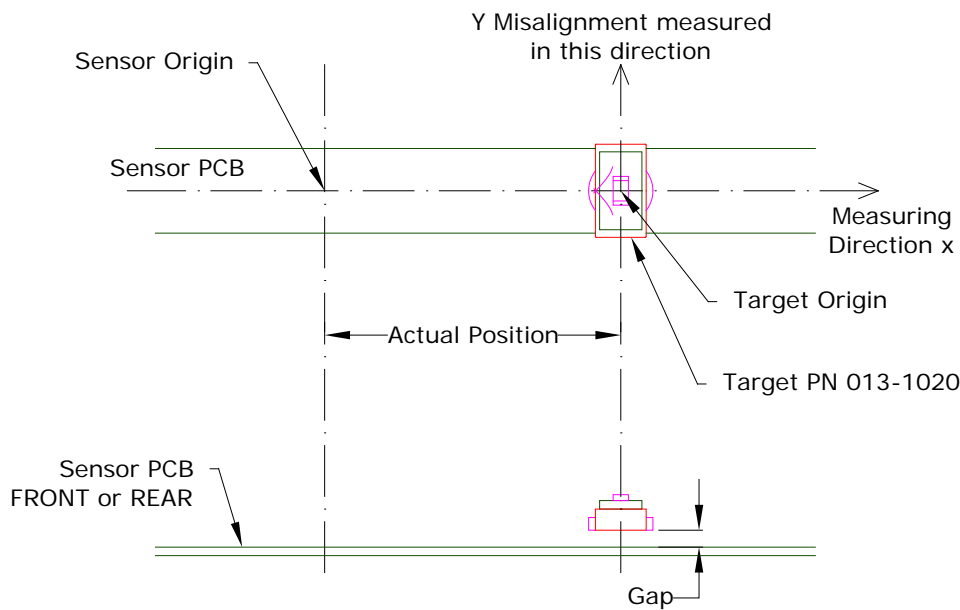

Figure 3 Alignment of sensor PCB assembly 013-0043 with target 013-1020

1 Assembled Sensor 013-0043 Mechanical Design

The 265mm Type 6.12 Linear Sensor is available as an assembled PCB including connector. An image of its REAR side is shown in Figure 2. Figure 4 is a mechanical drawing. The sensor PCB's FRONT is shown in plan view to the top left, with side views to the right and underneath.

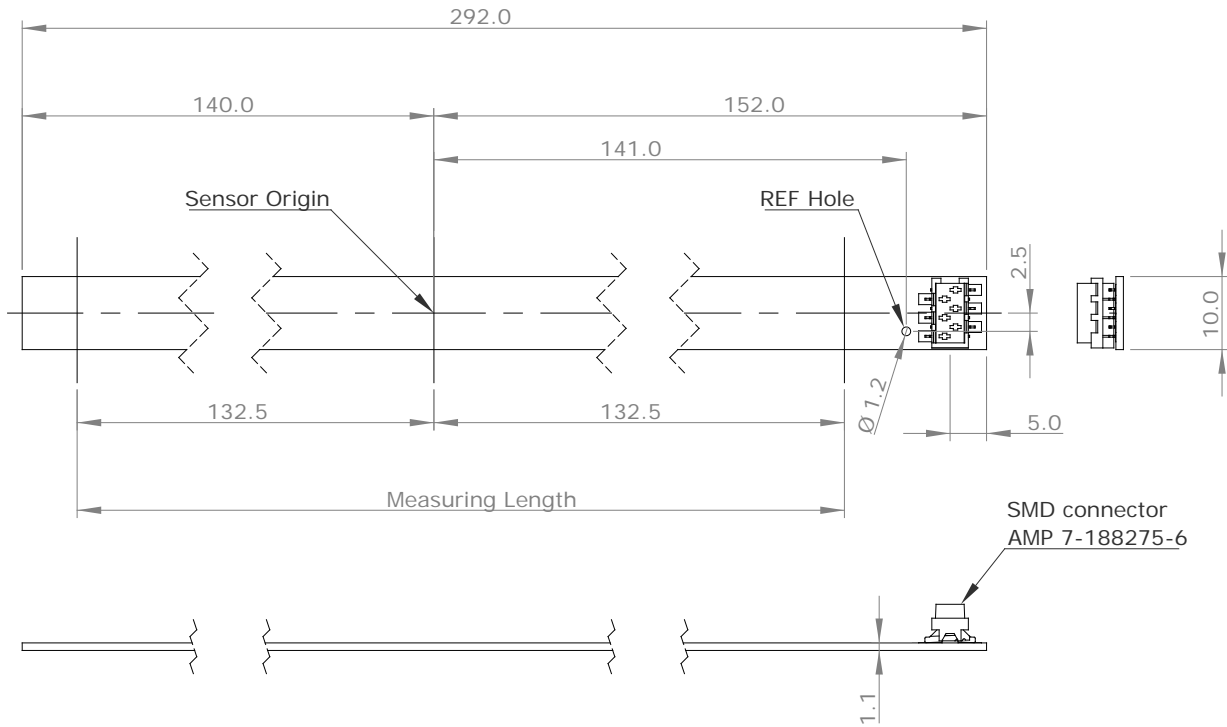

Figure 4 Mechanical drawing, sensor PCB assembly 013-0043

The FRONT of the sensor PCB is fitted with an SM connector AMP 7-188275-6. The REAR includes a single row of 1.25mm pitch connecting pads that do not have a connector fitted. The pinout for both is shown in Table 1.

Table 1 Sensor PCB electrical connections

Pin no	Signal name
1	EX
2	CB
3	SB
4	CA
5	REF
6	SA

The 265mm Type 6.12 Linear Sensor works with the 11mm E-Core Target, for example part number 013-1020. Their relative alignment is illustrated in Figure 3. The target may be adjacent either the FRONT or REAR surface of the sensor PCB.

The sensor measures Actual Position relative to the Sensor Origin. The nominal location of the Sensor Origin is 141.0mm to the left of the Ref Hole marked on Figure 4, and centered on the sensor PCB's 10mm width. The resulting Offset Error is on the order of ± 0.25 mm (section 3.4).

2 Principle of Operation

2.1 Electronic Interrogation

The 265mm Type 6.12 Linear Sensor is connected to a CambridgeIC CTU chip (e.g. the CAM204) and its associated circuitry. To take a position measurement the CTU chip first generates a few cycles of AC current in the EX coil matching the resonant frequency of the resonator. This current forces the resonator to resonate. When the excitation current is removed the resonator continues to resonate, with its “envelope” decaying exponentially as shown in Figure 5. This decaying signal generates EMFs in the 4 sensor coils. The CTU chip detects the relative amplitude of the decaying resonator signal in each coil. It uses the amplitude information to determine position, as described below in section 2.2.

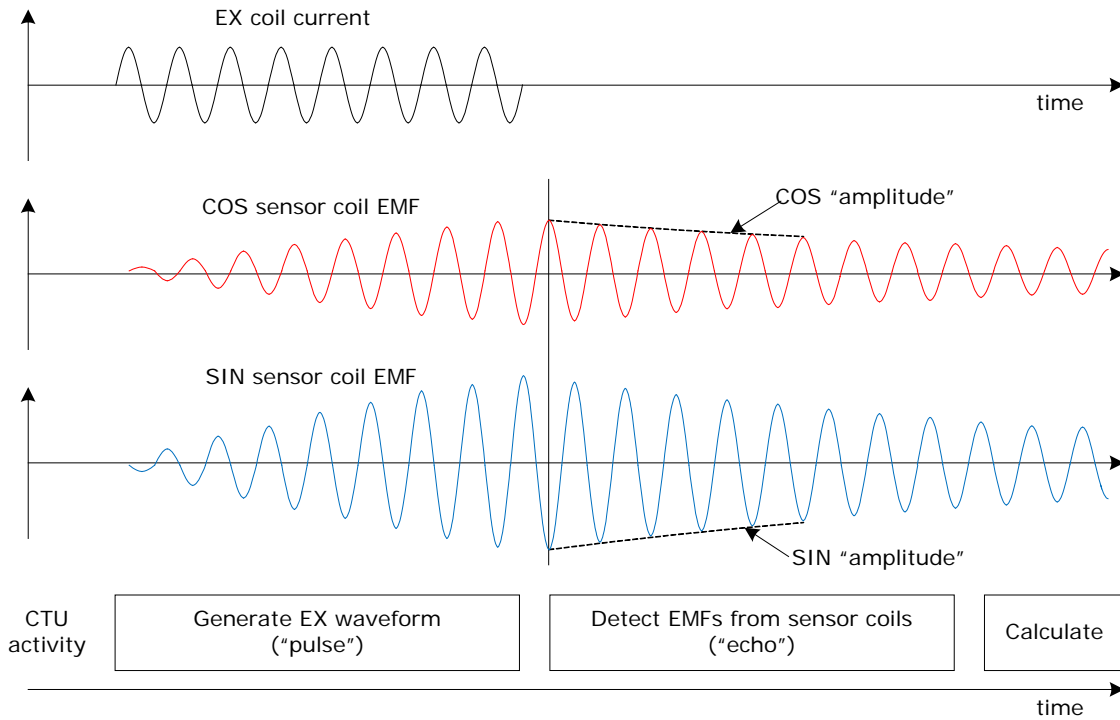

Figure 5 Electronic interrogation process

2.2 Sensor Coils and Position Calculation

Section 2.1 described how the CambridgeIC CTU chip detects the relative amplitude of the signals induced by the resonator in the sensor's 4 sensor coils. These measured amplitudes are proportional to the coupling factors between the resonator and each of the 4 sensor coils, kCOSA, kSINA, kCOSB, kSINB. This subsection describes how these coupling factors change with position, and the calculation the CTU chip performs to determine this position.

Figure 6 illustrates the right hand half of each of the 5 coils in the sensor individually, one above the other. In reality, they are all overlain. They are simplified for clarity, including showing single coil turns where there are several. The left hand half of each coil is omitted for clarity, and is the same as the right hand half rotated about the Sensor Origin, with coil connections replaced by shorts.

The EX coil is rectangular and extends slightly beyond the measuring range, so that its coupling to the resonator is largely uniform. This means the resonator signal at the end of the excitation process is approximately uniform along the sensor's measuring range.

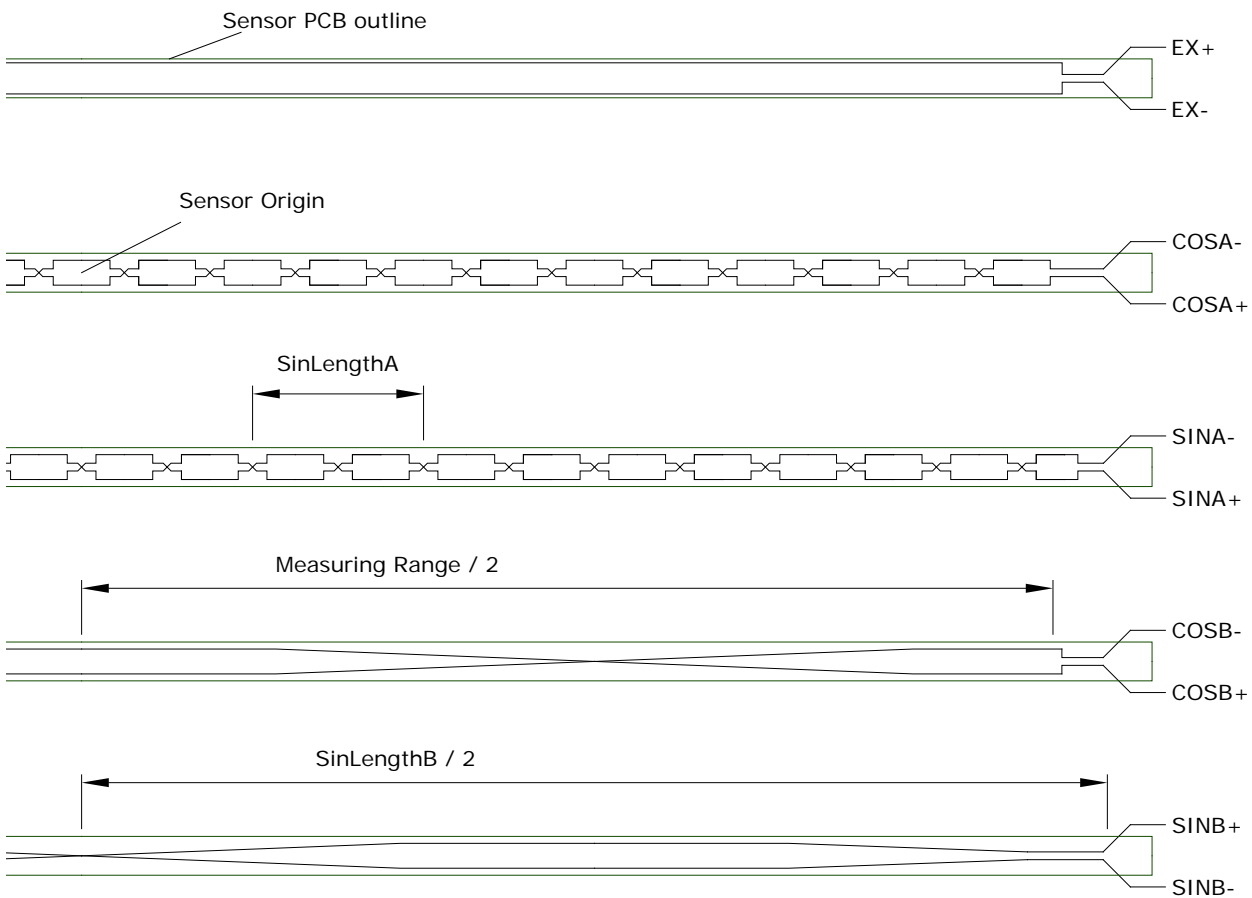

Figure 6 Coil designs, right hand half, simplified for clarity

The COSA and SINA coils are fine sensor coils. The coupling factor between resonator and fine coils varies sinusoidally with position. There are 12 repeating periods along the measuring range, as illustrated in Figure 7. Their sinusoidal period is denoted SinLengthA. The kCOSA and kSINA coupling factors are in phase quadrature. The CTU chip measures these coupling factors, and performs a 4-quadrant inverse tangent calculation on them to determine *Fine Position*. This calculation is fully ratiometric, so that changes in absolute signal levels due to variations in power supply voltage, temperature and so on do not affect the measurement.

The Fine Position measurement is a precise measure of position. However it is ambiguous: there are several locations along the sensor that have the same Fine Position due to the repeating nature of the fine sensor coil pattern.

To resolve this ambiguity, the CTU chip also takes readings from the coarse sensor coils COSB and SINB. These yield the Coarse Position measurement. These are also sinusoidally patterned but have a longer period, SinLengthB. The coarse coils also have fewer turns in the actual design, which together with the longer period yield much lower measurement precision. However this precision is still more than adequate to resolve the Fine Position ambiguity.

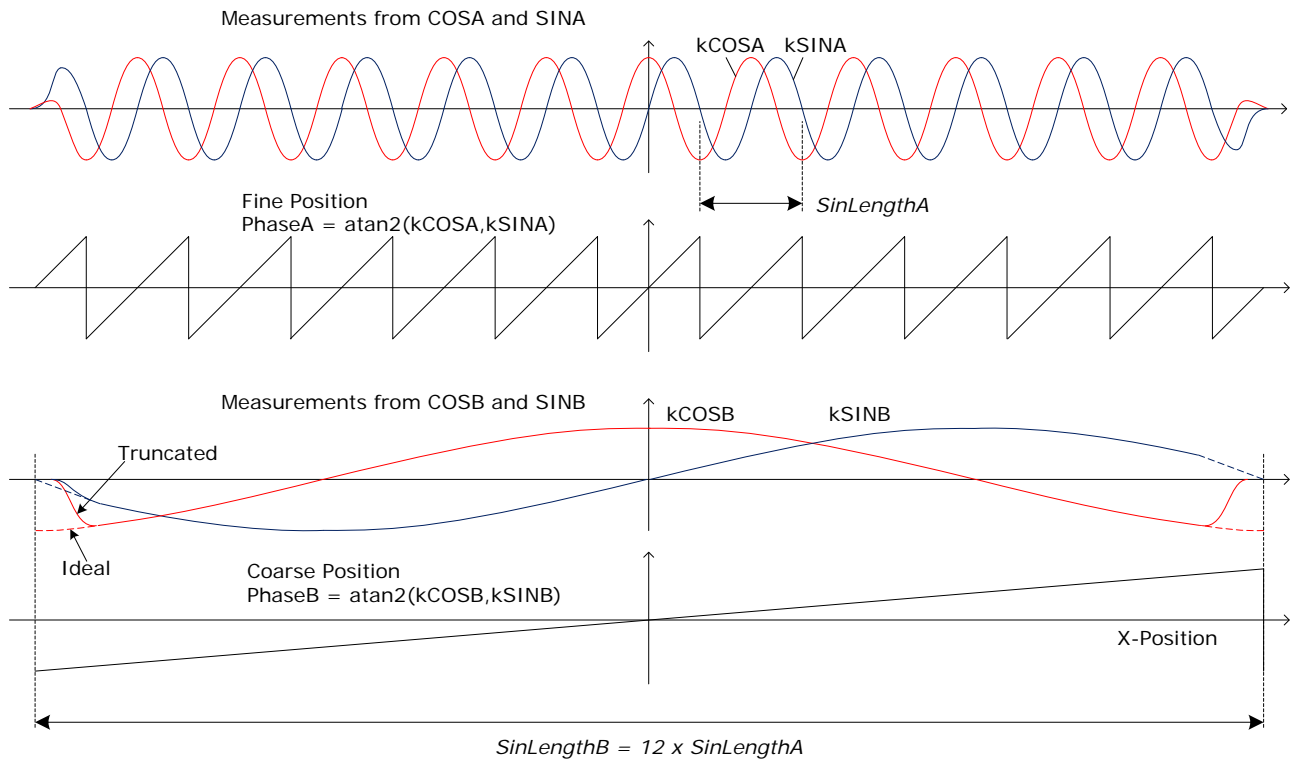

Figure 7 Sensor Coil coupling factors

The CTU chip measures both Fine and Coarse Position, and combines both measurements to deliver a full absolute value of reported position to the host. This has the precision and accuracy of the Fine sensor coils, and is absolute like the coarse sensor coils.

The Fine Pitch parameter SinLengthA, also denoted just *SinLength* defines how reported position is scaled into physical units.

The Coarse Pitch parameter SinLengthB is 12 times SinLengthA, and the number 12 corresponds to the sensor's Subtype. Both the sensor's Type (6) and Subtype (12) must be communicated to the CTU chip for correct operation. Please refer to the datasheet for the appropriate part.

3 Definitions

3.1 Coordinate System

Figure 3 illustrates the coordinate system for the sensor, with the X-Axis running along the measuring direction and the Y-Axis perpendicular and also in the plane of the sensor PCB.

The Gap dimension is the distance between the resonator and the sensor PCB. This is measured between the nearest faces of the target and sensor PCB as shown in Figure 3.

The Target Origin should run centrally along the sensor as shown. Y Misalignment is defined as the distance between the Target Origin and the sensor's centre line in the Y-Axis direction.

3.2 Transfer Function and Performance Metrics

The sensor is connected to a CTU chip which reports position as a 32-bit signed integer, here denoted *CtuReportedPositionI32*. The CTU chip also reports a VALID flag to indicate when the resonator is in range. These vary with Actual Position as illustrated in Figure 8.

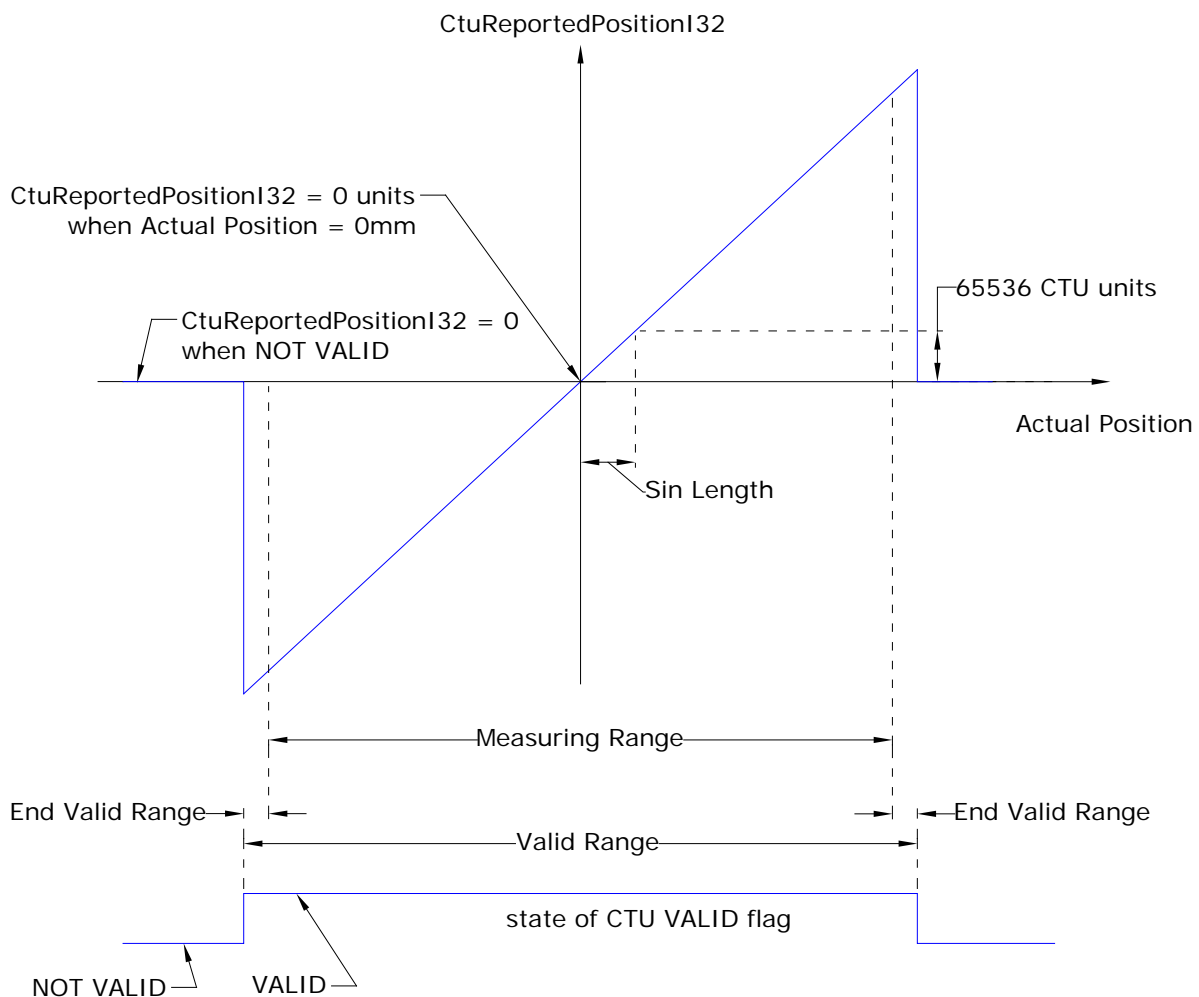

Figure 8 Transfer function (not to scale)

The VALID Range is the distance over which the CTU reports VALID. When VALID, *CtuReportedPositionI32* varies linearly with Actual Position as shown. The slope of the transfer function is defined by the SinLength parameter (SinLengthA). The Measuring Range is the distance over which full performance is quoted. The Valid Range exceeds the Measuring Range by an amount End Valid Range each side, so that the sensor's output can be VALID throughout the Measuring Range.

The CTU chip's position output may be converted to reported position in physical units using:

$$\text{Reported Position} = \frac{\text{CtuReportedPositionI32}}{65536} \times \text{SinLength}$$

Equation 1

This figure is nominally equal to the Actual Position defined in section 3.1. The figures differ due to random noise, Linearity Error and Offset Error:

$$\text{Reported Position} - \text{Actual Position} = \text{Random Noise} + \text{Linearity Error} + \text{Offset Error}$$

Equation 2

3.3 Random Noise and Resolution

Random noise is inherent in any analog measurement. The random noise present in the CTU's reported measurements can be considered Gaussian (*well behaved noise*). There are two general measures of Random Noise, Peak to Peak Noise and Standard Deviation. Defining Peak to Peak Noise such that it encompasses 99.9% of samples (100% is physically impossible due to the statistical nature of noise) yields the following relationship:

$$\text{Peak to Peak Noise} = 6.6 \times \text{Standard Deviation}$$

Equation 3

Another common measure of noise used in encoders is Noise Free Resolution, which is related to Peak to Peak Noise as follows:

$$\text{Noise Free Resolution} = \log_2 \frac{\text{Measuring Range}}{\text{Peak to Peak Noise}}$$

Equation 4

Noise Free Resolution can be improved by averaging raw samples from a CTU, or applying some other digital filter to the samples. Averaging 2^N samples increases Noise Free Resolution by $N/2$ bits. So averaging 4 samples ($N=2$) improves Noise Free Resolution by 1 bit, and averaging 16 ($N=4$) samples improves Noise Free Resolution by 2 bits. Measurements of Linearity Error and Offset Error are separated from Random Noise by averaging in this way.

The CAM502 CTU chip has an on-chip digital filter that can be configured to improve resolution at the expense of group delay. Please refer to its datasheet for the available settings and their effects.

3.4 Linearity Error and Offset Error

Linearity Error is the deviation of the transfer function from a best fit straight line. Strictly, the figures quoted in this datasheet are based on a best fit straight line whose slope and offset are adjusted to minimise the maximum magnitude of Linearity Error, so that the maximum positive and negative linearity departures have equal magnitude.

The slope of the best fit straight line is the SinLength parameter quoted below. Its value can also change due to a small stretch error inherent in the PCB manufacturing process.

There are two main contributions to Offset Error: one from the sensor and one from the target.

The target's contribution to Offset Error is the mechanical tolerance with which the Target Origin can be located relative to appropriate alignment features, and therefore depends on how these features are designed.

The sensor's contribution to Offset Error is mainly due to the PCB manufacturing process, in particular linear misregistration of copper layers relative to chosen registration features, and sensor PCB stretch error between the reference feature and Sensor Origin.

3.5 Proximity of Metal to Sensor and Target

The 265mm Type 6.12 Linear Sensor may be used in close proximity to aluminium. Performance is quoted for a small number of simple metal configurations illustrated in Figure 9. Figure 9(a) defines *Distance to Aluminium Sheet Behind Sensor PCB*. Figure 9(b) defines *Distance to Aluminium Sheet Behind Target*. Figure 9(c) defines *Distance to Aluminium Sheet to Side*. Figures are presented for the case where the aluminium is thicker than 0.2mm. Thinner material including foil is not recommended because it has higher resistance, and therefore tends to absorb the system's AC magnetic fields rather than "reflecting" them in a more lossless way.

(a) Aluminium sheet behind sensor PCB

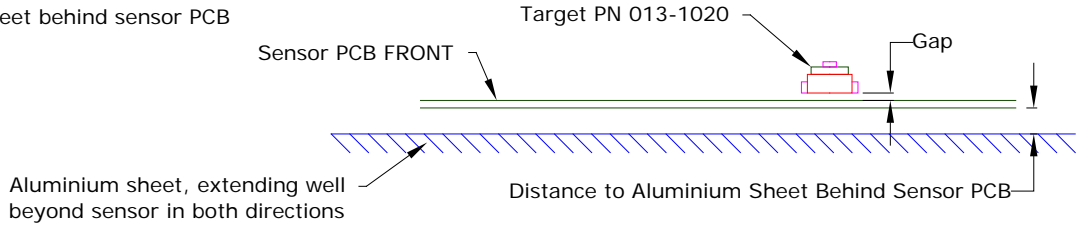

(b) Aluminium sheet behind Target

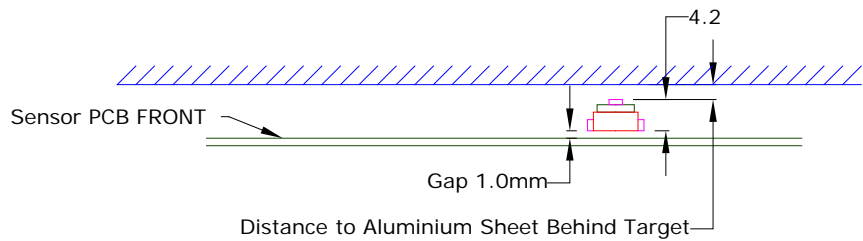

(c) Aluminium sheet to the side

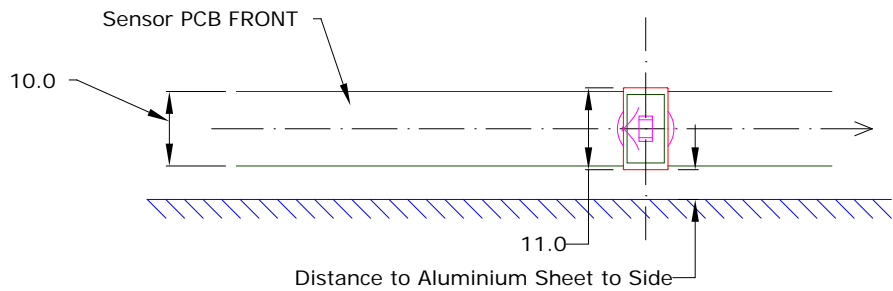

Figure 9 Definitions for aluminium proximity

4 Performance

Figures below are representative of assembled sensor PCBs 013-0043 and sensor PCBs built to Sensor Blueprint 010-0111. Measurements are taken with a typical target PN 013-1020, and Type 6 CAM204 CTU Circuitry (see CAM204 datasheet, grade A components), at room temperature. Sensors are mounted flush against a flat surface for test purposes.

Measurements are presented as a function of Gap, which is defined in Figure 3. Unless otherwise stated, values presented below are worst case across Y misalignment of up to 0.5mm.

Measurements in this section are taken with an aluminium sheet behind the sensor PCB, as in Figure 9(a), unless otherwise stated. The *Distance to Aluminium Sheet Behind Sensor PCB* is defined in Figure 9(a). The absolute minimum value is 1.2mm, while measurements at 5.2mm are hardly influenced by the aluminium at all and are also representative of free space operation.

4.1 End Valid Range

End Valid Range is the distance each side of the Measuring Range over which the CTU chip's output remains VALID, as shown in Figure 8. It is a function of Gap and Distance to Aluminium Sheet Behind Sensor PCB as illustrated in Figure 10 below.

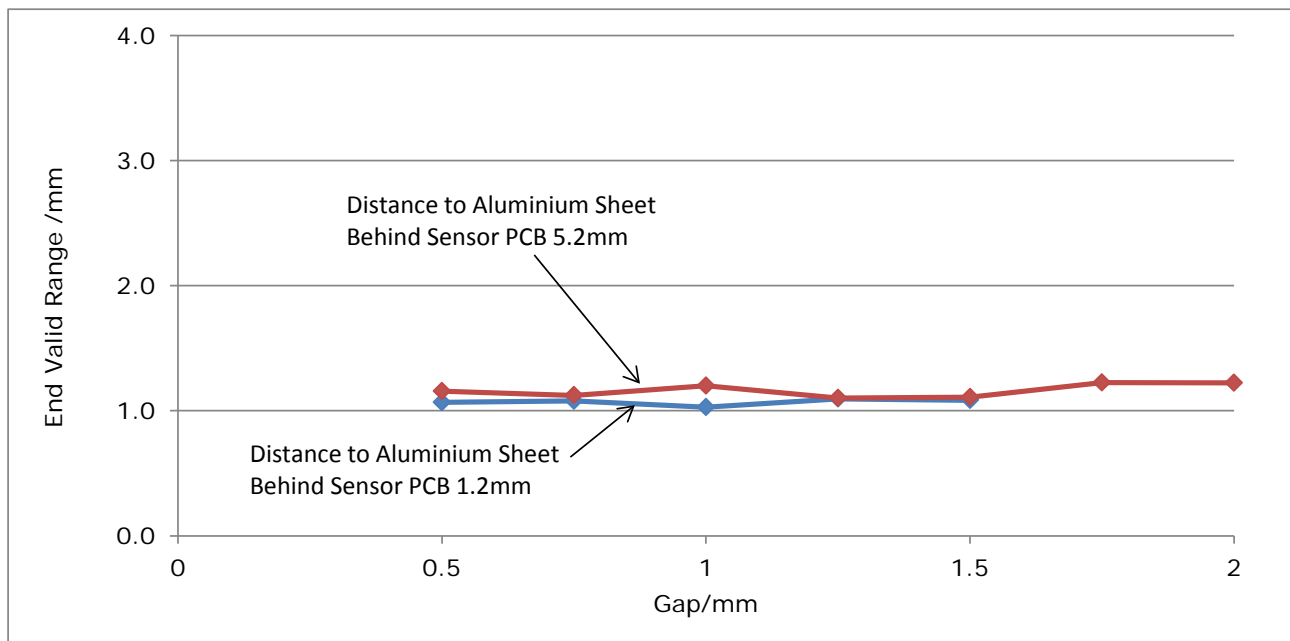

Figure 10 End Valid Range as a function of Gap

4.2 Linearity Error

Linearity Error is defined in section 3.4. Its value is also a function of Gap and the Distance to Aluminium Sheet Behind Sensor PCB, as shown in Figure 11.

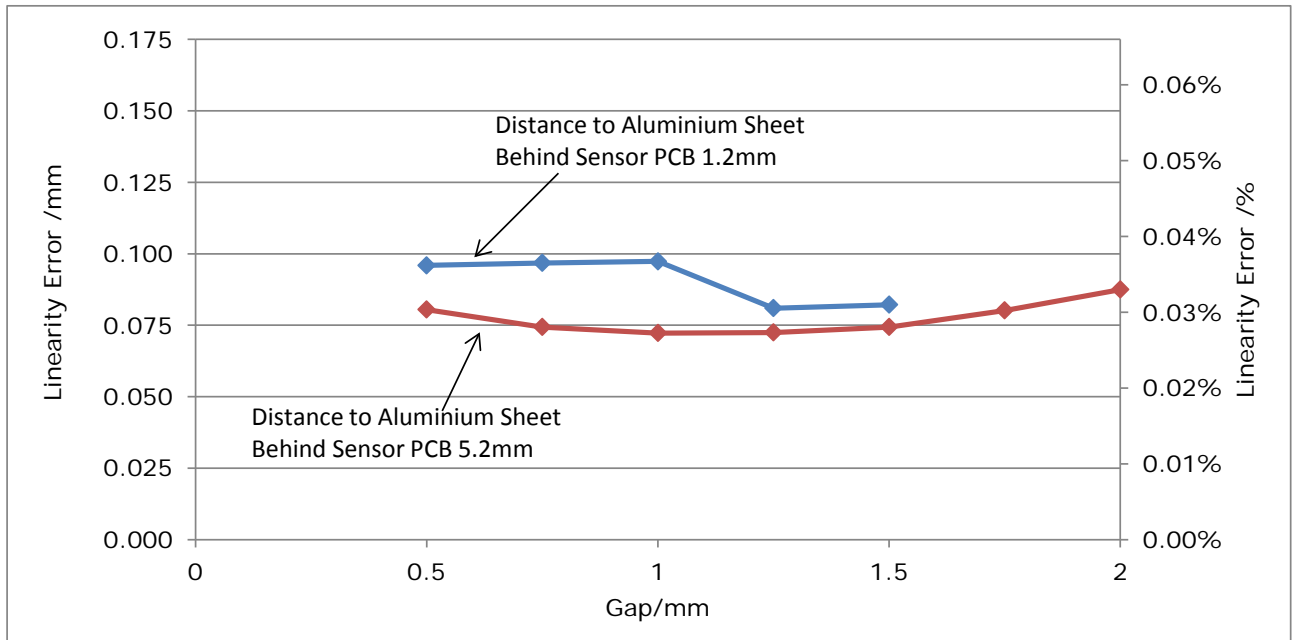

Figure 11 Linearity Error as a function of Gap

4.3 SinLength Value

The SinLength parameter is the sinusoidal pitch of the fine sensor coil coupling, SinLengthA, as illustrated in Figure 7. Its value is mainly defined by the layout of the fine sensor coils, and is 28.80mm by design. However the exact best fit value for use in Equation 1 is also a weak function of Gap and the Distance to Aluminium Sheet Behind Sensor PCB, as illustrated in Figure 12.

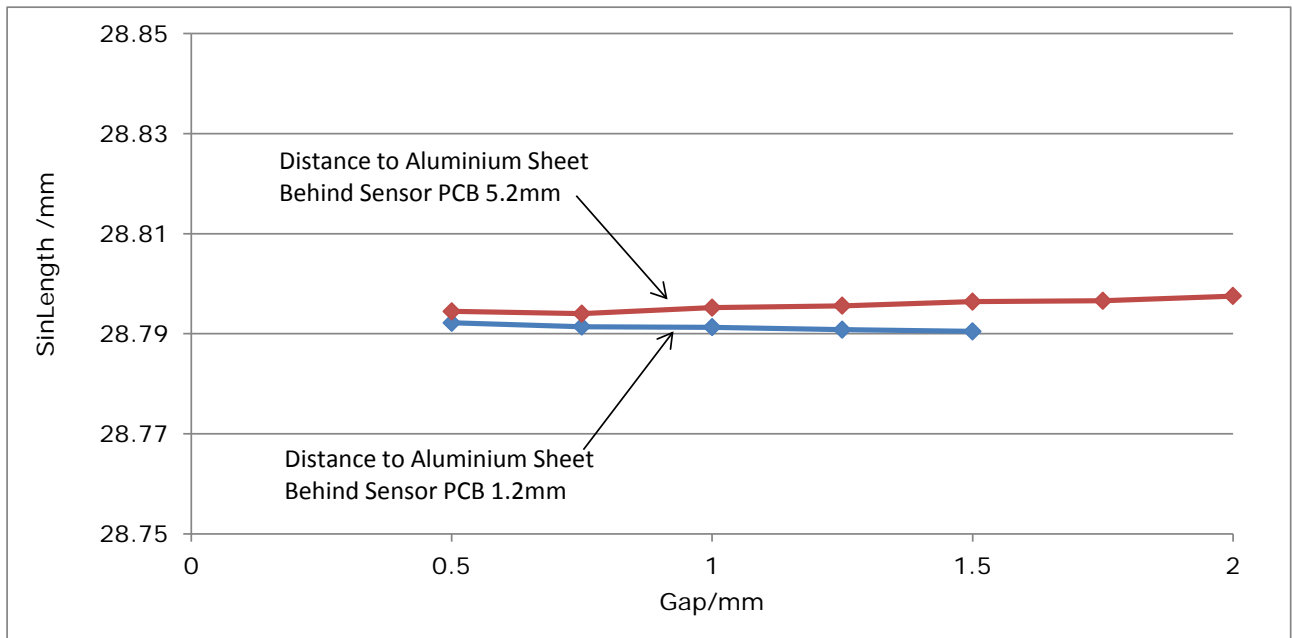

Figure 12 SinLength value as a function of Gap

The exact SinLength value is also subject to $\pm 0.1\%$ error due to stretch error in the PCB fabrication process. Thermal expansion also affects the length of the PCB and hence the SinLength value. Its magnitude is $\sim 13\text{ppm}/^\circ\text{C}$, assuming FR4 PCB material that is allowed to expand.

4.4 Amplitude

In addition to reporting position, the CTU chip also reports Amplitude. Amplitude is a useful measure of system health, and reduces with Gap as shown in Figure 13. Amplitude also reduces with the presence of nearby metal, and sensor installations should be checked to ensure any reduction is not excessive. See also section 4.6.

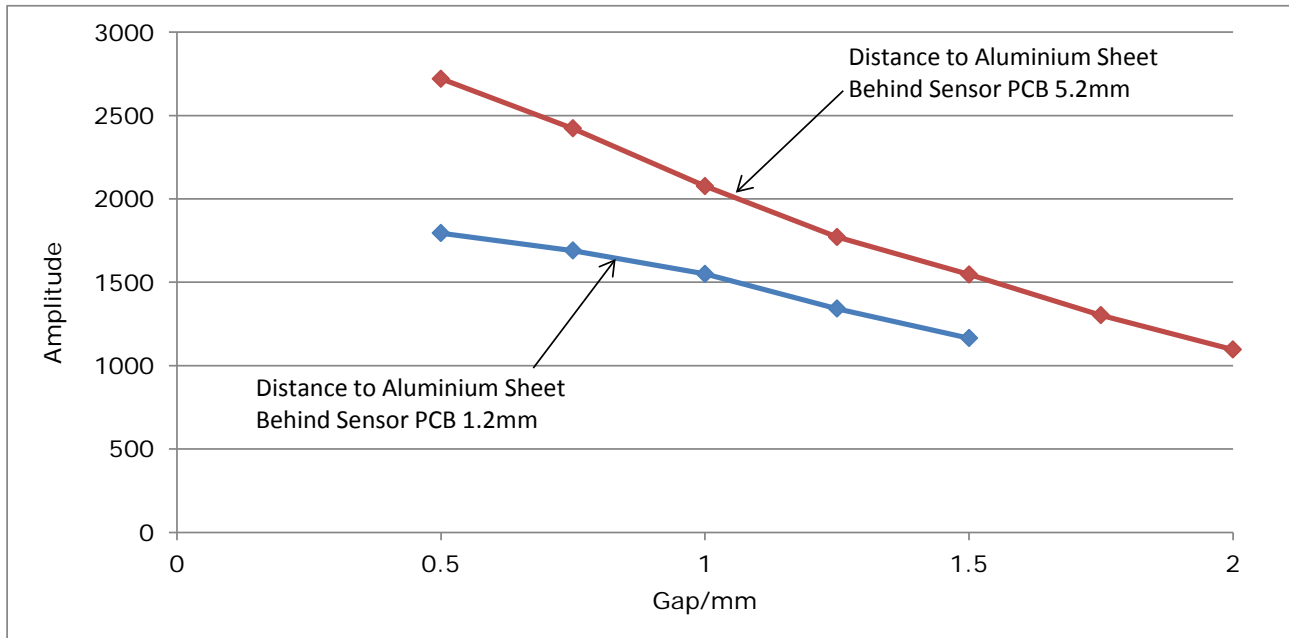

Figure 13 Minimum Reported Amplitude as a function of Gap, free space

4.5 Noise Free Resolution

Noise Free Resolution is defined in section 3.3. It is a function of the signal level detected by the CTU chip. It therefore reduces with Gap and metal proximity in a similar way to Reported Amplitude as illustrated in Figure 14.

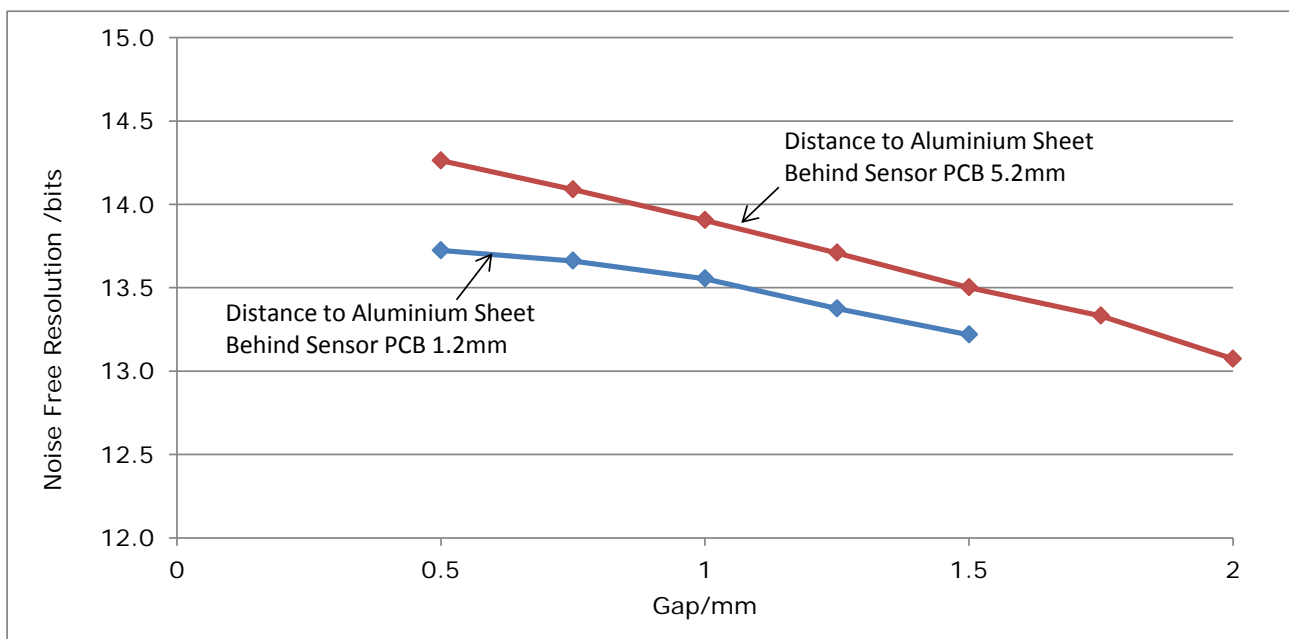

Figure 14 Noise Free Resolution as a function of Gap, CAM204 CTU chip, free space

Quoted Noise Free Resolution is based on single measurements from a CTU chip. The host may average (or otherwise digitally filter) measurements to yield a higher resolution than shown above, at the expense of greater latency.

4.6 Effect of Aluminium on Amplitude

Amplitude is reported by the CTU chip connected to the sensor. It is an important indication of system health, and in general reduces when metal is nearby. Measurements in this section are for a Gap between sensor PCB and target of 1mm, and taken with the CAM204 CTU chip.

Figure 15 illustrates how Amplitude changes with Distance to Aluminium Sheet Behind sensor PCB, as defined in Figure 9(a).

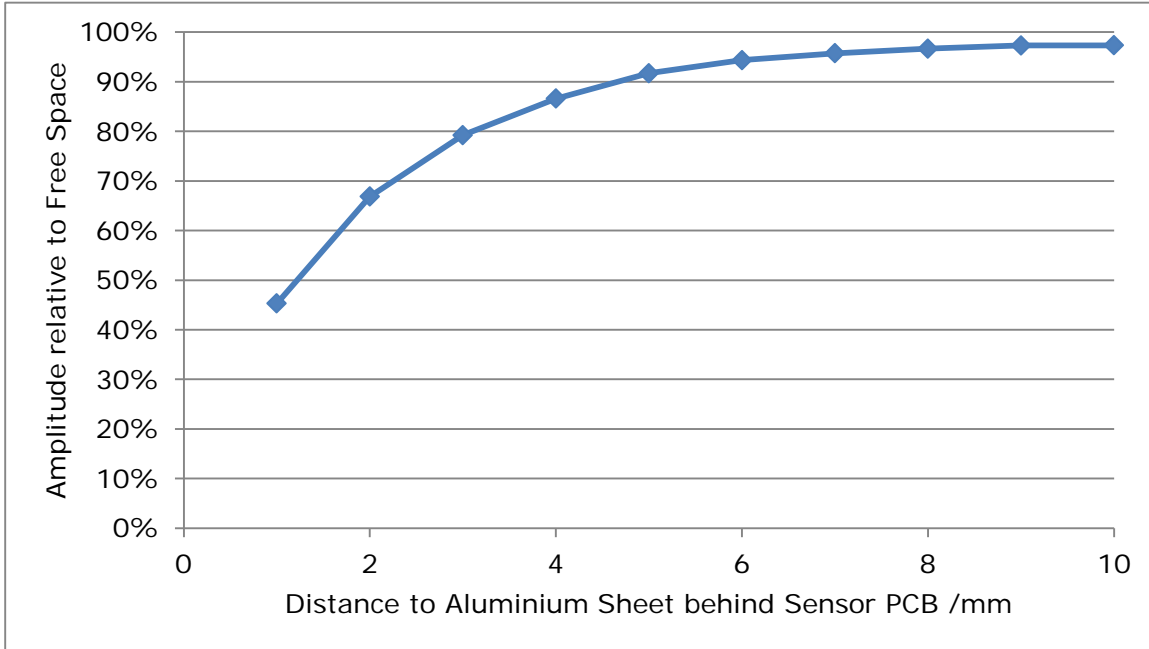

Figure 15 Amplitude reduction due to aluminium behind sensor PCB

Figure 16 illustrates how Amplitude changes with Distance to Aluminium Sheet Behind Target, as defined in Figure 9(b).

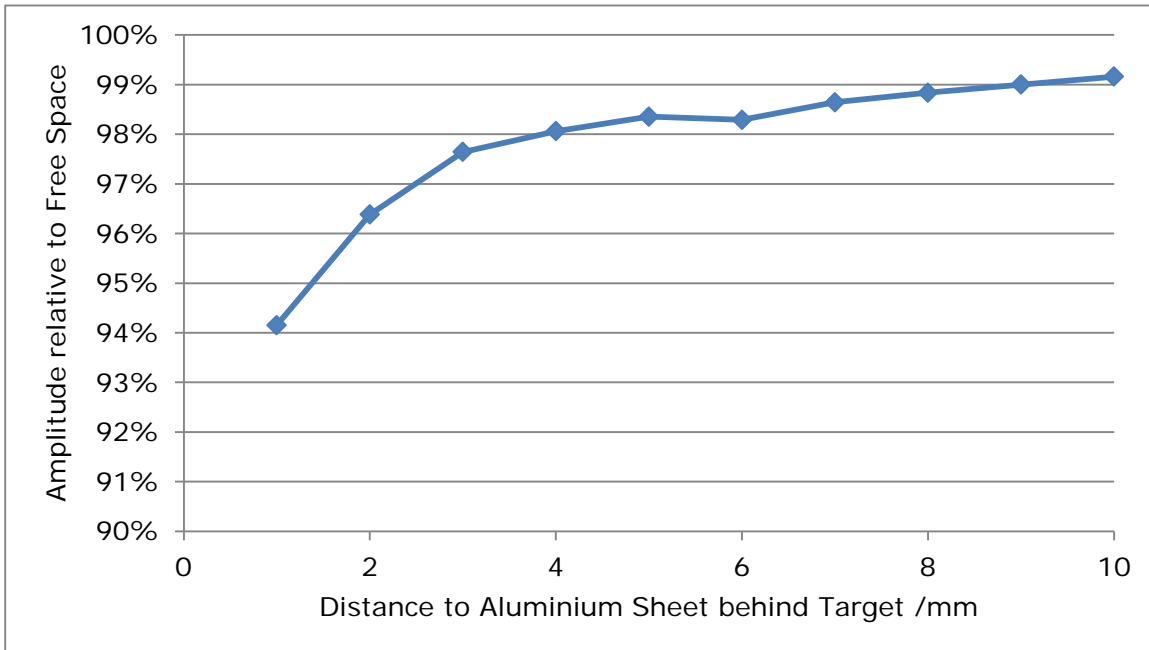

Figure 16 Amplitude reduction due to aluminium behind Target

Figure 17 illustrates how Amplitude changes with Distance to Aluminium Sheet to Side, as defined in Figure 9(c).

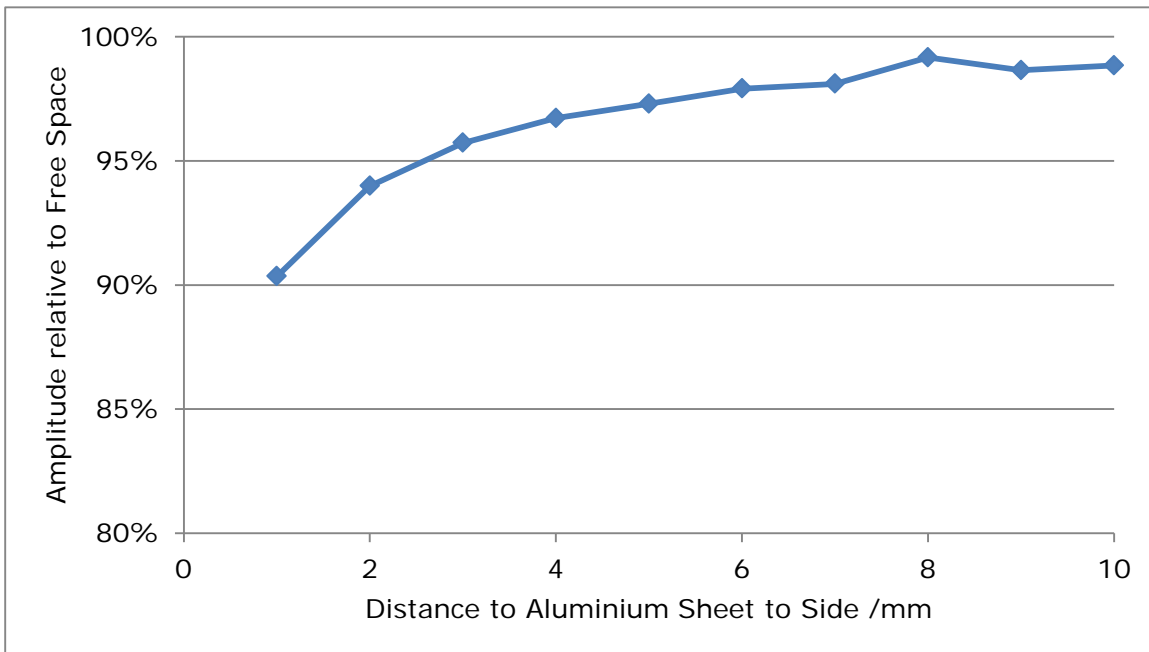

Figure 17 Amplitude reduction due to aluminium to the side

The most significant effect of a reduction in Amplitude is to increase the level of random noise present in the position data returned by the system, or equivalently to reduce the noise free resolution. If Amplitude is reduced to 50% of its free space value then position noise will increase by approximately a factor of 2, and hence Noise Free Resolution will reduce by 1 bit.

Care must also be taken to ensure that the presence of metal does not reduce Amplitude below the minimum detectable level specified for the CTU chip to be used across temperature, typically ~1000.

The effect of aluminium present on two or more sides of the sensor and target may be estimated by combining the effects for each side the aluminium is present. For example, aluminium 2mm behind the sensor PCB reduces Amplitude to 67% of its free space value, and aluminium 3mm from the side of the target to 96%. The combination of aluminium 2mm behind the sensor and 3mm to each side of the target is then approximately $67\% \times 96\% \times 96\% = 62\%$ Amplitude relative to free space.

For a more values, or where the metal environment is uneven, it is important to check with a physical system.

4.7 Effect of Aluminium on Resonator Frequency

The CTU chip connected to the sensor reports the frequency difference between the resonator and the CTU chip's centre frequency. Changes in relative frequency make little difference to system function when the frequency difference is inside the CTU's tuning range. However the CTU chip may not report VALID if the frequency is outside this range, so it is important to ensure the resonator frequency will remain within this range across all targets and CTU ICs, and across temperature. The target's datasheet includes manufacturing and temperature tolerances, and this section describes the expected effect of nearby aluminium. Measurements in this section are at a Gap of 1mm between sensor PCB and target.

The target's resonant frequency will increase as aluminium approaches. Figure 18 illustrates the increase with aluminium behind the sensor PCB, Figure 19 with aluminium behind the target and Figure 20 with aluminium to the side.

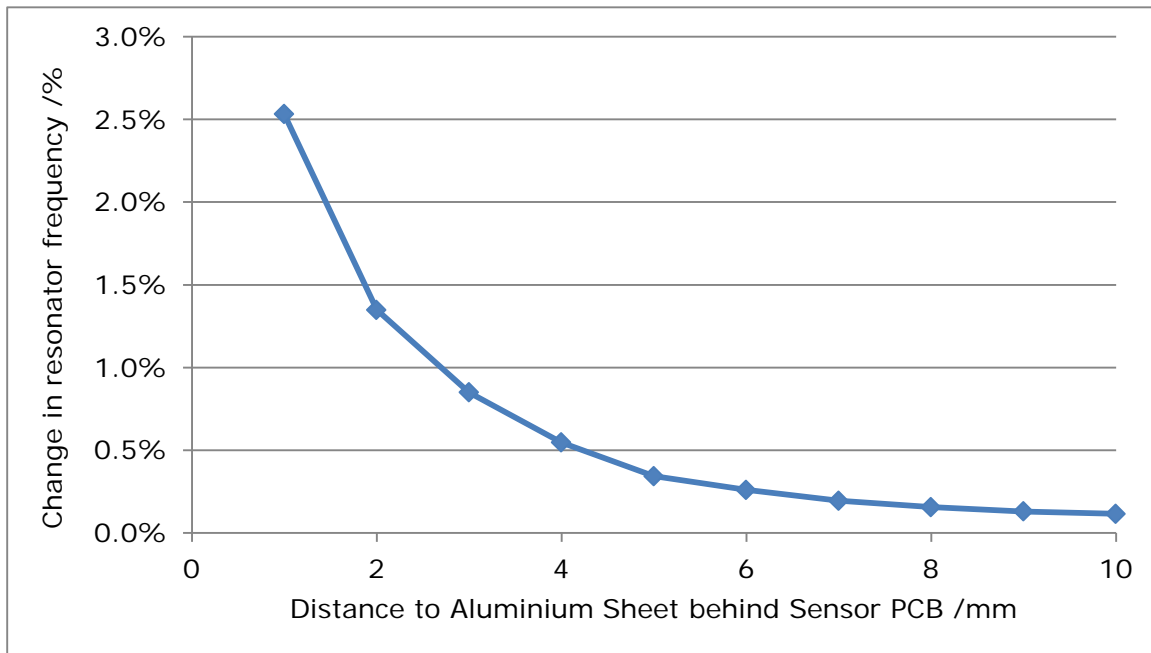

Figure 18 Resonator frequency change due to aluminium behind sensor PCB

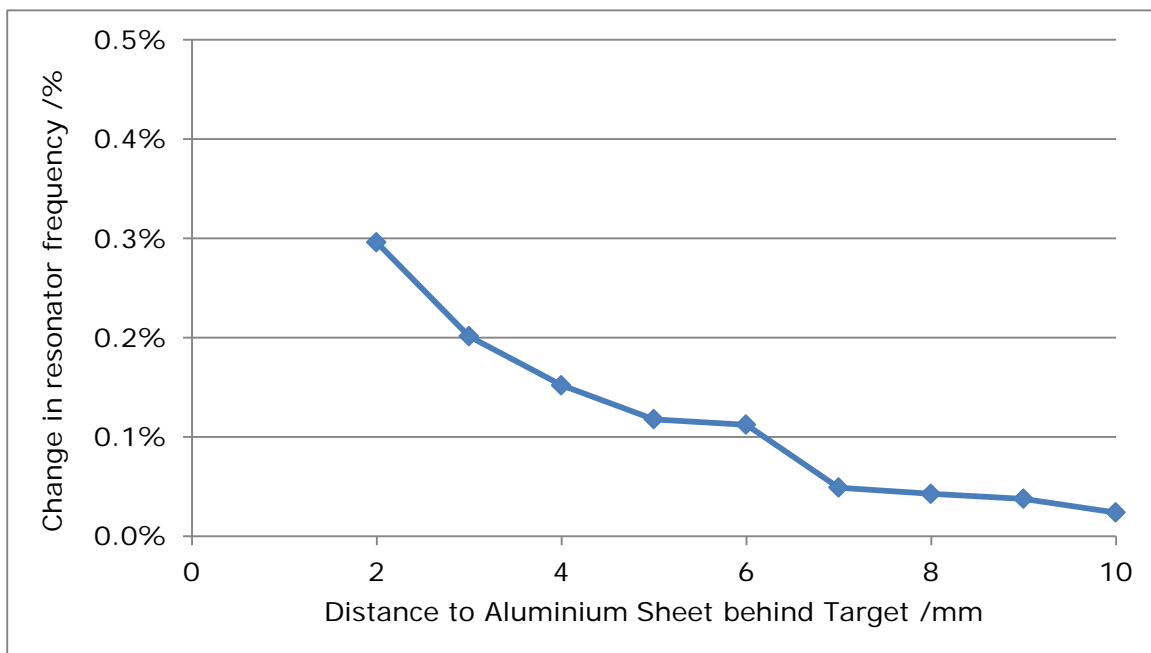

Figure 19 Resonator frequency change due to aluminium behind Target

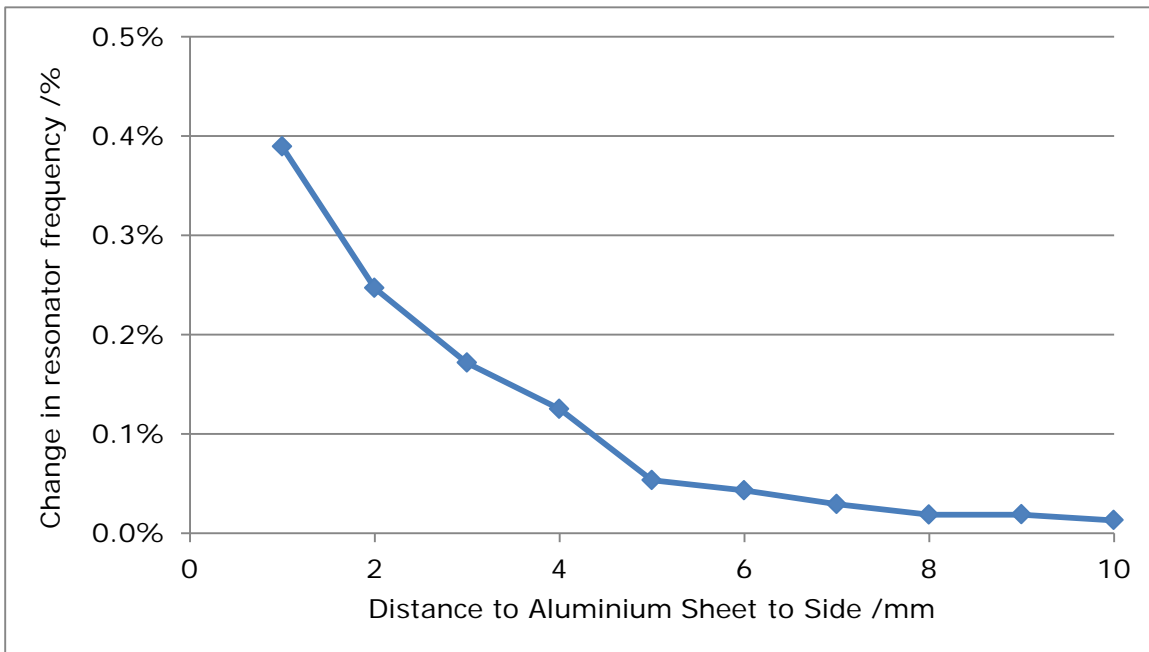

Figure 20 Resonator frequency change due to aluminium to the side

The effect of aluminium present on two or more sides of the sensor and target may be estimated by combining the effects for each side the aluminium is present. For example, aluminium 2mm behind the sensor PCB increases frequency by 1.3% relative to free space, and aluminium 3mm to the side of the target increases frequency by 0.17%. The combination of aluminium 2mm behind the sensor and 3mm to each side of the target is then approximately $1.3\% + 2 \times 0.17\% = 1.8\%$ frequency increase.

For more accurate values, or where the metal environment is uneven, it is important to check with a physical system.

Different variants of the 11mm E-Core target are available to suit different metal environments. For example the part 013-1020 has a nominal free space resonant frequency of 187.5kHz, matching the CAM204 chip's nominal frequency. It is therefore suited to operation in free space, and situations where nearby metal has a small effect. Part 013-1023 has a nominal free space resonant frequency of 187.5kHz minus 3%, which makes it suitable when the metal environment increases frequency by about 3% relative to free space.

Please refer to the white paper "Resonant Frequency Centering" for more details on the effect of metal on resonators, how to measure and analyse its impact and modifying the design to suit.

5 Sensor Blueprint 010-0111

5.1 Purpose

A Sensor Blueprint is data defining the pattern of conductors for building the sensor onto a PCB. A customer may build their own sensors for use with CambridgeIC’s CTU chips, either as stand-alone sensors or combined with their own circuitry.

5.2 Fabrication Technology

Sensor Blueprint 010-0111 is fabricated on a 6-layer PCB. Recommended copper thickness is shown in Table 2.

Table 2

Copper thickness	oz	µm
Minimum	0.8	28
Recommended	1	35

5.3 PCB Design Parameters

Table 3

PCB Design Rules	Minimum values used	
	mm	inches
Track width	0.2	0.0079
Gap between tracks	0.19	0.0075
Via land outer diameter	0.8	0.031
Drill hole diameter	0.4	0.016

5.4 PCB Integration

Figure 21 illustrates the extent of the copper pattern required to build the sensor on a PCB. The shaded area is the sensor itself. The coil pattern may be rotated or flipped to fit a customer’s assembly, in which case the position reported by the CTU will be transformed accordingly.

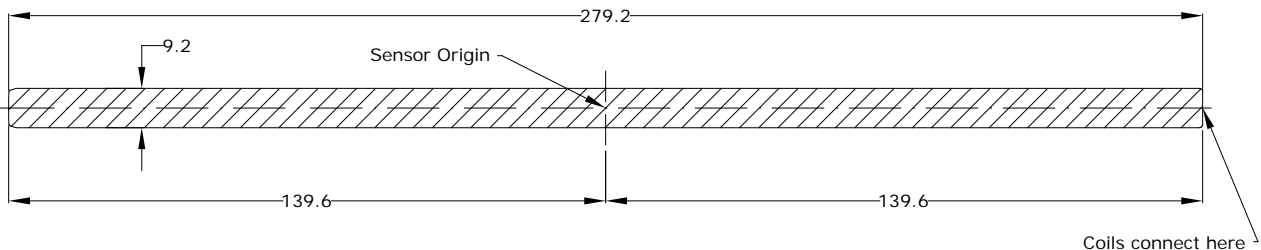

Figure 21 Copper extent, Sensor Blueprint 010-0111

When integrating with other electronic circuitry, a keep-out of 3mm is recommended all around the sensor’s conductors. Copper traces surrounding the sensor must not include a complete loop, otherwise these may appear as a “shorted turn” to the sensor’s excitation coil and Amplitude may be reduced dramatically.

5.5 Data Format

The Sensor Blueprint is supplied as Gerber data in RS-274-X format with the following settings: imperial, 2.4 precision and leading zero suppression. Coordinates are relative to the Sensor Axis.

5.6 Trace Connections

There are 5 pairs of tracks (EX, COSA, SINA, COSB, SINB and their respective VREF connections), which should be connected to the respective CTU circuit connections with the minimum practical trace lengths.

Please refer to the CTU datasheet for recommendations on track design for connecting sensors to CTU circuitry.

6 Environmental

Assembled sensor part number 013-0038 conforms to the following environmental specifications:

Item		Comments
Minimum operating temperature	-40°C	Sensor limited by the connector
Maximum operating temperature	85°C	
Maximum operating humidity	95%	Non-condensing

The maximum operating temperature of the sensor PCB may be increased if a customer manufactures their own sensor PCB to CambridgeIC's design, and uses an alternative, higher temperature, connecting method.

7 RoHS Compliance

CambridgeIC certifies, to the best of its knowledge and understanding that part number 013-0038 is in compliance with EU RoHS, China RoHS and Korea RoHS.

8 Document History

Revision	Date	Comments
0001	7 February 2017	First draft

9 Contact Information

Cambridge Integrated Circuits Ltd
21 Sedley Taylor Road
Cambridge
CB2 8PW
UK

Tel: +44 (0) 1223 413500

info@cambridgeic.com

10 Legal

This document is © 2017 Cambridge Integrated Circuits Ltd (CambridgeIC). It may not be reproduced, in whole or part, either in written or electronic form, without the consent of CambridgeIC. This document is subject to change without notice. It, and the products described in it ("Products"), are supplied on an as-is basis, and no warranty as to their suitability for any particular purpose is either made or implied. CambridgeIC will not accept any claim for damages as a result of the failure of the Products. The Products are not intended for use in medical applications, or other applications where their failure might reasonably be expected to result in personal injury. The publication of this document does not imply any license to use patents or other intellectual property rights.

The design of the sensor, comprising each of the patterned copper layers, drill locations, silk screens, assembly layers and board outline are protected by copyright.