

# Micro Dot pHAT (PIM182)

Raspberry Pi GPIO

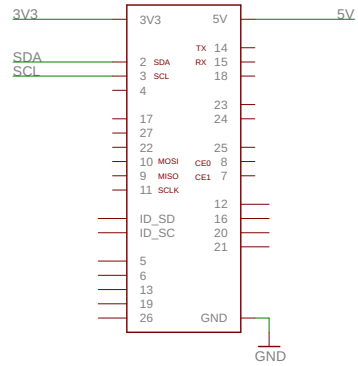

Matrix Driver  
Address: 0x63

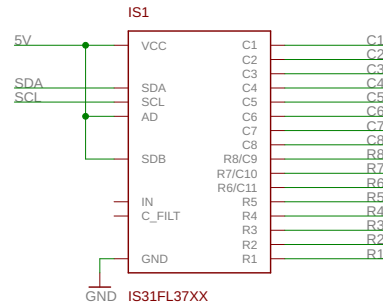

LTP-305(G/HR) Landings

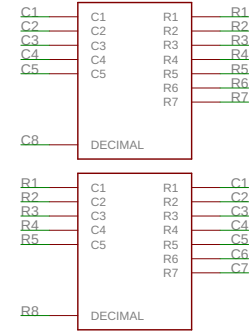

Matrix Driver  
Address: 0x62

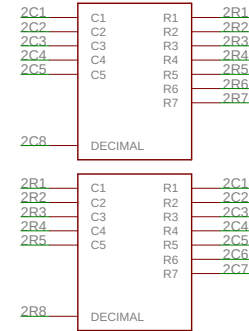
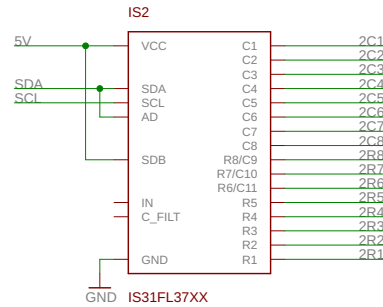

Matrix Driver Decoupling

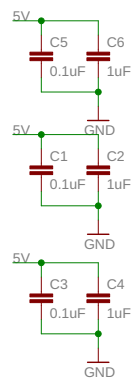

Matrix Driver  
Address: 0x61

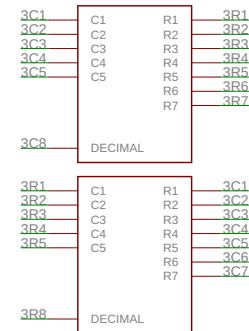
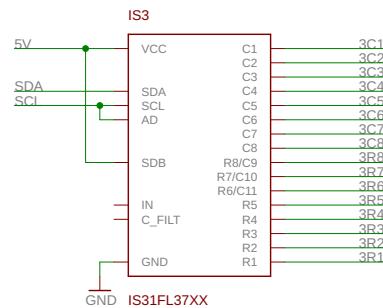

Matrix Driver Address Select  
 AD connected to GND, AD=1100000 0x60  
 AD connected to VCC, AD=1100011 0x63  
 AD connected to SCL, AD=1100001 0x61  
 AD connected to SDA, AD=1100010 0x62