

# Inky Frame 4.0" (PIM654 / PIM661): EPD Display & circuitry

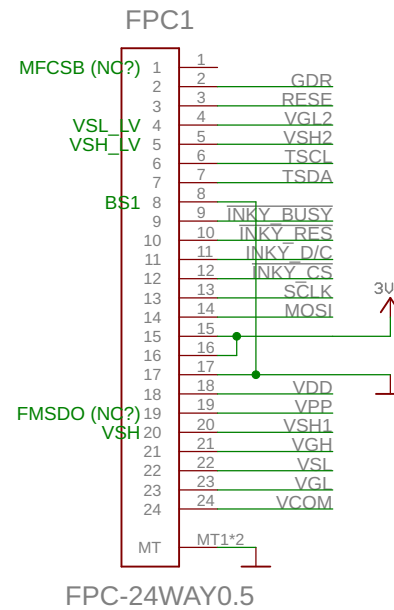

# Inky Frame 4.0" (PIM654 / PIM661): Power & RTC

## Wake from power-down connections

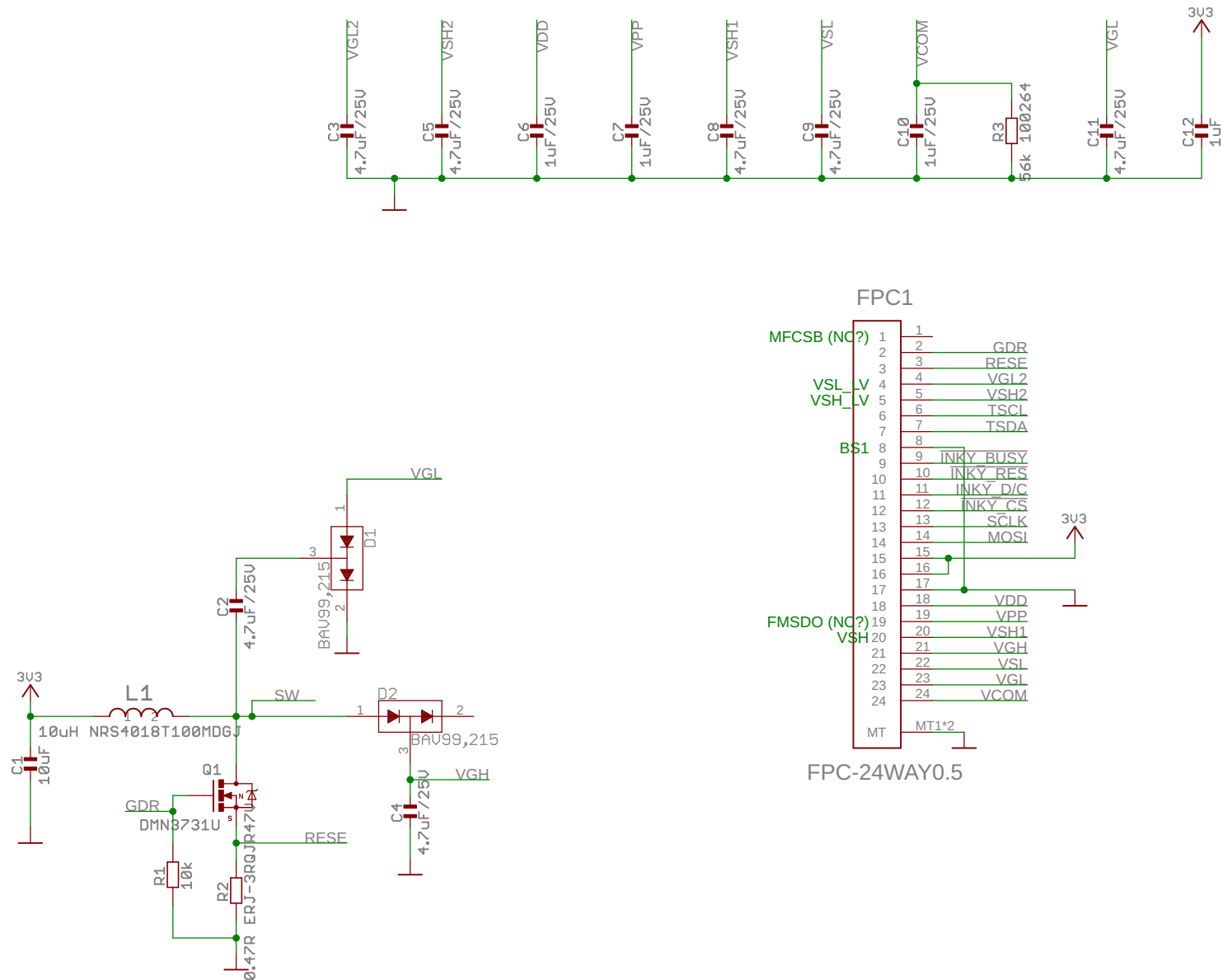
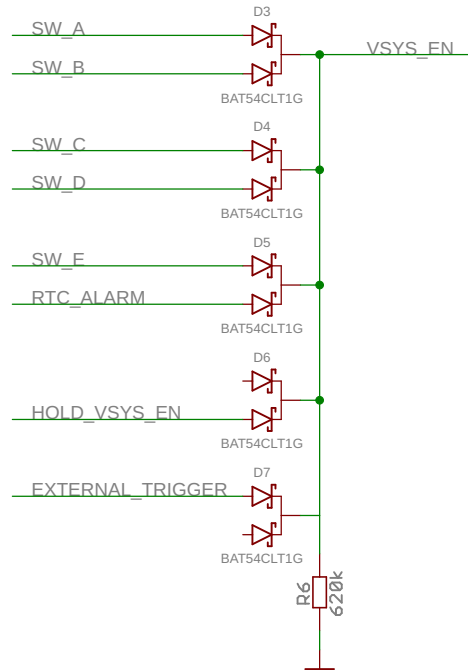

## RTC with crystal

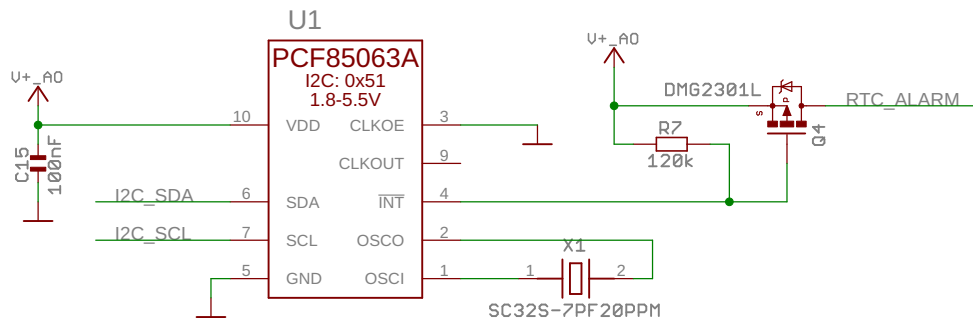

## Battery connector & power

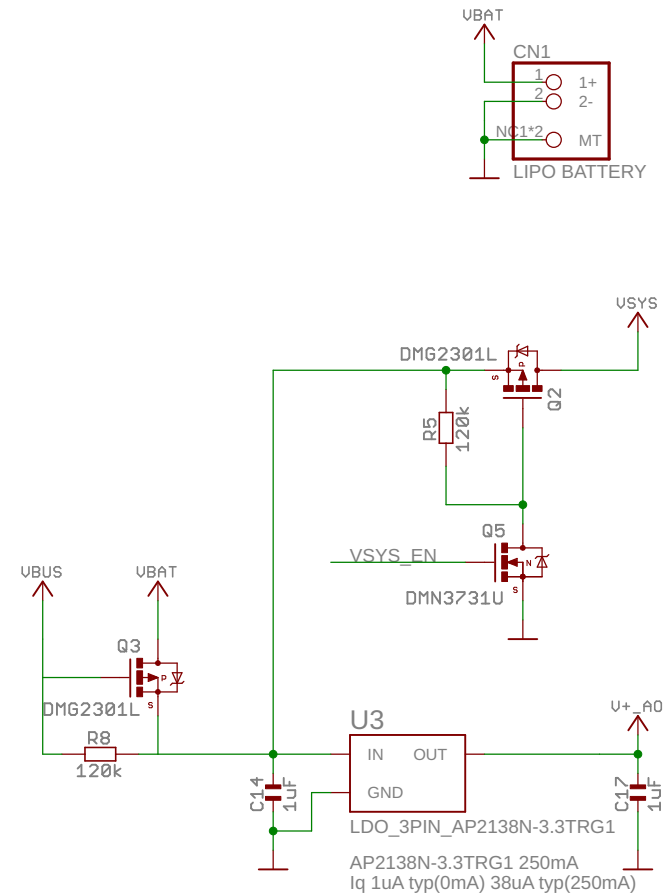

# Inky Frame 4.0" (PIM654 / PIM661): Pico W & co

## Raspberry Pi Pico W

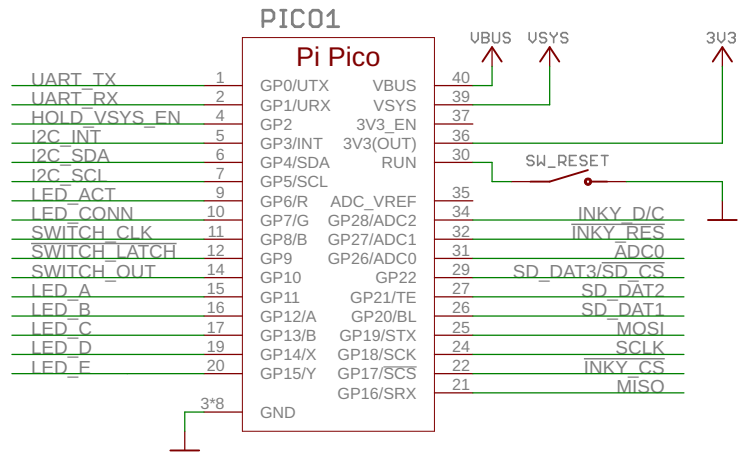

## QW/ST connectors

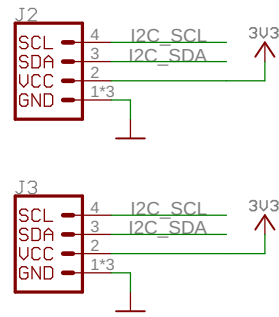

## I2C Pullups

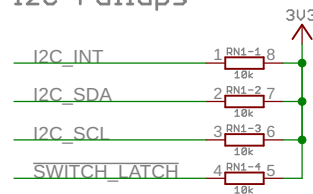

Pull-up on SWITCH\_LATCH is used to detect the display size (4.0")

## Input pull-downs

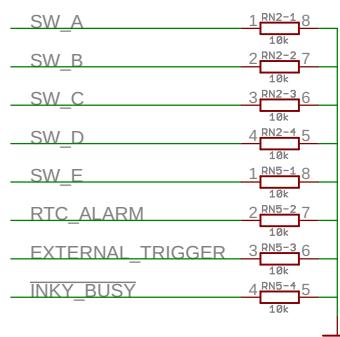

## Switches and LEDs

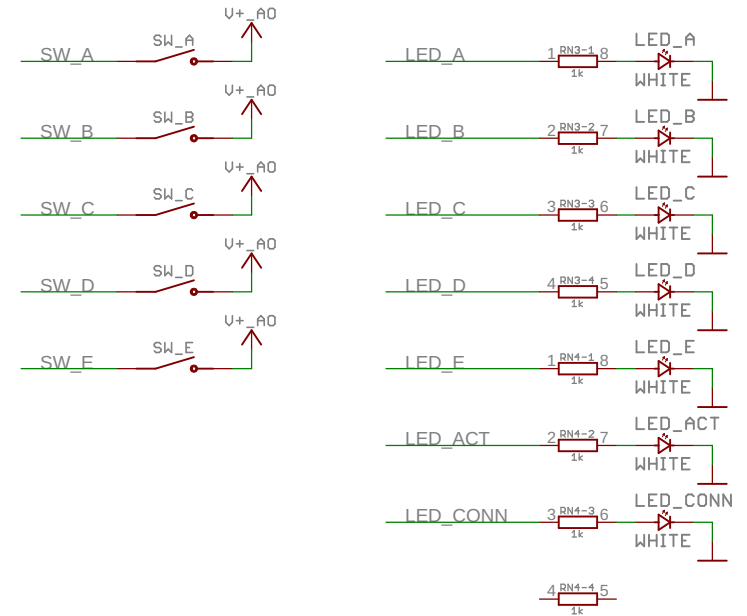

## Shift register for inputs

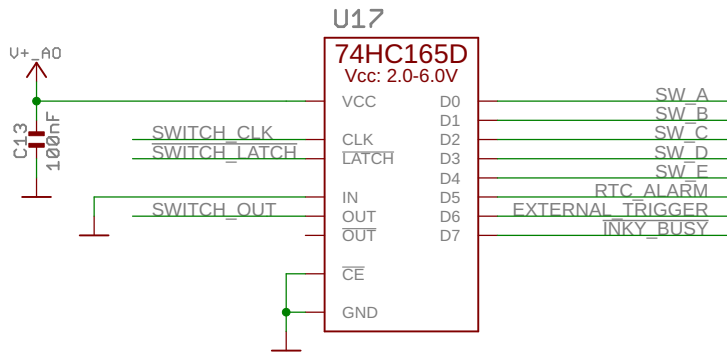

## Expansion header and debug pads

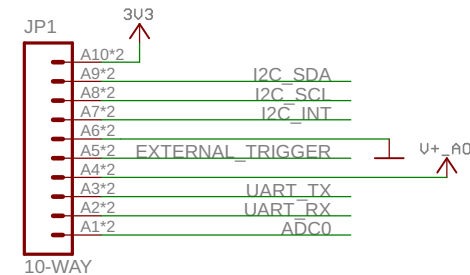

# Inky Frame 4.0" (PIM654 / PIM661): MicroSD

