

# Enviro for Raspberry Pi - Enviro + Air Quality (PIM458)

Pi GPIO connector

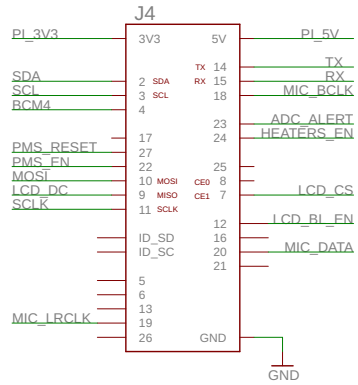

5V -> 3V3 LDO Regulator for sensors

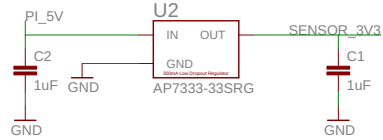

MICS-6814 Analog NO2 & CO & NH3 Sensor

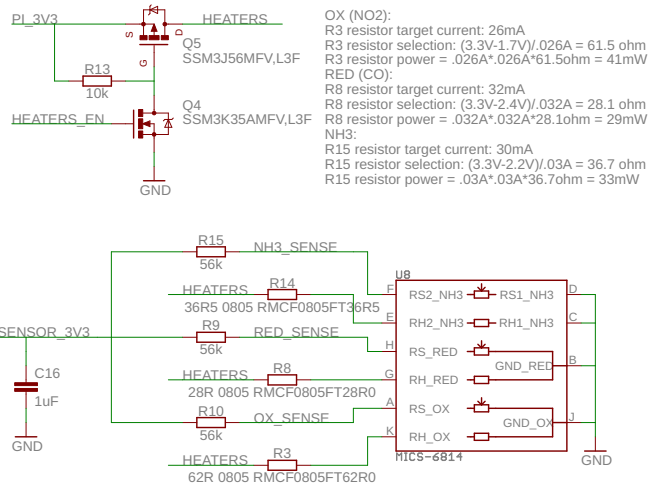

ADC

ADS1015  
 i2c addr = 0x49  
 Current < 1mA

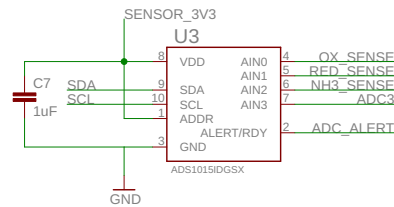

BME280 Temperature + Humidity + Pressure Sensor

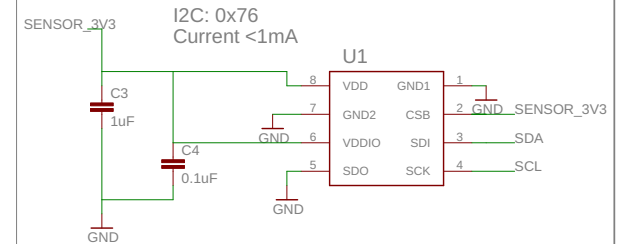

LTR-559 digital light sensor

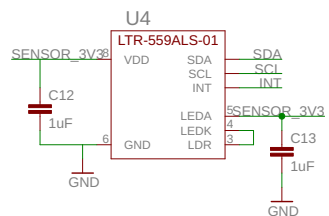

Connection for PMS5003 / 7003 PM Sensor

Current < 100mA @ 5V

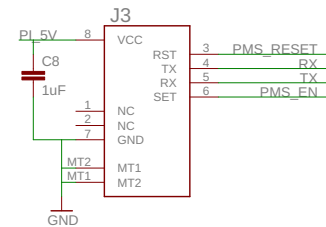

Digital I2S microphone

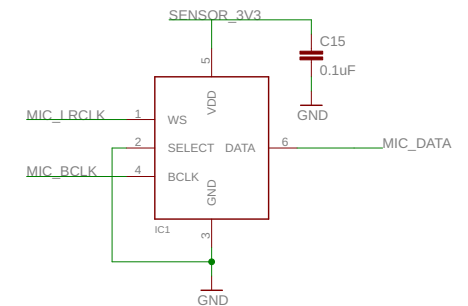

I2C & ADC extension header, unpopulated  
 Breakout Garden Pinout

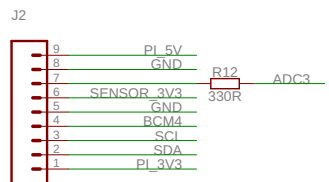

0.96" 160x80 LCD

