



MATHIAS BÄUERLE

Mathias Bäuerle GmbH · Gewerbehallestraße 7-11

D-78112 St.Georgen · Telefon (07724) 882-0 · Telefax (07724) 882-111

Internet: <http://www.mbfold.de> · E-mail: [center@mbfold.de](mailto:center@mbfold.de)

---



## Fold System multipli 35

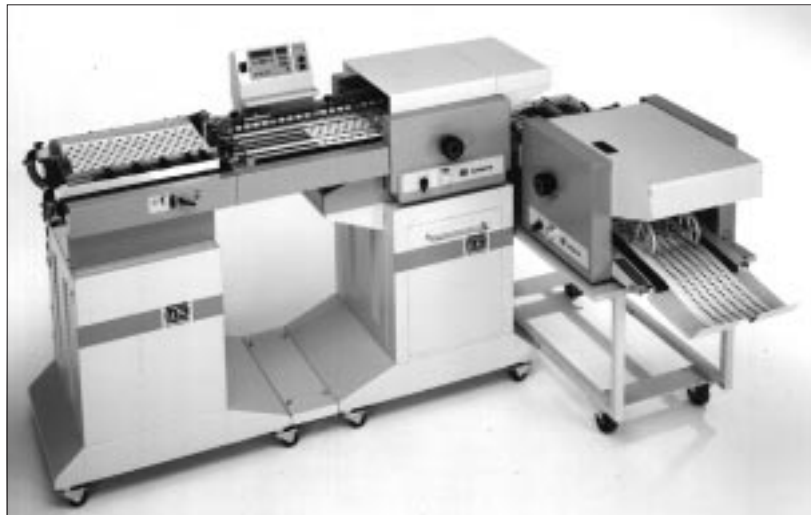

# Operator's Manual

---

# CONTENTS

<b>1. General</b>	5
<b>2. Specifications</b>	6
<b>3. Proper Handling of the Machine</b>	7
<b>4. Safety Instructions</b>	9
<b>5. Safety Features</b>	13
<b>6. Components of the Machine</b>	14
<b>7. Space Requirements</b>	15
<b>8. Operator Positions</b>	15
<b>9. Friction Feeder F 35</b>	17
Function	17
Description	17
Setting the Format	18
Setting the Sheet Separation	19
Fanning the Paper Stack	20
Loading the Feed Table	20
<b>10. Air Feeder S 32</b>	21
Principle of Operation	21
Description	21
Setting the Format	22
Setting Sheet Separation	23
Setting the Air	23
Front Paper Stop	27
Setting the Sheet Gap	28
Positioning the Paper Stack	28
<b>11. Air Feeder PBA 35</b>	29
Principle of Operation	29
Description	29
Setting the Format	30
Setting the Sheet Separation	31
Setting the Sheet Gap	35
Positioning the Paper Stack	35
Balls in the Register Table	36
<b>12. Buckle Fold Unit 35/2 and 35/4</b>	37
Description	37
Fold Plate Positions	38
Inserting the Fold Plates and Deflectors	39
Setting the Fold Plate Stops	40
Long Fold Plate LFT 35	40
Setting Guide for Common Types of Fold	40
Adjusting the Ejector Rollers	43
Transfer Bridge	43
Roller Table	44

<b>13. Standard Fanned Delivery</b>	45
<b>14. Fanned Delivery A 35</b>	46
<b>15. Operation and Trial Folds</b>	49
multipli 35 F (Friction Feeder)	49
multipli 35 S / multipli 35 PBA (without Operator Panel)	50
multipli 35 PBA (with Operator Panel)	51
<b>16. Fine Adjustments and Corrections</b>	52
Fold Length	52
Skewed Folds	52
Correction of Skewed Folds	53
Out-of-Square Paper	53
<b>17. Perforating-, Scoring- and Slitting Tools</b>	55
Perforating	56
Scoring	57
Slitting	57
Installation of the Tools	58
<b>18. Total Counter</b>	59
<b>19. Batch Counter</b>	59
Description	60
Operating Modes	62
Continuous Suction / Streamfeed	62
Control of Sheet Gap	63
Total Counter	64
Permanent Counter	64
Setting the Batch Count	65
Switching on the Batch Counter	65
Setting the Desired Number of Sheets	65
Setting the Interval Time	65
Batch Counting for Two-up and Three-up	66
Sheet Gap Control	67
Switching on the Sheet Gap Control	67
Setting the Sheet Gap	67
Speed Display	67
Paper Travel Control	67
<b>20. Double Sheet Detection</b>	68
<b>21. Trouble Shooting Guide</b>	71

The title, copyright and all other proprietary rights in this document are vested in Mathias Bäuerle GmbH and no part of it may be reproduced in any form without the written permission of Mathias Bäuerle GmbH.

# 1. GENERAL

## General Description

The machines of the multipli 35 folder line work on the buckle fold principle. They can be used for a wide range of applications because it is possible to choose between different types of feeders or to use one or two fold units.

The most important folds are:

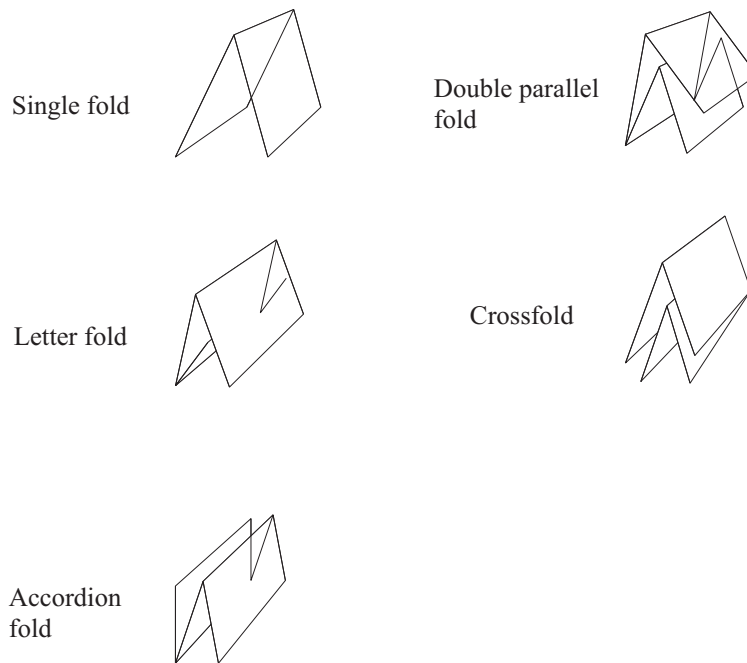

## Fold Principle

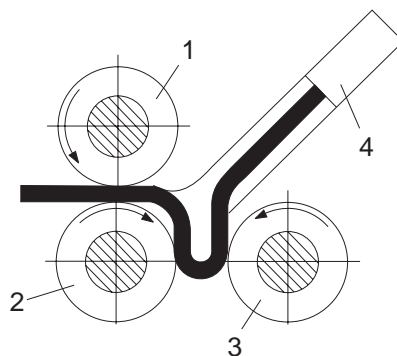

The infeed rollers (1 and 2) transport the sheet to be folded into the fold plate (4).

As soon as it comes up against the adjustable stop, the sheet forms a buckle because the infeed rollers keep on moving.

The loop gets bigger until the sheet is seized by rollers (2) and (3); this is where the actual fold occurs.

The rollers draw the folded sheet from the fold plate and the infeed rollers and move it on.

## 2. SPECIFICATIONS

<b>Paper size:</b>	max. size	min. size
<i>Bottom feed, top-loading air feeder PBA 35:</i>	35 x 45 cm	8.5 x 12 cm (width x length)
<i>Bottom feed, top-loading air feeder S 32:</i>	32 x 45 cm	8.5 x 12 cm (width x length)
<i>Friction feeder F 35:</i>	35 x 54 cm	5 x 7 cm (width x length)
<i>Fold unit II:</i>	32 x 45 cm	8.5 x 12 cm (width x length)
<b>Fold length:</b>	36 cm	5 cm
Long fold plate LFT 35:	43 cm	5 cm
<b>Speed:</b>	Air feeder:	30,000 sheets/h
	Friction feeder:	20,000 sheets/h
		when folding from A4 to A5, paper weight 80
<b>GSM</b>		
<b>Paper weight:</b>	40 - 250 GSM for single parallel fold	
<b>Electrical:</b>	Voltage:	230V
	Current consumption:	max. 10A
	Power consumption:	
	1st fold unit, F35 or F32:	0.3 kW
	1st fold unit, PBA 35:	0.4 kW
	2nd fold unit, roller table:	0.4 kW
	Pump:	0.7 kW
<b>Ambient conditions:</b>	Temperature:	15 - 40°C
	Humidity:	50 - 90%
<b>Net weight of machine:</b>	1st fold unit 35/2, F35:	35 kg
	1st fold unit 35/2, S32:	45 kg
	1st fold unit 35/4, S32:	60 kg
	1st fold unit 35/2, PBA 35:	80 kg
	1st fold unit 35/4, PBA 35:	100 kg
	2nd fold unit 35/2, transfer bridge, roller table:	70 kg
	2nd fold unit 35/4, transfer bridge, roller table:	90 kg
	Standard fanned delivery:	4 kg
	Fanned delivery A35:	15 kg
	Transfer bridge:	5 kg
	Pump:	16 kg
	Stand for friction machines:	39 kg
	Stand for suction machines:	36 kg
	Stand for PBA machines:	70 kg
	Stand for 2nd fold unit:	23 kg
<b>Noise emission:</b>		
	Sound pressure level multipli 35/2, S:	measured at feeder: 83 dB(A)
		measured at delivery: 82 dB(A)
	Sound pressure level multipli 35/2/2, S:	measured at feeder: 80 dB(A)
		measured at delivery: 77 dB(A)

### 3. PROPER HANDLING OF THE MACHINE

The machines of the multipli 35 folder line are built for folding paper. They may also be used for perforating, scoring, slitting, cutting and counting paper using the proper attachments. They are unsuitable for handling other materials, such as foils, plastics and textiles. The manufacturer / distributor is not responsible for damages resulting from such unsuitable applications. Responsibility lies alone with the user.

Installation of the machine, i.e. assembling as well as electrical and pneumatic work should be carried out only by skilled personnel authorized by the manufacturer or his representatives.

Additional instructions are provided for this purpose.

Repairs and service should be carried out only by skilled personnel authorized by the manufacturer or his representatives.

The interval between inspections including safety-related functions depends on the machine usage.

For regular one-shift operation, one inspection per year is recommended.

The folders may be placed on already existing sturdy tables or on mobile stands available from the manufacturer.

The machine weight should be considered when choosing a table for the folder.

The mobile stands are equipped with casters which can be locked to guarantee the stability of the machine during operation.

The line voltage must correspond to the voltages on the serial plate.

Read the Operator's Manual before working with the machine!

We recommend to carry out all operations and settings in the sequence mentioned in this manual so that nothing is overlooked.



**The terms "right" or "left" in the following text always refer to the direction of paper travel. Therefore the right side is the operator side.**

## 4. SAFETY INSTRUCTIONS

### 4.1 Safety Instructions for Transport and Set-Up

The following instructions and warnings are applied to the packing to ensure appropriate and safe transport:



**Top! - Transport in upright position only!**

**Protect from humidity!**

**Fragile!  
Handle with care!**

These instructions and warnings must also be observed for transport within the users premises.

For transport to other premises resp. for return shipment the machines must be packed and provided with the same markings.

### 4.2 Fundamental Safety Instructions

#### Warnings and Symbols

The following symbols and designations are used in the manual to identify instructions of particular importance:



General instructions and special information on how to use the machine most efficiently.



Instructions designed to prevent injury or extensive equipment damage.

### Basic Operation

The machine has been built in accordance with state-of-the art standards and the recognized safety rules.

Nevertheless, operators and third parties may get injured when working with the machine, or damage to the machine and to other material property may result.

The machine must only be used in a technically perfect condition in accordance with its designated use and the instructions set out in the operator's manual.

Any malfunctions, especially those affecting the safety of the machine, should therefore be rectified immediately.

## Organizational Measures

The operator's manual must always be available near the machine.  
In addition to reading the operator's manual, observe and instruct the user in all other generally applicable legal and other mandatory regulations relevant to accident prevention and environmental protection.

The operator's manual must be supplemented by instructions covering the duties involved in supervising and notifying special organizational features, such as job organization, working sequences or the personnel entrusted with the work.

Personnel entrusted with work on the machine must have read the operator's manual and in particular the chapter on safety before beginning the work.

Reading the instructions after work has begun is too late.

This applies especially to persons working occasionally on the machine, e.g. during setup or maintenance.

Check, at least from time to time, whether the personnel is carrying out the work in compliance with the operator's manual and paying attention to risks and safety factors.

For reasons of safety, long hair must be tied back or otherwise secured, garments must be close-fitting and no jewellery - such as rings - may be worn.

Injury may result from being caught on moving parts.

Observe all safety instructions and warnings attached to the machine.

See to it that safety instructions and warnings attached to the machine are always complete and perfectly legible.

In the event of safety-relevant modifications or changes in the performance of the machine during operation, stop the machine immediately and report the malfunction to the competent person.

Never make any modifications, additions or conversions which might affect safety without the manufacturer's approval. Adhere to prescribed intervals or those specified in the operator's manual for routine checks and inspections.

## Selection of Personnel, Basic Responsibilities

Employ only trained or instructed staff and set out clearly the individual responsibilities of the personnel for operation, set-up, maintenance and repair.

Work on the electrical system and equipment of the machine must be carried out only by a skilled electrician or by instructed persons under the supervision and guidance of a skilled electrician and in accordance with electrical engineering rules and regula-

## Standard Operation

Avoid any operational mode that might be detrimental to safety.

Take the necessary precautions to ensure that the machine is used only in a safe and reliable state. Operate the machine only if all protective and safety-oriented devices, such as removable safety devices, emergency stops, sound proofing elements, are in place and fully functional.

In the event of malfunctions, stop the machine immediately and prevent further use.

Have any defects rectified immediately.

Before starting up or setting the machine in motion, make sure that nobody is in danger.

## Special Work, Maintenance, Repair

Observe the adjusting, maintenance and inspection activities and intervals set out in the operator's manual, including information on the replacement of parts and equipment.

If the machine is completely shut down for maintenance and repair work, it must be secured against inadvertent starting by attaching a warning sign to the main switch. Always tighten any screw connections that have been loosened during maintenance and repair.



## Special Dangers

The electrical equipment of machines is to be inspected and checked at regular intervals.  
Defects such as loose connections or scorched cables must be rectified immediately.

## Product-Specific Safety Instructions



**Exercise caution in the vicinity of rotating shafts and rollers!  
Hair, loose garments and jewellery may get caught!  
SERIOUS INJURY MAY RESULT!**



**Exercise caution in the vicinity of the perforating- and slitting knives!  
They have sharp edges for proper function!  
SERIOUS INJURY MAY RESULT!**

## 4.3 Cleaning and Maintenance

Regular and proper cleaning contributes to a long life of the machine and a consistent quality. Therefore it is important to clean the machine in regular intervals and above all to remove paper dust.

The interval between maintenance jobs depends on the workload.  
It is recommended to clean the machine once a week.



**Before cleaning the machine always pull the power plug!**



**Exercise caution in the vicinity of the perforating- and slitting knives!  
They have sharp edges for proper function!  
SERIOUS INJURY MAY RESULT!**

The maintenance-free flat belt drive needs no greasing or oiling.

The fold rollers consist of polyurethane foam and are impregnated with an antistatic liquid.

The rollers must **not** be washed with cleaning fluids such as roller- or blanket cleaner. This would damage the antistatic surface and cause folding problems.  
If cleaning is required, **use a stiff brush**, no liquids of any kind.



## 5. SAFETY FEATURES

The models of the multipli 35 folder line are equipped with various safety features. They ensure the safety of the persons working with the machines.

The machines are equipped with the following safety features:

- Fixed cover at the fold roller infeed section (1)
- Swing-up and removable noise covers (2)
- Safety handwheels (3)

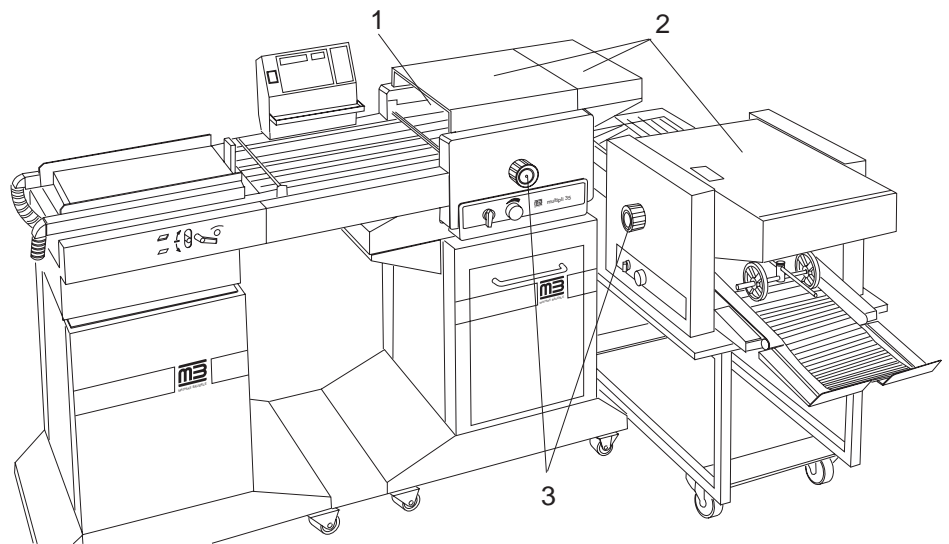

Possible remaining risks are pointed out in the respective paragraphs of this manual.

## 6. COMPONENTS OF THE MACHINE

As a result of its modular design, the multipli 35 series offers a wide range of applications and configurations to suit the requirements of the user.

The following components are available:

- Friction feeder F35
- Air feeder without register table - S32
- Air feeder with register table - PBA 35
- First fold unit with 2 fold plates
- First fold unit with 4 fold plates
- Second fold unit with 2 fold plates and roller table
- Second fold unit with 4 fold plates and roller table
- Fanned delivery
- Mobile stands

The model number shows the machine configuration, for example:

<b>multipli 35/2 F</b>	
35	Infeed width 35 cm
2	1st buckle fold unit with 2 fold plates
F	Friction feeder F35
<b>multipli 35/4 S</b>	
35	Infeed width 35 cm
4	1st fold unit with 4 fold plates
S	Air feeder without register table S32
<b>multipli 35/4 /2 PBA</b>	
35	Infeed width 35 cm
4	1st fold unit with 4 fold plates
2	2nd fold unit with 2 fold plates
PBA	Air feeder with register table PBA 35

The following machine configurations are possible in the multipli 35 folder line:

- Machines with friction feeder F35:
 

multipli 35/2 F	
multipli 35/2/2 F	
multipli 35/2/4 F	
- Machines with air feeder S32 without register table:
 

multipli 35/2 S	multipli 35/2/4 S
multipli 35/4 S	multipli 35/4/2 S
multipli 35/2/2 S	multipli 35/4/4 S
- Machines with air feeder PBA with register table:
 

multipli 35/2 PBA	multipli 35/2/4 PBA
multipli 35/4 PBA	multipli 35/4/2 PBA
multipli 35/2/2 PBA	multipli 35/4/4 PBA

## 7. SPACE REQUIREMENTS

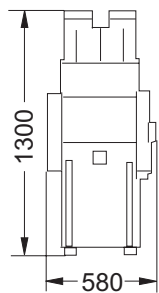

multipli 35/2 S

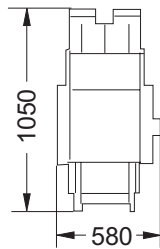

multipli 35/2 F

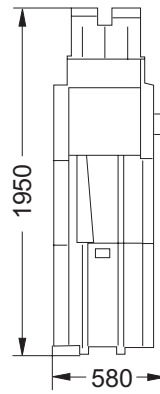

multipli 35/2 PBA

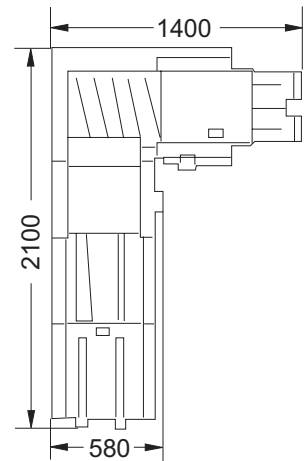

multipli 35/2/4 PBA

## 8. OPERATOR POSITIONS

There is no fixed operator position at the machines.  
The operator must move between the following positions:

- 1 Feeder section for loading the unfolded paper
- 2 Fold unit for set-up
- 3 Delivery section for removing the folded paper

In addition, the machines are accessible from any other position for cleaning, resetting, jam clearance, service jobs, etc.

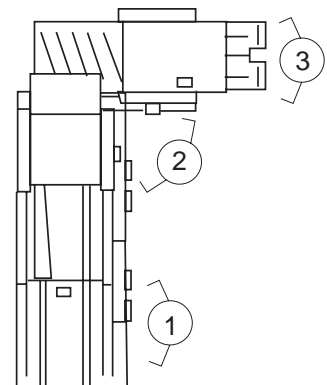

# 9. FRICTION FEEDER F 35

## Function

The friction feeder F35 is especially suitable for separating uncoated and recycled papers.  
 When handling coated paper such as art- or vellum papers, markings may occur which could impair the quality.

Sheet separation is done by friction from the top of a fanned paper stack.  
 The feeder is driven by the feed roller (2), which in turn moves the infeed roller (1).  
 The pressure roller (3) under the feed roller is stationary.

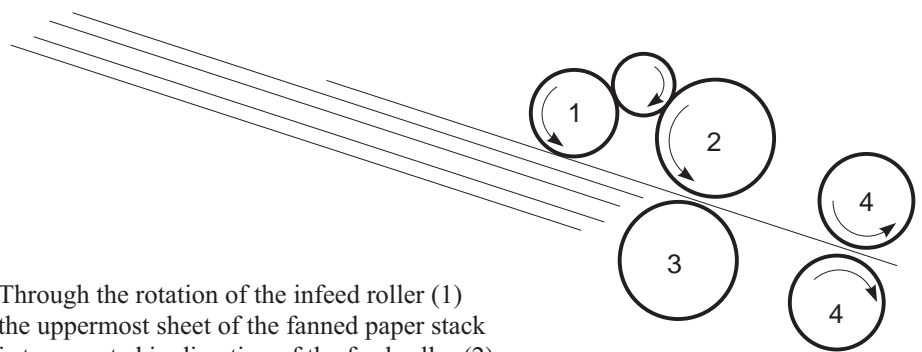

Through the rotation of the infeed roller (1) the uppermost sheet of the fanned paper stack is transported in direction of the feed roller (2).  
 When the sheet reaches the feed roller (2), it is gripped by the roller and the rotating movement moves the sheet on to the first pair of rollers (4) where the actual fold occurs.  
 As soon as the trailing edge of the sheet has left the feed roller, the infeed roller grips the next sheet from the top and again transports it in direction of the feed roller.

## Description

- 5 Feed table
- 6 Feed guide left and right
- 7 Knurled nut for adjusting the feed guide
- 8 Guide holes

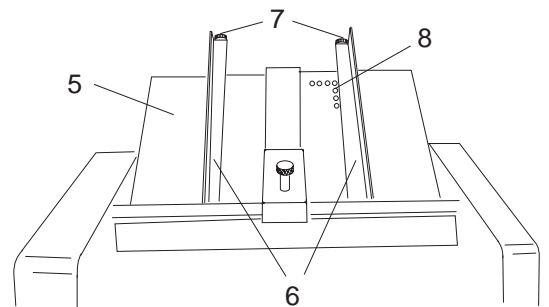

- 9 Feeder
- 10 Knurled nut for changing the contact pressure on the feeder
- 11 Infeed roller

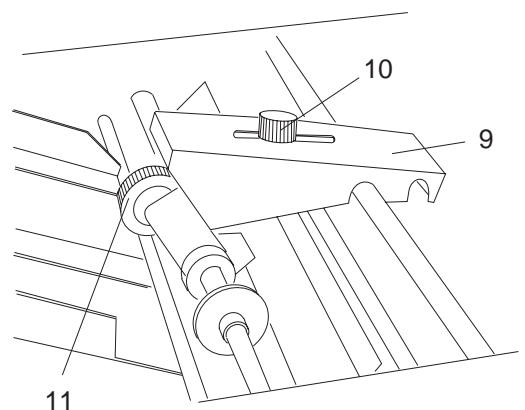

## Description

- 1 Feed roller
- 2 Pressure roller
- 3 Hold-down disks

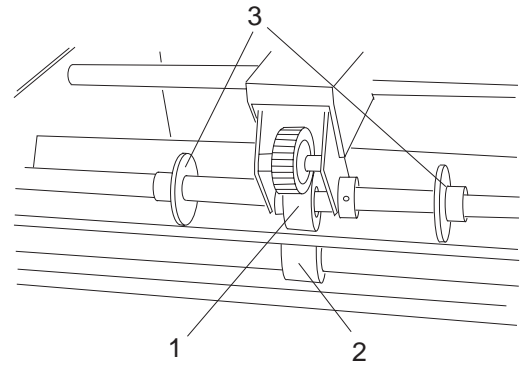

- 4 Paper thickness setting disk

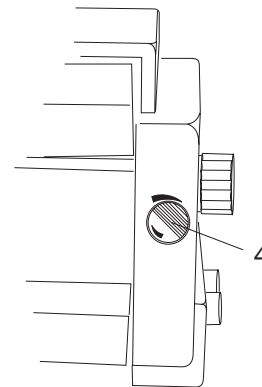

## Setting the Format



When setting the format, care should be taken that the sheets are fed approximately from the center.

- Loosen the knurled nut (5) at the two feed guides by turning it counter-clockwise.
- Set both feed guides roughly to the desired format.
- Manually fold a sample sheet lengthwise down the middle (7).
- Place the sample sheet (7) on the feed table in such a way that the fold is located roughly near the center of the feed roller.
- Place the left feed guide (6) against the sheet, using the locating holes (8) as a guide.
- Tighten the knurled nut (5) of the left feed guide.
- Slide the right feed guide against the edge of the sheet without actually touching it, leaving a gap of approx. 0.5 mm.
- Tighten the knurled nut of the right feed guide.
- Displace the hold-down disks (3) in such a way that they serve as guides about 2 - 3 cm from the edge of the sheet.

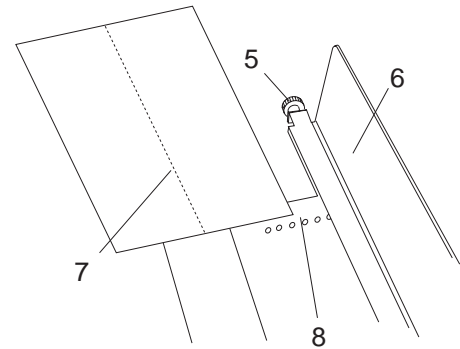

## Setting the Sheet Separation



**Exercise caution in the vicinity of rotating shafts and rollers!  
Hair, loose garments and jewellery may get caught!  
SERIOUS INJURY MAY RESULT!**

- Switch on the machine - knob (1) in position I.
- Move the feeder until it audibly engages in the rest position (2).
- Push open the setting disk (3) and turn it counter-clockwise by about one turn. This lowers the pressure roller. The gap between feed- and pressure roller is increased.
- Slide an unfolded sheet between feed- and pressure roller and hold it tight (4).

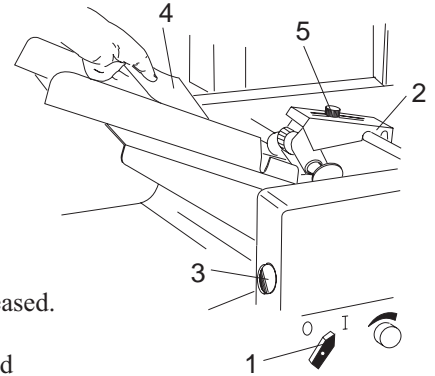

Hold on to the sheet to avoid that it is gripped by the feed roller and then folded.

- Keep the sample sheet in this position and use your other hand to slowly turn the setting disk (3) clockwise until you feel a slight resistance when pulling back the sheet. The gap between feed- and pressure roller is now set to the thickness of the sheets to be folded. Now remove the sample sheet.
- Switch off the machine - knob (1) in position 0.
- Place the setting disk (3) back in rest position to avoid accidental movement. Corrections can be made with the machine running.
- Loosen the knurled nut (5) at the feeder. By changing the location of the knurled nut the contact pressure at the feeder can be set to the type of paper:

### ***Light grades of paper (below 60 GSM):***

Only light pressure necessary, push in direction of the delivery section.

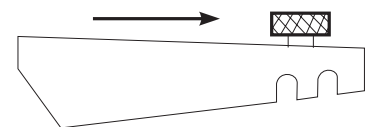

### ***Medium weight papers (60 to 90 GSM):***

The weight of the feeder itself is sufficient, neutral mid-position.

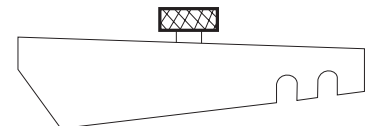

### ***Heavy paper grades (more than 90 GSM):***

Higher pressure needed, push in direction of feed section.

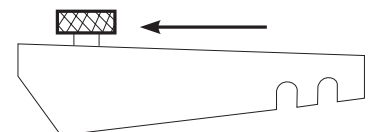



## Fanning the Paper Stack

Proceed as follows to fan out the paper stack before placing it on the feed table:

- Grip the left end of the paper stack with your left hand and bend it towards the right.
- Push down the right side of the stack with your right hand.
- While still holding down the right side of the stack, release the left side, which will snap back to its original position. The stack is fanned out slightly. Repeat this procedure once or twice until the stack is fanned out properly.

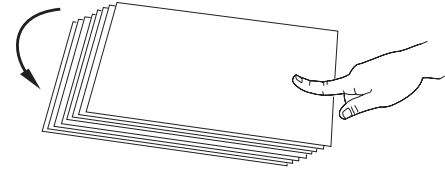
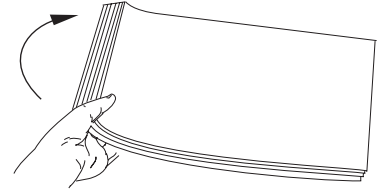

## Loading the Feed Table

- Slide the feeder back to rest position (1).
- Place the fanned out stack on the feed table and slide it under the feed- and infeed rollers.

 Position the stack in such a way that the uppermost sheet is located under the feed roller.

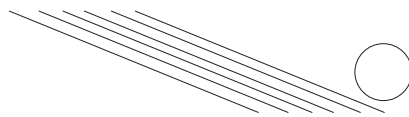

- Set the feeder to work position (2).

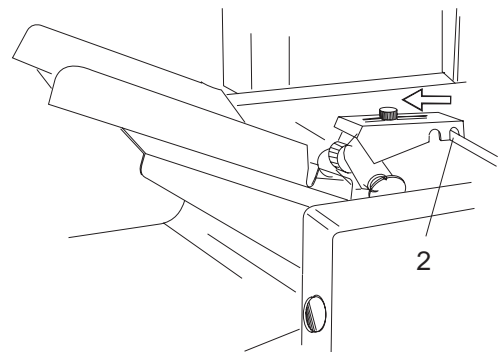
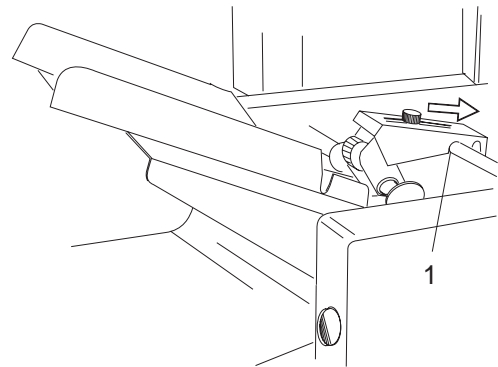

# 10. AIR FEEDER S 32

## Principle of Operation

The air feeder S32 is suitable for handling a wide variety of papers. It separates uncoated paper as well as coated, freshly printed or thin papers. The sheets are separated by air and vacuum. Air is supplied from the bottom of the stack both on the left and right side, separating the paper in the stack which now floats on a cushion of air. A rotating suction drum can then separate the sheets from the bottom of the paper stack. This principle has the advantage that paper can be reloaded continuously. There is no need to stop the machine.

## Description

Components and operating elements of the air feeder S 32:

- 1 Rear paper stop
- 2 Air guides left and right
- 3 Feed table
- 4 Front paper stop
- 5 Knurled screw for locking the suction segment
- 6 Lever for adjusting the suction segment
- 7 Air regulating valves
- 8 Knobs for adjusting and locking the air guides
- 9 Suction drum

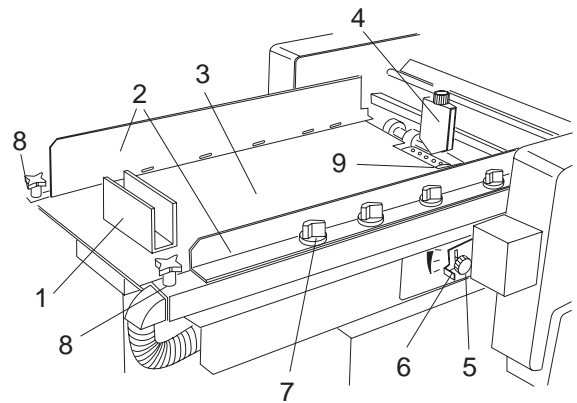

- 10 Hold-down balls
- 11 Handle for adjusting and locking the air guides
- 12 On/off switch for pump

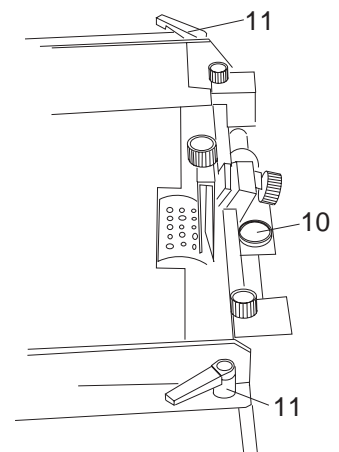
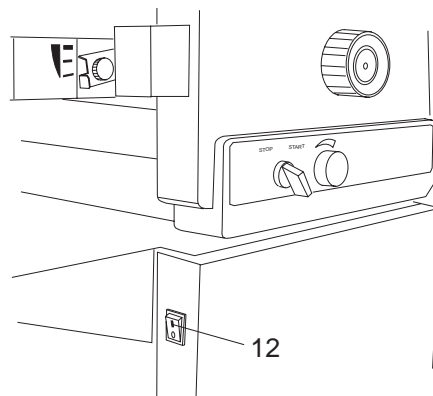

## Setting the Format



The paper should be positioned in such a way that it is fed approximately from the center.

- Loosen the knobs (1) by turning them counter-clockwise.
- Loosen the lock levers (2) by turning them counter-clockwise. They can be moved to a convenient position for tightening by lifting and then turning them.
- Set the left air guide to half the paper width with the help of the scale (3).

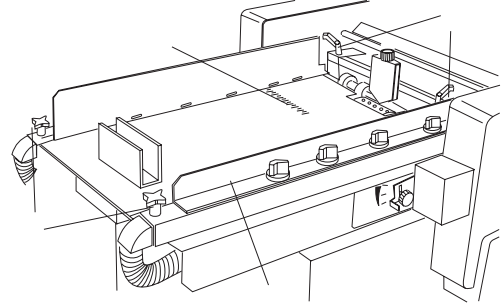

- Tighten the knob and the lock lever of the left air bracket.
- Place a paper stack of about 50 sheets on the feed table.
- Slide the right feed guide (4) against the stack.



Do not pinch the stack, leave at least 0.5 mm between paper stack and guide.

- Tighten the knob and the lock lever of the right air guide.

## Setting Sheet Separation

Sheet separation is achieved by the combined action of the rotating suction drum, the paper stop and the air.  
Paper weight and type of paper have an influence on the setting.

### Setting the air:

A suction drum (1) separates the sheets from the bottom of the paper stack. This is achieved by the suction segment (2) inside the suction drum. The angle of the suction segment with respect to the paper stop can be changed to suit the different types of paper.

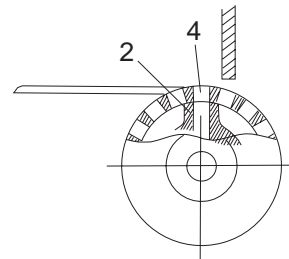
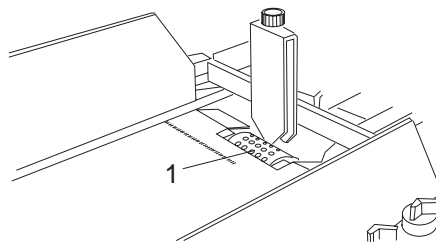

### Basic setting:

- By turning the handwheel, move the suction drum (3) to such a position that a row of suction holes (4) is in the uppermost position of the suction drum.

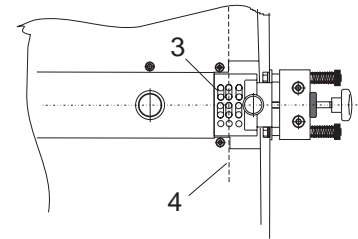

Proper adjustment can be checked as follows:

Place a sheet (5) against the edges of the cutout in the suction drum (6). This marks the centerline of the drum.

The sheet must cover the left half of the suction holes (7), while the right half (8) is still visible.

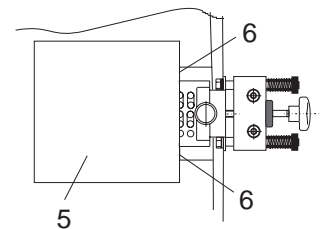

- Change the angle of the suction segment in such a way that the openings in the suction segment (9) line up with the next row of suction holes (10) in direction of paper travel.

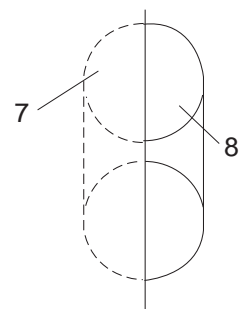
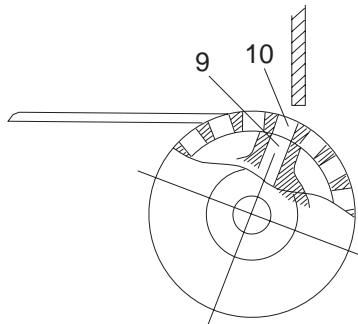

Set the suction segment as follows:

- Loosen the knurled screw (1) by turning it counter-clockwise.
- Move the swivel lever (2) up or down, thus swinging the suction segment to the required position.

Heavy paper grades: move swivel lever up  
Light paper grades: move lever down

- Tighten the clamp lever by turning it clockwise.

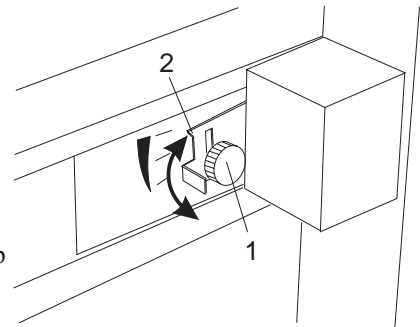

### Setting for light paper grades:

Light paper grades easily cling to the curve of the suction drum. Therefore, the suction segment must be tilted in direction of the paper stop.

 For running light-weight paper, first try the setting as described under "Basic Setting".

The inclination of the suction segment in this direction has the effect that the paper is wrapped around the suction drum (4). The sheets are easily separated from the stack and double sheets occur very rarely.

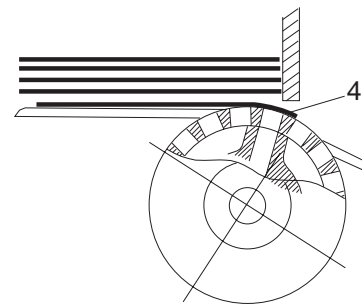

### Setting for heavy paper grades:

Heavier paper grades do not easily cling to the curve of the suction drum. For this reason, the suction segment must be tilted in direction of the paper stack.

The inclination of the suction segment in this direction has the effect that the paper is wrapped around the suction drum (5) very little. This is sufficient because heavier paper grades are more easily separated from the paper stack.

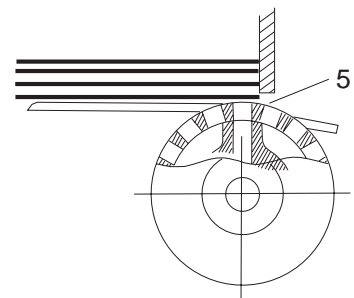

**Air:**

Open the valves (1) at both air brackets.

 In most cases it is sufficient to open the second and the last valve (with reference to the format length).

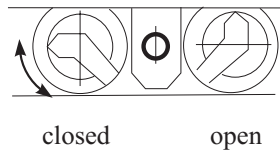
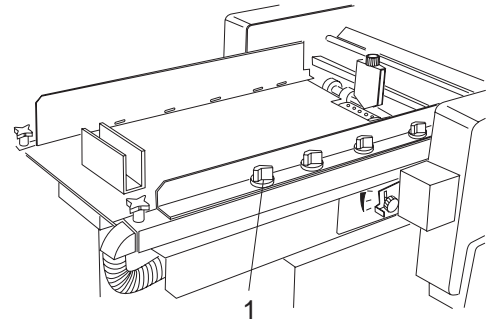

**Air and vacuum:**

Air and vacuum can be modified by means of air-regulating valves. This is necessary because heavy paper grades require more vacuum and air than light paper grades.

- Valve for vacuum at the suction drum (1)
- Valve for air at the right air guide (2)
- Valve for air at the left air guide (3)

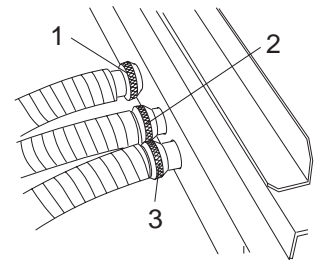

Air and vacuum can be modified by means of sliding collars (valves).

Bleeder hole covered completely: maximum effect

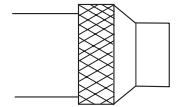

Bleeder hole half open: reduced effect

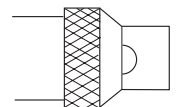

Bleeder hole completely open: minimum effect

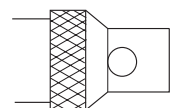

**Setting the vacuum:**

For setting the vacuum, the machine must be turned on.



**Exercise caution in the vicinity of rotating shafts and rollers!**  
**Hair, loose garments and jewellery may get caught!**  
**SERIOUS INJURY MAY RESULT!**



**Do not get close to rotating shafts and rollers while the machine is running and the noise-absorbing cover is open!**  
**SERIOUS INJURY MAY RESULT!**



**Exercise caution in the vicinity of the perforating- and slitting knives!**  
**They have sharp edges for proper function!**  
**SERIOUS INJURY MAY RESULT!**

- Open the bleeder hole for setting the minimum effect.
- Start the machine.
- Slowly slide the collar over the bleeder hole. Observe sheet separation while doing this.

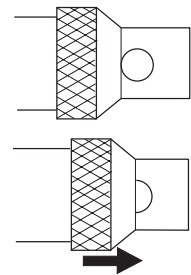

At first no sheets are pulled off the stack or they are pulled off irregularly. The more the collar covers the bleeder hole, the smoother the paper transport.



Leave the collar in the position where even separation is obtained.



Make sure that much vacuum does not cause feeding of double sheets.

- Switch off the machine.

**Adjusting the front paper stop:**

The position of the front paper stop (1) can be adjusted in a horizontal and vertical direction.

*Adjusting the horizontal position:*

The horizontal position of the front paper stop determines the suction point on the paper and in turn depends on the position of the suction segment in the suction drum.

 The inclination of the suction segment must be set correctly before making the horizontal adjustment (see page 23/24).

 When the suction segment is adjusted, the horizontal position must also be changed accordingly.

- Turn the handwheel until the openings of the suction drum (2) are exactly above the openings of the suction segment (3).
- Adjust the horizontal position of the front paper stop in such a way that it forms a vertical line (4) with the leading edge of the suction openings. To achieve this, turn the knurled screw (5) counter-clockwise or clockwise.

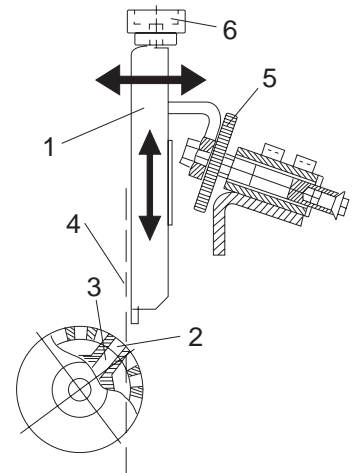
*Adjusting the vertical position:*

The respective paper thickness is set by adjusting the vertical position of the front paper stop. Proceed as follows:

- Place a stack of about 50 sheets on the feed table.
- Switch on the pump.
- Start the machine (switch position I).

 **Exercise caution in the vicinity of rotating shafts and rollers!  
Hair, loose garments and jewellery may get caught!  
SERIOUS INJURY MAY RESULT!**

- By turning the knurled screw (6), adjust the vertical position of the paper stop in such a way that only one sheet is pulled off the stack.
- Switch off the machine (switch position 0).



## Setting the Sheet Gap

The sheet gap can be changed by means of a set screw (1).

This adjustment changes the speed of the suction drum, i.e. the gap between sheets is the result of the speed difference between feed drum and fold rollers.

- **Small gap between sheets:**

Turn the screw (1) all the way clockwise by means of a 2-mm Allen key.

For all parallel folds with the exception of letter fold in fold plate 1 and 2.

- **Large gap between sheets:**

Turn the set screw (1) all the way counter-clockwise by means of a 2-mm Allen key. To be used when the sheet length in the first fold plate is larger than half the length of the unfolded sheet (example: letter fold in fold plates 1 and 2).

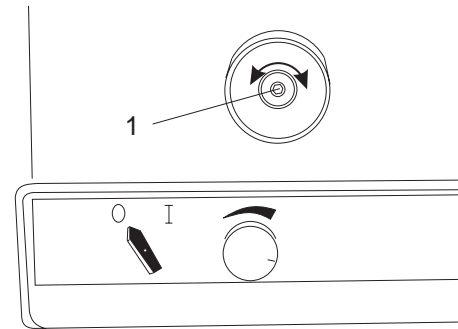

The feed speed has no influence on the speed of the fold rollers. Folding speed is set separately.

## Positioning the Paper Stack

- Fan the paper stack to avoid double sheets.
- Place the stack on the feed table (2).
- Position the rear paper stop (3). It prevents the paper from sliding off towards the rear.

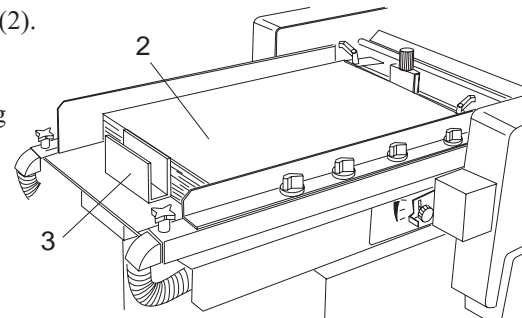

# 11. AIR FEEDER PBA 35

## Principle of Operation

The air feeder PBA 35 consists of a feeder and a register table.

It is suitable for handling a wide variety of papers - uncoated paper as well as coated, freshly printed or thin papers.

The sheets are separated by air and vacuum.

Air is supplied from the bottom of the stack both on the left and right side, separating the paper in the stack which now floats on a cushion of air.

A rotating suction drum can then separate the sheets from the bottom of the paper stack. This principle has the advantage that paper can be continuously reloaded with the machine running. There is no need to stop the machine.

## Description

Components and operating elements of the air feeder PBA 35:

- 1 Knobs and locking levers for adjusting the guide brackets
- 2 Air guide, left
- 3 Feed table
- 4 Air guide, right
- 5 Air-regulating valves
- 6 Front paper stop
- 7 Register table
- 8 Two-speeds adjustment
- 9 Locking lever for the suction segment
- 10 Lever for adjusting the suction segment
- 11 Operator panel / Counter
- 12 Rear paper stop

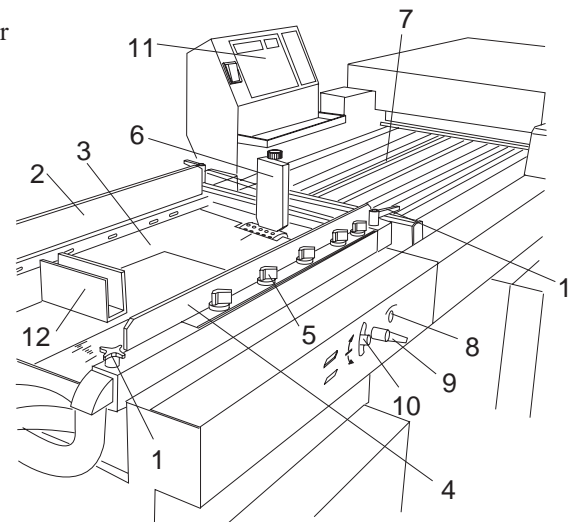

- 13 Register rail
- 14 Ball cage
- 15 Setting disk for changing the angle
- 16 Hold-down bars
- 17 Photodetector sheet gap control
- 18 Photodetector double sheet detection

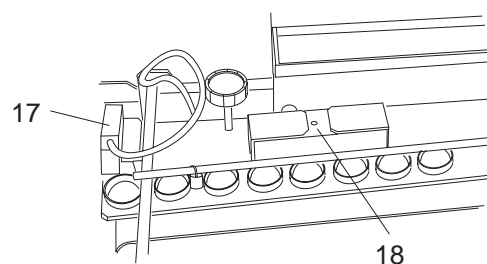
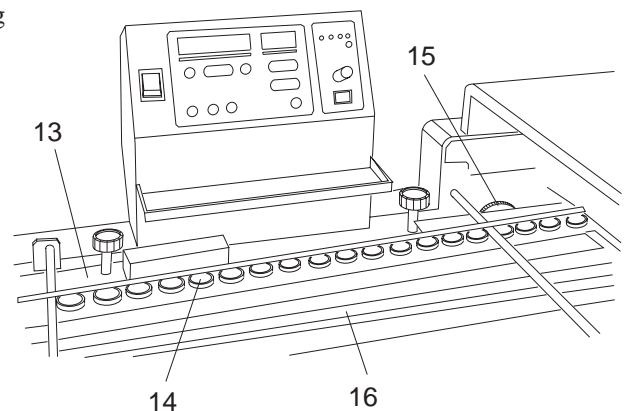

## Setting the Format



The paper should be positioned in such a way that it is fed approximately from the center.

- Loosen the knobs (1) by turning them counter-clockwise.
- Loosen the lock levers (2) by turning them counter-clockwise. They can be moved to a convenient position for tightening by lifting and then turning them.

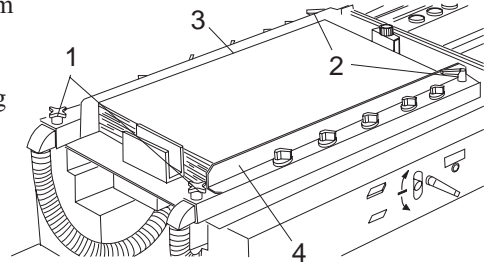

- Set the right air guide (4) to half the paper width with the help of the scale.
- Tighten the knob and the lock lever of the right air bracket.
- Place a paper stack of about 50 sheets on the feed table.
- Slide the left feed guide (3) against the stack.



Do not pinch the stack, leave at least 0.5 mm between paper stack and guide.

- Tighten the star knob and the lock lever of the left air guide.

## Setting the Sheet Separation

Sheet separation is achieved by the combined action of the rotating suction drum, the paper stop and the air.  
Paper weight and type of paper have an influence on the setting.

### Setting the air:

A suction drum (1) separates the sheets from the bottom of the paper stack. This is achieved by the suction segment (2) inside the suction drum. The angle of the suction segment with respect to the paper stop can be changed to suit the different types of paper.

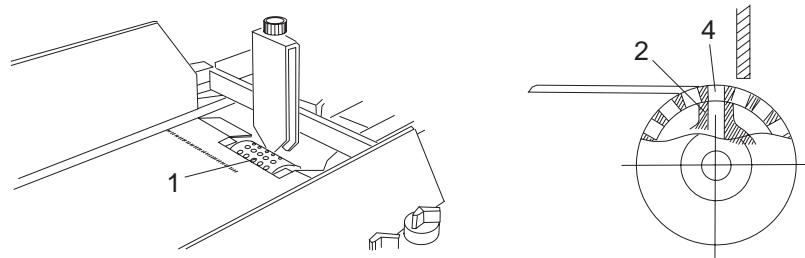

### Basic setting:

- By turning the handwheel, move the suction drum (3) to such a position that a row of suction holes is in the uppermost position (4) of the suction drum.

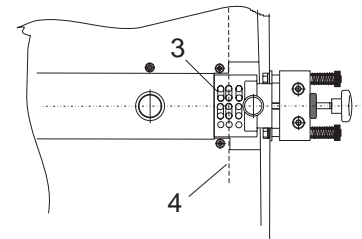

Proper adjustment can be checked as follows:

Place a sheet (5) against the edges of the cutout in the suction drum (6). This marks the centerline of the drum.

The sheet must cover the left half of the suction holes (7), while the right half (8) is still visible.

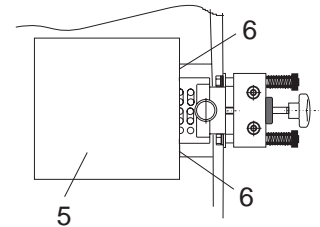

- Change the angle of the suction segment in such a way that the openings in the suction segment (9) line up with the next row of suction holes (10) in direction of paper travel.

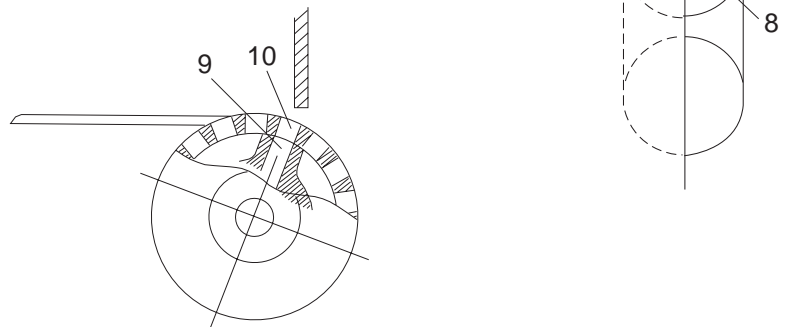

Set the suction segment as follows:

- Loosen the lock lever (1).
- Move the swivel lever (2) up or down, thus swinging the suction segment to the required position.  
Heavy paper grades: move swivel lever up  
Light paper grades: move swivel lever down
- Tighten the clamp lever by turning it clockwise.

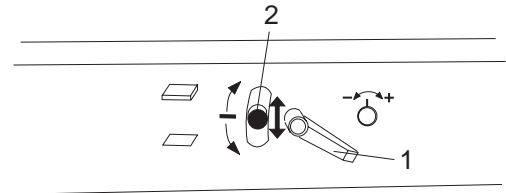

**Setting for light paper grades:**

Light paper grades easily cling to the curve of the suction drum. Therefore, the suction segment must be tilted in direction of the paper stop.

 For running light-weight paper, first try the setting as described under "Basic Setting".

The inclination of the suction segment in this direction has the effect that the paper is wrapped around the suction drum (3). The sheets are easily separated from the stack and double sheets occur very rarely.

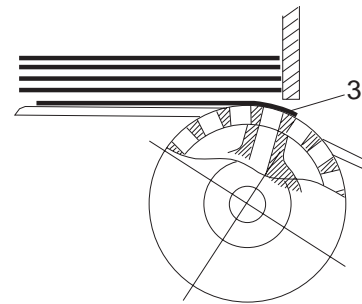

**Setting for heavy paper grades:**

Heavier paper grades do not cling easily to the curve of the suction drum. For this reason the suction segment must be tilted in direction of the paper stack.

The inclination of the suction segment in this direction has the effect that the paper is wrapped around the suction drum (1) very little. This is sufficient because heavier paper grades are more easily separated from the paper stack.

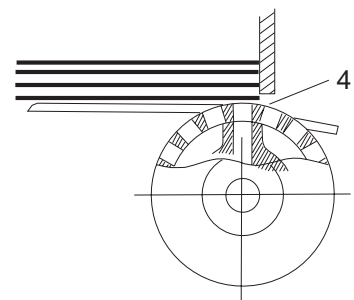

**Air:**

Open the valves (5) at both air brackets.

 In most cases it is sufficient to open the second and the last valve (with reference to the format length).

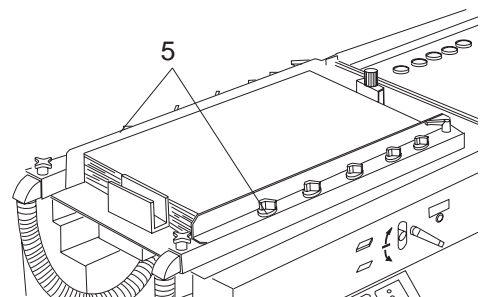
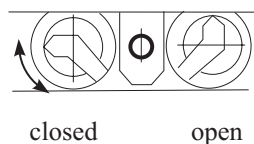

**Vacuum:**

Vacuum can be modified by means of a regulating valve (1). This is necessary because heavy paper grades require more vacuum than light paper grades..

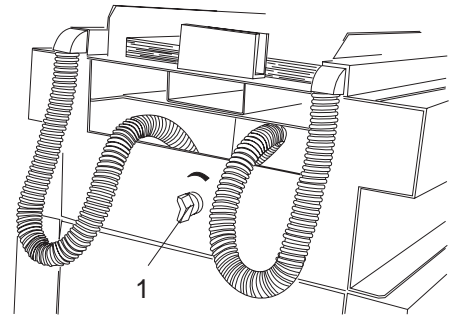

The vacuum can be modified by turning knob (1).

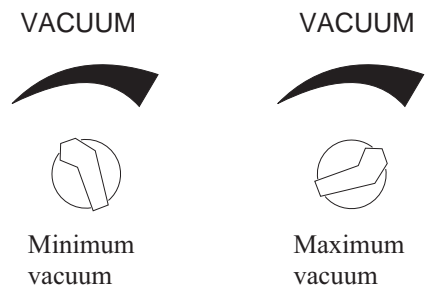

**Setting the vacuum**

For setting the vacuum, the machine must be turned on.

 **Exercise caution in the vicinity of rotating shafts and rollers! Hair, loose garments and jewellery may get caught! SERIOUS INJURY MAY RESULT!**

 **Do not get close to rotating shafts and rollers while the machine is running and the noise-absorbing cover is open! SERIOUS INJURY MAY RESULT!**

 **Exercise caution in the vicinity of the perforating- and slitting knives! They have sharp edges for proper function! SERIOUS INJURY MAY RESULT!**

- Close the valve for setting the minimum effect.
- Start the machine.
- Slowly open the valve by turning the knob clockwise. Observe the sheet separation while doing this.

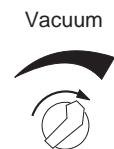
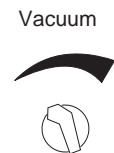

 At first no sheets are pulled off the stack or they are pulled off irregularly. The more the valve is opened, the smoother is the paper transport.

 Leave the knob of the valve in the position where even separation is obtained.

 Make sure that much vacuum does not cause feeding of double sheets.

- Switch off the machine.

**Adjusting the Front Paper Stop:**

The position of the front paper stop (1) can be adjusted in horizontal and vertical direction.

*Adjusting the horizontal position:*

The horizontal position of the front paper stop determines the suction point on the paper and in turn depends on the position of the suction segment in the suction drum.

 The inclination of the suction segment must be set correctly before making the horizontal adjustment.

 When the suction segment is adjusted, the horizontal position must also be changed accordingly.

- Turn the handwheel until the openings of the suction drum (2) are exactly above the openings of the suction segment (3).
- Adjust the horizontal position of the front paper stop in such a way that it forms a vertical line (4) with the leading edge of the suction openings. To achieve this, turn the knurled screw (5) counter-clockwise or clockwise.

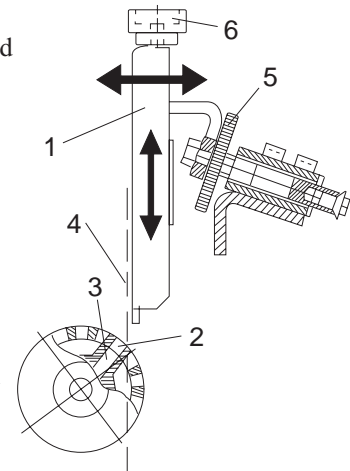
*Adjusting the vertical position:*

The respective paper thickness is set by adjusting the vertical position of the front paper stop. Proceed as follows:

- Place a stack of about 50 sheets on the feed table.
- Switch on the pump.
- Start the machine (switch position I).

 **Exercise caution in the vicinity of rotating shafts and rollers!  
Hair, loose garments and jewellery may get caught!  
SERIOUS INJURY MAY RESULT!**

- By turning the knurled screw (6), adjust the vertical position of the paper stop in such a way that only one sheet is pulled off the stack.
- Switch off the machine (switch position 0).

## Setting the Sheet Gap

The sheet gap can be changed by means of a set screw (1).

This adjustment changes the speed of the suction drum, i.e. the gap between sheets is the result of the speed difference between feed drum and fold rollers.

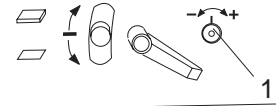

**Make the setting only with the machine turned off!**

- ***Small gap between sheets:***

Turn the set screw (1) all the way clockwise by means of a 2-mm Allen key. For all parallel folds with the exception of letter fold in fold plate 1 and 2.

- ***Large gap between sheets:***

Turn the set screw (1) all the way counter-clockwise by means of a 2-mm Allen key. To be used when the sheet length in the first fold plate is larger than half the length of the unfolded sheet (example: letter fold in fold plate 1 and 2).



The feed speed has no influence on the speed of the fold rollers. Folding speed is set separately.



On machines equipped with a batch counter, the sheet gap is set at the batch counter (see paragraph "Counters, Sheet gap in feeder"). If no sheet gap is desired (high speed stream feeding), i.e. when the operating mode "Without sheet gap control" is chosen at the batch counter, the sheet gap can be optimized by means of the set screw (1).

## Positioning the Paper Stack

- Fan the paper stack to avoid double sheets.
- Place the stack on the feed table (2).
- Position the rear paper stop (3). It prevents the paper from sliding off towards the rear.

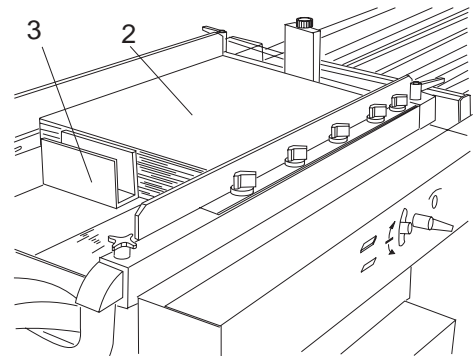



## Balls in the Register Table

The number and type of balls in the ball cage (1) depend on the format and the type of paper.



Always try to use as few balls as possible. Balls not needed for a particular job should be removed to avoid wear of the belts.

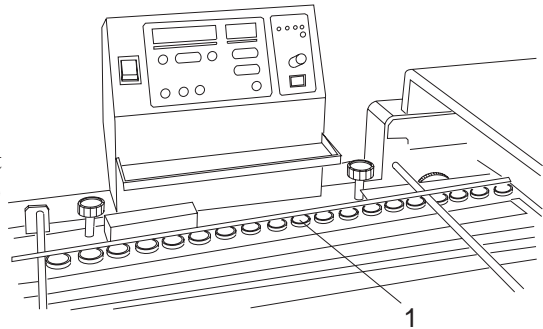

It is recommended to use the following balls:

- for paper grades below 60 GSM: Plastic balls
- for paper grades from 60 to 150 GSM: Plastic balls, every fourth should be a steel ball
- for paper grades above 150 GSM: Steel balls

In the infeed section (the first 4 to 6 balls), it is recommended to always use one or two steel balls.

For very light paper grades, every second ball opening should be left free.

# 12. BUCKLE FOLD UNIT 35/2 AND 35/4

## Description

Components and operating elements of the fold units:

- 1 Noise cover
- 2 Roller table
- 3 Handwheel
- 4 Adjustment for folding speed
- 5 On/Off switch

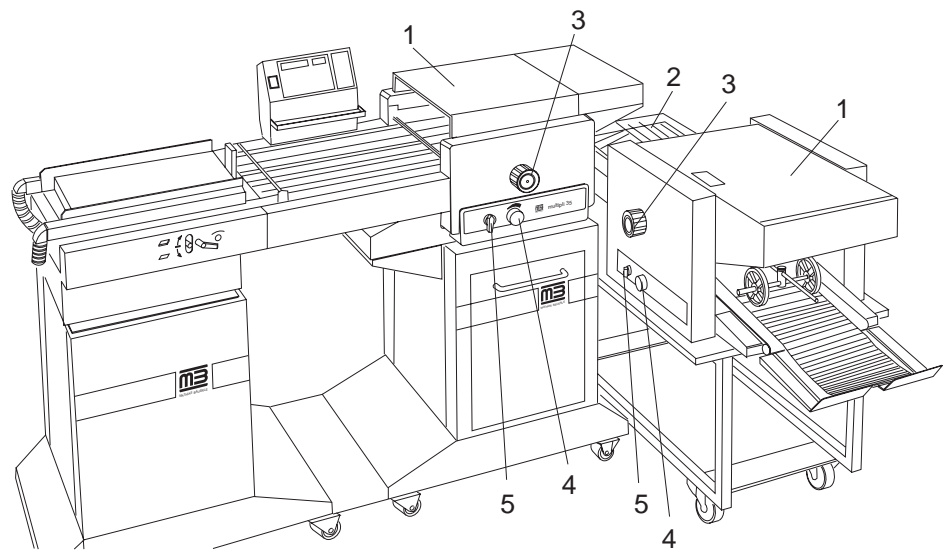

- 6 On/Off button (only on machines with two fold units)
- 7 Fold rollers
- 8 Delivery shafts
- 9 Ejector rollers
- 10 Transfer bridge (only for second fold unit and delivery A35)
- 11 Fold plates  
fold unit 35/2 = 2 fold plates  
fold unit 35/4 = 4 fold plates

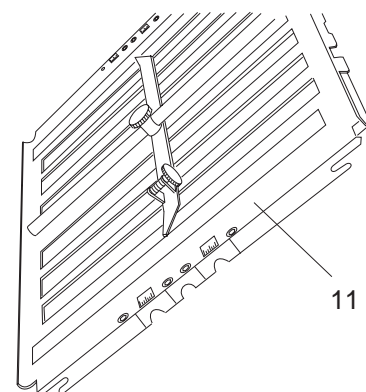
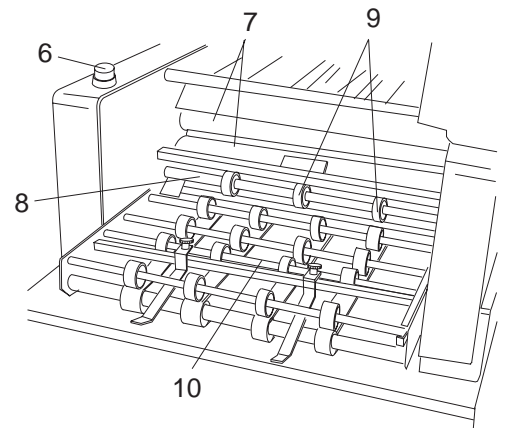

## Fold Plate Positions

In fold unit 35/2, there are two positions for the fold plates:

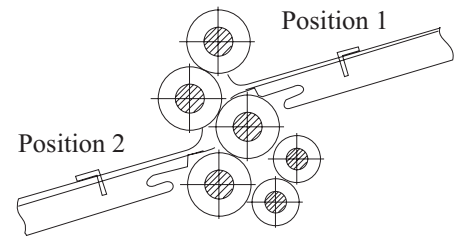

In fold unit 35/4, there are four positions for the fold plates:

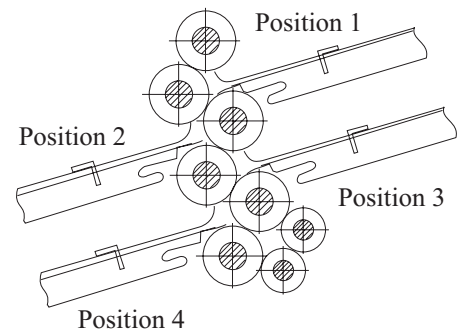

The fold plates are marked. When installing them, make sure that the fold plates are in the correct positions.

- Position 1: only fold plates marked "I"
- Position 2: only fold plates marked "II"
- Position 3: only fold plates marked "III"
- Position 4: only fold plates marked "IV"

Each fold plate has a deflector on its rear edge (1).

If a fold plate is not needed for a certain folding job, the respective position must be closed by inserting a fold plate with the deflector side pointing towards the fold rollers.

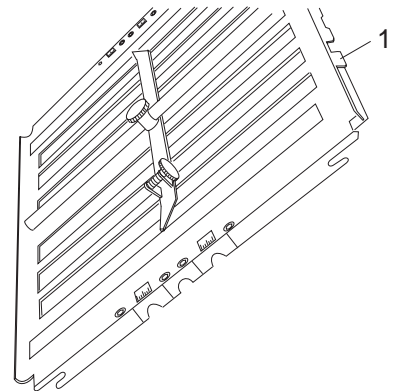

## Inserting the Fold Plates and the Deflectors

The fold plates must be inserted in such a way that two cutouts each (1, 2, 3, 4, 5) engage in the positioning pins which are located in the side panels of the fold unit.

Proceed as follows:

- Guide the fold plates with the mouth pointing forward (6) between the side panels of the fold unit. Cutouts (1) and (2) must engage in the positioning pins on the left- and right-hand side.
- If a fold plate is to be used as deflector, turn it by 180° and slide it between the side panels with the uninterrupted surface (7) pointing forward. Cutouts (4) and (5) must engage in the positioning pins on the left- and right-hand side.
- Check whether all pins are firmly engaged by turning the fold rollers by the handwheel.
- Cutout (3) is for inserting fold plates in machines which were built before March 1997. (Up to that date, the positioning pins were in different positions).

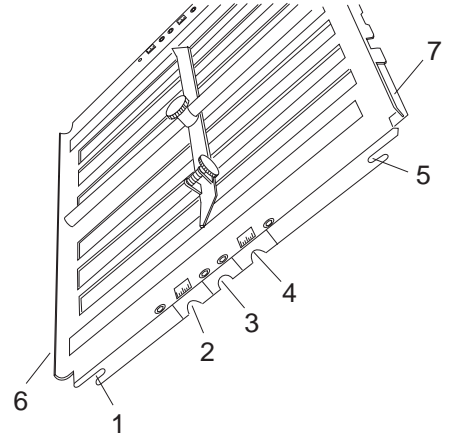

## Displacing the Fold Plates and Deflectors

There are special adjustment devices (8, 9) at the left- and right-hand side of the fold plates which make it possible to reduce the distance to the fold rollers, for example, when folding thin paper.

- Loosen the Allen screws on both sides of the fold plate (2.5 mm wrench).

 Set all 4 adjustment devices to the same measurement to make sure that the fold plate always has the same distance to the fold rollers, no matter whether it is used as fold plate or as deflector.

- Retighten the Allen screws.

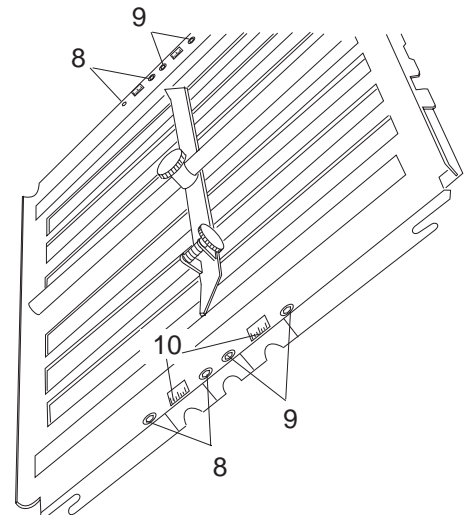

### Setting the Fold Plate Stops

- Loosen the fold plate stop by turning the knurled screw counter-clockwise (1).
- Set the stop to the required position on the scale (2).
- Secure the fold plate stop by turning the knurled screw clockwise.
- By turning a fine adjustment screw (3), the fold length can be adjusted precisely with the machine running
- Angle corrections for the paper stop are possible by turning the knurled screw (4).

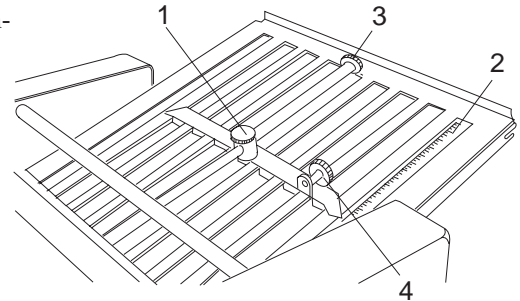

 The type of fold determines the position of the fold plates and of the deflectors. The original format determines the fold lengths to be set. The fold length is the distance between the fold plate stop and the fold line.

### Long Fold Plate LFT 35

A special fold plate (order no. 5.500.249) is available for longer formats. It is used when the first fold needs to be longer than 360 mm. The maximum fold length is 430 mm.

### Setting Guide for Common Types of Fold

On the following pages you will find a few examples on which fold plates and deflectors to use and how to set them:

Example:  
Letter fold

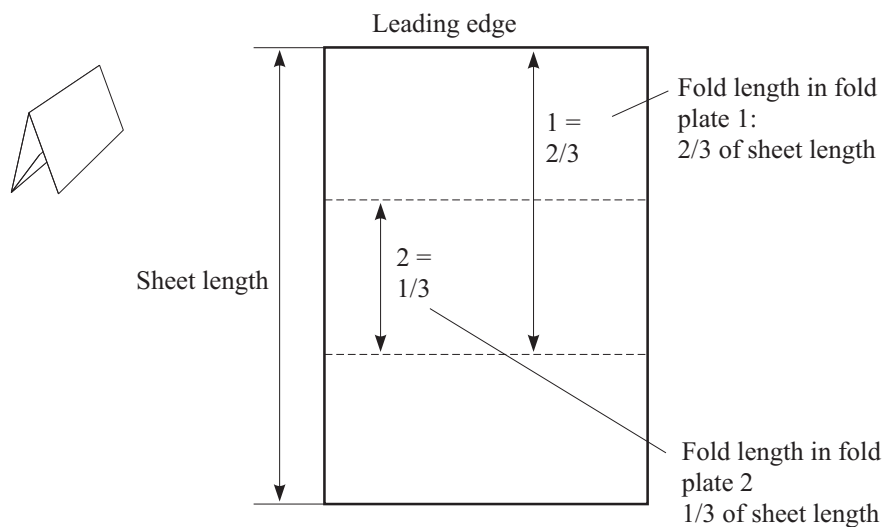

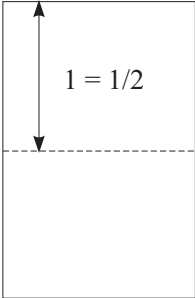
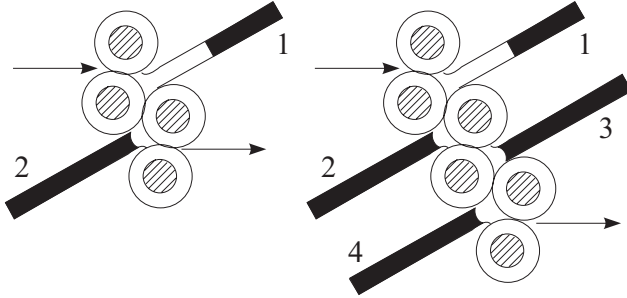
	Fold plate setting	Fold plate setting	
 Single fold			DIN A4 210 x 297 1 = 148 2 = 0 3 = 0 (35/4 only) 4 = 0 (35/4 only)
			DIN A3 297 x 420 1 = 210 2 = 0 3 = 0 (35/4 only) 4 = 0 (35/4 only)

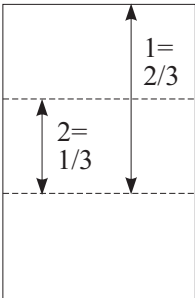
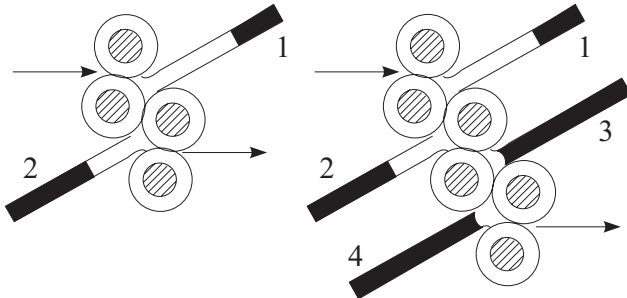
 Letter fold			DIN A4 210 x 297 1 = 198 2 = 99 3 = 0 (35/4 only) 4 = 0 (35/4 only)
			DIN A3 297 x 420 1 = 280 2 = 140 3 = 0 (35/4 only) 4 = 0 (35/4 only)

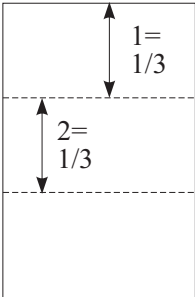
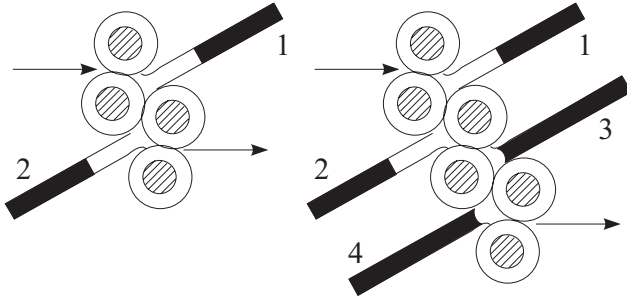
 Accordion ("Z") fold			DIN A4 210 x 297 1 = 99 2 = 100 3 = 0 (35/4 only) 4 = 0 (35/4 only)
			DIN A3 297 x 420 1 = 140 2 = 141 3 = 0 (35/4 only) 4 = 0 (35/4 only)

For accordion folds, fold plate stops should be set so they increase by 1 mm from one fold plate to the next.

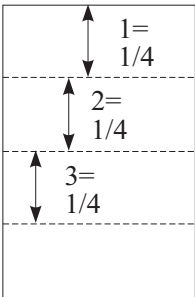
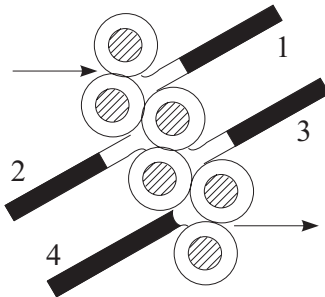
 8-page accordion fold			DIN A4 210 x 297 1 = 74 2 = 75 3 = 76 4 = 0
			DIN A3 297 x 420 1 = 105 2 = 106 3 = 107 4 = 0

For accordion folds, fold plate stops should be set so they increase by 1 mm from one fold plate to the next.

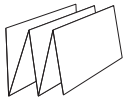
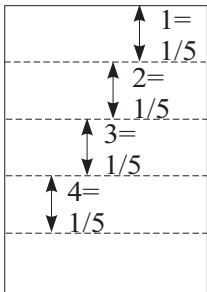
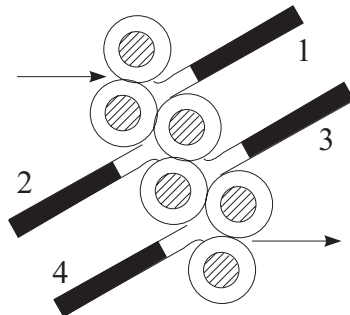
Type of fold	Fold length	Fold plate setting 35/2	Fold plate setting 35/4
 10-page accordion fold			DIN A4 210 x 297 1 = 59 2 = 60 3 = 61 4 = 62  DIN A3 297 x 420 1 = 84 2 = 85 3 = 86 4 = 87

For accordion folds, fold plate stops should be set so they increase by 1 mm from one fold plate to the next.

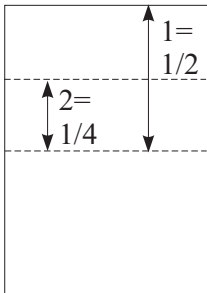
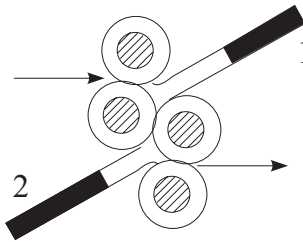
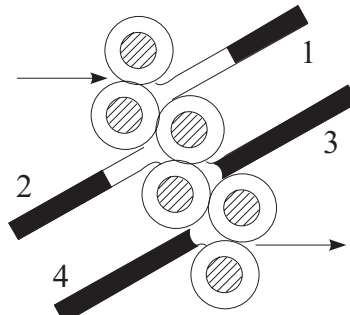
 Double parallel fold				DIN A4 210 x 297 1 = 148 2 = 74 3 = 0 (35/4 only) 4 = 0 (35/4 only)  DIN A3 297 x 420 1 = 210 2 = 105 3 = 0 (35/4 only) 4 = 0 (35/4 only)
--	--	--	---	---

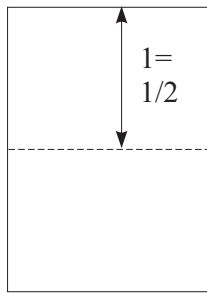
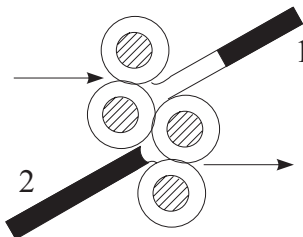
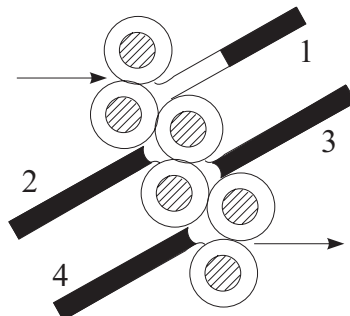
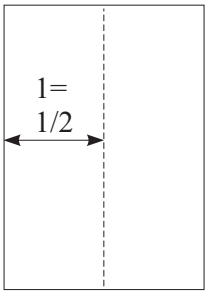
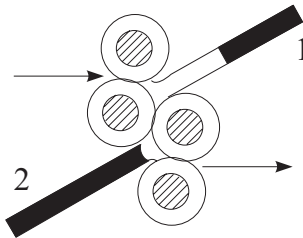
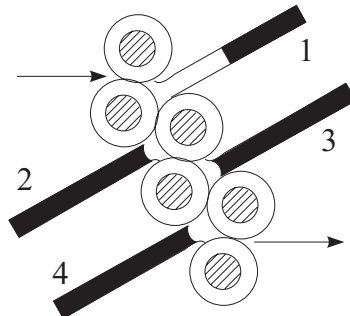
 Crossfold		 <p>1st fold unit</p>	 <p>1st fold unit</p>	DIN A4 210 x 297 1 = 148 2 = 0 3 = 0 (35/4 only) 4 = 0 (35/4 only)  DIN A3 297 x 420 1 = 210 2 = 0 3 = 0 (35/4 only) 4 = 0 (35/4 only)
		 <p>2nd fold unit</p>	 <p>2nd fold unit</p>	DIN A4 210 x 297 1 = 105 2 = 0 3 = 0 (35/4 only) 4 = 0 (35/4 only)  DIN A3 297 x 420 1 = 148 2 = 0 3 = 0 (35/4 only) 4 = 0 (35/4 only)

## Adjusting the Ejector Rollers

The ejector rollers on the delivery shafts must be set so that they are running on top of each other (1). An adjustment is only necessary when the sheets are no longer guided properly after a change of format. To adjust:

- Turn the handwheel until the set screws of the ejector rollers are visible (2).
- Loosen the screws (2) with a 2-mm Allen key.
- Shift the ejector rollers to the required position. Tighten the set screws.

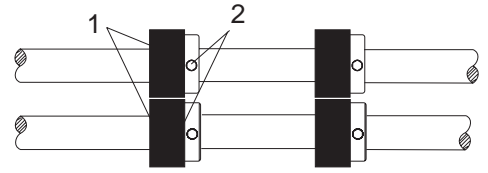

## Transfer Bridge

When a second fold unit is used, a transfer bridge (3) is attached to the delivery of the first fold unit.

When the bridge is used for the first time, check whether there is a drive gear (4) on the lower delivery shaft.

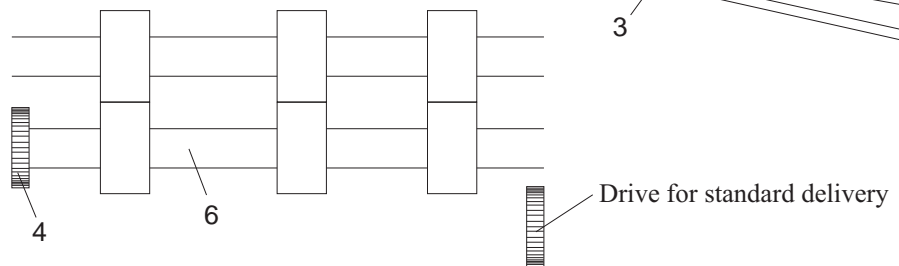
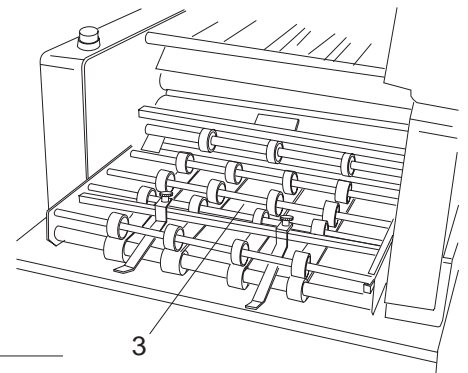

If it is not installed, proceed as follows:

- Loosen the two Allen screws (5) on the gear. The screws are secured against loss. Now it is possible to separate the two parts of the gear.
- Connect both parts of the gear on the lower ejector shaft (6).
- Connect the bridge (3). Make sure that the cutouts of the bridge are properly seated on the pins (7) and the crossbar (8).
- Check that the drive gear meshes with the gear of the bridge.
- Tighten the two Allen screws (5).

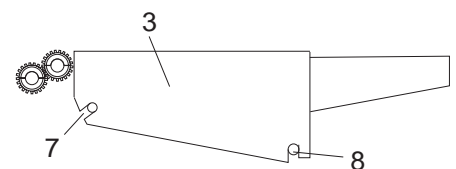
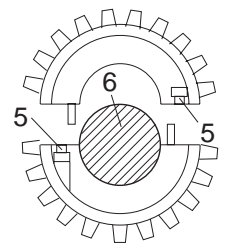



## Roller Table

On the roller table, the sheets are transported to the next fold unit by means of rollers which are positioned at an angle with respect to the register rail.

Proceed as follows when changing the format:

- Loosen the handle (1) by turning it counter-clockwise.
- Set the register rail (2) according to paper size.
- Tighten the handle by turning it clockwise.

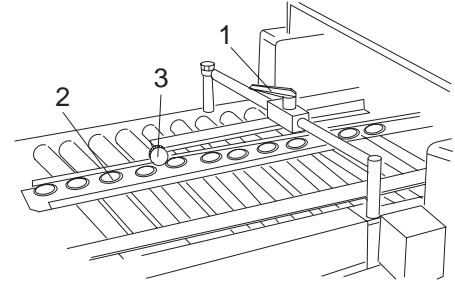

The alignment angle can be changed by turning the knurled screw (3).

The ball cage of the roller table must be equipped with plastic or steel balls. The type and number of balls depends on the format and the type of paper. A minimum number of balls should always be used. Balls not needed for a particular job should be removed to avoid wear of the belts.



It is recommended to use the following balls:

for paper grades below 60 GSM:

Plastic balls

for paper grades from 60 to 150 GSM:

Plastic balls, every fourth should be a steel ball

for paper grades above 150 GSM:

Steel balls



If the sheets are not aligned properly against the register rail and tend to skew, this can be corrected by means of adjustable ball cages (4).

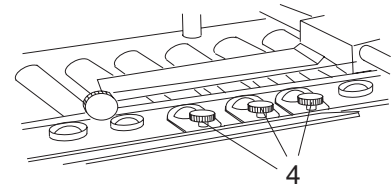

# 13. STANDARD FANNED DELIVERY

## Description

Components and operating elements:

- 1 Transport belt
- 2 Hold-down rollers
- 3 Knurled screw for hold-down rollers
- 4 Stacker plate
- 5 Knurled screws for adjusting the tension of the transport belts

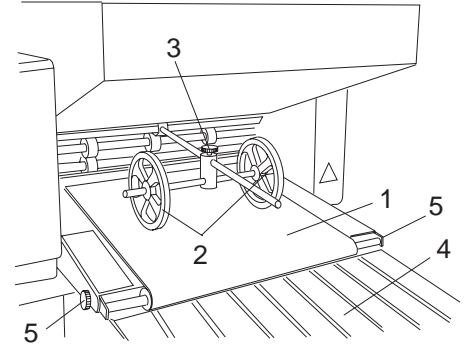

## Adjusting the Hold-Down Rollers

The hold-down rollers are needed for achieving a clean fanned delivery. They prevent the folded sheets from opening up on the delivery belt.

- Loosen the knurled screw (6) by turning it counter-clockwise.
- Shift the hold-down rollers in such a way that the distance (7) between delivery shafts and hold-down rollers corresponds to the final size of the folded sheet.
- Tighten the knurled screw by turning it clockwise.
- Shift the hold-down rollers sideways so that they are running about 5 cm from the left and right edges of the sheets.

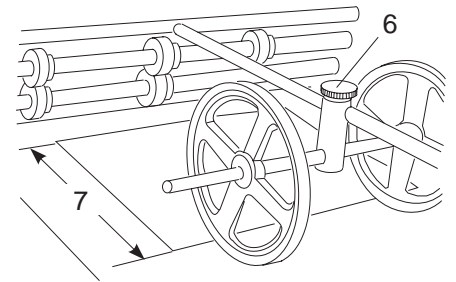

# 14. FANNED DELIVERY A 35

## Description

This type of delivery (order-no. 5.500.265) is equipped with an extended transport belt. This feature increases the capacity so there is more time between removing paper. The continuously adjustable drive permits a precise setting of the fanned delivery by means of a potentiometer.

Components and operating elements:

- 1 Transport belt
- 2 Potentiometer for belt speed
- 3 Stacker plate

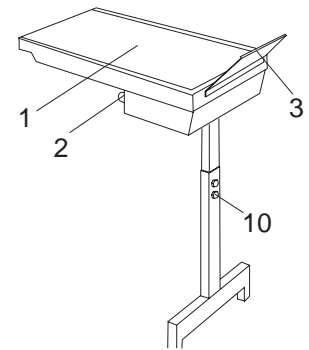

A transfer bridge (4) must be attached to the delivery end of the fold unit when working with a delivery A 35.

## Installation

When the bridge is used for the first time, check whether there is a drive gear (5) on the lower delivery shaft.

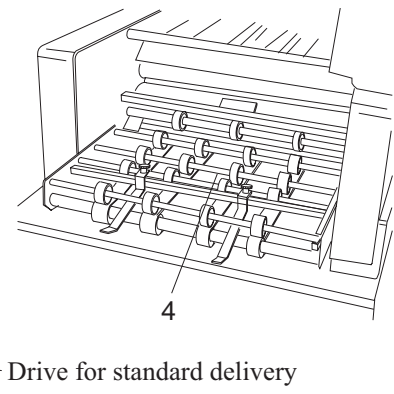
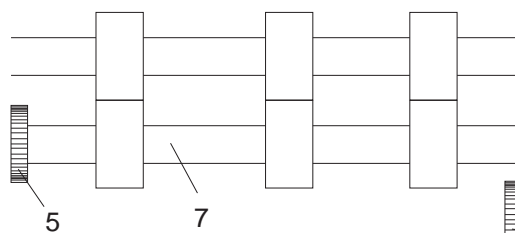

If it is not installed, proceed as follows:

- Loosen both Allen screws (6) of the gear - they are secured against loss. The gear can now be split into two sections.
- Connect the sections of the gear on the lower delivery shaft (7). Slightly tighten both Allen screws.
- Connect the bridge. Make sure that the cutouts of the bridge are properly seated on the pins (8) and the cross-bar (9).

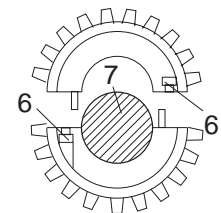

- Check that the drive gear meshes with the gear of the bridge.
- Tighten both Allen screws (6).
- Connect delivery A 35 to the cross-bar (9).
- Adjust the height of the foot by turning the setting screws (10).

## Adjusting the Hold-Down Rollers

The hold-down rollers are needed for achieving a clean fanned delivery. They prevent the folded sheets from opening up on the delivery belt.

- Loosen the knurled screw (1) by turning it counter-clockwise.
- Shift the hold-down rollers in such a way that the distance (2) between the delivery shafts and hold-down rollers corresponds to the final size of the folded sheet.
- Tighten the knurled screw by turning it clockwise.
- Shift the hold-down rollers sideways so that they are running about 5 cm from the left and right edges of the sheets.

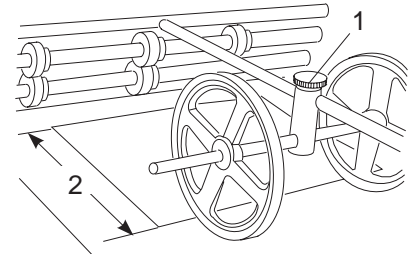



# 15. OPERATION AND TRIAL FOLDS

## multipli 35 F (Friction Feeder)

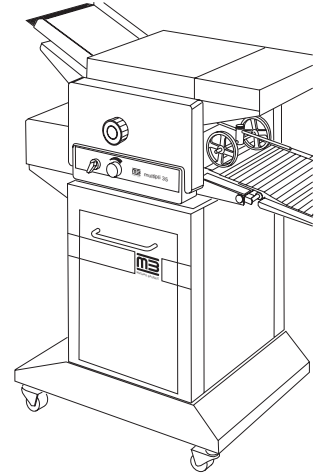
After all adjustments have been completed for a particular job, check the result by making a few trial folds. Make minor corrections using the fine adjustment knobs on the fold plates.



 **Exercise caution in the vicinity of rotating shafts and rollers! Hair, loose garments and jewellery may get caught! SERIOUS INJURY MAY RESULT!**

 **Exercise caution in the vicinity of the perforating- and slitting knives! They have sharp edges for proper function! SERIOUS INJURY MAY RESULT!**

 **Do not get close to rotating shafts and rollers while the machine is running and the noise-absorbing cover is open! SERIOUS INJURY MAY RESULT!**

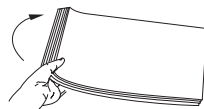

Place the properly fanned paper stack on the feed table.



Set the folding speed to medium speed.



If the machine is equipped with two fold units, the second fold unit must be set to a slower speed than the first fold unit.



Start the machine - switch position "I".



Machines with two fold units are equipped with a central On/Off switch. When both fold units are set to "I", the two fold units can be simultaneously switched on or off using this switch.

Make some trial folds.



Stop the machine - switch position "0".



It is good practice to interrupt the sheet feed before switching off the machine. This is done by pushing down the stack in the feeder with your hand to prevent sheets from being fed. Then turn the switch to "0".

Remove the trial folds and check the fold.





If the machine is equipped with a total counter, the count must be set to "0" by pressing the C key after the set-up of the machine has been completed.

**multipli 35 S  
multipli 35 PBA  
without Operator  
Panel**

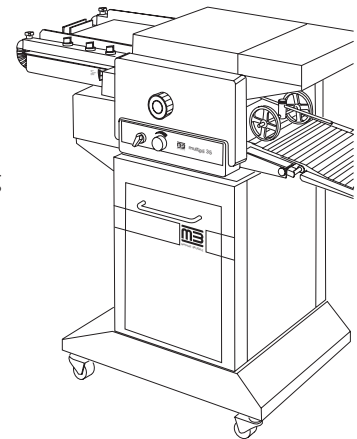
After all adjustments have been completed for a particular job, check the result by making a few trial folds. Make minor corrections using the fine adjustment knobs on the fold plates.



 **Exercise caution in the vicinity of rotating shafts and rollers! Hair, loose garments and jewellery may get caught! SERIOUS INJURY MAY RESULT!**

 **Exercise caution in the vicinity of the perforating- and slitting knives! They have sharp edges for proper function! SERIOUS INJURY MAY RESULT!**

 **Do not get close to rotating shafts and rollers while the machine is running and the noise-absorbing cover is open! SERIOUS INJURY MAY RESULT!**

Place the paper on the feed table.



Set the folding speed to medium speed.



If the machine is equipped with two fold units, the second fold unit must be set to a slower speed than the first fold unit.

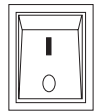

Turn on the pump by means of the switch on the cabinet.



Start the machine - switch position "I".



Machines with two fold units are equipped with a central On/Off switch. When both fold units are set to "I", the two fold units can be simultaneously switched on or off using this switch.

Make some trial folds.



Stop the machine - switch position "0".



It is good practice to interrupt the sheet feed before switching off the machine. This is done by pushing down the stack in the feeder with your hand to prevent sheets from being fed. Then turn the switch to "0".

Remove the trial folds and check the fold.





If the machine is equipped with a total counter, the count must be set to "0" by pressing the C key after the set-up of the machine has been completed.

## multipli 35 PBA with Operator Panel

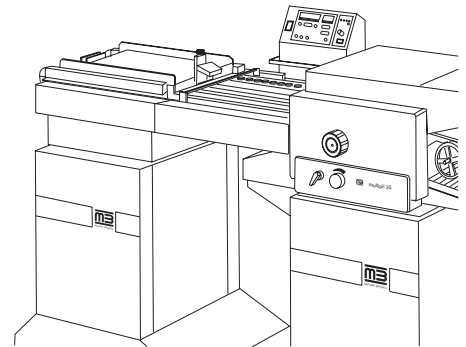
After all adjustments have been completed for a particular job, check the result by making a few trial folds. Make minor corrections using the fine adjustment knobs on the fold plates.



 **Exercise caution in the vicinity of rotating shafts and rollers! Hair, loose garments and jewellery may get caught! SERIOUS INJURY MAY RESULT!**

 **Exercise caution in the vicinity of the perforating- and slitting knives! They have sharp edges for proper function! SERIOUS INJURY MAY RESULT!**

 **Do not get close to rotating shafts and rollers while the machine is running and the noise-absorbing cover is open! SERIOUS INJURY MAY RESULT!**

Place the paper on the feed table.



Set the folding speed to medium speed.



If the machine is equipped with two fold units, the second fold unit must be set to a slower speed than the first fold unit.

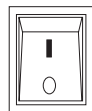

Turn on the pump by means of the switch on the cabinet.

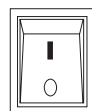

Switch on the operator panel.

Select the operating mode (see page 62).



Start the machine - switch position "I".



Machines with two fold units are equipped with a central On/Off switch. When both fold units are set to "I", the two fold units can be simultaneously switched on or off using this switch.



Press the "sheet feed" key - start of paper feed.

- Pressing the key briefly: single sheet feed
- Pressing the key for approx 2 sec.: continuous sheet feed

Make some trial folds.



Press the "sheet feed" key again - paper feed is stopped.

Remove the trial folds and check the fold.

# 16. FINE ADJUSTMENTS AND CORRECTIONS

## Fold Length

Fold variations may occur if the fold plate stops are not set accurately or if the folding speed is changed. The fold is off across the whole width of the sheets (as opposed to a skewed fold).

Corrections of the fold length are made by turning the fine adjustment screw (1).



A change in the folding speed also changes the fold length. Therefore the set-up speed must be maintained.

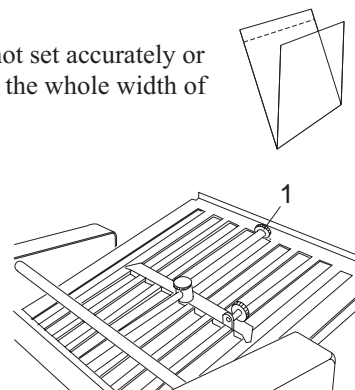

## Skewed Folds

Skewed (out-of-square) folds occur when the paper is fed not at right angles with respect to the fold rollers. This can be corrected as follows:

- Mark the leading edge of a sheet and feed it through the fold unit (2).
- To make the deviation more obvious, exaggerate the skewed fold by hand (3), (4).
- Open the folded sheet and place it in front of the roller infeed section (5).
- Correct, as shown on the following page.

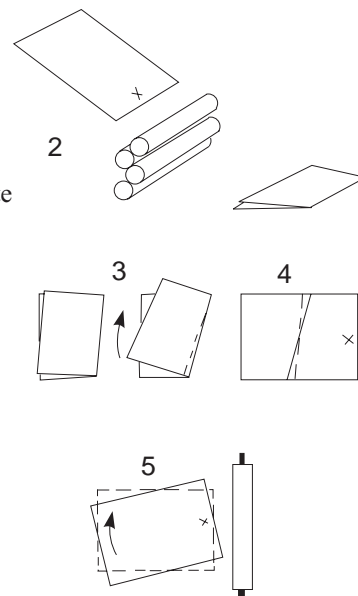



## Correction of Skewed Folds

### Machines with friction feeder F 35 or air feeder S 32:

Adjust the paper guides or air brackets on the feeder in such a way that the leading edge of the sheet is parallel to the fold rollers. (1).

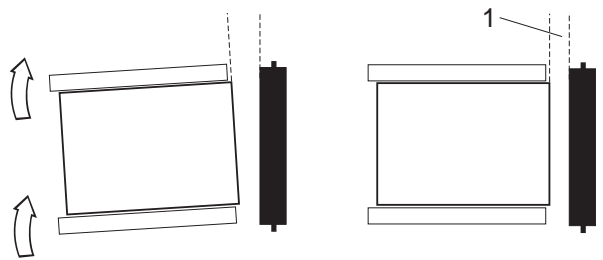

### Machines with air feeder PBA 35:

By turning the adjusting wheel (2), adjust the register rail in such a way that the leading edge of the sheet is parallel to the fold rollers.

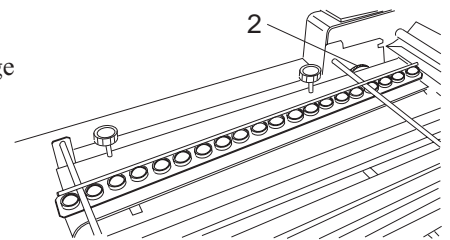

### Machines with roller table:

By turning the knurled screw (3), adjust the register rail of the roller table in such a way that the leading edge of the sheet is parallel to the fold rollers.

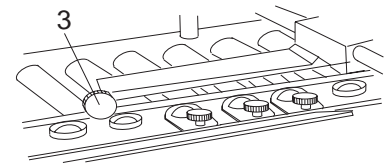

## Out-of-Square Paper

If the paper is not cut precisely at right angles, the folded sheets may show "points".



By turning a knurled screw (4), the fold plate stop can be adapted to the angle of the sheets.

- Turning the screw clockwise:  
The right side of the fold plate stop moves down.
- Turning the screw counter-clockwise:  
The right side of the fold plate stop moves up.

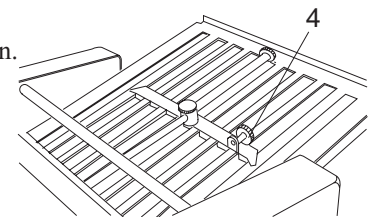

 Make this correction only on the first fold plate.

# 17. PERFORATING-, SCORING- AND SLITTING TOOLS

The following perforating-, scoring- and slitting tools are available:

- Perforating: standard, short      Order-no.      9.100.231  
                   standard, medium                      9.100.232  
                   blade, short                                      9.100.235  
                   blade, medium                                   9.100.236  
                   blade, long                                      9.100.237
- Scoring: narrow                      Order-no.      9.100.017  
                   medium    9.100.018  
                   wide    9.100.019
- Slitting                                      Order-no.      9.100.027



**Perforating- and slitting knives have sharp edges for proper function!  
 Exercise caution when removing and installing them!  
 SERIOUS INJURY MAY RESULT!**



**Before installing or removing scoring-, perforating- or slitting tools,  
 always PULL the power plug. This will ensure that no other person  
 will be able to start the machine while you are working on it.**

The perforating-, scoring- and slitting tools consist of an upper and a lower part, which have to be mounted on the upper resp. lower delivery shaft. The tools are split, therefore it is not necessary to remove the delivery shafts when exchanging the tools.

## Perforating

Purpose of perforating:

- To avoid creasing when making crossfolds.  
Air can escape from the folded sheet through the perforations.

Various perforating knives are available which differ in the type and number of teeth. Their usage is determined by the type of paper and the kind of perforating job.



Thin paper: short cuts, many teeth  
Heavy paper: long cuts, few teeth

There are two general types of perforations:

### 1.) Push-through:

Push-through perforations 9.100.231 and 9.100.232 run in the groove of a roller. Make sure that the perforating knife runs exactly in the center of the groove of its counterpart.

If the setting is not precise, this may lead to inaccurate perforations and premature wear of the tools.

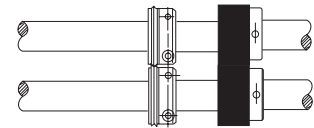
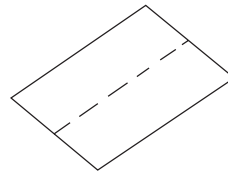

### 2.) Knife:

The counterpart of knife perforations 9.100.235, 9.100.236 and 9.100.237 is a rotary knife.

Position the upper and lower tools so that they touch each other lightly like the two knives of a pair of scissors.

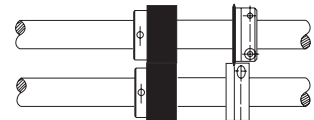
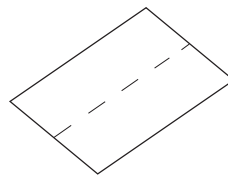

## Scoring

Purpose of scoring:

- To create of a hinge-type zone to aid the subsequent crossfold if the sheet cannot be perforated for functional reasons.

Scoring (1) is done with a male scoring wheel and a female counterpart. A groove is pressed into the paper when it passes between the tools. The texture of the material remains intact.

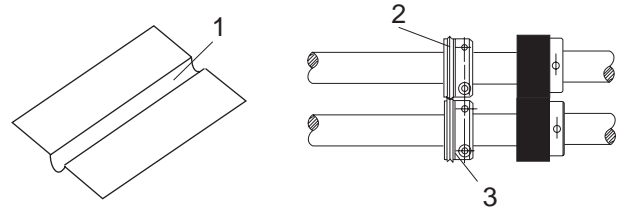

The male scoring wheel can be attached on the upper or lower ejector shaft, depending on the subsequent type of fold.

-  Upper ejector shaft: subsequent fold in fold plate 1 or 3
- Lower ejector shaft: subsequent fold in fold plate 2 or 4

Scoring wheels with different widths are available for scoring, depending on the paper thickness.

-  Thin paper: narrow scoring wheel
- Heavy paper: wide scoring wheel

-  The scoring disk (2) is used in conjunction with a grooved counterpart (3). Make sure that the scoring disk runs exactly in the center of its groove. If the setting is not precise, this may lead to inaccurate perforations and premature wear of the tools.

## Slitting

Purpose of slitting:

- Slitting, trimming and strip cutting.

An upper (5) and a lower knife (6) are required for slitting. The lower knife must be positioned close to the upper knife.

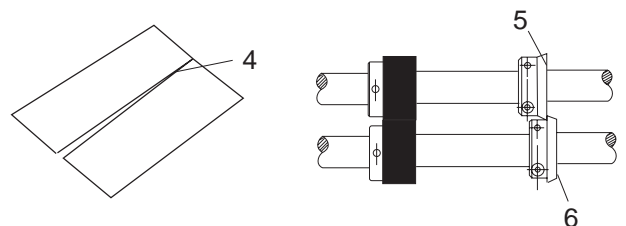

## Installation of the Tools

The guide rod of the hold-down rollers (1) and the square shaft (2) can be removed to improve the accessibility for installing the tools.

Proceed as follows:

- Pull the guide rod from the square shaft (1). The guide rod is attached with a leaf spring.
- Press the square shaft against the spring (3) at the side and tilt it out of the locating hole in the side plate.
- Install the hold-down rollers in reverse order.

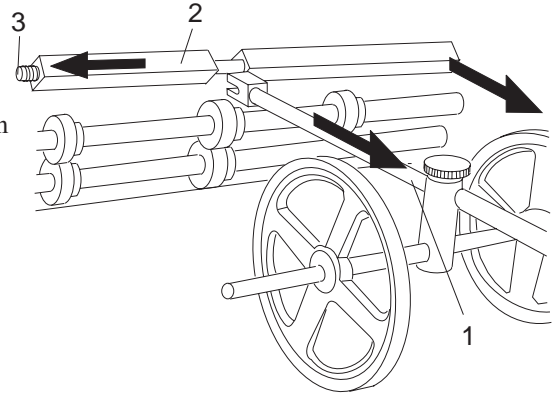

The perforating-, scoring- and slitting tools may be positioned anywhere on the ejector shaft. To determine the correct position, run an unfolded sheet through the fold unit by turning the handwheel and marking the correct position of the tool on the sample sheet.

The perforating-, scoring- and slitting tools are installed as follows:

- Loosen the two Allen screws (4) on the perforating-, scoring- and slitting tools. The screws are secured against loss. Now it is possible to separate the two parts of the tool.
- Connect both parts of the tool on the upper (5) and lower (6) ejector shaft.
- Slightly tighten both Allen screws.
- Slide the assembled tool to the exact location on the ejector shaft.

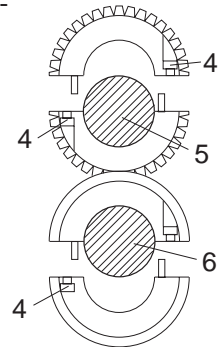

When perforating and slitting, the paper - especially light paper grades - may stick to the knife. Install a stripper (7) to prevent this from happening. The stripper should be located as close as possible without touching it.

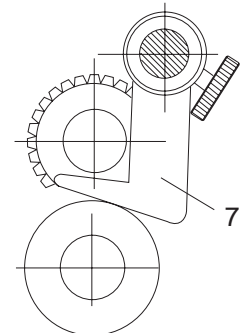

## 18. TOTAL COUNTER

An optional total counter (1) is available for folder models multipli 35 F, 35 S and 35 PBA. Retrofitting at a later date is also possible. The total counter permanently displays the number of folded sheets. It cannot be switched off. The display consists of 6 digits (2). The number shown can be reset by pressing the reset button (3).

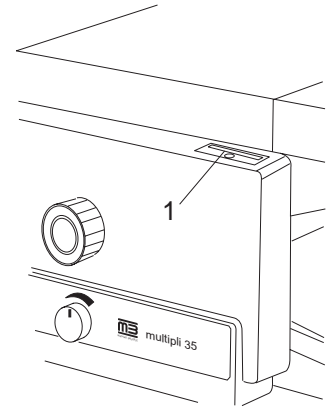
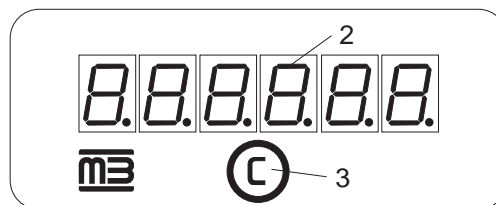

## 19. BATCH COUNTER

Folder model multipli 35 PBA can also be equipped with an optional batch counter. The purpose of this type of counter is to mark a pre-settable number of sheets (batch) by creating a gap in the fanned delivery, thus making it possible to separate the individual batches.

When removing the folded sheets from the delivery table, the batches will contain the same number of sheets.

Machines with a batch counter are equipped with a special operator panel (4) where the following functions can be set:

- Batch count
- Total count (resettable)
- Permanent count (non-resettable)
- Speed display
- Pulsed feed control
- Sheet gap control
- Paper travel control (at this time for the first fold unit only)
- Streamfeed
- Double sheet detection

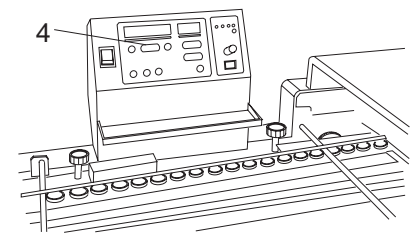

Two photodetectors are positioned on the register table:

- Photodetector for sheet gap control (5)
- Photodetector for double sheet detection (6)

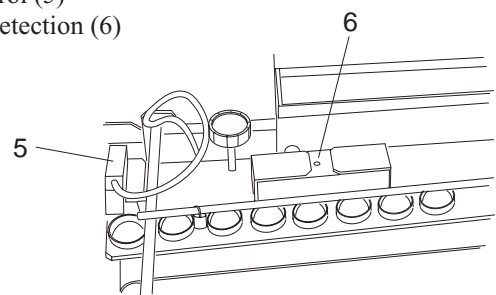

## Description

The operator panel is divided into several operating sections:

- A On/Off switch operator panel
- B Display and operating elements for pulsed feeding, sheet gap, total count, paper travel control
- C Displays and operating elements for batch counting
- D Double sheet detection

When switching on the machine, the batch counter is always in the operating mode in which it was before the machine was switched off.

This means that the preselected data are saved and that it is possible to start work immediately.

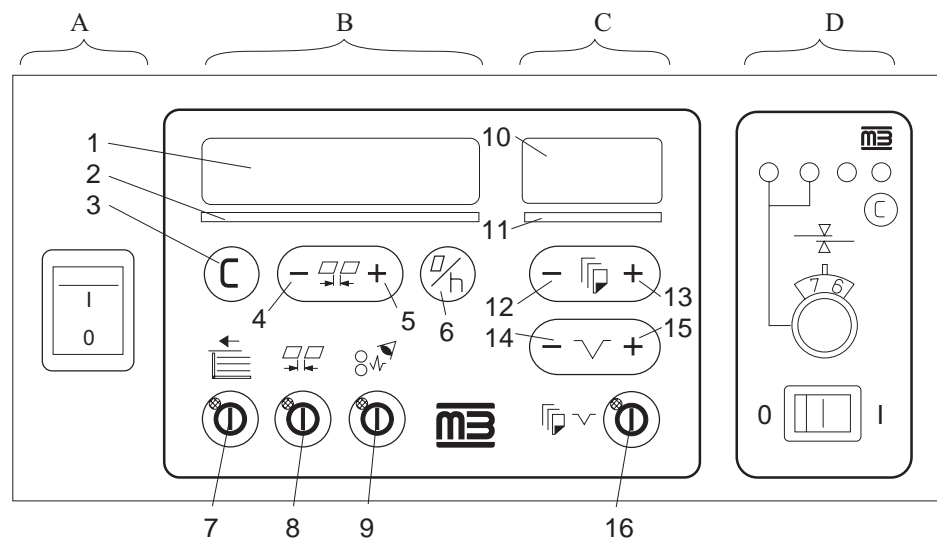

- |                   |   |
|-------------------|---|
| 1 Display         | Total count and speed display                             |
| 2 Analog display  | Sheet gap   |
| 3 Cancel key      | Clears the total count                                    |
| 4 Minus key       | Reduces the sheet gap                                     |
| 5 Plus key        | Increases the sheet gap                                   |
| 6 Mode key        | Switches from total count to speed display and vice versa |
| 7 On/Off switch   | Sheet feed  |
| 8 On/Off switch   | Control of sheet gap                                      |
| 9 On/Off switch   | Paper travel control                                      |
| 10 Display        | Batch count   |
| 11 Analog display | Interval time   |
| 12 Minus key      | Reduces the batch count                                   |
| 13 Plus key       | Increases the batch count                                 |
| 14 Minus key      | Reduces the interval time                                 |
| 15 Plus key       | Increases the interval time                               |
| 16 On/Off switch  | Batch counting  |

All sockets are located at the rear of the operator panel.  
The plugs are keyed to prevent incorrect connections.

The connections are as follows:

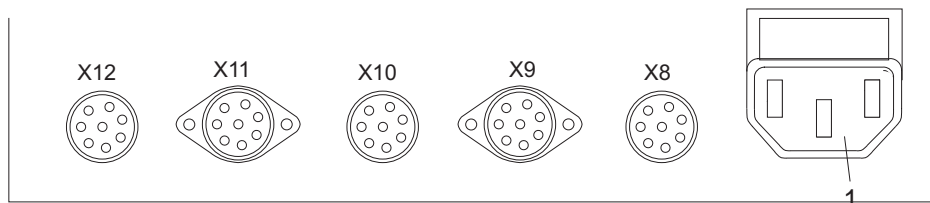

- 1 Line power socket
- X8 Solenoid valve
- X9 Pulsed photodetector
- X10 Double sheet detection
- X11 Counter photodetector
- X12 Paper travel control

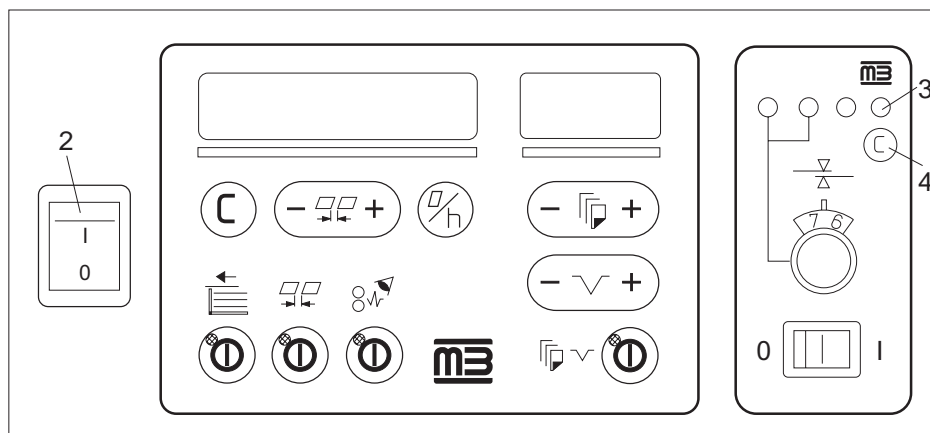

 Making adjustments on the operator panel is only possible when the main switch (2) is turned on.  
Press the reset key (4) when the red LED (3) is on in the double sheet detection section of the counter.  
The red LED will go out.  
Settings are possible only with the red LED out.



# Operating Modes

The control of the batch counter makes it possible to run the machine in different operating modes.

The LEDs in the keys indicate what mode is active at the moment.

## Continuous Suction Streamfeed

- **Without control of sheet gap, without batch counting**

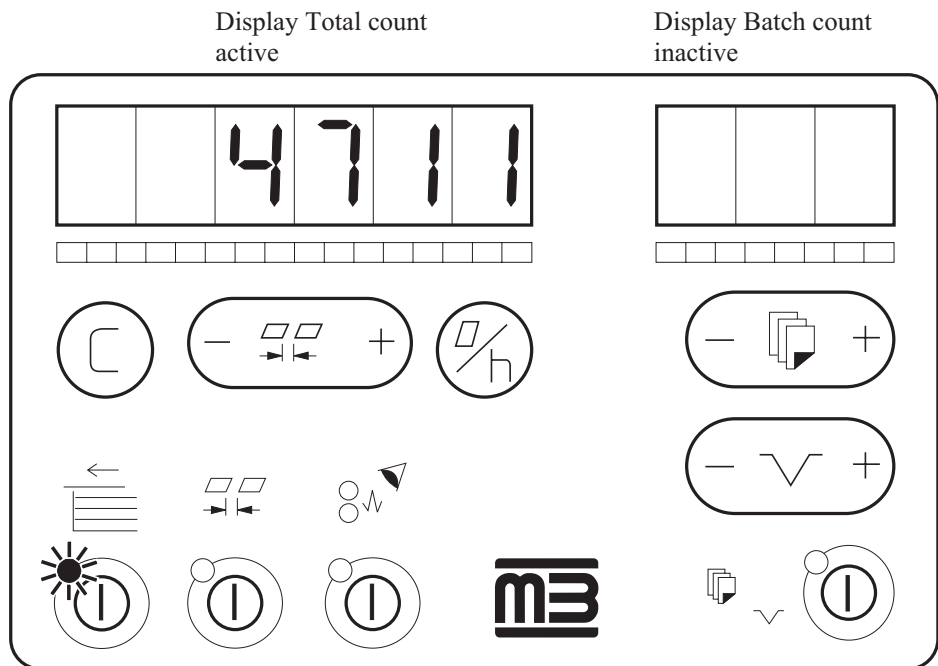

LED for sheet feed indicates ready state.

- **Without control of sheet gap, with batch counting**

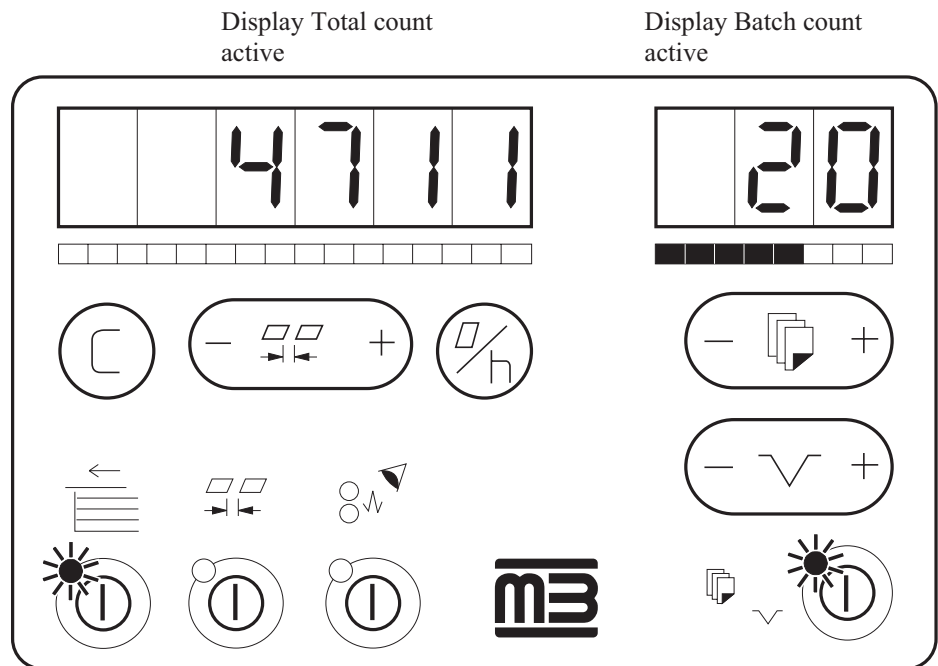

LEDs for sheet feed and batch count indicate ready state.

### Control of Sheet Gap

- **With control of sheet gap, without batch counting**

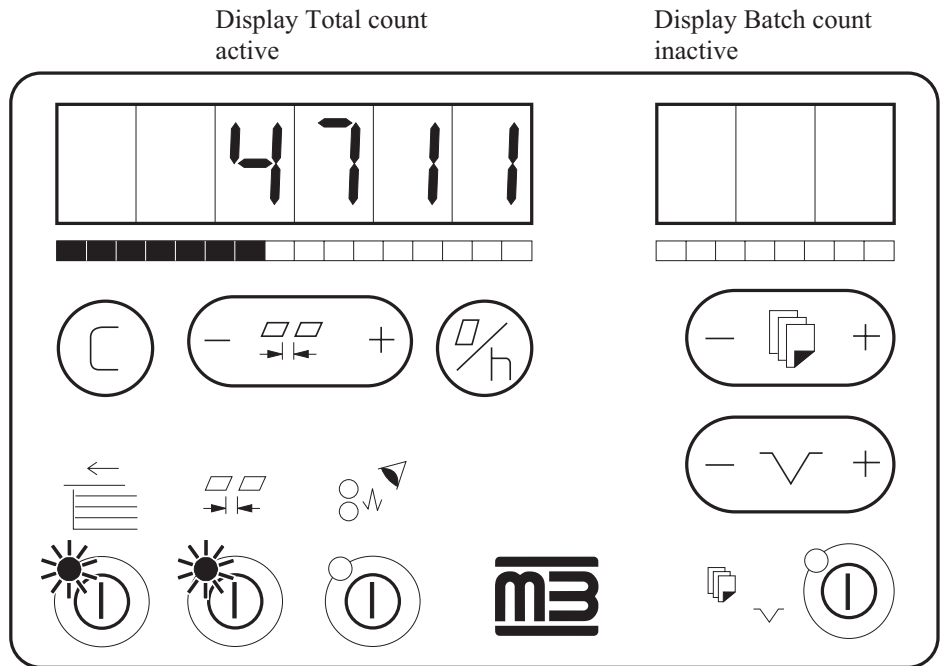

LEDs for sheet feed and control of sheet gap indicate ready state.

- **With control of sheet gap, with batch counting**

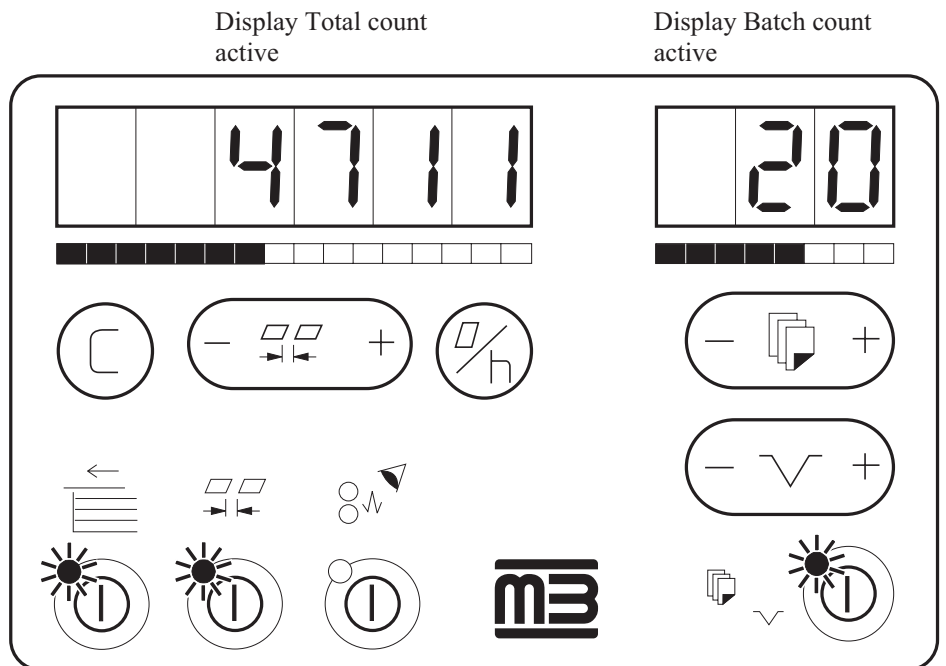

LEDs for sheet feed, control of sheet gap and batch count indicate ready state.

### Total Counter

The total counter which is integrated in the batch counter continuously shows the total number of folded sheets. It cannot be switched off.

The display consists of 6 digits.

To reset the total counter when starting a job or a partial job, push the keys in the following sequence:

*Key:*            *Explanation:*



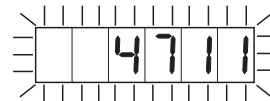

The figure remaining in the display from the previous job flashes for approx. 3 seconds. Push the key again during this length of time.



The display shows "0".



 The need for pushing key  twice prevents erasing the count by accident.

### Permanent Counter

The non-resettable permanent counter, which is integrated in the batch counter, is important for the service technician. This counter registers the total number of sheets which have been folded. The display is not permanently visible, it can, however, be called up by pressing a certain combination of keys. Proceed as follows:

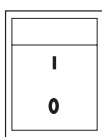

Turn off the main switch on the operator panel.

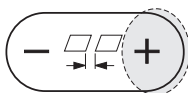



+

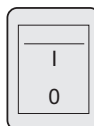

+



Simultaneously press keys  +  and turn on the main switch at the same time.

Since both segment displays are used for the non-erasable total counter, 9 digits can be displayed.

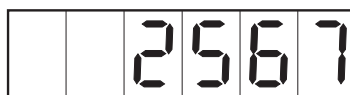

This display means: 2 567 345 sheets have been folded on this machine.

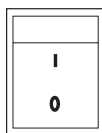





Turn off the main switch of the operator panel. Now the permanent display goes out.

# Setting the Batch Count

For batch counting, two settings are needed:

- the desired number of sheets per batch (preselection)
- the length of the gap between sheets (interval)

 Setting only one value will not enable batch counting.

The function of the batch counter can be switched on or off by pressing key   

## Switching on the Batch Counter

*Key:*                      *Explanation:*



The green LED indicates that the Batch Count setting feature is active.



The segment and the analog display come on.

## Setting the Desired Number of Sheets (one-up)

*Key:*                      *Explanation:*



Press the key several times until the correct number of sheets is shown in the display.



When working with a kicker, the smallest settable batch count is 10!

## Setting the Interval Time (Length of Sheet Gap)

*Key:*                      *Explanation:*



Press the key several times - the number of flashing LEDs in the analog display corresponds to a certain sheet gap.



Short interval:  
Only a few LEDs are on.



Long interval:  
Most LEDs are on.



When working with a kicker, the setting depends on the type of paper.

- Thin paper:            Only a few LEDs are flashing
- Thick paper:         Most LEDs are flashing



The interval can be changed with the machine running.

### Batch Counting for Two-up and Three-up

The batch counter can correctly count two- and three-up in a particular batch. To set, proceed as follows:

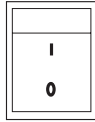

Turn off the main switch on the operator panel.

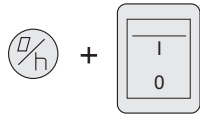

Press key  and turn on the main switch at the same time.

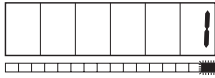

The display switches and indicates a number, for example "1".

The flashing LED indicates that the switch-over mode has been activated.

The numbers in the display stand for: 1 one-up  
2 two-up  
3 three-up



Using this key, set for one-up, two-up or three-up.



Pressing the plus-key increases the number to 3, pressing the minus-key reduces it to 1.

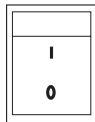

Turn off the main switch.  
The selected number is now saved.



The right LED is flashing continuously after the main switch has been turned on again. This indicates that the two- or three-up mode has been set.

If you want to check whether the batch counter has been set to one-up, two-up or three-up, just turn on the main switch. For a brief moment the display will show:

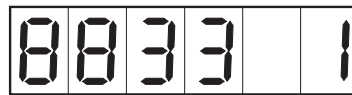

Program code

One-up, two-up or three-up

After a moment the display will automatically return to the total count displays.

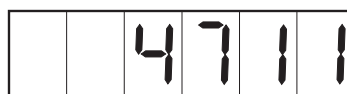

# Sheet Gap Control

The operating mode "sheet gap control" makes continuous sheet feeding possible in a predetermined rhythm. This allows to select a variable sheet gap.

The function of the sheet gap control can be switched on or off by pressing key .

## Switching On the Sheet Gap Control

*Key:*      *Explanation:*



The green LED indicates that the sheet gap set-up feature is turned on.

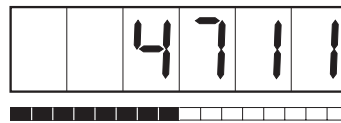

The analog display under the total counter comes on.

## Setting the Sheet Gap

*Key:*      *Explanation:*



Press the key several times - the number of flashing LEDs in the analog display corresponds to a certain sheet gap.

Small sheet gap:  
Only a few LEDs are on.



Large sheet gap:  
Most LEDs are on.



The sheet gap can be changed with the machine running.

# Speed Display

The current speed can be displayed with the machine running by pressing key .

The speed in sheets per hour appears in the 6-digit display while the key is pressed.

# Paper Travel Control

The paper travel control can be switched on or off by pressing key .

**ON:** LED is on      **OFF:** LED is off



The paper travel control is only active in the "pulsed" feed mode.

In case of a paper jam, paper travel is interrupted and the green LED in the  key is flashing.

Press key  after clearing the jam.

The LED comes on again and paper feed can be resumed.

# 20. DOUBLE SHEET DETECTION

The photodetector of the double sheet control recognizes when more than one sheet is fed from the stack at the same time.

If this is the case, paper transport is stopped.

The double sheet detection covers paper weights (offset quality) from 40 to 170 GSM.

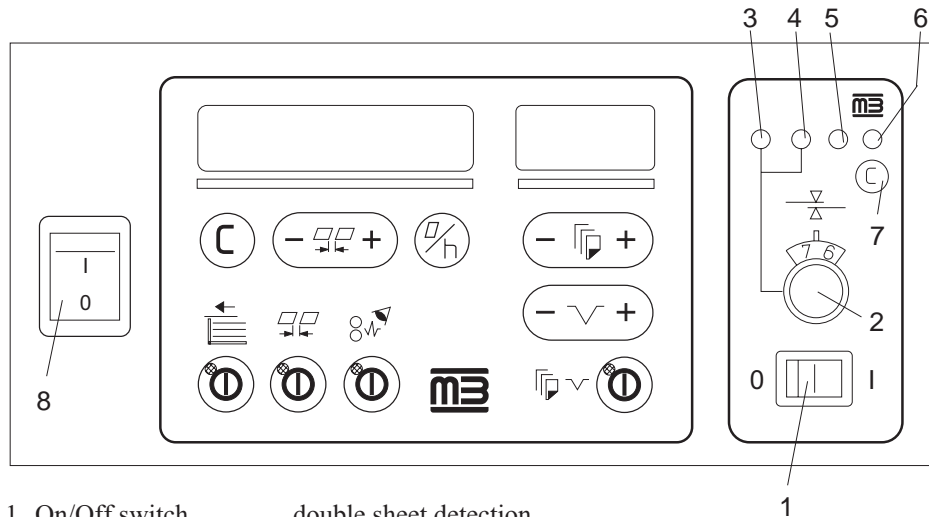

## Description

- |                 |  |
|-----------------|--|
| 1 On/Off switch | double sheet detection                   |
| 2 Knob          | for adjusting the double sheet detection |
| 3 LED, red      | setting aid                              |
| 4 LED, yellow   | setting aid                              |
| 5 LED, green    | indicates ready state                    |
| 6 LED, red      | indicates double sheets                  |
| 7 Reset button  | clears double sheet indication           |
| 8 On/Off switch | Operator panel                           |

## Setting

- Switch on the operator panel (8).
- Turn on the double sheet detection with switch (1). The green LED (5) indicates that it is ready for operation.
- Slide a folded sample sheet (an unprinted section) under the photodetector (9).

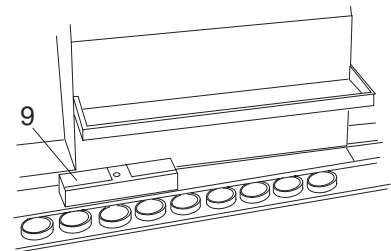

- Slowly turn the knob (2) to the left or to the right until:
  1. the green LED goes out
  2. the two red LEDs come on
  3. the yellow LED just comes on and is barely visible

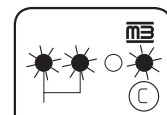

- Remove the double sample sheet.  
LED display: green LED is on  
red LED is on

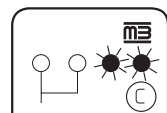

- Press key C.  
LED display: red LED goes out  
green LED is on

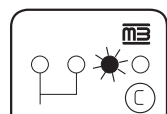

 If the double sheet detection is adjusted several times, the sample sheet must not stay under the photodetector. It must be placed anew under the photodetector every time an adjustment is made.

## Setting Check

- Fold a sample sheet once by hand.
- Slide the folded sheet under the photodetector.  
LED display: the two red LEDs are on  
the yellow LED is on

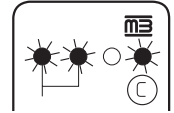

- Remove the paper.
- Press key C.  
LED display: the red LED goes out  
the green LED is on

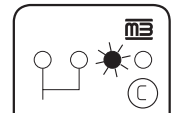



- Slide an unfolded sheet under the photodetector.  
LED display: the green LED is on

## Display of Double Sheets

 When the sheets pass under the photodetector, the red and yellow LED may come on briefly. This is normal and does not indicate a double sheet.

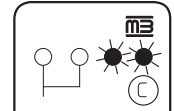
- When a double sheet is detected while the machine is running, the machine stops immediately.  
LED display: red LED is on  
green LED is on



 If the paper travel control  was activated, the green LED in this key may also come on.

- Remove the double sheet.
- Press key C.  
LED display: red LED goes out  
green LED is on

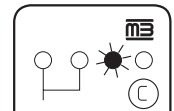

 Register belt and feeder start to work and transport the sheets which are still in the machine to the delivery section.

- Press the paper travel control key  when this LED is still flashing.

 Re-start feeding by pressing this key  .



## 21. TROUBLE SHOOTING GUIDE

<b>Problem:</b>	<b>see number.</b>						
Intermittent and irregular paper feed	1	2	3	4	5		
Creasing	2	6	7	8	9	23	24
Several sheets fed together	10	11	12	13			
Paper jam at the entrance into the fold plates	14	15					
No feed	16	17	18				
Out-of-square folds	19						
Points	20						
Fold variations	21	22					
Folded sheets run into each other	25	26	27				
Sheets not evenly fanned on delivery	26	27	28	29			
Folder does not run	30						
Sheet gap cannot be set although display indicates changes in sheet gap	31	32					

**No: Possible Cause:**

**Remedy:**

- |   |  |  |
|---|--|--|
| 1 | Guide bracket set too narrow                                   | Set with a little more side play                                 |
| 2 | Gap between feed- and pressure roller too narrow               | Increase gap with setting disk                                   |
| 3 | Infeed roller pressure insufficient or infeed roller worn      | Increase pressure with knurled nut on feeder or replace roller   |
| 4 | Hold-down pressure too high                                    | Slide the hold-down disks on the feed shaft outward somewhat     |
| 5 | Feed shaft drive belt worn                                     | Replace belt   |
| 6 | Infeed roller pressure too strong                              | Reduce with knurled nut  |
| 7 | Speed too high   | Reduce speed   |
| 8 | Paper runs at an angle   | Correct with guides  |
| 9 | Pressure of first pair of folding rollers too strong or uneven | Have pressure and parallel alignment set by our service engineer |

No:	Possible Cause:	Remedy:
10	Gap between feed- and pressure roller too wide	Narrow gap by turning setting disk
11	Paper stop is not set at the correct height	Change height by means of setting screw
12	Too much vacuum	Reduce vacuum
13	Air brackets are not set parallel	Adjust air brackets according to scale
14	Feed speed of suction drum too high	Set hand wheel to slow feed speed
15	Gap between sheets is too narrow	Adjust air flow. Move suction segment against the rotation of the suction drum
16	Pump is not switched on	Switch on pump
17	Suction drum is loose	Tighten suction drum (3 Allen screws)
18	Timing belt pulley is loose	Tighten timing belt pulley
19	Sheets are not fed at right angles	Align sheet guide on the feeder or right-angle table
20	Sheets are not cut at right angles	Adapt fold plate stop to the sheet by adjusting the knurled screw
21	Fold plate stop not set correctly	Readjust with fine adjustment screw
22	Change of fold speed	Set regular speed, check fold
23	Steel balls too heavy	Use plastic balls
24	Insufficient guidance by balls	Shift ball cages
25	Distance between ejector rollers and hold-down rollers too short	Increase distance
26	Ejector rollers on knife shafts are not distributed evenly across paper width	Arrange ejector rollers evenly across the paper width
27	Ejector rollers worn	Replace rollers
28	Paper feed irregular	Correct setting
29	Delivery belt is slack	Tension belt or replace, if necessary
30	Paper jam, safety system has switched off the machine	Clear jam, switch the machine off and then on again.

No:	Possible Cause:	Remedy:
31	Setting of sheet gap photodetector too sensitive or not sensitive enough. Red LED on photodetector is on continuously or not on at all	Using a screwdriver, reduce sensor sensitivity at potentiometer of sheet gap photodetector until LED goes out. Then check function of photodetector as follows: Place a paper strip under the detector: LED (red) comes on Remove paper strip from under the photodetector: LED (red) goes out
32	Sheet gap photodetector dirty	Clean bottom of photodetector with a soft cloth or a brush