

Premier® Heavy-Duty Paper Trimmers

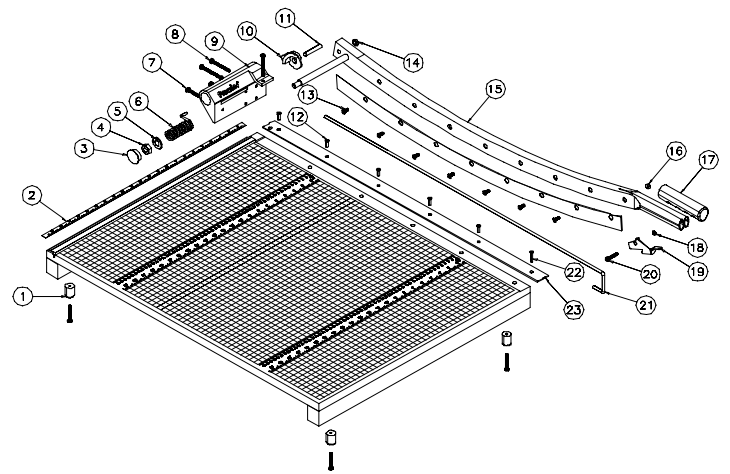

W30 PARTS LIST

Part Number	Description	Qty.	Part Number	Description	Qty.	Part Number	Description	Qty.
1 M-S030002	Bumper w/Recess	4	9 W-A017511	Prem. Lrg. Block	1	17 M-S043016	1" Hand Grip, Maroon	1
2 M-O017931	WX30/36 Ruler	1	10 M-O017654	Block Wear Pad	1	18 M-O017642	Latch Spacer	1
3 M-S016012	1 1/8 Hole Plug	1	11 M-S038006	5/16-18 X 1 3/4 SL Oval	1	19 W-O017652	Large Safety Latch	1
4 M-S007026	1/2-13 Hex Lock Nut	1	12 M-S004063	8 X 5/8 LR. W/#6 PH. F.H.	5	20 M-S001149	10-32 X 1.13 P/PH B/O	1
5 W-O001757	Torque Washer	1	13 M-S001020	10-32 X 1/2 Phil UC FH	7	21 W-O017550	30" Guard	1
6 M-S031053	Large Trimmer Spring	1	14 M-S007021	5/16-18 Jam Hex Nut	1	22 M-S004061	#8 X 1.25 Trim Hd. B/O	1
7 M-S004039	10 X 1.5 P/H Screw	7	15 W-A230101	Assy 30" Handle	1	23 W-O010530	30" Straight Blade	1
8 M-S004050	10 X 2 PH. P/H Screw	3	16 M-S007033	Hex Acorn Nut, 10-32	1			

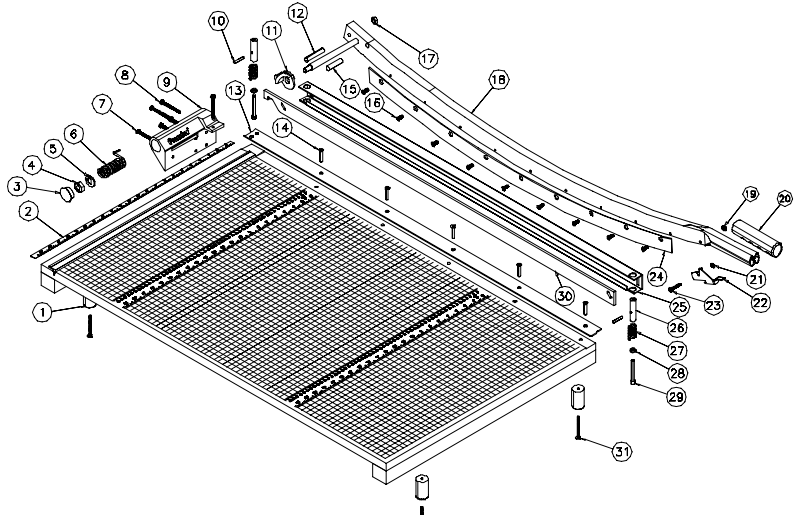
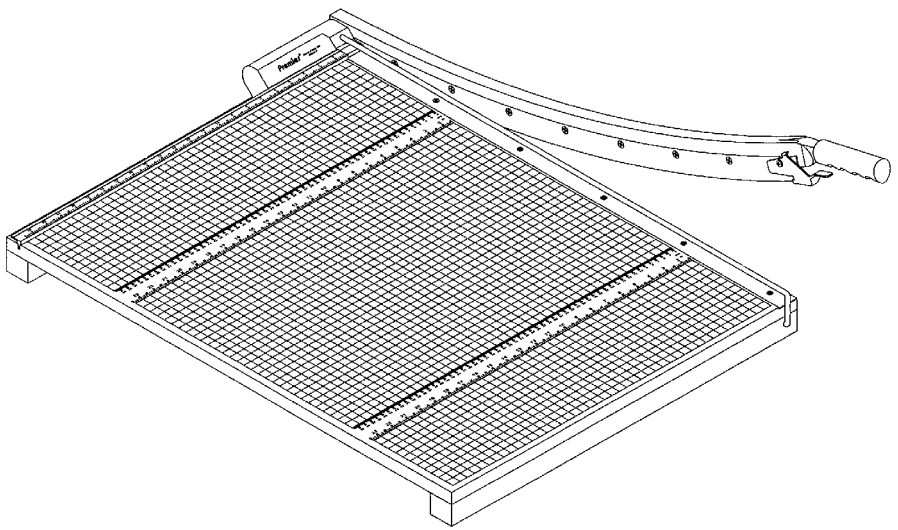

WC36 PARTS LIST

Part Number	Description	Qty.	Part Number	Description	Qty.	Part Number	Description	Qty.
1 M-S030045	755 RW Bumpers	4	12 M-S038002	3/8-24 X 2 Set Screw	1	23 M-S001149	10-32 X 1.13 P/PH B/O	1
2 M-O017931	WX30/36 Ruler	1	13 W-O236111	36" Stralght Blade	1	24 W-O236115	36" Curved Blade	1
3 M-S016012	1 1/8 Hole Plug	1	14 M-S004017	#10 X 1.25 AB PFH	5	25 W-O017336	36" Clamp Bar, Maroon	1
4 M-S007026	1/2-13 Hex Lock Nut	1	15 M-S018041	3/8 X 1 1/2 Roll Pin	1	26 M-O017636	Guide Pin	2
5 W-O001757	Torque Washer	1	16 M-S001020	10-32 X 1/2 Phil UC FH	9	27 M-S031024	Clamp Spring	2
6 M-S031053	Large Trimmer Spring	1	17 M-S007023	5/16-18 Jam Hex Nut	2	28 M-S008025	1/4 X 5/8 F/Washer	2
7 M-S004039	10 X 1.5 P/H Screw	3	18 W-A236110	Assy 36" Handle	1	29 M-S003083	1/4-20 X 2 1/2 SHCS	2
8 M-S004050	10x2 PH RD Lo-Root	3	19 M-S007033	Hex Acorn Nut, 10-32	1	30 W-O236112	Rlser Bar	1
9 W-A017511	Prem. Lrg. Block	1	20 M-S043016	1" Hand Grip, Maroon	1	31 M-S004026	10 X 2-1/2 PPH Screw	4
10 M-S018004	3/16D X 1 Lg Rollpin	2	21 M-O017642	Latch Spacer	1			
11 M-O017654	Block Wear Pad	1	22 W-O017652	Large Safety Latch	1			

Key Features and Benefits

- Heavy-duty 3/4" thick wood base
- Fully-hardened self-sharpening steel blades cut up to 20 sheets
- Accurately cuts paper, matte board, cardboard, film, tissue, and textiles
- Permanent 1/2" grid and dual rulers for proper paper alignment
- Patented automatic blade latch locks with every cutting motion
- Finger guard helps protect the entire blade length
- Torsion spring counterbalances blade arm
- Non-skid feet

Model Numbers

W30 – 30" cutting length
WC36 – 36" cutting length

MADE IN USA

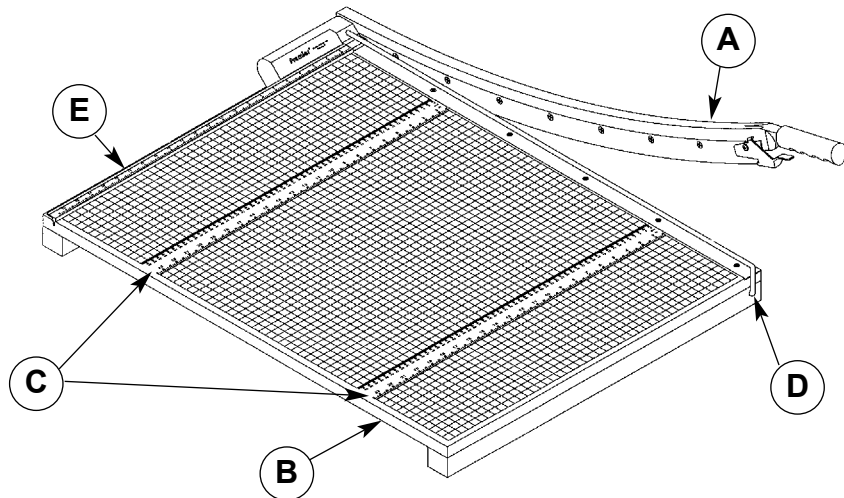

Key Components

- A – Hand Grip/Blade Arm/Blade Latch Assembly
- B – Wood Base
- C – Alignment Rulers
- D – Finger Guard (*note model WC36 has a automatic clamp in place of the finger guard*)
- E – Paper Guide Ruler

Assembly Instructions

None – your trimmer is ready for use right out of the box

Automatic Safety Latch

The patented automatic blade latch is a key safety feature of this trimmer. It will lock with every complete cutting stroke, helping to eliminate forgetfulness. Remember to always push the blade arm down completely when you are finished cutting, to ensure that the latch activates. Never remove the latch for any reason.

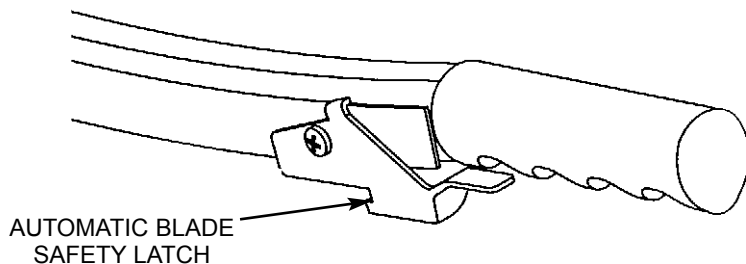

Operating Instructions

1. Place the trimmer on a flat, stable surface
2. Release the blade latch, which is located on the hand grip (A)
3. Lift the blade arm (A) up into cutting position
4. Using the rulers or the 1/2" grid, align the paper to the proper position, pushing it up against the paper guide ruler (E).

CAUTION:

Keep hands and fingers behind the finger guard (D) at all times, away from the cutting blades

5. While holding the paper down with your left hand (to make sure it stays in place), pull down the blade arm (A) to cut. Model WC36 has a clamp that will automatically activate to assist in holding the paper in place.
6. Always make sure that the blade arm is completely down and locked when not in use.

Safety Information

- Always ensure that the blade arm is fully pushed down, and that the blade latch is engaged, when not in use
- Never operate the trimmer without the finger guard in place
- Always keep clothing, jewelry, watches, and hair away from the cutting blade
- Keep out of the reach of children
- Do not carry the trimmer by the hand grip or the blade arm

For Best Cutting Performance

Use Trim-Ease Blade Lubricant for a smoother cut and to help preserve the life of the cutting blade. To order, send \$4.00 per stick and a self-addressed, stamped envelope to the address below.

Customer Service

Telephone: (260) 563-0641
Fax: (260) 563-4575
Email: info@martinyale.com
Internet: www.martinyale.com
Address: Martin Yale Industries, Inc.
 251 Wedcor Avenue
 Wabash, IN 46992

Visit www.martinyale.com for more information on trimmers and other office products.