



The **AutoSeal 2200-10** stand-alone pressure sealer is the ideal solution for high-volume mailers who want to utilize existing floor model folding systems. The ability to purchase a “sealer-only” system versus a complete folding and sealing solution drastically reduces the up-front capital needed to add pressure seal as a new solution for your customers.

The 2200-10 utilizes a patented pressure seal system that has been carefully engineered and refined to process pressure seal forms at speeds of up to 40,000 pieces per hour in the most demanding environments.



FD 2200-10 shown in-line with folder.

### Standard Features

**Stand-Alone Sealing System:** Specifically designed for use with various high-production floor model folders

**Heavy Duty Construction:** Designed for high-volume production environments such as direct mail and fulfillment centers

**Pressure Rollers:** High-production precision ground clutching four-roller system

**Fault Detection:** Infrared sensor located at the infeed of the sealer detects any faults and sends signal to stop the upstream folder it's connected to

**Clutching Roller System:** Clutching roller system reduces belt and motor wear when double-feeds are detected

**Safety Cover Interlock:** Shuts down the system when the cover is open

**Static Eliminator:** Static brush is located on the exit of the sealer to reduce static electricity and assist in the neat, sequential stacking of forms onto a conveyor

**Interface Connections:** Three interface connections for power input, signal input and fault detection output

**Plexi-Cover:** Allows operators to watch forms pass through the sealer. The cover is hinged with a handle to allow quick access to the sealing area.

**8-Ball Transport Deck:** 10” ball-deck provides smooth, enclosed transport of the form from the folder rollers into the sealer

**Heavy-Duty Casters:** Adjustable height - 2 fixed locking casters, 2 swivel casters

**Mounting Bracket:** Securely attaches the FD 2200-10 sealer to the folder

### Side view

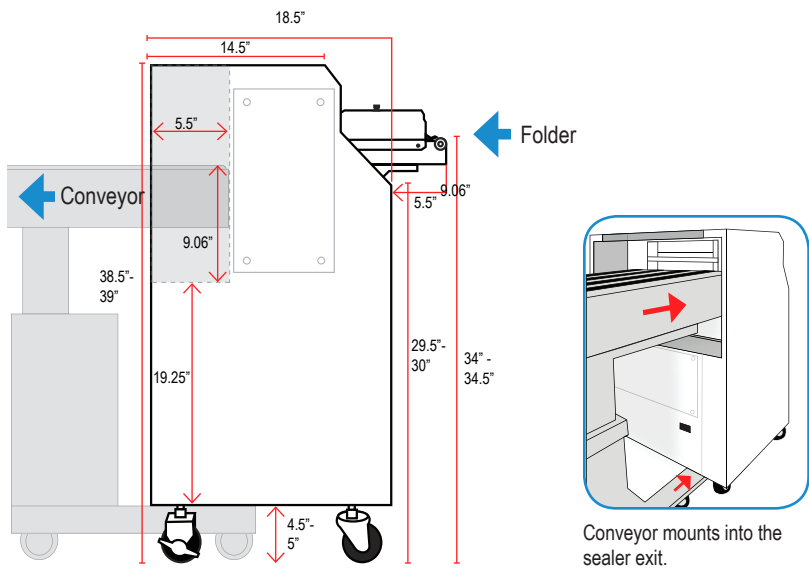

### Rear view

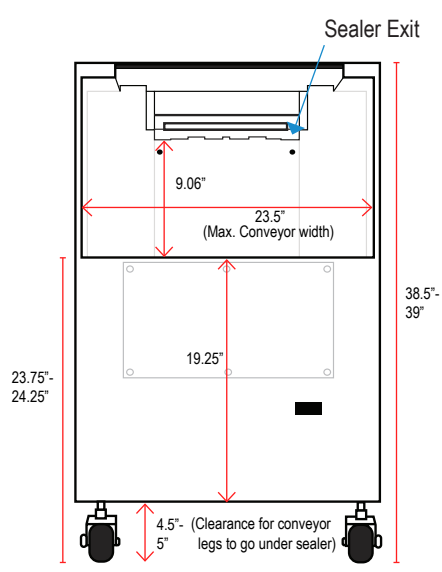

### Top view

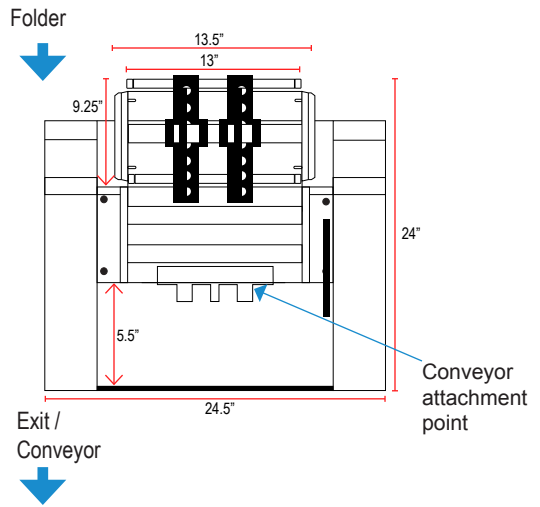

### Power supply

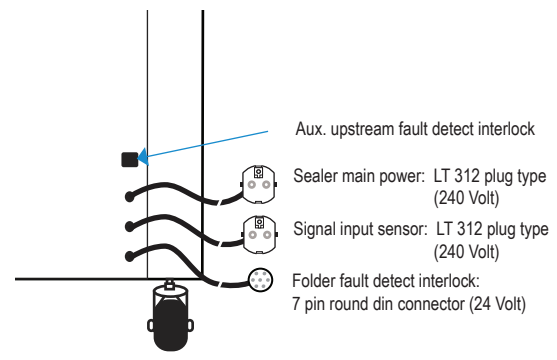

### Specifications

Speed:	Fixed speed of 40,000 forms/hour
Paper Size:	Up to 11.5" wide
Dimensions:	25" W x 24" L x 38.5" - 39" H
Weight:	180 lbs. (82kg)
Motor:	1/2 HP AC
Power:	240V, Single Phase
Power Input Connection:	240 Volts
Signal Input Connection:	240 Volts to start relay
Fault Detection Connection:	24 Volt

**WWW.WHITAKERBROTHERS.COM**  
**3 TAFT COURT**  
**ROCKVILLE, MD 20850**  
**800-243-9226**