

RemotePoint®  
**Sapphire  
Presenter**



VP4585

## Laser Safety Statement

CAUTION: Use of controls or adjustments or performance of procedures other than those specified herein may result in hazardous radiation exposure. The laser is activated by pressing the laser button identified in the user guide.

- **Do not stare into the laser beam, or shine the laser at others.**
- Do not allow minors to use the laser unsupervised.
- Avoid pointing the laser pointer at any reflective surface.
- Do not disassemble the device, it has no serviceable parts.
- Do not immerse in any liquid or expose to heat or moisture.
- Use only within the designed operating temperature range of 0-40 degrees C.

## Laser Specifications:

The laser used in the VP4585 complies as Class 2 laser product with: IEC/ EN 60825-1: 1994+A1+A2, and CFR Title 21 1040.10 and 1040.11, except for deviations pursuant to Laser Notice No. 50, dated June 24, 2007.

## System Requirements

### Hardware:

- 1 available USB port

### Operating System:

- Windows 2000, XP, Vista, 7 or 8
- Macintosh OS X (F5 Slideshow and Dark Screen not supported)

## Package Contents

- RemotePoint® Sapphire Presenter
- USB receiver dongle (stored inside Presenter)
- 2 x AAA batteries
- User guide
- Zippered carrying case

## Step 1

### Install the Batteries (Supplied)

- Open the battery compartment by pressing down the cover latch and sliding the door off the Presenter.
- Insert the two supplied AAA batteries to the battery slots.
- Make sure the positive (+) and negative (-) ends of the batteries match the polarity markings inside the battery compartment.
- Slide the battery cover back into position.

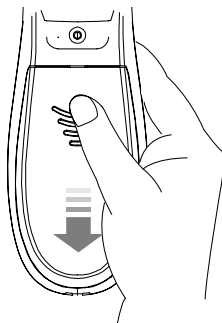

*Slide the battery cover off*

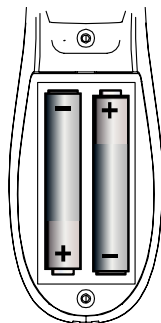

*Insert the batteries*

## Step 2

### Plug In the Receiver

- Retrieve the USB receiver dongle from the built-in storage bay on the Presenter.
- Connect the USB receiver dongle to an available USB port on your computer. Wait for the computer to go through its default process of recognizing the new hardware and installing the built-in native driver.
- Power on the Presenter by sliding the On/Off switch to the On position.
- The Presenter and the receiver dongle come pre-paired at the factory. The Presenter should be functioning at this point.

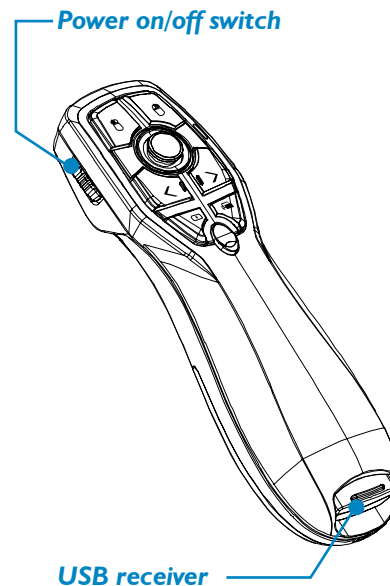

# Step 3

## Use the Presenter

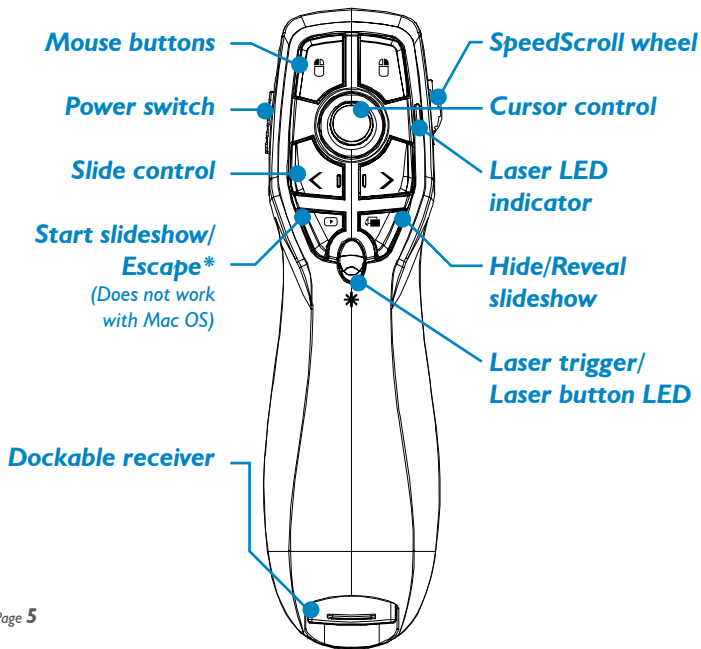

## LED Indicators

Laser Button LED	Description
Red LED on for 3 Seconds	Power is on

LED Indicator	Description
Blinking Red LED	Battery low
Solid Green LED	Laser beam active
Blinking Green / Red LED	Pairing
Red LED on for 3 Seconds	Pairing is successful

## Re-Pairing the Receiver if Needed

- If for any reason the Presenter does not function properly (i.e. the presentation slides do not advance to the next page), there may be other wireless devices in the vicinity operating in the same radio frequency channel. To reset it to another channel, bring the Presenter close to the receiver dongle on the computer, press down on the “Start slideshow/Escape” and the “Hide/Reveal slideshow” buttons on the Presenter simultaneously for about 5 seconds. This step can be repeated when needed.

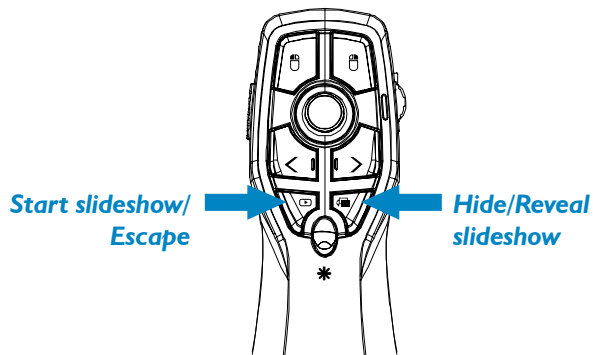

**Pairing the remote to the dongle**

## Warranty

SMK-Link Electronics Corporation (SMK-Link) warrants to the original end-user purchaser of the Product (“you”) that the Product, excluding batteries, will be free from defects in materials and workmanship under normal use and service for one-year from date of purchase. If the Product becomes defective in materials or workmanship during the warranty period, SMK-Link will, at its option, either repair or replace it. The replacement unit may be a more current or upgraded model if the originally purchased model is not available. Any Product repaired or replaced under the terms of the warranty is covered for the remainder of the original warranty period or ninety (90) days from the date of return shipment, whichever is longer. This warranty does not cover Products which have been subjected to misuse, accident, physical damage, improper installation, abnormal operation or handling, neglect, inundation or fire or when Product regulatory label has been removed, altered or rendered illegible; nor does it cover accessory or consumable items.

SMK-Link shall not be liable for any indirect special, incidental, or consequential damages. SMK-Link’s total liability for damages for any cause related to, or arising out of, the use or inability to use the Product shall not exceed the original price paid for the Product even if SMK-Link has been informed of such possibility.

If your Product requires service under warranty, you must first contact SMK-Link product support to receive an RMA number. Shipping of defective units back to SMK-Link is at your expense. The contact information can be found on the SMK-Link website: [www.smklink.com](http://www.smklink.com).

The warranty does not affect your statutory rights and you may have other

rights which vary from state to state and country to country. This warranty is understood to be the complete and exclusive agreement between the parties, superseding all prior agreements, oral or written, and all other communications between the parties relating to the matter of this warranty.

The above warranty does not apply to Products sold in Australia. Products sold in Australia by an authorized reseller will contain an Australia specific warranty statement.

## Regulatory Compliance

### FCC Certification

This device complies with Part 15 of the FCC Rules. Operation is subject to the following two conditions: (1) This device may not cause harmful interference, and (2) This device must accept any interference received, including interference that may cause undesired operation.

This equipment has been tested and found to comply with the limits for a CLASS B digital device, pursuant to Part 15 of the FCC rules. These limits are designed to provide reasonable protection against harmful interference when the equipment is operated in a residential installation. This equipment generates, uses, and can radiate radio frequency energy. If not installed correctly and used in accordance with the instruction guide, it may cause harmful interference to radio communications. However, there is no guarantee that this radio interference will not occur in a particular installation. If this equipment does cause harmful interference to radio or television reception,

which can be determined by turning the equipment on and off, the user is encouraged to try to correct the interference by one or more of the following measures:

- Re-orient or relocate the receiving antenna.
- Increase the separation between the equipment and the receiver.
- Connect the equipment into an outlet on a circuit different from that to which the receiver is connected.
- Consult the dealer or an experienced Radio-TV technician for help.

**Notice: Any changes or modifications not expressly approved by the party responsible for compliance could void the user's authority to operate the equipment. Extension cables are not recommended, if used, they must be shielded in order to comply with the emission limits. This device and its antenna(s) must not be co-located or operating in conjunction with any other antenna or transmitter.**

## IC Certification

The term "IC" before the certification/registration number only signifies that the Industry Canada technical specifications were met.

## Declaration of Conformity

Manufacturer:

SMK-Link Electronics Corporation  
3601-B Calle Tecate  
Camarillo, CA 93012

Hereby, SMK-Link declares that the VP4585 is in compliance with the essential requirements and other relevant provisions of Directive 1999/5/EC.

EMC/EMI/Safety Standards

EN 300 440-2 V1.1.1 (2001-09)  
EN 301 489-1 V1.4.1 (2002-08)  
EN 301 489-3 V1.4.1 (2002-08)  
EN 60825-1 (1994, A11:1996, A2:2001)

## Thank You

Congratulations on your purchase of the RemotePoint Sapphire Presenter. We thank you for choosing SMK-Link Electronics to meet your wireless needs and look forward to serving you in the future. To learn about new SMK-Link products as they become available, and to ensure the best possible customer support, please register your product online at [www.smklink.com/register](http://www.smklink.com/register).

## Support

SMK-Link Electronics Corporation  
3601-B Calle Tecate  
Camarillo, CA 93012

TEL: (888) 696-3500  
FAX: (805) 987-6665  
Email: [pcsupport@smkusa.com](mailto:pcsupport@smkusa.com)

[www.smklink.com](http://www.smklink.com)





