

4+

# G.I. JOE

A REAL AMERICAN HERO

## COMBAT JET: SKYSTRIKER XP-14F INSTRUCTIONS

**WARNING:**  
CHOKING HAZARD—Small parts.  
Not for children under 3 years.

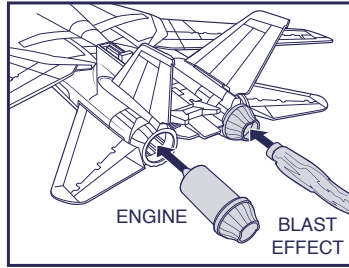
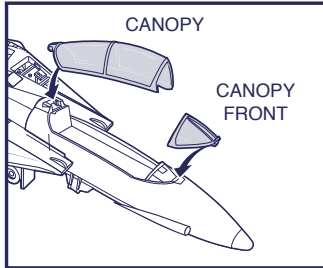

ENGINE DOORS

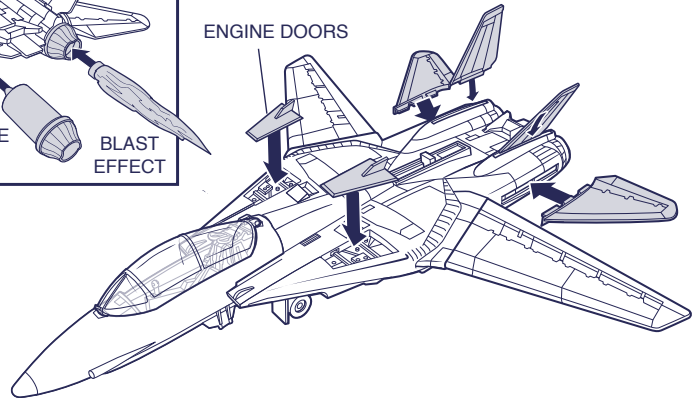
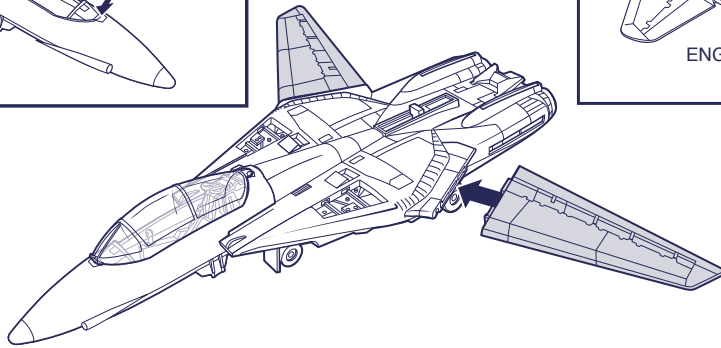

- 1** Insert the tab of the **canopy front** into the slot at the front of the cockpit. Fit the tab at the back of the **canopy** into the slot of the canopy hinge. Gently slide back until tab snaps into place. Press canopy down in front. Insert the tabs of the right and left wings into the wing slots of the fuselage.

- 2** Slide the two **engines** into the engine openings in the fuselage. Insert **blast effects** into back of engines if desired. Place the two tabs of **engine doors** into the slots above the engine detail. Snap engine doors down. They open and close easily. Using a rocking motion, insert the tabs of the tail fins into the slots in the rear of jet.

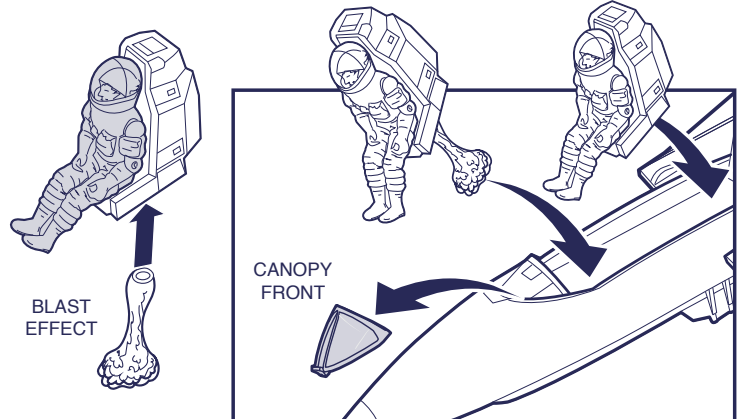
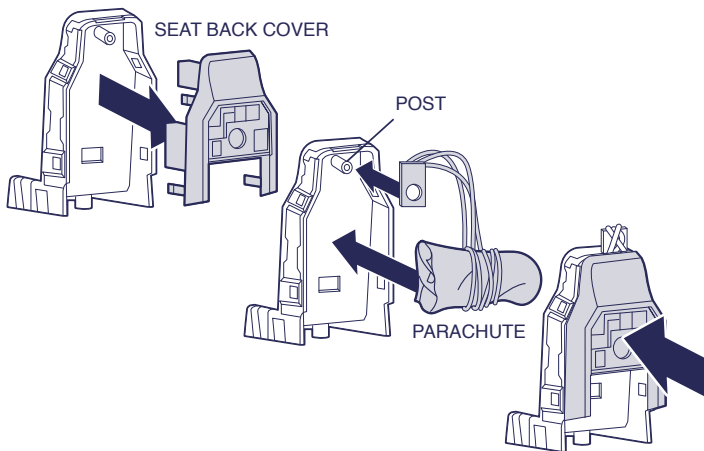

- 3** Remove the **seat back cover** from the seat. Remove the elastic from the parachute and unfold it. Slide the loop at the end of the **parachute** strings onto the **post** inside the seat back with the strings and chute pointing up. Now carefully fold the parachute lengthwise tightly and wrap the strings around it. Fit the parachute behind the seat. Reattach the seat back cover to hold the parachute in place.

- 4** Fit the hole in ACE's back over the post in the seat. Place the seat in the cockpit by fitting the peg on the bottom of the seat into the hole on the cockpit floor and press seat down. Repeat for the other seat using FAIL-SAFE or another G.I. Joe figure (sold separately). Attach the **blast effect** to cockpit and bottom of seat if desired to simulate an ejection seat pose.

- 5** When G.I. Joe is ready to "eject," remove the seat from the cockpit. Remove the seat back cover. Unwind and unfold the parachute, leaving the loop at the end of the strings attached to the post inside the seat back. Reattach the seat back cover. Hold the parachute next to the seat and throw them high into the air. G.I. Joe will parachute to safety!

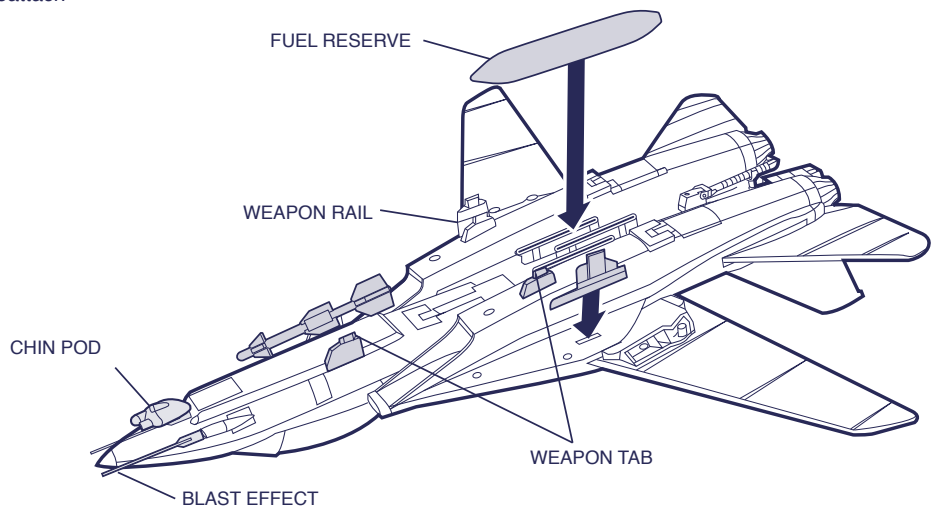
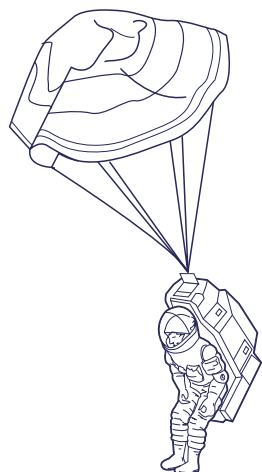

- 6** Insert **chin pod** below nose cone. Insert **weapon rail** and slide forward to lock into place. Attach missiles, bombs and **fuel reserve** accessories over the **weapon tabs** located under the jet.

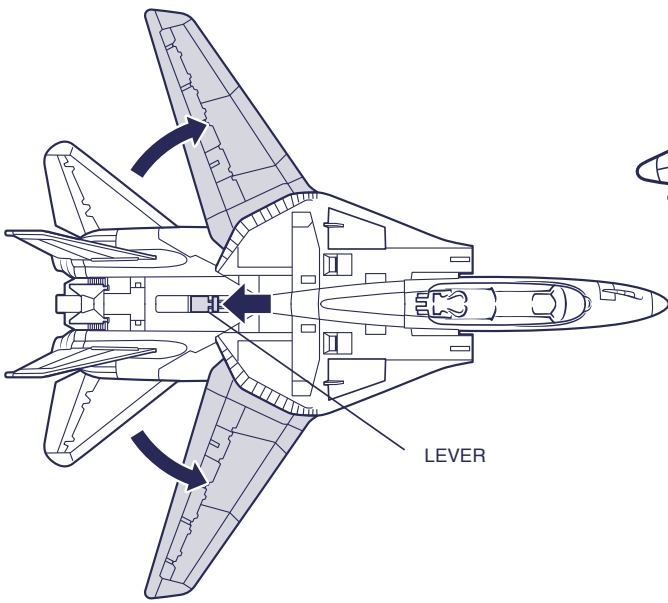

**7** To sweep the wings out, slide the control **lever** toward the rear of the jet. To sweep the wings in, slide the lever forward. You can also sweep the wings in and out using your hands.

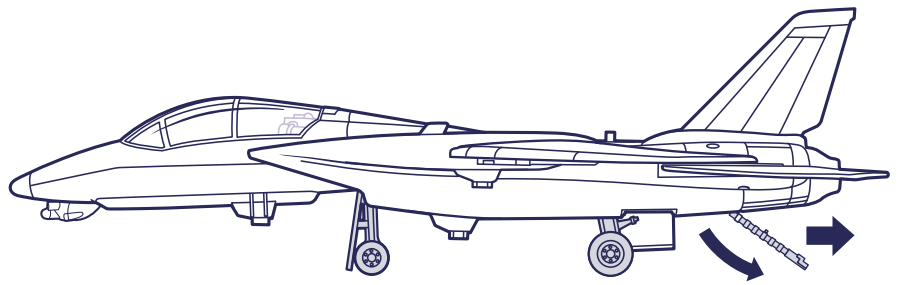

**8** To lower the landing gear unclip **tail hook** and slide the **tail hook control lever** back. To retract the landing gear wheels slide the tail hook control lever forward and insert tail hook into **clips** to hold it in place.

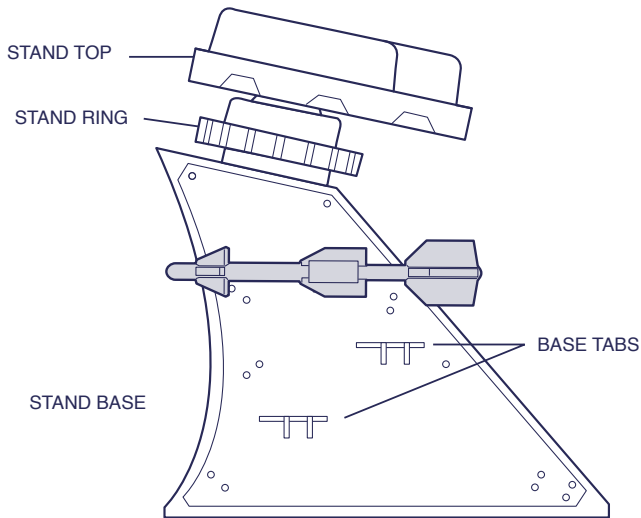
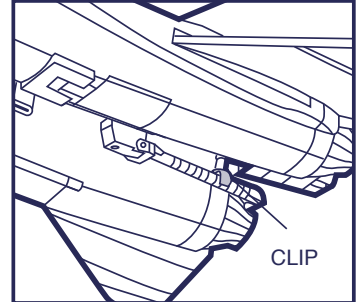

**9** Place **stand top** onto **stand ring** and then pop both onto top of **stand base**. Loosen or tighten the stand ring to adjust or set the angle of the stand top. Insert tabs on stand top into slots on belly of Skystriker to attach jet to stand. Store missile accessories on stand missile **base tabs**. Store blast effects and extra missiles in the back of stand base.

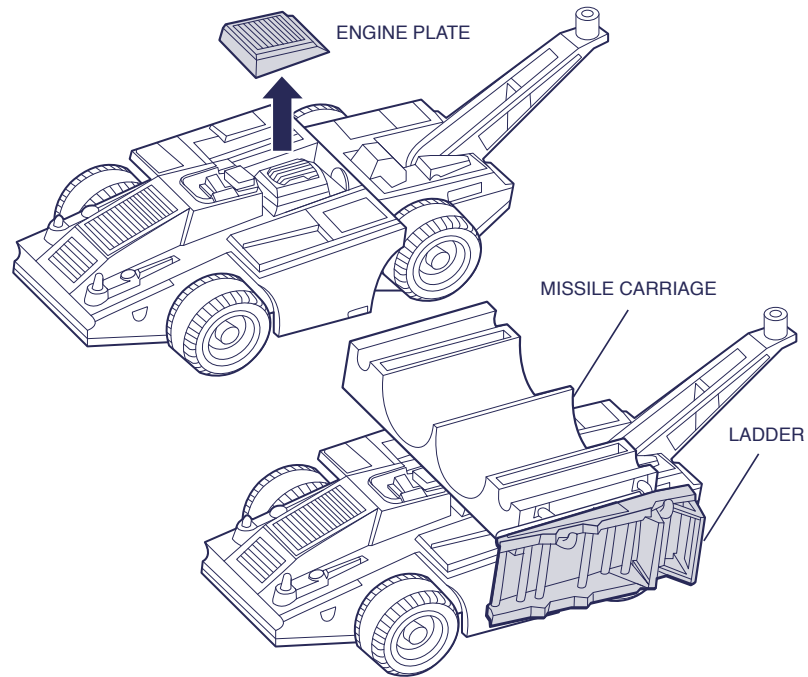

**10** Remove **engine plate** and attach **missile carriage** in its place to carry **ladder**, missile and bomb accessories.

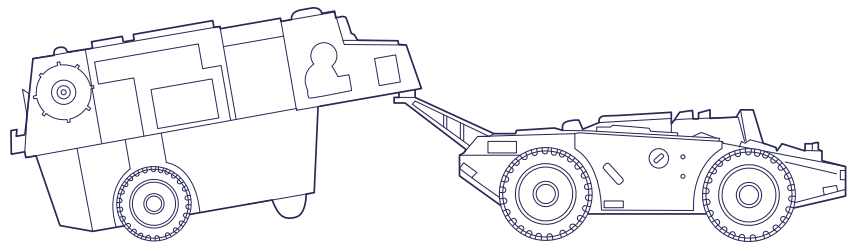
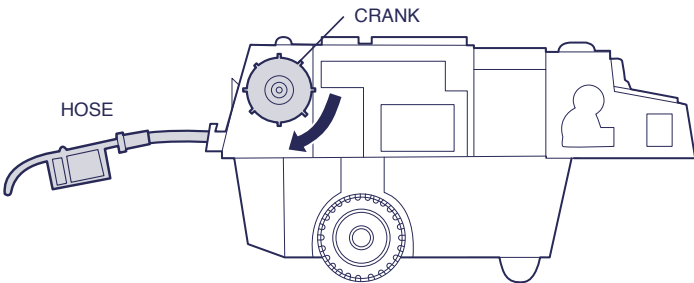

**11** Pull **hose** to extend fuel line. Turn **crank** to retract. Attach tow hitch of artillery cart to fuel cart.

Peel labels from label sheet and apply as shown to make Skystriker as accurate to the original as possible. Apply additional labels to make Skystriker resemble an authentic F-14 Tomcat or other provided labels as desired to personalize your Skystriker fleet.

**WARNING:**  
CHOKING HAZARD—Small parts.  
Not for children under 3 years.

**4+**

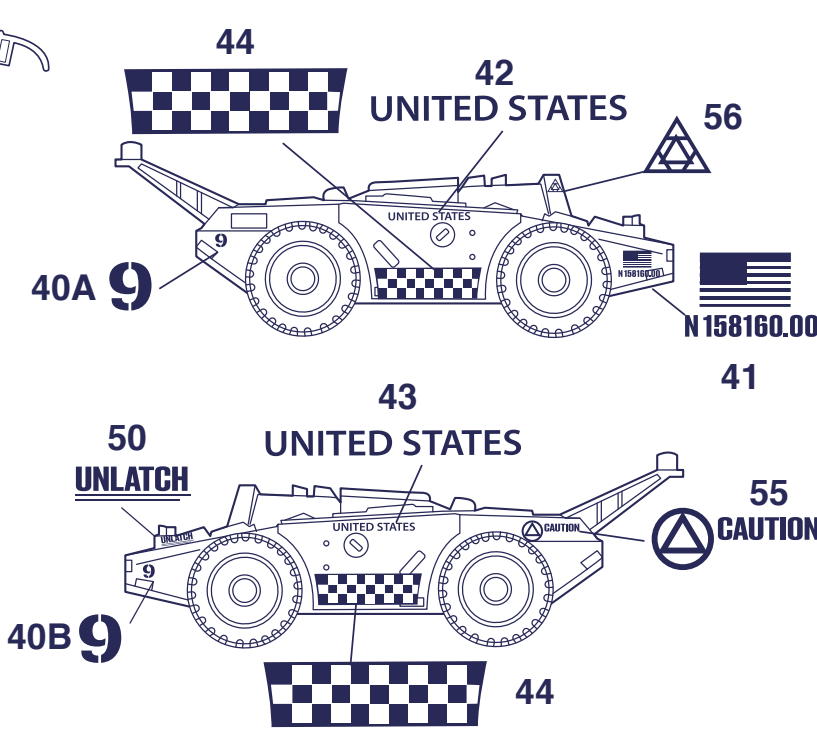
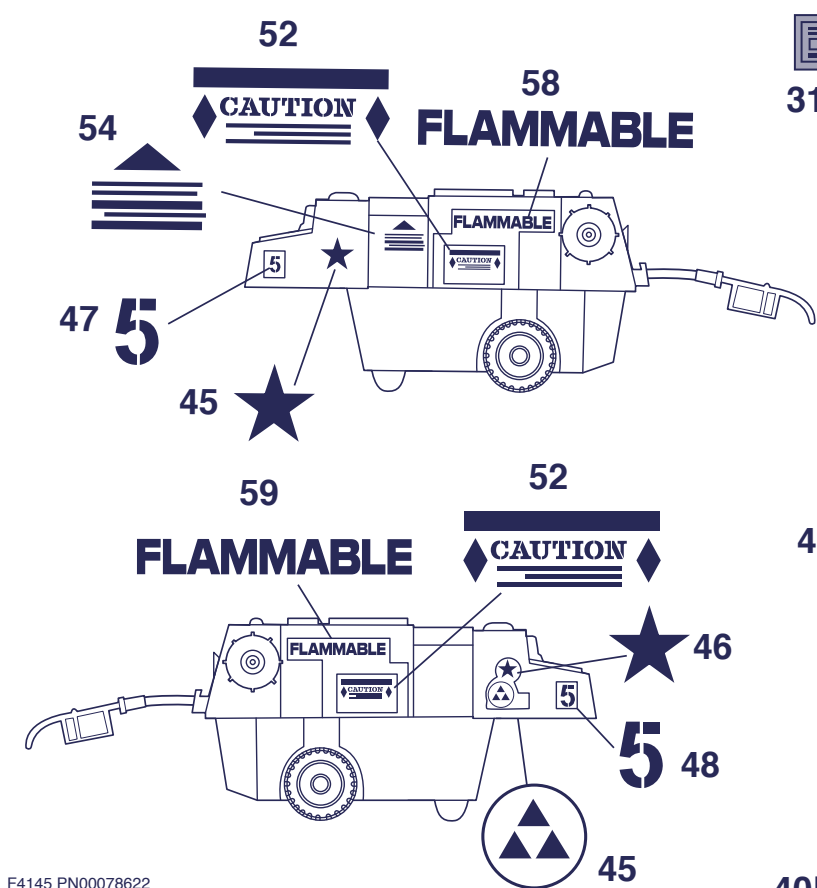
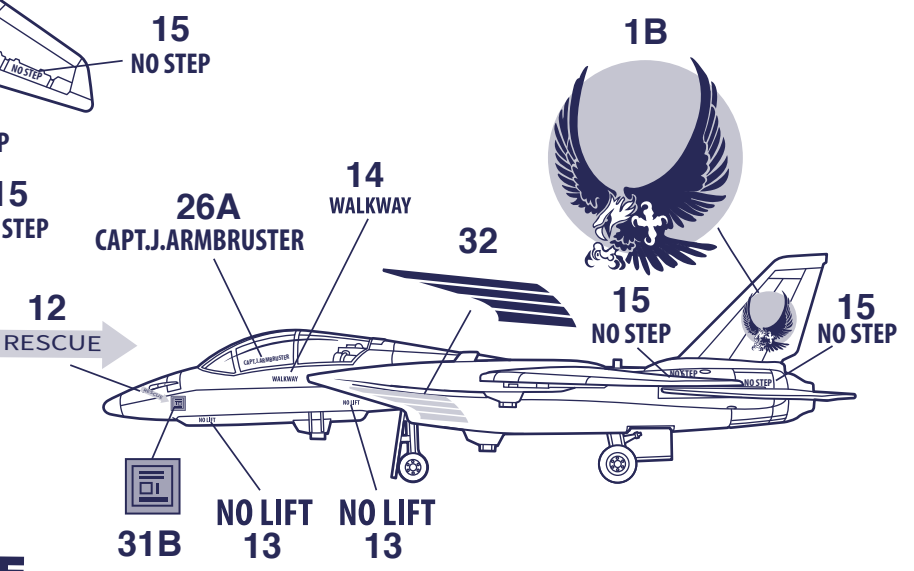
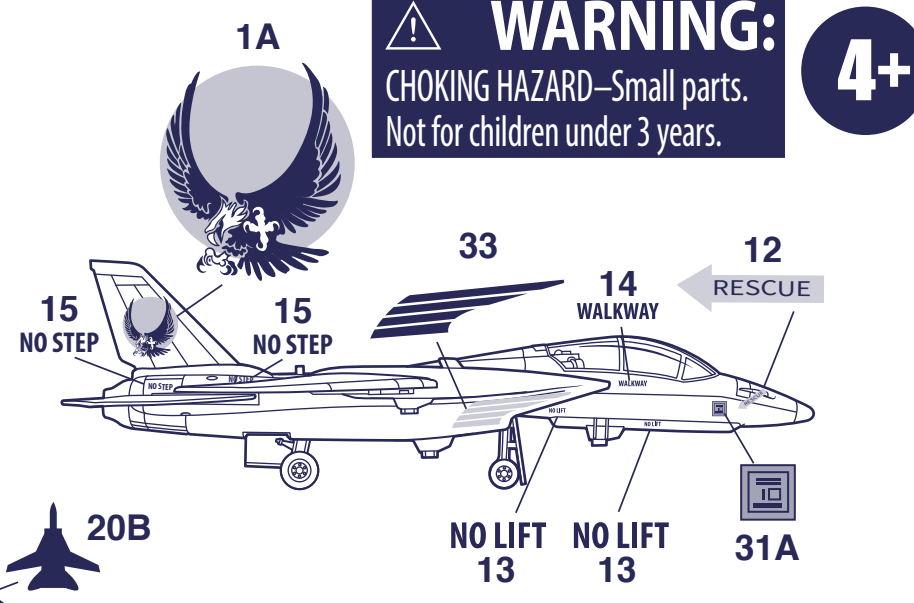
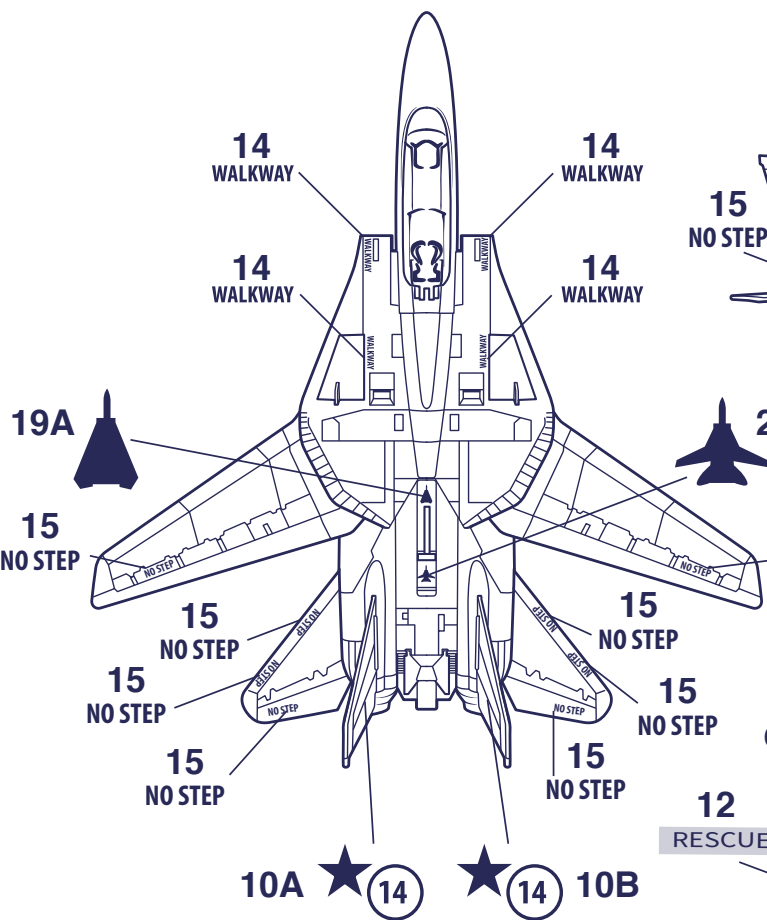

F4145 PN00078622  
F-14 Tomcat is a trademark of Northrop Grumman Systems Corporation and is used under license by Hasbro Inc.  
G.I. JOE and HASBRO and all related trademarks and logos are trademarks of Hasbro, Inc. © 2023 Hasbro.  
Hasbro, Pawtucket, RI 02861-1059 USA. HASBRO CANADA, LONGUEUIL, QC, CANADA J4G 1G2. US/CANADA TEL.  
Represented by: Hasbro, De Entree 240, 1101 EE Amsterdam, NL. © Hasbro UK Ltd.,  
P.O. Box 43, Newport, NP19 4YH, UK. Tel.: 00800 22427276. consumer\_affairs@hasbro.co.uk



## COMBAT JET SKYSTRIKER (XP-14F)

- 1) TWIN VERTICAL STABILIZERS
- 2) VARIABLE SCHEDULING – RAMP AIR INTAKE
- 3) RESERVE EXTERNAL FUEL TANK
- 4) RETRACTABLE NOSE GEAR/MAIN GEAR
- 5) NOSE MOUNTED PULSE DOPPLER RADAR
- 6) STARBOARD SIDE CYCLONE 20 MM ROTARY CANNON
- 7) CHIN POD WITH INFRA RED SENSOR & TACTICAL CAMERA SYSTEM
- 8) NON-REFLECTIVE PANEL
- 9) 360° VISIBILITY COCKPIT CANOPY
- 10) EJECTION SEATS
- 11) EVAPORATIVE FUEL LINE VENTS
- 12) MAIN FLUIDIC-COUPLING ACCESS PANELS
- 13) VARIABLE SWEEP WINGS
- 14) HORIZONTAL STABILIZERS
- 15) REMOVABLE EXHAUST NOZZLES/AFTERBURNER
- 16) GULL GRAY CAMOUFLAGE
- 17) HIGH STRENGTH TITANIUM/BORON EPOXY COMPOSITE SKIN
- 18) SITE-5 CREEPER SHORT-RANGE AIR INTERCEPT MISSILES
- 19) SITE-3 STARLING MEDIUM-RANGE AIR INTERCEPT MISSILES
- 20) SITE-3Z MERLIN LONG RANGE AIR INTERCEPT MISSILES
- 21) SIDE PANELS

