



Elastomer Expansion Joints

Part Number	Size	Std Pk	Mstr Ctn	Prod Code
-------------	------	--------	----------	-----------

Elastomer Expansion Joint - PVC (continued)

PVC with Neoprene Bellows SR Fipt - Stainless Steel Collar

EJ01-012SR	1-1/4	15	0	085
EJ01-015SR	1-1/2	10	0	085
EJ01-020SR	2	8	0	085
EJ01-025SR	2-1/2	4	0	085
EJ01-030SR	3	2	0	085

Elastomer Expansion Joint - PVC

PVC with EPDM Bellows SR Fipt - Stainless Steel Collar

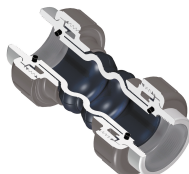

150 psi Maximum Internal Pressure Rating @ 73°F (23°C)

EJ21-007SR	3/4	10	0	085
EJ21-010SR	1	10	0	085
EJ21-012SR	1-1/4	15	0	085
EJ21-015SR	1-1/2	10	0	085
EJ21-020SR	2	8	0	085
EJ21-025SR	2-1/2	4	0	085
EJ21-030SR	3	2	0	085

Elastomer Expansion Joint - CPVC

CPVC with EPDM Bellows Socket

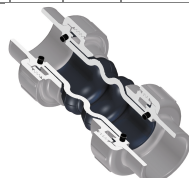

150 psi Maximum Internal Pressure Rating @ 73°F (23°C)

EJ22-007C	3/4	10	0	085
EJ22-010C	1	10	0	085
EJ22-012C	1-1/4	15	0	085
EJ22-015C	1-1/2	10	0	085
EJ22-020C	2	8	0	085
EJ22-025C	2-1/2	4	0	085
EJ22-030C	3	2	0	085

Elastomer Expansion Joint - CPVC

CPVC with EPDM Bellows SR Fipt - Stainless Steel Collar

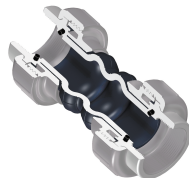

150 psi Maximum Internal Pressure Rating @ 73°F (23°C)

EJ21-007CSR	3/4	10	0	085
EJ21-010CSR	1	10	0	085
EJ21-012CSR	1-1/4	15	0	085
EJ21-015CSR	1-1/2	10	0	085
EJ21-020CSR	2	8	0	085
EJ21-025CSR	2-1/2	4	0	085
EJ21-030CSR	3	2	0	085

Repair Couplings

(S119) Socket x Socket

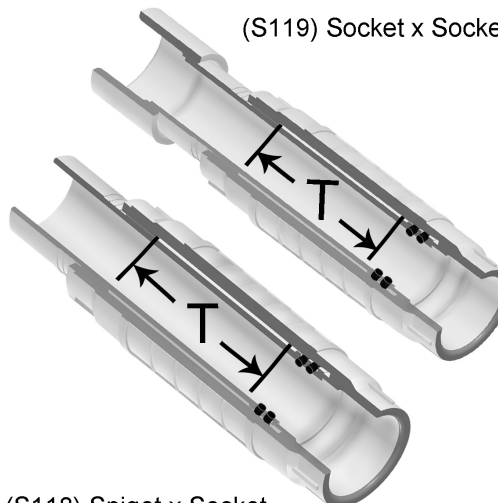

(S118) Spigot x Socket

- Multi-function Telescoping Design
- Regular and Short configurations
- Socket x Socket Configuration for Pipe Repair or Use as a Short-Stroke Expansion Joint
- Spigot x Socket Configuration for Replacing Damaged Fittings
- Both Configurations can be Easily Modified for Opposite Use
- Double O-ring Seal in EPDM or high-grade FKM
- 1/2" - 2" Pressure Rated to 235 PSI @ 73°F (23°C)
- 2-1/2" - 4" Pressure Rated to 200 PSI @ 73°F (23°C)
- 6" Pressure Rated to 150 PSI @ 73°F (23°C)
- NSF® Certified for Potable Water Use

Part Number	Size	Travel - T	Std Pk	Mstr Ctn	Prod Code
-------------	------	------------	--------	----------	-----------

Repair Coupling - Spigot x Socket

PVC White with EPDM O-ring

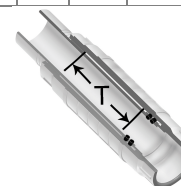

Can be used as short-stroke Expansion Joint

S118-05	1/2	2-7/8	25	0	025
S118-07	3/4	4	30	0	025
S118-10	1	4-1/16	15	0	025



Expansion Joints Product Repair Couplings & Short Repair Couplings

Repair Couplings

Part Number	Size	Travel - T	Std Pk	Mstr Ctn	Prod Code
-------------	------	------------	--------	----------	-----------

Repair Coupling - Spigot x Socket (continued)

PVC White with EPDM O-ring

S118-12	1-1/4	4-1/16	25	0	025
S118-15	1-1/2	3-13/16	25	0	025
S118-20	2	4-5/16	12	0	025
S118-25	2-1/2	5-9/16	5	0	025
S118-30	3	5-9/16	4	0	025
S118-40	4	6-3/16	2	0	025
S118-60	6	6-5/8	1	0	025

**Unit Must Be Thrust Blocked
T = Repair Coupling Travel**



Repair Coupling - Socket x Socket

PVC White with EPDM O-ring

Can be used as short-stroke Expansion Joint

S119-05	1/2	2-7/8	30	0	025
S119-07	3/4	4	24	0	025
S119-10	1	4-1/16	20	0	025
S119-12	1-1/4	4-1/16	10	0	025
S119-15	1-1/2	3-13/16	16	0	025
S119-20	2	4-5/16	10	0	025
S119-25	2-1/2	5-9/16	5	0	025
S119-30	3	5-9/16	4	0	025
S119-40	4	6-3/16	2	0	025
S119-60	6	6-5/8	1	0	025

**Unit Must Be Thrust Blocked
T = Repair Coupling Travel**

Short Repair Couplings

Space Saving, Compact Version of Standard Repair Coupling
Requires 1/3 less Space

Repair Coupling - Short, Spigot x Socket

PVC White with EPDM O-ring

SH118-05	1/2	1-15/16	36	0	025
SH118-07	3/4	2-3/16	30	0	025
SH118-10	1	2	35	0	025
SH118-12	1-1/4	2-1/2	25	0	025
SH118-15	1-1/2	2-1/2	32	0	025
SH118-20	2	3	15	0	025

**Unit Must Be Thrust Blocked
T = Repair Coupling Travel**



Part Number	Size	Travel - T	Std Pk	Mstr Ctn	Prod Code
-------------	------	------------	--------	----------	-----------

Repair Coupling - Short, Socket x Socket

PVC White with EPDM O-ring

SH119-05	1/2	1-15/16	40	0	025
SH119-07	3/4	2-3/16	30	0	025
SH119-10	1	2	30	0	025
SH119-12	1-1/4	2-1/2	20	0	025
SH119-15	1-1/2	2-1/2	21	0	025
SH119-20	2	3	12	0	025

**Unit Must Be Thrust Blocked
T = Repair Coupling Travel**

