

Rough Terrain

Scissor



SR4084

Snorkel

www.snorkelusa.com

Snorkel SR4084

Platform	
Height.....	39'10" (12.1 m)
Size	6' x 10' (1.8 x 3 m)
Rollout Extension	4' (1.3 m)
Platform Length – extended.....	168" (427 cm)
Capacity	750 lbs. (340 kg)
Capacity on Rollout Extension	350 lbs. (158 kg)
Machine Dimensions	
Overall Stowed Height	105" (2.7 m)
Overall Width.....	7' (2.1 m)
Overall Length.....	149" (3.8 m)
Wheelbase	7'5 1/2" (2.3 m)
Weight.....	0,320 lbs. (4,685 kg)
Ground clearance.....	6" (15.2 cm)
Tire size/Type.....	26 x 12 (Foam filled)
Performance	
Power Source.....	Liquid cooled Gas/Diesel
Gradeability	30%
Drive Speed – Elevated	0.4 mph (0.6 km/h)
Drive Speed – Stowed	2.2 mph (3.5 km/h)
Maximum drive height.....	32' (9.75 m)
Turning radius outside	8'10" (2.7 m)
Turning radius inside.....	16'7" (5.1 m)

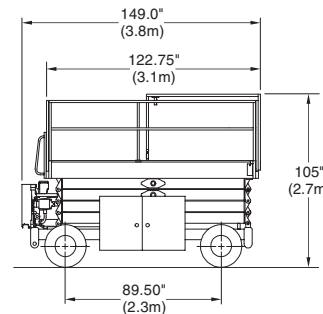
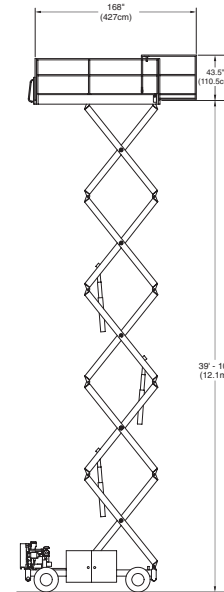

Standard Features

- Pothole Protection System
- Level Sensor
- Joystick Control on removable console
- Two wheel parking brakes
- 4' roll out extension
- Hydraulic warm-up kit
- Fully proportioned drive/lift
- 4-wheel drive system
- Drive motion alarm
- Side trays
- Foam filled tires
- Hydraulic outriggers
- 125 volt GFCI AC outlet at platform
- High engine temp and low oil pressure shut down

Options

- Horn
- Flashing Light
- Battery Condition Indicator
- Lanyard Anchors
- Key Switch
- Swing Gate
- AC Generator
- Big Paw Pneumatic tires

DANGER: Models described in this brochure are NON-INSULATED and do not provide electrocution protection from contact with or close proximity to energized conductors which is pointed out on decals and placards attached to the machine. Only qualified and trained operators are to be authorized to use and operate a work platform. Aerial work platforms must be elevated only on firm, level surface. Products in this brochure comply with applicable ANSI Standards. This literature is for illustrative purposes only. Consult Operating Maintenance and Parts Manuals for proper procedures. Specifications may vary and are subject to change without notice or obligation.

Manufacturing Plant

2009 Roseport Road
Elwood, Kansas 66024
800-255-0317
785-989-3000
785-989-3070 Fax

Australia

26 Redfern Road
Wetheril Park NSW
2164 Australia
(02) 9725 4000
(02) 9609 3057 Fax